

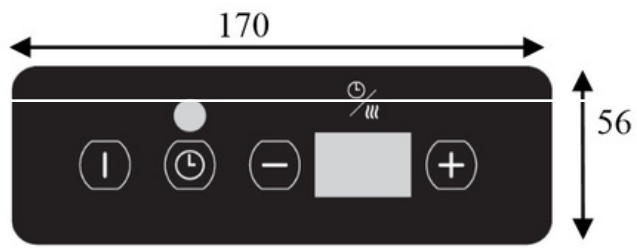

MADE IN FRANCE

Product Advantages:

- Controls can be locked (child proof).
- Glass touches, On/Off, manual temperature setting (+/-) with 4 digits display and timer control
- Stainless steel casing.
- Washable filter.
- Remote controls
- 2-year warranty parts and labour

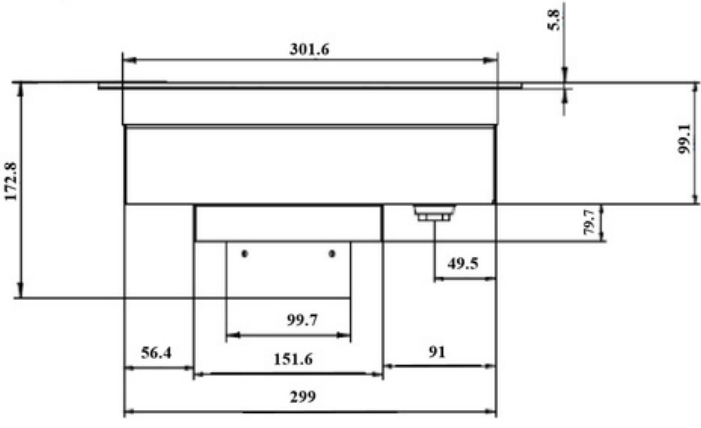
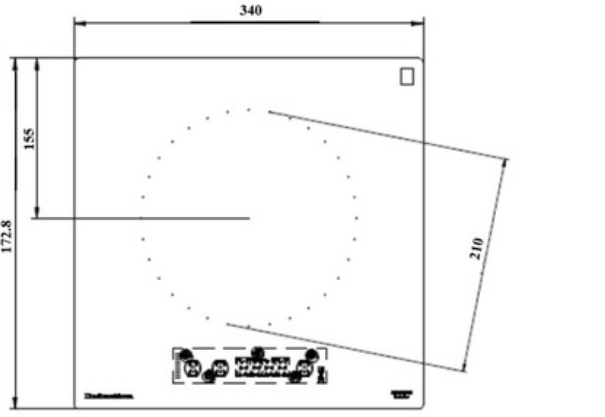

Technical Data:

Width x Depth x Height	340 x 340 x 173 mm
Installation dimensions	346 x 346 mm
Connected load (kW)	0.65
Voltage (V)	240 1 phase AC
Recommended fuses (A)	1 x 4
External Structure	AISI 304 stainless steel
Cooking surface	Vitroc ceramic top glass
Amp load	3 A
Control panel	Glass touches
Weight (net)	8 kg
Details and options	Including a power cord and a washable filter (wash regularly).

