

MADE IN FRANCE

Setting	Power (W)	Setting	Power (W)
1	25	14	1000
2	50	15	1100
3	100	16	1200
4	150	17	1300
5	200	18	1400
6	250	19	1600
7	300	20	1800
8	400	21	2000
9	500	22	2200
10	600	23	2400
11	700	24	2700
12	800	25	3000
13	900		

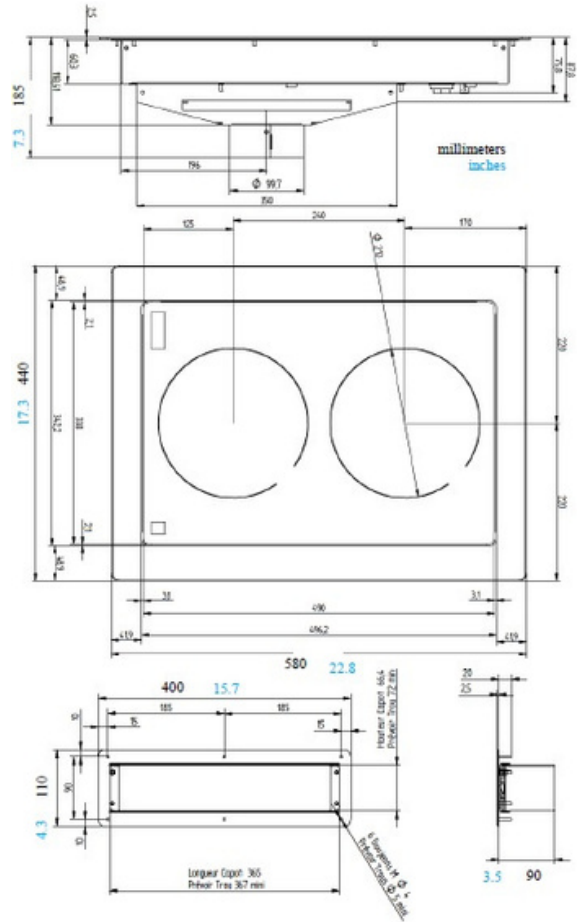

Product Advantages:

- On/Off, manual power setting (+/-) with 2 digits display for each zone, booster.



Technical Data:

Width x Depth x Height	440 x 580 x 70 mm
Built-in dimensions	410 x 550 x 70 mm
Connected load (kW)	6.0
Voltage (V)	2 x 240 1 phase AC
Recommended fuses (A)	2 x 15
External Structure	AISI 304 stainless steel
Cooking surface	Vitroc ceramic top glass
Generator coil	210 mm diameter for each zone
Control panel	Glass touches
Weight (net)	13 kg
Details and options	Including a 1m80 power cord and a filter (wash regularly).

