



PRODUCT ADVANTAGES

- Double capacity: the double wide wash chamber can cover 2 racks or bigger containers
- VISIOTRONIC control: single button control with remaining time indicator together with text and graphic display
- SENSO-ACTIVE resource management: constantly measures the quality of the wash water and keeps the amount of rinsing needed in each rinse cycle to the minimum in order to guarantee a fully hygienic wash result
- Exhaust energy storage: the fully enclosed 4-sided hood keeps steam and energy inside the system: energy saving up to 6 kW; less humidity in the kitchen area and better hygienic conditions
- CLIP-IN wash and rinse arms: wash and rinse arms can be removed with one hand and without any tools
- GENIUS-X² fine filter system: advanced filter system with pre-wash function reduces detergent consumption up to 35%
- VAPOSTOP (optional): prevents vapour escaping from the machine when the hood is opened
- Certified to remove the need for an exhaust canopy
- Intelligent energy management: the available energy is used continuously. Thus, at a low total loading value the heating time gets reduced
- Interlocked strainer: prevents operation without tank strainer
- EASY-CLEAN concept: blue markings in the machine help the operator to identify the components which require cleaning

TECHNICAL DATA

Cycle times*	60 / 90 / 180 sec. & continuous (20min)
Water consumption	2 l/rack
Tank capacity	40 litres
Tank heating	3.3 kW
Power supply	415 / 50 / 3N
Booster loading	
Standard	12.4 kW
Alternative	6.2 kW
Total loading	
Standard	16.7 3 x 32 A
Alternative	10.5 3 x 20 A
Wash pump	2 x 0.7 kW
Rack size	500 x 500 mm
Loading height	440 mm
Noise level	68 dB (A)
Weight (gross / net)	212 / 180 kg

INDUSTRY KITCHENS

www.industrykitchens.com.au 1800 611 058

*Thermostat guarantees required temperatures with cold water, the actual cycle times extend accordingly.

For corner operation we recommend to make the right side of the machine accessible for service.

For machine protection the water hardness should not exceed 3°dH, if higher we recommend using an integrated water softener or a HOBART HYDROLINE water treatment system.

DIMENSIONAL DRAWING

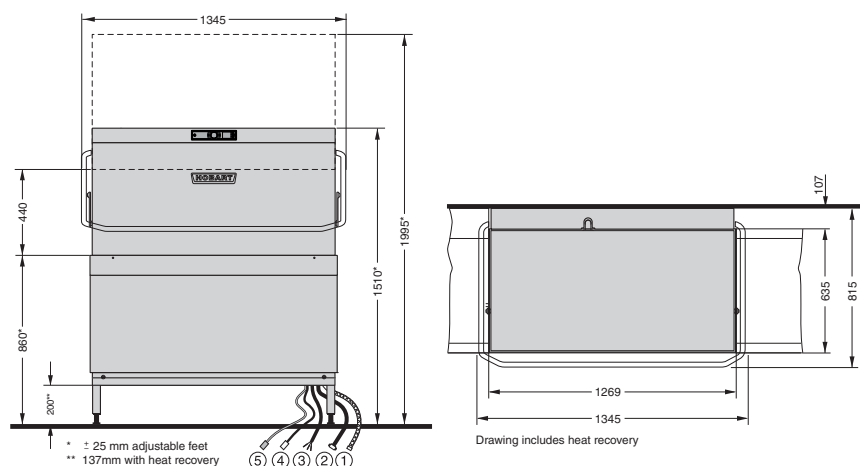

CONNECTIONS

① Drain hose	2,000 mm ID 20 / OD 25
② Supply hose	2,000 mm R 3/4"
Required flow rate	5 l/min
Flow pressure	0.5 bar - 6 bar
Max. supply water temperature	60 °C
③ Power cord	2,500 mm
Supply hose for	
④ Detergent	2,000 mm
⑤ Rinse aid	2,000 mm