

Star Line 40 Spiral Mixer

Description

Perfect for a busy pizzeria or small bakery

The design of this 2 speed spiral mixer has the bowl rim at a height of 710mm from the floor. This means there is less bending over to get the dough out of the bowl. The mixer is fully auto with 2 timers, and can be used in manual mode as well. The spiral transmission with trapezoidal belt drive is very robust compared to chain driven spiral mixers. The mixer is suitable for all types of dough, especially artisan style dough.

The distinctive features of this machine are:

- Spiral mixer with fixed bowl from 30 to 60 kg dough capacity.
- Sturdy body in painted steel.
- Fitted with one motor only.
- Two speeds on bowl and spiral tool.
- Silent bowl and spiral transmission through trapezoidal belts.
- Control panel with double scale electro-mechanical timer.
- Mobile bowl cover: stainless steel grid.
- Great dough result and extremely limited temperature increase.
- Practically maintenance-free.
- Suitable for an artisan use (1 shift per day) and for dough mixtures with an hydration greater than 55% with European flour.



Star Line 40 Spiral Mixer

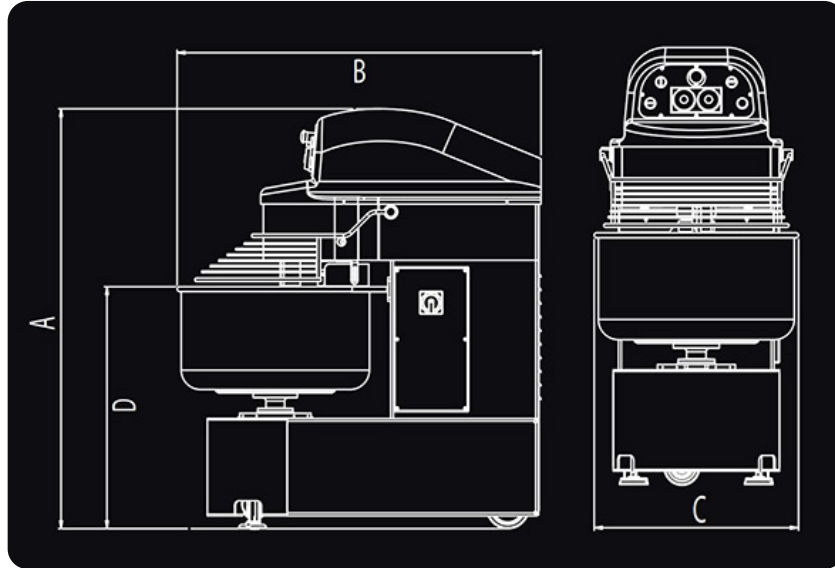

Star Line 40 Spiral Mixer – Specifications

Features	Specifications
Dough Capacity with minimum 55% water content	40 Kg
Flour Capacity	25 kg
Bowl Volume	60 lt
Motor Power	1,5 / 3 kW
Power	415V / 50Hz/ 3 phase
Height (A)	1235 mm
Depth (B)	1025 mm
Width (C)	545 mm
Floor to Bowl rim Height (D)	710 mm
Weight	235 Kg