



Electrak[®] XD – Technical Features



Standard Features

- Constant speed irrespective of load
- Tough, strong and reliable
- Electronic Monitoring Package as standard
- Low-level signal motor switching as standard
- Speed control as standard
- Loads up to 25000 N (5620 lbf)
- Speeds up to 75 mm/s (2.95 in/s)
- Strokes up to 1200 mm
- Optional onboard controls
- Optional manual brake release and override
- Optional shock load dampening feature
- Optional force feedback

General Specifications

Screw type	ball
Nut type	load lock ball nut
Manual override	optional
Anti-rotation	yes
Static load holding brake	yes
Safety features	Electrak monitoring package: current monitoring voltage monitoring temperature monitoring temperature compensation load trip point calibration internal end-of-stroke limit switches ⁽¹⁾ full stroke dynamic braking
Electrical connections Power Signal	integral screw terminals integrated housing connector
Compliance	CE, UKCA, RoHS, REACH (EU)

Optional Electronic Control Features

CANopen [®] CAN bus
SAE J1939 CAN bus
Programmable limit switches
End-of-stroke indication output
Digital position output

Optional Mechanical Features

Shock load dampening
Manual brake release/override
Variety of front and rear adapters
Alternative adapter orientation
Rear adapter with force feedback sensor

Control Option Combinations

LXX	Electrak Monitoring package + Low-Level Signal Motor Switching + Force Feedback Output
LLX	LXX + Position Feedback Output
LXP	LXX + Analog Position Output
LLP	LXX + Position Feedback Output + End-of-stroke Outputs
PLS	LXX + Position Feedback Output + Programmable End-of-stroke Limits
CNO	SAE J1939 CAN Bus Control + Open-Loop Speed Control
COO	CANopen [®] CAN Bus Control + Open-Loop Speed Control

Accessories

Signal cable and connector harness

Electrak XD – Technical Specifications

Mechanical Specifications		
Max. static load	[kN (lbf)]	see page 22
Max. dynamic load (Fx)	[kN (lbf)]	
XDxx-B055		5.5 (1236)
XDxx-B080		8.0 (1798)
XDxx-B160		16.0 (3597)
XDxx-B200		20.0 (4496)
XDxx-B250		25.0 (5620)
Speed ^{(1) (2)}	[mm/s (in/s)]	
XD24-B055		65 (2.56)
XD48-B055		75 (2.95)
XD24-B080		50 (1.97)
XD48-B080		50 (1.97)
XD24-B160		25 (0.98)
XD48-B160		25 (0.98)
XD24-B200		16 (0.63)
XD48-B200		20 (0.79)
XD24-B250		16 (0.63)
XD48-B250		16 (0.63)
Min. ordering stroke (S) length	[mm]	100
Max. ordering stroke (S) length	[mm]	
XDxx-B055(B080)		1200
XDxx-B160		1000
XDxx-B200		800
XDxx-B250		650
Ordering stroke length increments	[mm]	50
Operating temperature limits	[°C (F)]	-40 – 85 (-40 – 185)
Max. duty cycle @ 25 °C (77 °F)	[%]	
@ full load		50
@ other load		see page ??
End play, maximum	[mm (in)]	1.2 (0.047)
Restraining torque	[Nm (lbf-in)]	0
Weight of options	[kg (lbs)]	
Shock load dampening		1.16 (2.56)
Manual brake release and override		0.71 (1.56)
Protection class - static (dynamic) ³		IP67/IP69K (IP66)
Salt spray resistance	[h]	500

¹ Speed is constant and load independent from zero to max load.
² Do not use PWM voltage for speed control to avoid damaging the onboard electronics.
³ The protection class is valid only with a mating connector attached to the signal connector in the actuator housing.

Electrical Specifications		
Available input voltages	[Vdc]	24, 48
Input voltage tolerance	[Vdc]	
XD24 (24 Vdc input voltage)		18 - 32
XD48 (48 Vdc input voltage)		36 - 60
Current draw @ min. / max. load	[A]	
XD24-Bxxx		6 / 28
XD48-Bxxx		3 / 14
Power supply ring terminal size		M6
Ring terminal hole center to insulation end distance, max. (Amax)	[mm]	34.5
Signal connector type*		
Female 12 pin Amphenol Ecomate		RTS014N12S03

* Connector manufacturers designation and part number.

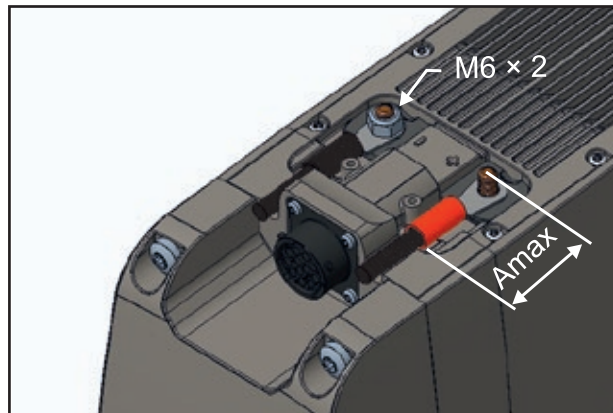

Connector for the control signals and inlets for the power supply wires.

Actuator Base Weight*

Mass	Ordering Stroke (S) [mm]																							
	100	150	200	250	300	350	400	450	500	550	600	650	700	750	800	850	900	950	1000	1050	1100	1150	1200	
[kg]	11.9	12.4	12.9	13.5	14.0	14.5	15.0	15.6	16.1	16.6	17.1	17.7	18.2	18.7	19.2	19.8	20.3	20.8	21.3	21.9	22.4	22.9	23.4	
[lbs]	26.1	27.3	28.5	29.7	30.8	32.0	33.1	34.3	35.4	36.6	37.8	39.0	40.1	41.3	42.4	43.6	44.7	45.9	47.0	48.2	49.4	50.6	51.7	

* For weight of options, see table above.



Electrak® XD – Dimensions

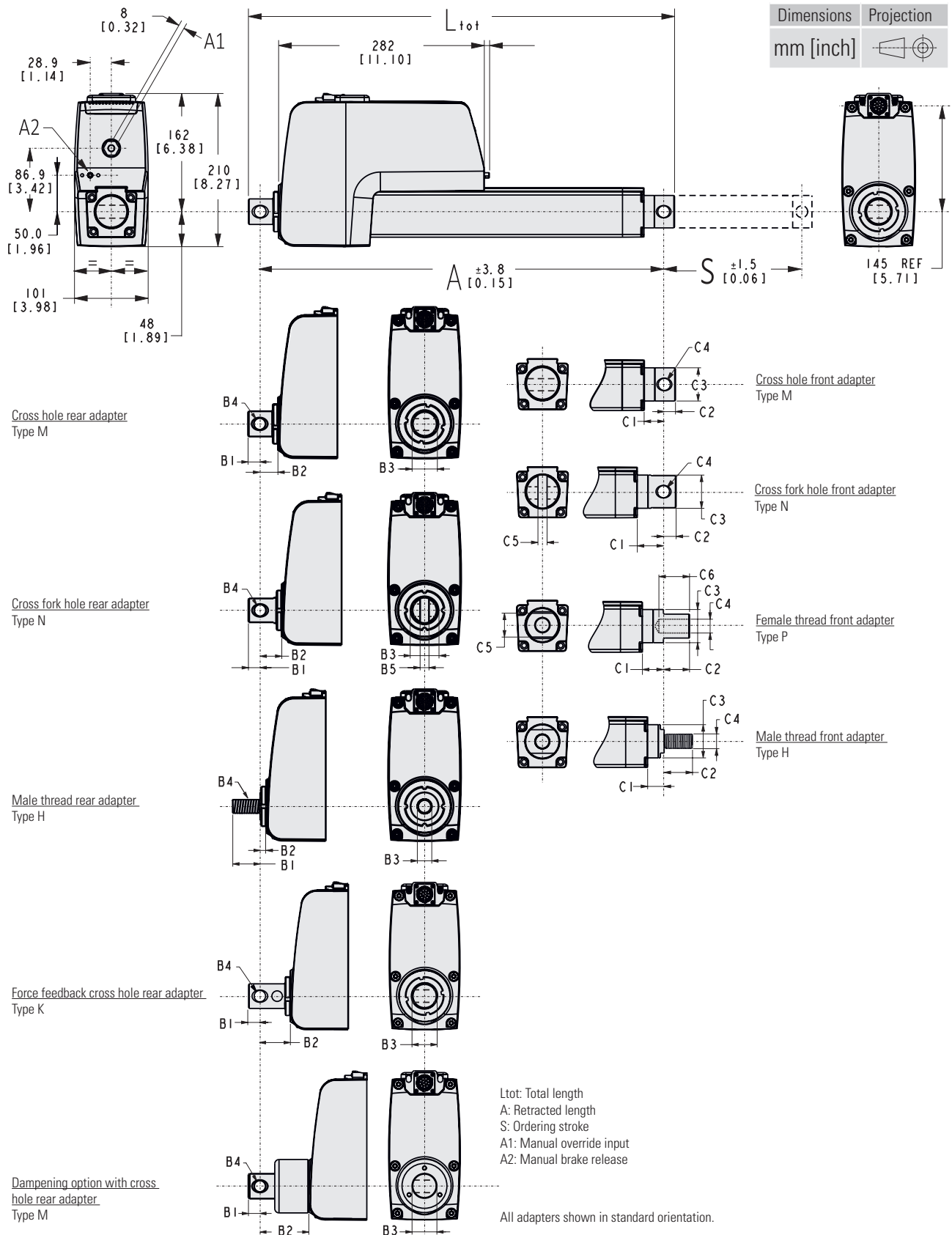

Stroke, Retracted Length and Total Length Relationships

Ordering stroke (S)	[mm]	100 - 1200 mm in 50 mm increments
Retracted Length (A)	[mm (in)]	$S + 200.8 (7.91) + B2 + C1$
Total Length (Ltot)		$A + B1 + C2$

Rear and Front Adapter Dimensions [mm (in)]

	Rear Adapter Types				
	M	N	H	K	M + dampening option
B1	16.1 (0.63)	16.1 (0.63)	38.0 (1.50)	16.1 (0.63)	16.1 (0.63)
B2	25.3 (1.00)	29.9 (1.18)	8.2 (0.32)	43.3 (1.70)	68.9 (2.71)
B3	35.0 (1.38)	35.0 (1.38)	M20 × 1.5	35.0 (1.38)	35.0 (1.38)
B4	16.2 (0.64)	16.2 (0.64)	M20 × 1.5	16.2 (0.64)	16.2 (0.64)
B5	-	12.2 (0.48)	-	--	
	Front Adapter Types				
	M	N	P	H	
C1	27.1 (1.07)	35.1 (1.38)	28.1 (1.11)	22.1 (0.87)	
C2	14.9 (0.59)	16.9 (0.67)	35.0 (1.38)	38.0 (1.50)	
C3	44.5 (1.75)	44.5 (1.75)	44.5 (1.75)	44.5 (1.75)	
C4	16.2 (0.64)	16.2 (0.64)	M20 × 1.5	M20 × 1.5	
C5	-	12.2 (0.48)	32.0 (1.26)	-	
C6	-	-	35.0 (1.38)	-	



Electrak® XD – Performance Diagrams

Load vs. Current ⁽¹⁾

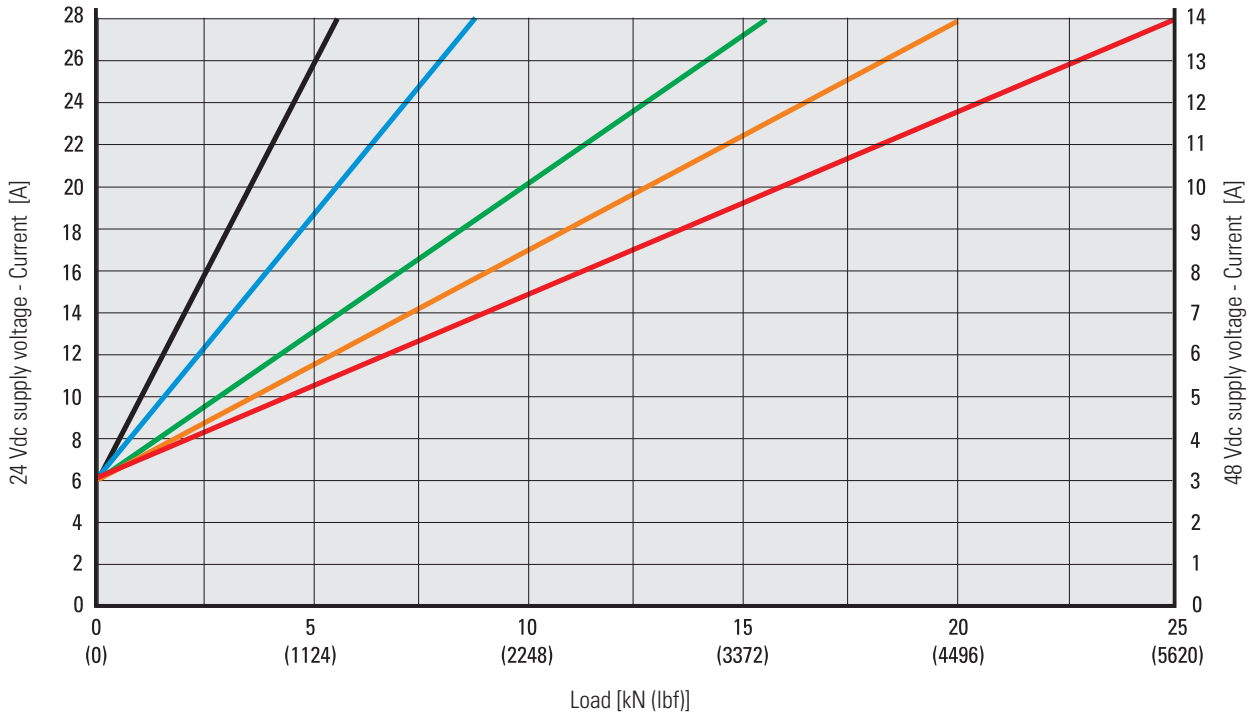

Dynamic Load vs. Stroke ⁽²⁾

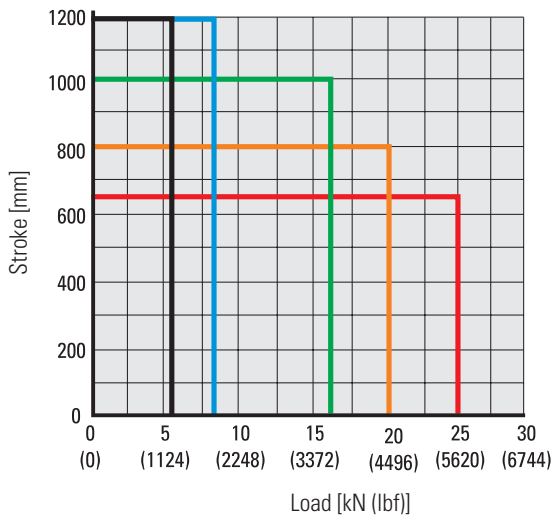

Static Compression Load vs. Stroke ⁽³⁾

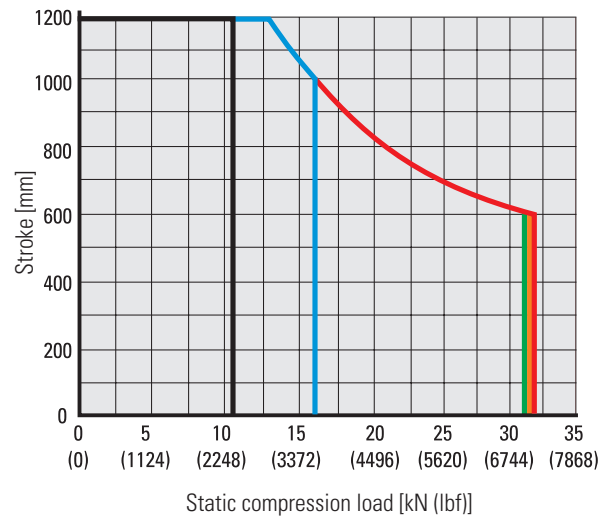

Actuator Dynamic Load Capacity Rating



(1) Curves were generated at an ambient temperature of 25°C (77°F).

(2) Curves are for both tension and compression loads.

(3) Curves are for compression loads only except for 5.5 kN, which are also valid for tension loads. Contact customer support for non-compression type loads.

Load vs. Speed

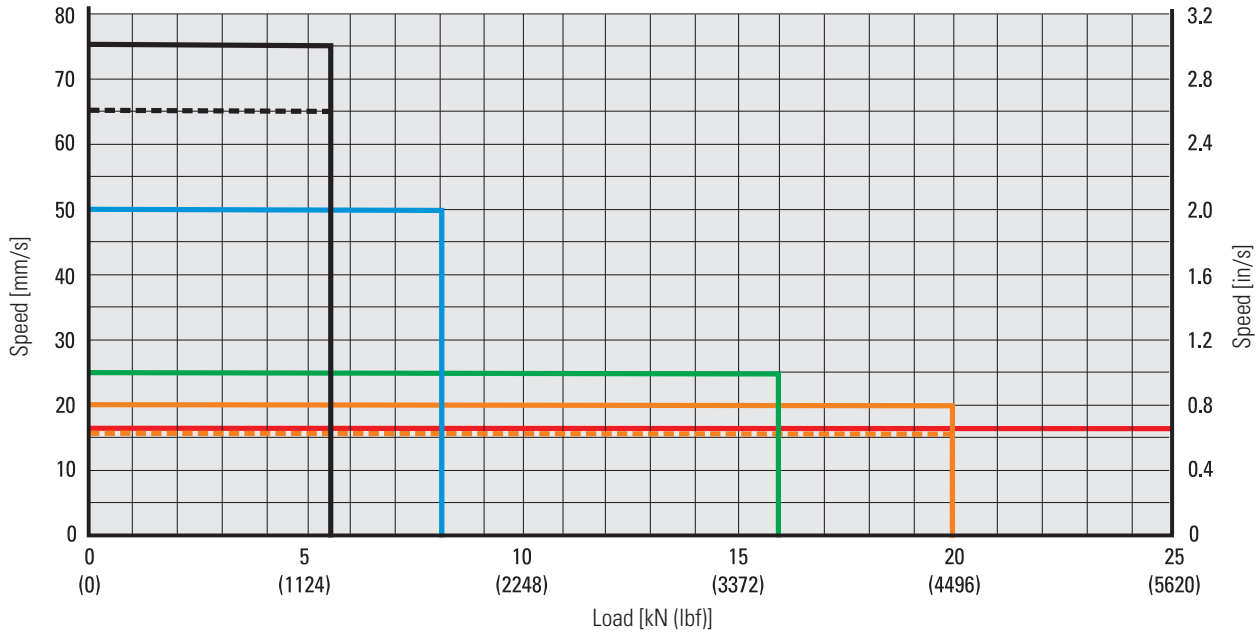

Actuator Dynamic Load Capacity Rating and Supply Voltage

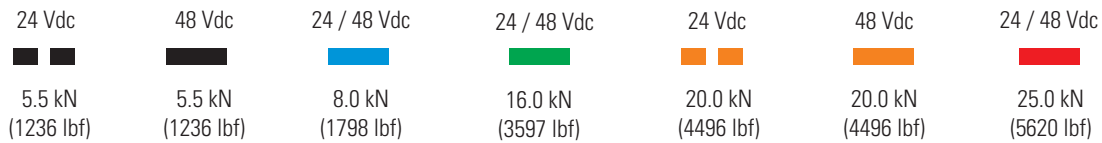

Estimated Life vs. Load

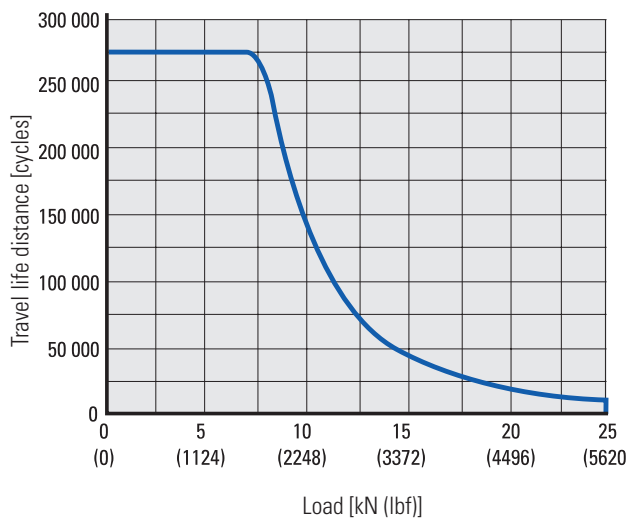

Duty Cycle

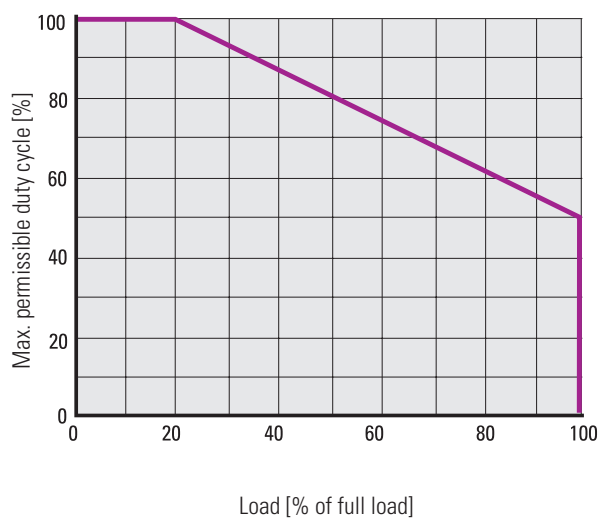

Estimation for a fully loaded unit with 300 mm stroke moving a resistive load in both directions at an ambient temperature of 20°C (68°F) and a duty cycle of 40%. A more accurate travel life calculation requires additional application information. Contact customer support for assistance.



Electrak[®] XD – Control Standard Features

All Electrak[®] XD controls, except for the CAN bus options (CNO and COO), have as a minimum the basic Electrak Monitoring Package features and low-level switching, speed control and optional force feedback capabilities as described below. This minimum configuration is called control option LXX.

Electrak Monitoring Package Features

The monitoring package includes:

- Current monitoring - shuts down the actuator on overload.
- Temperature and voltage monitoring - protects the actuator by preventing motion when temperature and/or voltage are outside of normal ranges.
- Temperature compensation - enables normal operation at low temperatures.
- Software controlled end-of-stroke limits - protect the actuator and ensure smooth stops.
- Dynamic braking - produces quick, repeatable stops with no coasting.

Low-level Switching

With low-level switching, the customer-supplied switches/relays that are connected to the extend and retract inputs only need to handle low-level signals and not the voltage and current of the motor.

Speed Control

If the speed control input is not used when the extend and retract inputs are active, the actuator will move at its full speed as long as the max. load is not exceeded. If a 0 - 5 Vdc signal is connected to the speed control input, the speed of the actuator can be regulated between 20 - 100% of its full speed where 0 - 0.5 V corresponds to full speed and 1 - 5 V corresponds to 20% of full speed up to full speed.

Speed vs. Speed Control Input Voltage

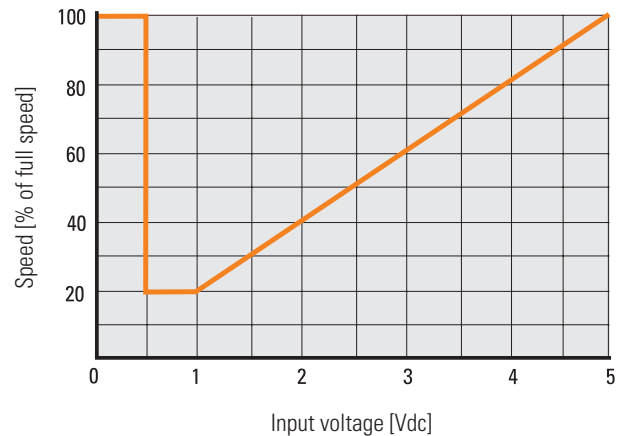

Force Feedback Output

In order to use the force feedback output, the actuator must be equipped with an integral force feedback sensor (rear adapter type K). The force output is a 0 - 5 Vdc signal where 2.5 V is zero force, 0.5 V is 25 kN compression force and 4.5 V is 25 kN tension force. Between 0.5 - 4.5 V, the output changes 1 mV per 12.5 N in change of force.

Force vs. Force Feedback Output Voltage

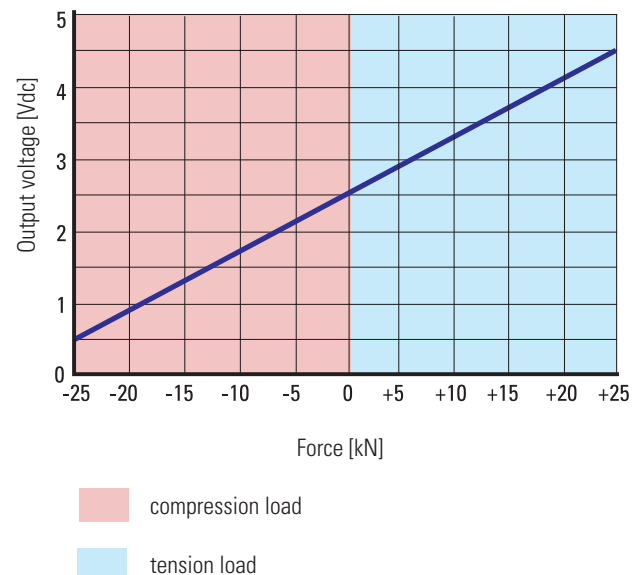

Electrak XD – Ordering Key

Ordering Key								
1	2	3	4	5	6	7	8	9
XD24	B055-	0200	LXX	-	M	M	S	N
<p>1. Model and input voltage XD24 = Electrak XD, 24 Vdc XD48 = Electrak XD, 48 Vdc</p> <p>2. Dynamic load capacity, speed and max. stroke length (S) B055- = 5.5 kN @ 75 mm/s, 1200 mm B080- = 8.0 kN @ 50 mm/s, 1200 mm B160- = 16 kN @ 25mm/s, 1000 mm B200- = 20 kN @ 20 mm/s, 800 mm B250- = 25 kN @ 16 mm/s, 650 mm</p> <p>3. Ordering stroke length (S) ^{(1) (2)} 0100 = 100 mm 0150 = 150 mm 0200 = 200 mm 0250 = 250 mm 0300 = 300 mm 0350 = 350 mm 0400 = 400 mm 0450 = 450 mm 0500 = 500 mm 0550 = 550 mm 0600 = 600 mm 0650 = 650 mm 0700 = 700 mm 0750 = 750 mm 0800 = 800 mm 0900 = 900 mm 0950 = 950 mm 1000 = 1000 mm 1050 = 1050 mm 1100 = 1100 mm 1150 = 1150 mm 1200 = 1200 mm</p>				<p>4. Electrak Modular Control System options ^{(3) (4)} LXX = low-level signal motor switching + speed control + force feedback output LXP = LXX + position feedback output LLX = LXX + end-of-stroke indication outputs LLP = LXX + position feedback output + end-of-stroke indication outputs PLS = LXX + position feedback output + programmable end-of-stroke limits COO = CANopen[®] + closed loop speed control (includes diagnostics, position feedback, overload indication plus static and dynamic force feedback) CNO = CAN bus SAE J1939 + closed loop speed control (includes diagnostics, position feedback, overload indication plus static and dynamic force feedback)</p> <p>5. Manual Brake Release and Override Option – = no manual brake release or override R = manual brake release and override</p> <p>6. Rear adapter option M = 16 mm cross hole N = 16 mm forked cross hole H = M20 × 1.5 male thread K = force feedback sensor with 16 mm cross hole ^{(4) (5)}</p> <p>7. Front adapter option M = 16 mm cross hole N = 16 mm forked cross hole H = M20 × 1.5 male thread P = M20 × 1.5 female thread</p> <p>8. Adapter orientation S = standard M = 90° turned</p> <p>9. Mechanical shock load dampening ⁽⁵⁾ N = no dampening M = dampening</p> <p><small>(1) Max. possible stroke length depends on the dynamic load capacity, see position 2. (2) Other stroke lengths available upon request. Please contact customer support. (3) All Electrak XD are as standard equipped with the Electronic Monitoring Package. (4) To use the force feedback function, the actuator must be equipped with rear adapter type K. (5) To equip the actuator with the mechanical shock load dampening option, it also must be equipped with the rear adapter type M. This configuration will render the actuator incompatible with the force feedback option as it requires rear adapter type K.</small></p>				



Electrak® XD – Mechanical Options

Manual Brake Release and Override Type R		
Weight of option	[kg (lbs)]	0.71 (1.56)
Manual brake release specifications		
Brake release lever pull operation force for full brake release	[N (lbf)]	40 (15)
Brake release lever operation pull distance for full brake release	[mm (in)]	10 (0.4)
Brake lever inside hole thread (a)		10-32"
Brake lever bracket mounting holes (b)		M5
Manual override specifications		
Required override input torque @ full load	[Nm (lbf-in)]	6 (53.1)
Max. permissible override input torque	[Nm (lbf-in)]	9 (79.7)
Max. override input speed	[rpm]	500
Linear movement / override input turn	[mm]	
XDxx-B055		1.3
XDxx-B080		1.3
XDxx-B160		0.5
XDxx-B200		0.31
XDxx-B250		0.31
Rotational direction of the input		
clockwise seen from front		tube extends
counter clockwise seen from front		tube retracts
Maximum run time	[min]	1
Cool-down time between operations	[min]	5
Manual override input hex key sizes	[mm]	
cover plug (c) and		8
override input shaft		8

Electrak® XD can be equipped with the manual brake release and override option, which allows the extension tube to be released and/or manually cranked back and forth.

Manual Brake Release

When engaged, the manual brake release will release the extension tube from the brake so that it can move freely. In case of a helping load, the operator must ensure releasing the extension tube will not create a hazardous situation since the tube will immediately move in the direction the force is acting.

It is also critical when releasing a helping load that the actuator is connected to a power source or any other device that can take the regenerated energy from the motor when it is acting as a generator. In order to operate the brake release lever, (a) must be pulled. The mounting holes (b) are provided so that a bracket can be easily installed as a support for a cable assembly used for remote lever operation. To release the brake completely, the lever needs to be pulled in 10 mm (0.4 in) with a force of 40 N (15 lbf). Shorter distance and lower force will open the brake partially and allow for a slower, more controlled movement.

Manual Override Input

Access is granted to the manual override shaft input head (c) by removing the cover plug. Using a hex bit as a crank allows the extension tube to be moved back and forth. Using the manual override does not require the manual brake release to be operated as the override input will disengage the brake by itself while being used. A power tool can be used to operate the manual override as long as it starts and stops smoothly and the input speed doesn't exceed 500 rpm. The override has a maximum run time of one minute and requires a five-minute cool-down between events.

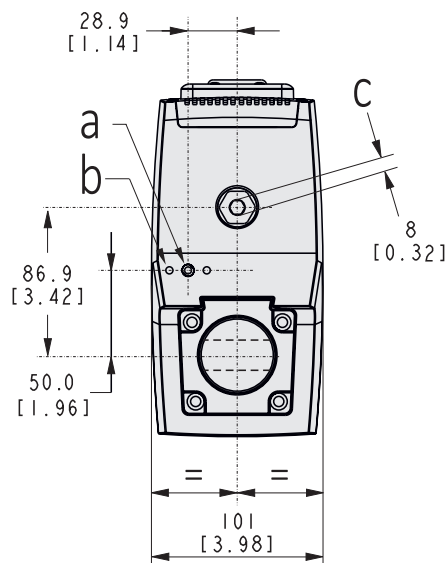

Shock Load Dampening Type M		
Max. shock load force	[kN (lbf)]	48 (10791)
Max. dampening distance (max. Ldd)	[mm (in)]	± 2.7 (0.11)
Weight of option	[kg (lbs)]	1.16 (2.56)
Operating temperature limits	[°C (F)]	-40 – 85 (-40 – 185)
Life expectancy		as the actuator
Maintenance		not required

Electrak XD can be equipped with the shock load dampening option, which will absorb shock loads and thus increase the life of the actuator. The dampener consists of a rear adapter combined with a dampener unit that replaces the standard adapter, adding to the total length and weight of the actuator.

Shock Load Dampener

When an extension tube equipped with the shock load dampening option is subjected to a shock load, the dampener will be extended or compressed depending on the direction of the shock load force before returning to its original position. The distance is mainly related to the shock load force (as seen in the diagram), but the load, temperature, shock load speed and mounting position will also affect the distance.

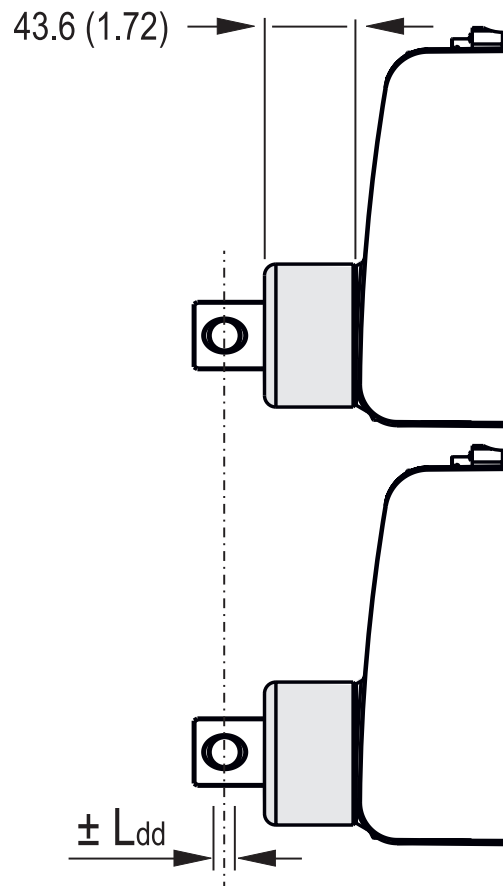

Dampening Distance vs. Shock Load

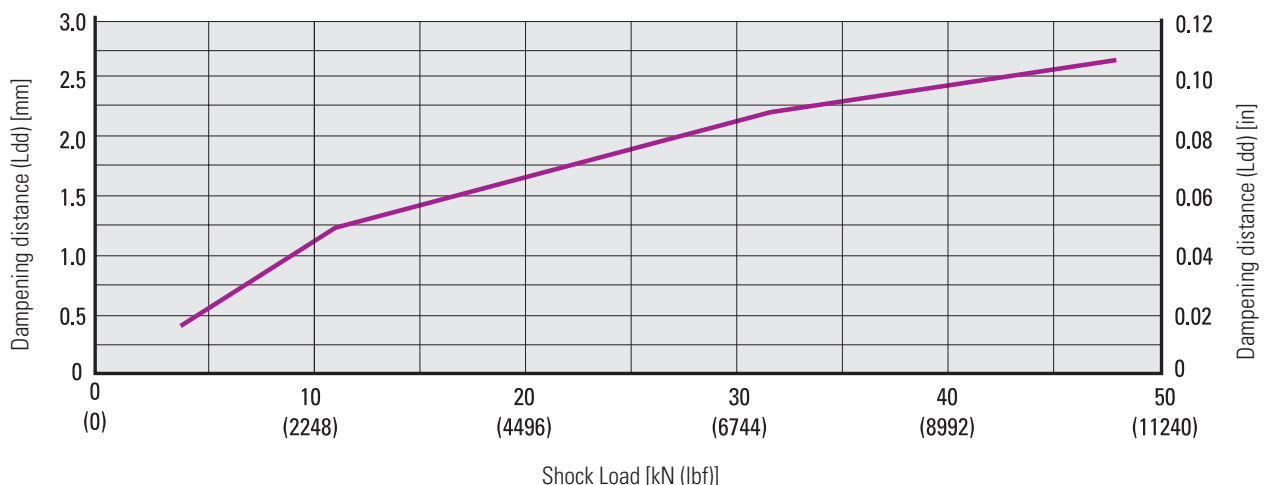



Electrak® XD – Control Options

All Control Options		
Actuator supply voltage limits	[Vdc]	
XD24		18 - 32
XD48		36 - 60
Current draw @ min. / max. load	[A]	
XD24-Bxxx		6 / 28
XD48-Bxxx		3 / 14
End-of-stroke protection		yes
Overload protection		yes
Temperature monitoring		yes
Temperature compensation		yes
Voltage monitoring		yes
Current monitoring		yes
Speed control possible by supply voltage PWM		no

Fuse

Use a slow blow fuse on the supply voltage input wiring to protect the actuator and the wiring. Size it in accordance with local regulations and the current draw for the application in question.

Voltage Drop

Long supply wires may need an increased cross section in order to prevent the supply voltage to drop to levels below the supply voltage limit of the actuator. Calculations to determine the necessary cross section should take local regulations, application specifics and the actuator supply voltage limits into account.

Speed Control by Pulse Width Modulation (PWM)

The actuator speed can't be changed by PWM control of the supply voltage as the actuator may be harmed by this action. Speed of the actuator can only be controlled by using the speed control input or the CAN bus speed control commands.

Regeneration Current with Helping Load

When encountering a helping load, the motor acts as a generator and it is important to ensure that the power supply used can handle the power generated back by the motor.

Control Option Type LXX

Extend / retract input voltage	[Vdc]	9 - 64
Extend / retract input current	[mA]	0.35 - 2.75
Speed control input voltage range	[Vdc]	0.5 - 5
Speed control range of full speed	[%]	20 - 100
Force feedback output voltage range *	[Vdc]	0.5 - 4.5
Force feedback linearity*	[%]	± 5
Force feedback resolution*	[N/mV]	12.5

*To be able to use the force feedback output the actuator need to be equipped with the rear adapter option type K that includes the force feedback sensor.

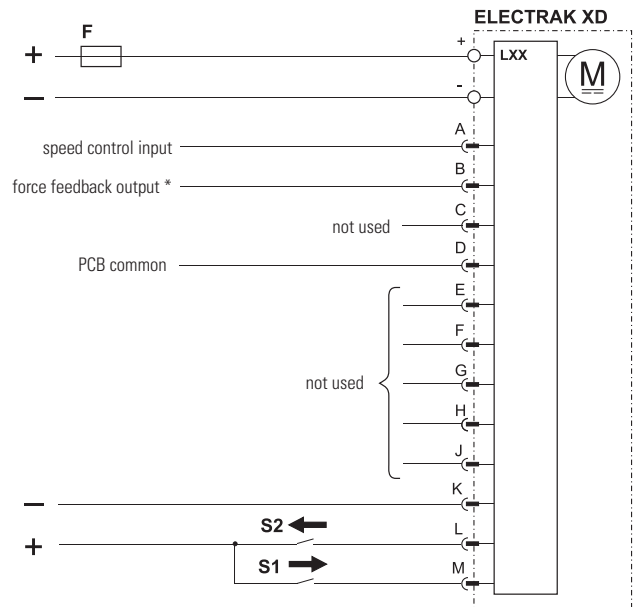
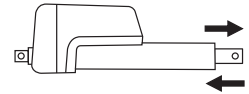

- + / - Supply voltage positive / negative
- F Fuse
- S1 Extend switch/relay
- S2 Retract switch/relay

Control option LXX includes all of the basic Electrak Monitoring Package features plus low-level switching, speed control and force feedback capabilities ⁽¹⁾.

(1) To be able to use the force feedback output the actuator need to be equipped with the rear adapter option type K that includes the force feedback sensor.

Control Option Type LLX

Extend / retract input voltage	[Vdc]	9 - 64
Extend / retract input current	[mA]	0.35 - 2.75
Speed control input voltage range	[Vdc]	0.5 - 5
Speed control range of full speed	[%]	20 - 100
Force feedback output voltage range	[Vdc]	0.5 - 4.5
Force feedback linearity	[%]	± 5
Force feedback resolution	[N/mV]	12.5
End-of-stroke output contact type		potential free
Max. end-of-stroke output voltage	[Vdc/ac]	30/120
Max. end-of-stroke output current	[mA]	100

*To be able to use the force feedback output the actuator need to be equipped with the rear adapter option type K that includes the force feedback sensor.

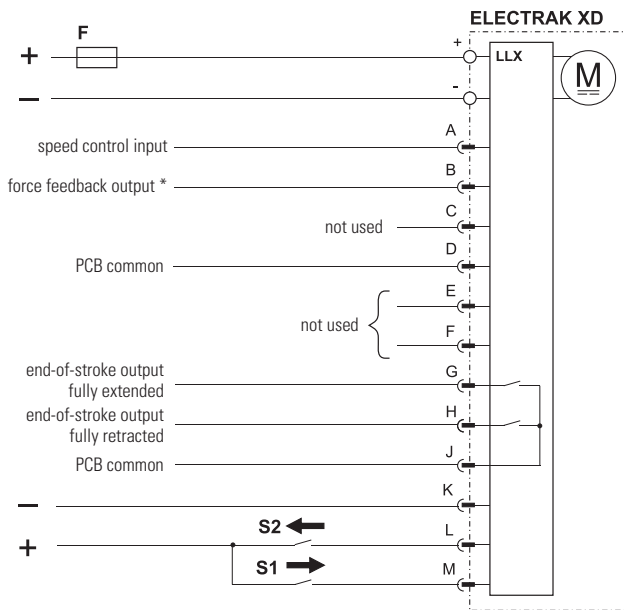
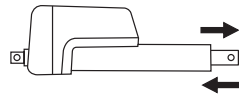

- + / - Supply voltage positive / negative
- F Fuse
- S1 Extend switch/relay
- S2 Retract switch/relay

Control option LLX works as option LXX but also includes two end-of-stroke outputs that indicate when the extension tube is in its fully extended or retracted position.

Control Option Type LXP

Extend / retract input voltage	[Vdc]	9 - 64
Extend / retract input current	[mA]	0.35 - 2.75
Speed control input voltage range	[Vdc]	0.5 - 5
Speed control range of full speed	[%]	20 - 100
Force feedback output voltage range	[Vdc]	0.5 - 4.5
Force feedback linearity	[%]	± 5
Force feedback resolution	[N/mV]	12.5
Position feedback output voltage	[Vdc]	0.5 - 4.5
Position feedback linearity	[%]	± 0.25
Position feedback resolution	[mm/V]	ordering stroke length (S) [mm] / 4

*To be able to use the force feedback output the actuator need to be equipped with the rear adapter option type K that includes the force feedback sensor.

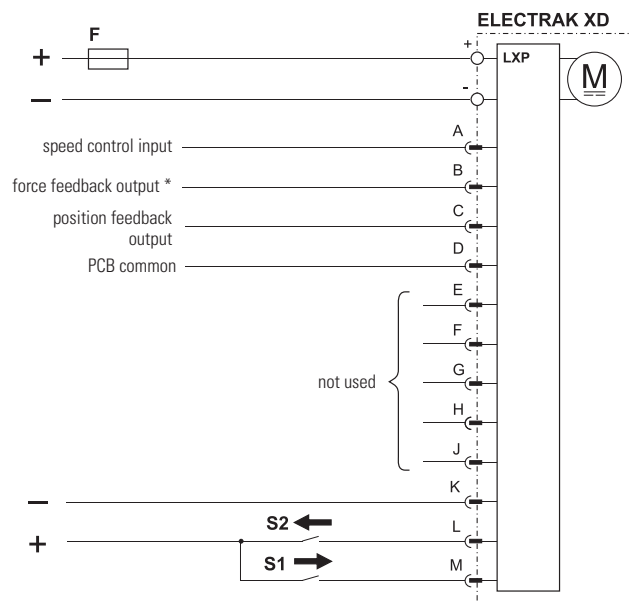
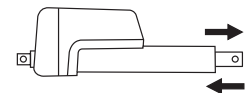

- + / - Supply voltage positive / negative
- F Fuse
- S1 Extend switch/relay
- S2 Retract switch/relay

Control option LXP works as option LXX but also includes an analog position output that will provide feedback on the extension tube position.



Electrak® XD – Control Options

Control Option Type LLP

Extend / retract input voltage	[Vdc]	9 - 64
Extend / retract input current	[mA]	0.35 - 2.75
Speed control input voltage range	[Vdc]	0.5 - 5
Speed control range of full speed	[%]	20 - 100
Force feedback output voltage range*	[Vdc]	0.5 - 4.5
Force feedback linearity*	[%]	± 5
Force feedback resolution*	[N/mV]	12.5
End-of-stroke output contact type		potential free
Max. end-of-stroke output voltage	[Vdc/ac]	30/120
Max. end-of-stroke output current	[mA]	100
Position feedback output voltage	[Vdc]	0.5 - 4.5
Position feedback linearity	[%]	± 0.25
Position feedback resolution	[mm/V]	ordering stroke length (S) [mm] / 4

*To be able to use the force feedback output the actuator need to be equipped with the rear adapter option type K that includes the force feedback sensor.

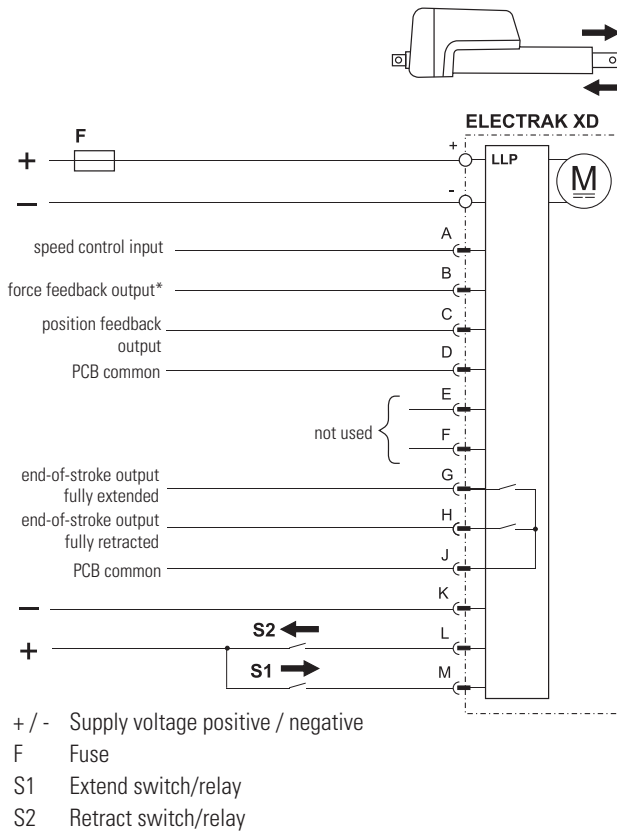

Control option LLP works as option LXP but also includes two end-of-stroke outputs that indicate when the extension tube is in its fully extended or retracted position.

Control Option Type PLS

Extend / retract input voltage	[Vdc]	9 - 64
Extend / retract input current	[mA]	0.35 - 2.75
Speed control input voltage range	[Vdc]	0.5 - 5
Speed control range of full speed	[%]	20 - 100
Force feedback output voltage range*	[Vdc]	0.5 - 4.5
Force feedback linearity*	[%]	± 5
Force feedback resolution*	[N/mV]	12.5
Position feedback output voltage	[Vdc]	0.5 - 4.5
Position feedback linearity	[%]	± 0.25
Position feedback resolution	[mm/V]	ordering stroke length (S) [mm] / 4

*To be able to use the force feedback output the actuator need to be equipped with the rear adapter option type K that includes the force feedback sensor.

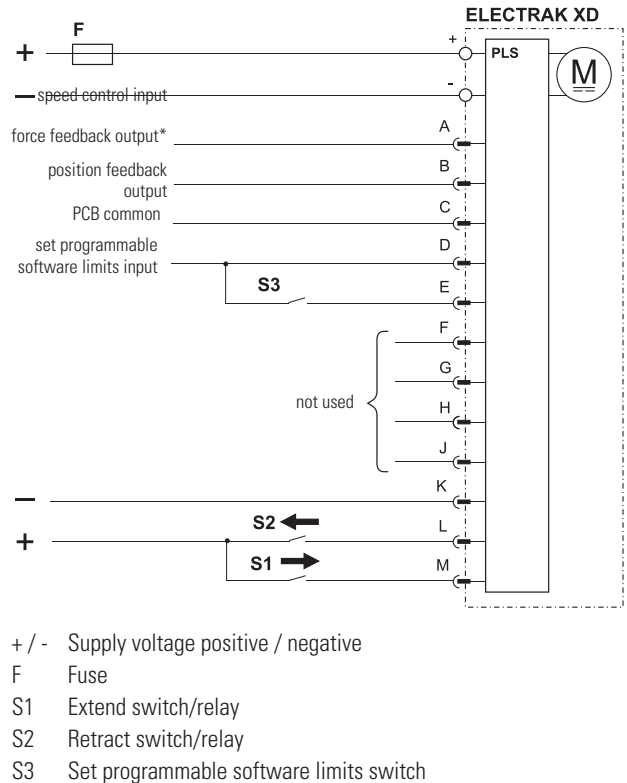
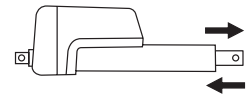

Control option PLS works as option LXP but also includes programmable software extend and retract limits.

Control Option Type CNO and COO

Command data includes:

- position
- speed
- current

Feedback data includes:

- position
- speed
- current
- force (the actuator must also be equipped with the force feedback rear adapter type K)
- other diagnostic information

Extend / retract input voltage	[Vdc]	9 - 64
Extend / retract input current	[mA]	0.35 - 2.75

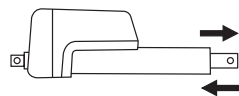

Control option CNO includes a SAE J1939 CAN bus control interface, COO includes a CANopen® control interface that controls and monitors the actuator. Movement commands are sent via CAN messages on the CAN low and CAN high inputs. Inputs on pins G, H and J can be used as a binary coded decimal (BCD) adder to change the default address of the actuator. This option can be used when multiple CAN bus actuators are located on a single bus. The actuator can be manually forced to extend or retract by using the inputs on pin L and M. When the manual control inputs are used, CAN bus control messages are ignored, but the unit will still provide CAN bus feedback messages. When the inputs are left floating, CAN bus functionality for control messages is restored. When using the address inputs and/or the manual extend and retract switches, pin K must be connected to supply voltage negative.

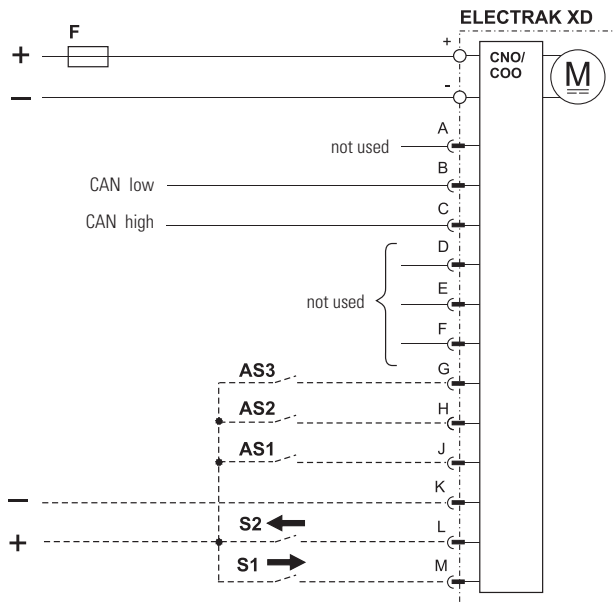

- + / - Supply voltage positive / negative
- F Fuse
- S1 Manual extend switch/relay (optional)
- S2 Manual retract switch/relay (optional)
- AS1 Address selection switch for binary position 1
- AS2 Address selection switch for binary position 2
- AS3 Address selection switch for binary position 3



Electrak[®] XD – Accessories

Signal Cable and Connector Harness		
Length without connector	[mm (in)]	1500 (59)
Lead cross section/size	[mm ² (AWG)]	0.5 (20)
Pin to lead color		A - pink B - brown C - blue D - black E - orange/black F - yellow/black G - white H - red J - green K - grey L - orange M - violet
Part number		954-9476

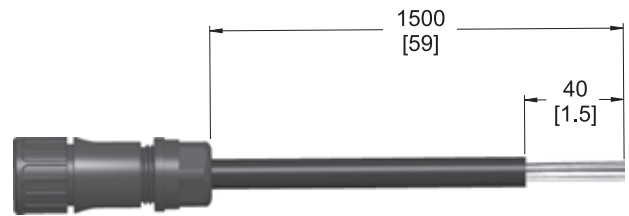

Notes