



Electrak® LA24 – Technical Features



Standard Features

- Robust and reliable
- 1 × 230 or 3 × 400 Vac as standard input voltages
- Acme and ball screw models
- Static load up to 18 kN (4000 lbf)
- Dynamic load up to 4.5 kN (1000 lbf)
- Stroke up to 24 in
- Speed up to 61 mm/s (2.4 in/s)
- Protection class static IP45
- Overload clutch for mid and end of stroke protection
- Motor with thermal switch
- Corrosion free aluminium cover tube
- Anti-rotation mechanism
- T-slots in the cover tube for magnetic sensors
- Maintenance free

General Specifications

Screw type	acme or ball
Nut type Dxx-xxA (acme screw) Dxx-xxB (ball screw)	self-locking lead nut load lock ball nut
Manual override	no (optional)
Anti-rotation	yes
Static load holding brake acme screw models ball screw models	no (self-locking) yes
Safety features	overload clutch motor auto reset thermal switch
Electrical connections no potentiometer option with potentiometer option	cable with flying leads 2 x cable with flying leads
Compliances	CE, UKCA
Certificates	UL, CSA

(1) Mating connector: 2973781 with terminal 2962573 (p/n 9100-448-001)

Optional Mechanical Features

- Variety of front and rear adapters
- Variety of rear adapter orientations
- Manual override

Optional Electrical Features

- Potentiometer feedback
- Anti-coast brake

Accessories

- External slot-mounted limit switches
- Mounting pin kits
- Mounting pin bracket kits
- Trunnions mounting kits
- Capacitors

Compatible Controls

Contact customer support at www.thomsonlinear.com/cs

Electrak LA24 – Technical Specifications

Mechanical Specifications		
Max. static load ⁽¹⁾ Axx-xxA (acme screw) Axx-xxB (ball screw)	[N (lbf)]	11350 (2500) 18000 (4000)
Max. dynamic load (Fx) AA12(22)-05A65M ⁽²⁾ AA12(22)-10A65M AA42-10A65M AA12(22)-20A65M AA42-20A65M AA12(22)-05B65M AA42-05B65M AA12(22)-10B65M AA42-10B65M AA12(22)-20B65M AA42-20B65M	[N (lbf)]	1100 (250) 2250 (500) 1100 (250) 2250 (500) 1100 (250) 2250 (500) 1100 (250) 4500 (1000) 2250 (500) 4500 (1000) 2250 (500)
Speed @ no load/max. load AAxx-05A65M ⁽²⁾ AAxx-10A65M AAxx-20A65M AAxx-05B65M AAxx-10B65M AAxx-20B65M	[mm/s (in/s)]	54/32 (2.10/1.20) 30/18 (1.20/0.70) 15/12 (0.67/0.45) 61/37 (2.40/1.40) 30/18 (1.30/0.71) 15/12 0.60/0.47)
Min. ordering stroke (S) length	[mm]	50
Max. ordering stroke (S) length	[mm]	600
Ordering stroke length increments	[mm]	50
Operating temperature limits	[°C (F)]	-25 – 65 (-15 – 150)
Max. on time	[s]	45
Full load duty cycle @ 25 °C (77 °F)	[%]	25
End play, maximum	[mm (in)]	1.0 (0.04)
Restraining torque	[Nm (lbf-in)]	0
Protection class - static		IP45
Salt spray resistance	[h]	96

(1) Max. static load at fully retracted stroke

(2) Not possible with supply voltage 3 × 400 Vac

Electrical Specifications		
Available input voltages ⁽¹⁾	[Vac]	1 × 230 ⁽²⁾ 3 × 400
Input voltage tolerance	[%]	± 10
Current draw @ no load/max. load AA22-05A65M AA22-10A65M AA22-20A65M AA22-05B65M AA22-10B65M AA22-20B65M AA42-10A65M AA42-20A65M AA42-05B65M AA42-10B65M AA42-20B65M	[A]	1.05/1.60 0.80/1.60 0.95/1.50 0.90/1.40 0.90/1.40 0.90/1.40 0.40/0.70 0.30/0.45 0.38/0.50 0.38/0.50 0.38/0.50
Motor cable length	[mm (in)]	600 (24)
Motor cable diameter	[mm (in)]	10 (0.4)
Motor cable leads cross section	[mm ² (AWG)]	1.5 (16)
Potentiometer cable length ⁽³⁾	[mm (in)]	500 (20)
Potentiometer cable diameter ⁽³⁾	[mm (in)]	9 (0.35)
Pot. cable leads cross section ⁽³⁾	[mm ² (AWG)]	1.5 (16)

(1) For other input voltages - contact customer

(2) Capacitor required to run the actuator. 10 µF, p/n 9200-448-003

(3) Potentiometer is optional



Electrak® LA24 – Dimensions

Dimensions	Projection
mm [inch]	

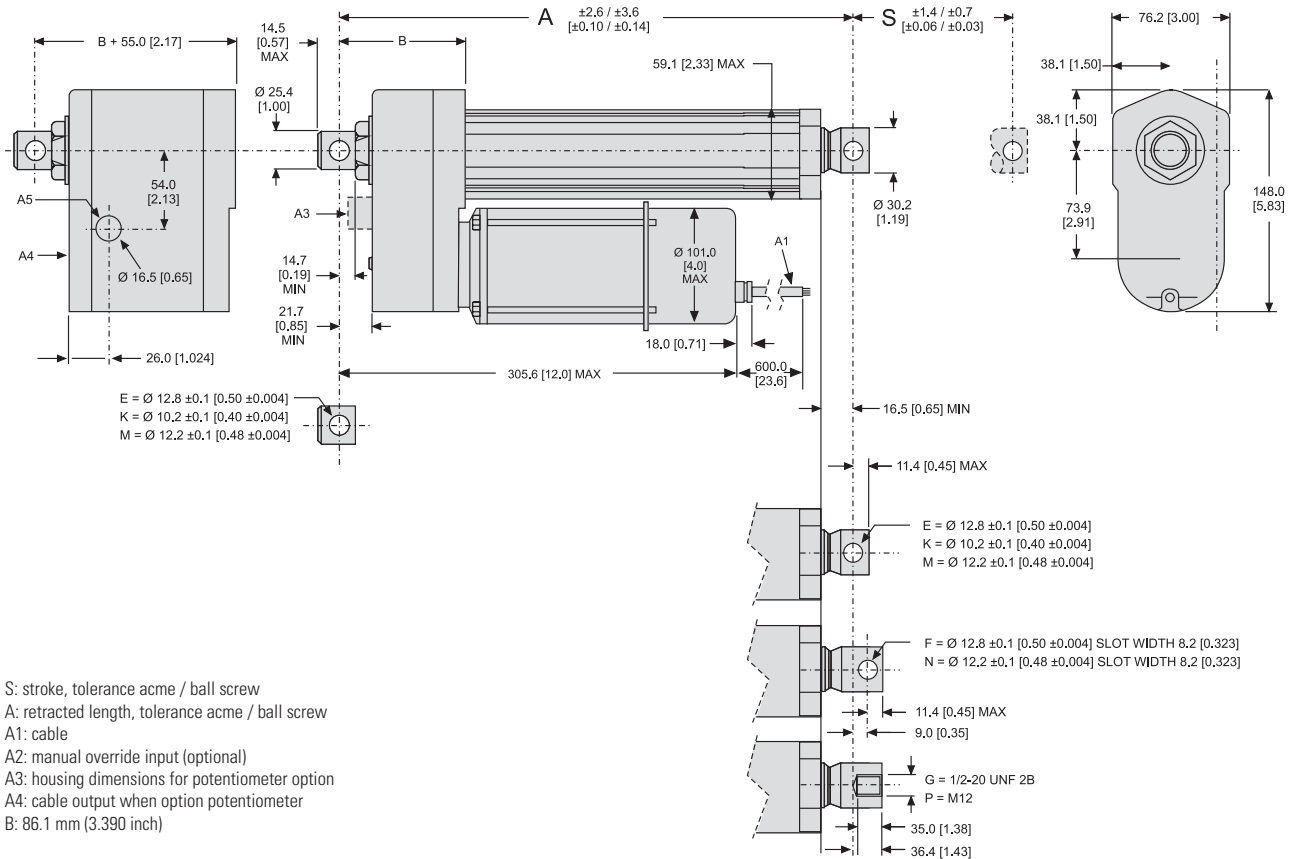

Stroke, Retracted Length and Weight Relationships

Ordering stroke (S)	[mm]	50	100	150	200	250	300	350	400	450	500	550	600
Retracted length, acme screw models (A)	[mm]	219.9	269.9	319.9	369.9	419.9	469.9	586.6	636.6	686.6	736.6	786.6	836.6
	[in]	8.86	10.62	12.59	14.56	16.53	18.50	23.09	25.06	27.03	29.00	30.97	32.94
Retracted length, ball screw models (A)	[mm]	269.6	319.6	369.6	419.6	469.6	519.6	623.4	673.4	723.5	773.4	823.4	873.4
	[in]	10.61	12.58	14.55	16.52	18.49	20.46	24.54	26.51	28.48	30.45	32.42	34.39
Add on length for option potentiometer	[mm]	55.0											
	[in]	2.17											
Weight, acme screw models	[kg]	6.0	6.2	6.4	6.6	6.8	7.0	7.3	7.5	7.7	7.9	8.1	8.3
	[lbs]	13.2	13.6	14.1	14.5	15.0	15.4	16.1	16.5	16.9	17.4	17.8	18.3
Weight, ball screw models	[kg]	6.8	7.0	7.2	7.4	7.6	7.8	8.1	8.3	8.5	8.7	8.9	9.1
	[lbs]	15.0	15.4	15.8	16.3	16.7	17.2	17.8	18.3	18.7	19.1	19.6	20.0
Add on weight for option potentiometer	[kg]	1.30											
	[lbs]	3.31											

Electrak LA24 – Performance Diagrams

Acme Screw Models
Speed and Current vs. Load

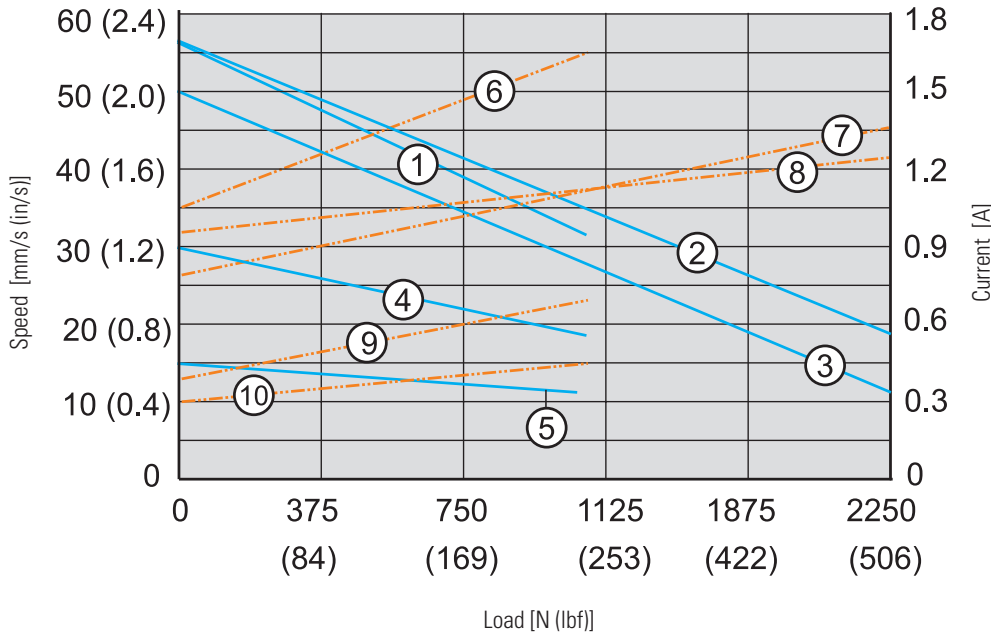

Speed

- 1: AA22-05A65M
- 2: AA22-10A65M
- 3: AA22-20A65M
- 4: AA42-10A65M
- 5: AA42-20A65M

Current

- 6: AA22-05A65M
- 7: AA22-10A65M
- 8: AA42-20A65M
- 9: AA42-10A65M
- 10: AA42-20A65M

Ball Screw Models
Speed and Current vs. Load

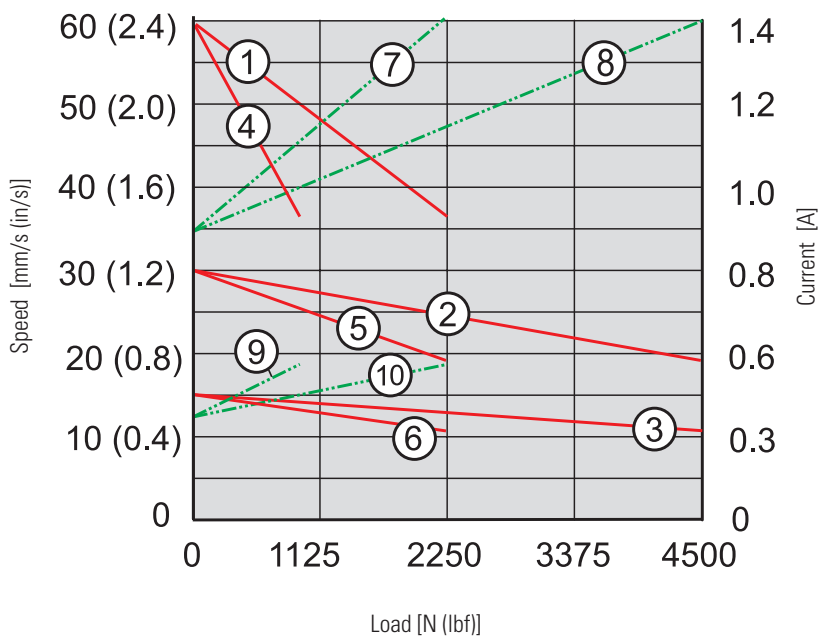

Speed

- 1: AA22-05B65M
- 2: AA22-10B65M
- 3: AA22-20B65M
- 4: AA42-05B65M
- 5: AA42-10B65M
- 6: AA42-20B65M

Current

- 7: AA22-05B65M
- 8: AA22-10B65M
- AA22-20B65M
- 9: AA42-05B65M
- 10: AA42-10B65M
- AA42-20B65M



Electrak® LA24 – Ordering Key

Ordering Key

1	2	3	4	5	6	7
AA22-05A65M	10	M0	N	-D	F	M

1. Model, input voltage, dynamic load capacity, screw type, maximum speed

- AA22-05A65M = Electrak LA24, 1 × 230 Vac, 1100 N, acme, 54 mm/s
- AA22-10A65M = Electrak LA24, 1 × 230 Vac, 2250 N, acme, 30 mm/s
- AA22-20A65M = Electrak LA24, 1 × 230 Vac, 2250 N, acme, 15 mm/s
- AA22-05B65M = Electrak LA24, 1 × 230 Vac, 2250 N, ball, 61 mm/s
- AA22-10B65M = Electrak LA24, 1 × 230 Vac, 4500 N, ball, 30 mm/s
- AA22-20B65M = Electrak LA24, 1 × 230 Vac, 4500 N, ball, 15 mm/s
- AA42-10A65M = Electrak LA24, 3 × 400 Vac, 1100 N, acme, 30 mm/s
- AA42-20A65M = Electrak LA24, 3 × 400 Vac, 1100 N, acme, 15 mm/s
- AA42-05B65M = Electrak LA24, 3 × 400 Vac, 1100 N, ball, 61 mm/s
- AA42-10B65M = Electrak LA24, 3 × 400 Vac, 2250 N, ball, 30 mm/s
- AA42-20B65M = Electrak LA24, 3 × 400 Vac, 2250 N, ball, 15 mm/s

2. Ordering stroke length

- 05 = 50 mm
- 10 = 100 mm
- 15 = 150 mm
- 20 = 200 mm
- 25 = 250 mm
- 30 = 300 mm
- 35 = 350 mm
- 40 = 400 mm
- 45 = 450 mm
- 50 = 500 mm
- 55 = 550 mm
- 60 = 600 mm

3. Rear / front adapter hole position ⁽¹⁾

- M0 = both adapters at 0° (standard position)
- MF = both adapters at 90°

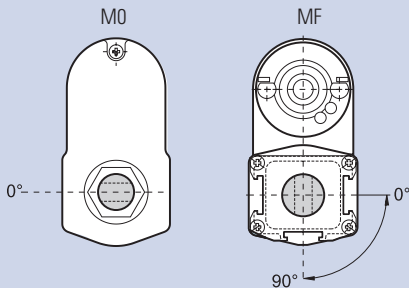

4. Options

- N = no option
- B = anti-coast brake ⁽²⁾
- NPO = potentiometer
- NHW = manual override ⁽¹⁾
- BPO = anti-coast brake and potentiometer ⁽²⁾
- BHW = anti-coast brake and manual override ⁽²⁾

Dimensions for manual override option

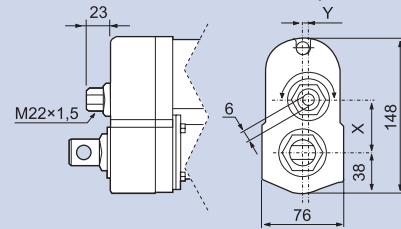

Model	X	Y
DAxx05A(B)65-	49.6	0.0
DAxx10A(B)65-	43.3	5.2
DAxx20(21)A(B)65-	38.9	0.0

5. Connector option

- D = no connector (flying leads)

6. Front adapter option

- E = cross hole for 0.5 inch pin
- F = forked cross hole for 0.5 inch pin
- G = 1/2-20 UNF 2B female thread
- K = cross hole for 10 mm pin
- M = cross hole for 12 mm pin
- N = forked cross hole for 12 mm pin
- P = M12 female thread

7. Rear adapter option

- E = cross hole for 0.5 inch pin
- K = cross hole for 10 mm pin
- M = cross hole for 12 mm pin

(1) Only adapter position M0 possible with option manual override.

(2) Ball screw versions must always be ordered with anti-coast brake while acme versions can be ordered with or without.

Electrak LA24 – Electrical Connections

Input Voltage 230 Vac		
Actuator supply voltage AA22-	[Vac]	1 × 230

Input Voltage 400 Vac		
Actuator supply voltage AA42-	[Vac]	3 × 400

No anti-coast brake

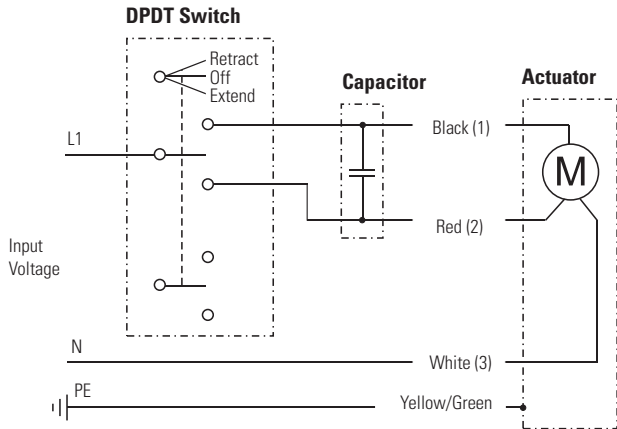

No anti-coast brake

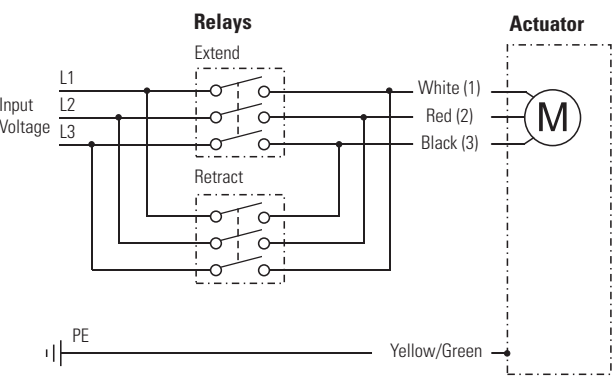

With anti-coast brake

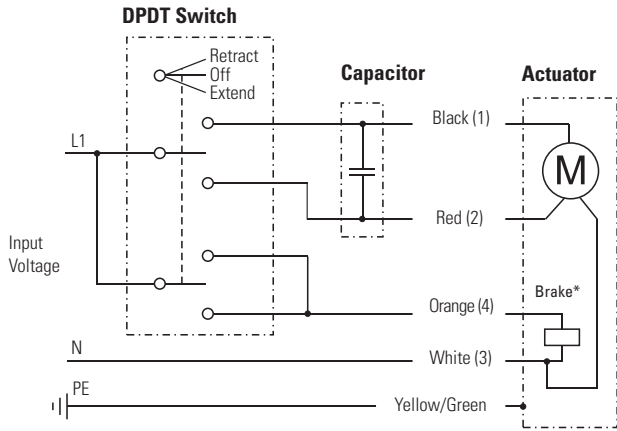

With anti-coast brake

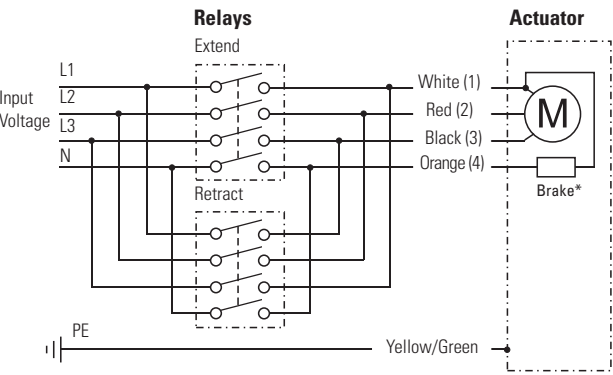

Leads can be either color or number marked. To be able to run the actuator, a 10 µF capacitor must be connected between black (1) and red (2) leads. See page 72 for ordering of capacitors. Connect black (1) lead to L1 and white (3) lead to N (neutral) to retract the actuator. Change L1 from lead black (1) to lead red (2) to extend the actuator. If the actuator has an anti-coast brake*, it must be released during motion, which is done by connecting orange (4) lead to L1.

Leads can be either color or number marked. Connect white (1) lead to L1, red (2) lead to L2 and black (3) lead to L3 to extend the actuator. Change the places of white (2) lead and black (3) to retract the actuator. If the actuator has an anti-coast brake*, it must be released during motion, which is done by connecting orange (4) lead to N (neutral).



Electrak® LA24 – Electrical Connections

Input Voltage 230 Vac + Option Potentiometer		
Actuator supply voltage AA22-	[Vac]	1 × 230
Potentiometer type		wire-wound
Potentiometer max. input voltage	[Vdc]	32
Potentiometer max. power	[W]	2
Potentiometer linearity	[%]	± 0.25
Potentiometer output resolution	[ohm/mm]	
50 - 255 mm stroke		39
256 - 510 mm stroke		20
511 - 600 mm stroke		10

Leads can be either color or number marked. To be able to run the actuator, a 10 µF capacitor must be connected between black (1) and red (2) leads. See page 72 for ordering of capacitors. Connect black (1) lead to L1 and white (3) lead to N (neutral) to retract the actuator. Change L1 from lead black (1) to lead red (2) to extend the actuator. If the actuator has an anti-coast brake*, it must be released during motion, which is done by connecting orange (4) lead to L1. The potentiometer output cable has 0 ohm between gray and yellow leads when the actuator is fully extended.

No anti-coast brake

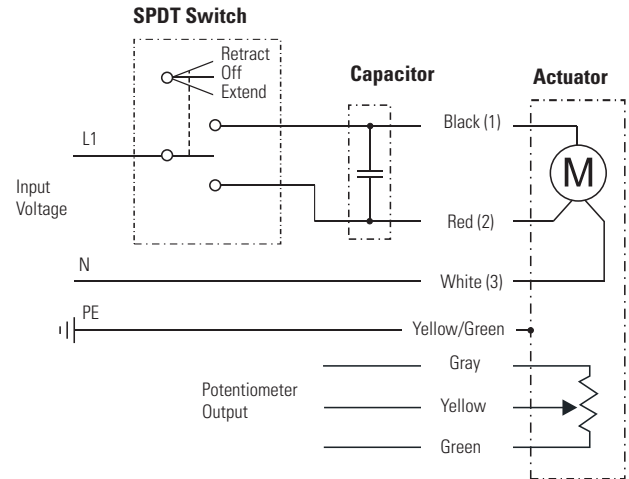

With anti-coast brake

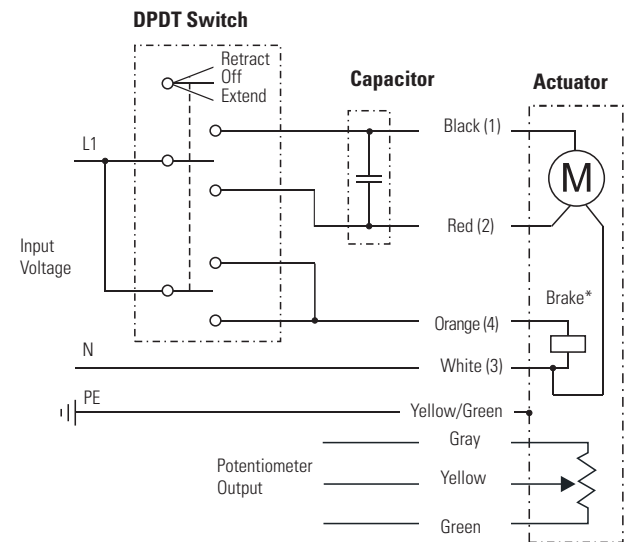

Input Voltage 400 Vac + Option Potentiometer

Actuator supply voltage AA42-	[Vac]	3 × 400
Potentiometer type		wire-wound
Potentiometer max. input voltage	[Vdc]	32
Potentiometer max. power	[W]	2
Potentiometer linearity	[%]	± 0.25
Potentiometer output resolution	[ohm/mm]	
50 - 255 mm stroke		39
256 - 510 mm stroke		20
511 - 600 mm stroke		10

Leads can be either color or number marked. Connect white (1) lead to L1, red (2) lead to L2 and black (3) lead to L3 to extend the actuator. Change the places of white (2) lead and black (3) to retract the actuator. If the actuator have an anti-coast brake*, it must be released during motion, which is done by connecting orange (4) lead to N (neutral). The potentiometer output cable has 0 ohm between gray and yellow leads when the actuator is fully extended.

No anti-coast brake

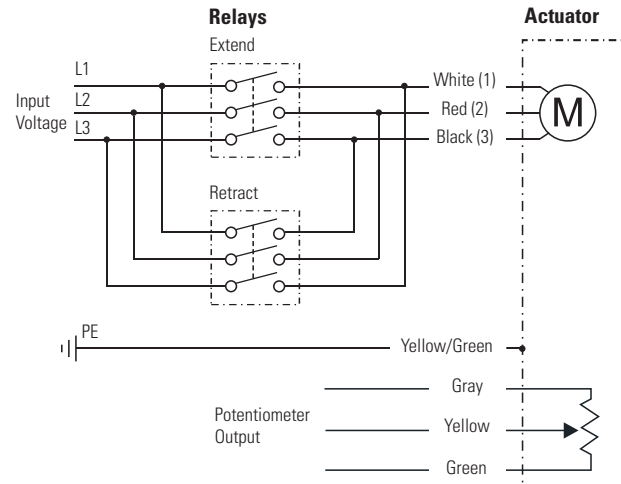

With anti-coast brake

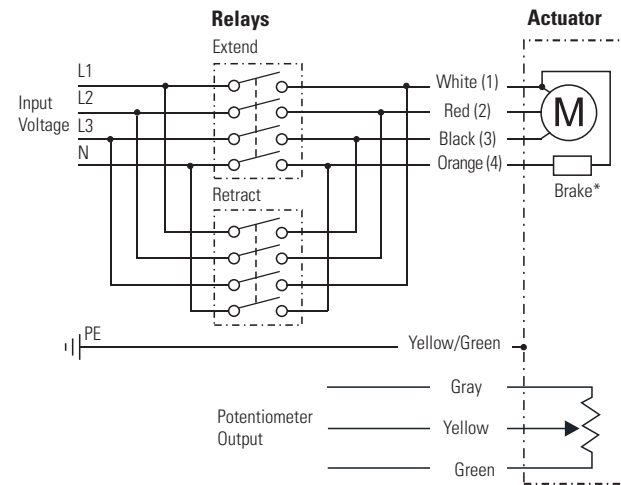

Electrak® LA24 – Accessories

Capacitor Kits

Designation	Actuator Supply Voltage	Part Number
Capacitor kit	230 Vac	9200-448-003

All 230 Vac actuators require a capacitor to be wired between the windings to run. The capacitor is bought separately and mounted externally by the customer.

Mounting Pin Kits

Designation	A [mm (in)]	Part Number
Mounting pins (pair)	12 (0.47)	D603 023

The mounting pins are used in the rear and front adapter holes of the actuator. The pins have a groove in each end so that it can be secured with snap rings.

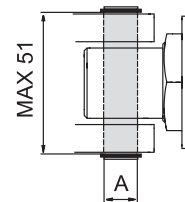

Dimensions
mm

Magnetic Sensor

Designation	Contact Type	Part Number
Magnetic sensor	normally open	D535 070
Magnetic sensor	normally closed	D535 071
Magnetic sensor	changing	D535 073

Specifications

Parameter	D535 070 D535 071	D535 073
Maximum power [W]	10	10
Maximum voltage [Vdc]	100	100
Maximum current [A]	0,5	0,5
Maximum contact resistance [ohm]	20	20
Lead cross section [mm ²]	2 × 0,14	3 × 0,14
Cable length [mm]	3000	3000
Protection class	IP67	IP67

The magnetic sensor fits in to the T-slot running along three sides of the cover tube. The cable is moulded into the sensor.

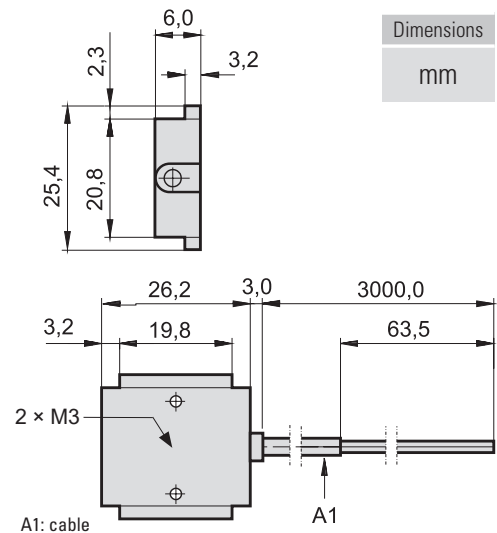

Dimensions
mm

Mounting Pin Bracket Kits

Designation	Part Number
Mounting pin brackets (pair)	D603 029

The mounting pin brackets are used to attach the front and rear adapter via a pair of mounting pins to the objects to which it is mounted. Note! one pair of brackets is needed per adapter as there must be a bracket on each side of the adapter.

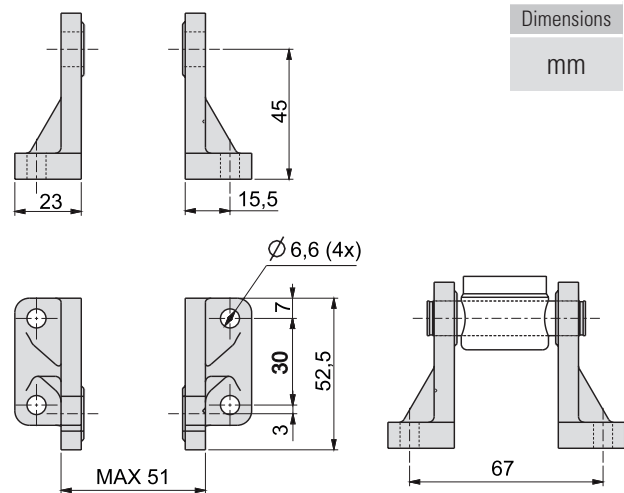

Dimensions
mm

Trunnion Mounting Kits

Designation	Part Number
Trunnions (pair)	D603 022
Trunnion brackets (pair)	D603 030

The trunnions can be mounted to the T-slot running along the right and left side of the cover tube.

Trunnions

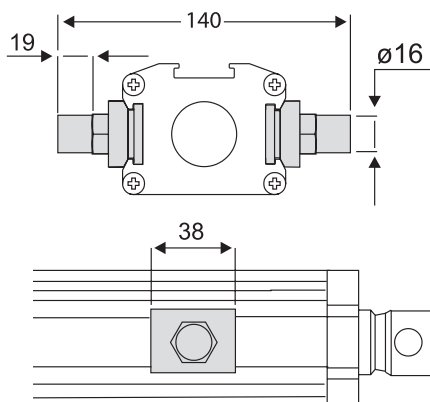

Dimensions
mm

Trunnion Brackets

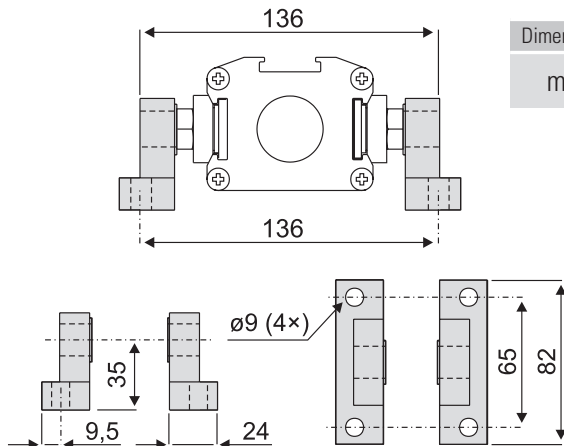

Dimensions
mm