



# Electrak® GX DC – Technical Features



## Standard Features

- Robust and reliable
- 12, 24, 36, 48 or 90 Vdc as standard input voltages
- Acme and ball screw models
- Static load up to 18 kN (4000 lbf)
- Dynamic load up to 9 kN (2000 lbf)
- Stroke up to 24 in (609 mm)
- Speed up to 61 mm/s (2.4 in/s)
- Protection class static IP66
- Overload clutch for mid and end of stroke protection
- Motor with thermal switch
- Maintenance free

## General Specifications

Screw type	acme or ball
Nut type Dxxx-xxA (acme screw) Dxxx-xxB (ball screw)	self locking lead nut load lock ball nut
Manual override	no (optional)
Anti-rotation	no
Static load holding brake acme screw models ball screw models	no (self locking) yes
Safety features	overload clutch motor auto reset thermal switch
Electrical connections no potentiometer option with potentiometer option	flying leads with or without connector cable with or without connector
Compliances standard optional	– CE, UKCA <sup>(1)(2)</sup>

(1) Actuators used in the EU must be in compliance with CE

(2) The 90 Vdc model cannot be delivered in compliance with CE.

## Optional Mechanical Features

Variety of front and rear adapters

Manual override

## Optional Electrical Features

Potentiometer feedback

## Accessories

Mechanical

Mounting pins

## Compatible Controls

Contact customer support at [www.thomsonlinear.com/cs](http://www.thomsonlinear.com/cs)

# Electrak GX DC – Technical Specifications

Mechanical Specifications		
Max. static load <sup>(1)</sup>	[N (lbf)]	
Dxx-xxA (acme screw)		11350 (2500)
Dxx-xxB (ball screw)		18000 (4000)
Max. dynamic load (Fx)	[N (lbf)]	
Dxxx-05A5		1100 (250)
Dxxx-10A5		2250 (500)
Dxxx-20A5		2250 (500)
Dxxx-05B5		2250 (500)
Dxxx-10B5		4500 (1000)
Dxxx-20B5		4500 (1000)
Dxxx-21B5		6800 (1500)
Dxxx-2KB5		9000 (2000)
Speed @ no load/max. load	[mm/s (in/s)]	
Dxxx-05A5		54/32 (2.10/1.20)
Dxxx-10A5		30/18 (1.20/0.70)
Dxxx-20A5		15/12 (0.67/0.45)
Dxxx-05B5		61/37 (2.40/1.40)
Dxxx-10B5		30/19 (1.30/0.80)
Dxxx-20B5		15/12 0.60/0.45)
Dxxx-21B5		15/11 (0.60/0.43)
Dxxx-2KB5		15/9 (0.60/0.40)
Min. ordering stroke (S) length	[in]	2
Max. ordering stroke (S) length <sup>(2)(3)(4)</sup>	[in]	24
Ordering stroke length increments	[in]	2
Operating temperature limits	[°C (F)]	-25 – 65 (-15 – 150)
Full load duty cycle @ 25 °C (77 °F)	[%]	25
End play, maximum	[mm (in)]	1.0 (0.04)
Restraining torque	[Nm (lbf-in)]	11.3 (100)
Protection class - static, standard (optional)		IP66 (IP66 & IP69K)
Salt spray resistance	[h]	96

(1) Max. static load at fully retracted stroke

(2) Max. ordering stroke length for Dxx-2KB5 is 12 inches

(3) Max. ordering stroke length for Dxx-21B5 is 20 inches

(4) For other strokes, contact customer support

Electrical Specifications		
Available input voltages <sup>(1)(2)</sup>	[Vdc]	12, 24, 36, 48, 90
Input voltage tolerance	[%]	± 10
Current draw @ no load/max. load	[A]	
D12x-05A5		12.0/33.0
D12x-10A5		8.0/27.0
D12x-20A5		3.0/15.0
D12x-05B5		8.0/28.0
D12x-10B5		5.0/27.0
D12x-20B5		3.0/13.0
D12x-21B5		3.0/20.0
D12x-2KB5		4.0/25.0
D24x-05A5		6.0/16.5
D24x-10A5		4.0/13.5
D24x-20A5		1.5/7.5
D24x-05B5		4.0/14.0
D24x-10B5		2.5/13.5
D24x-20B5		1.5/7.5
D24x-21B5		1.5/10.0
D24x-2KB5		2.0/12.5
D36x-05A5		4.0/11.0
D36x-10A5		2.67/9.0
D36x-20A5		1.0/5.1
D36x-05B5		2.67/9.3
D36x-10B5		1.67/9.0
D36x-20B5		1.0/5.1
D36x-21B5		1.0/6.7
D36x-2KB5		1.34/8.4
D48x-05A5		3.0/8.3
D48x-10A5		2.0/6.8
D48x-20A5		0.8/3.8
D48x-05B5		2.0/7.0
D48x-10B5		1.3/6.8
D48x-20B5		0.8/3.8
D48x-21B5		0.8/5.0
D48x-2KB5		1.0/6.3
D90x-05A5		1.5/4.1
D90x-10A5		1.0/3.4
D90x-20A5		0.4/1.9
D90x-05B5		1.0/3.5
D90x-10B5		0.6/3.4
D90x-20B5		0.4/1.9
D90x-21B5		0.4/2.5
D90x-2KB5		0.5/3.2
Flying leads length	[mm (in)]	165 (7.5)
Flying leads diameter	[mm (in)]	3 (0.12)
Flying leads cross section	[mm <sup>2</sup> (AWG)]	2 (14)
Cable length with option pot.	[mm (in)]	600 (24)
Cable diameter with option pot.	[mm (in)]	9 (0.35)
Cable leads cross section with option potentiometer	[mm <sup>2</sup> (AWG)]	
motor leads		2.5 (14)
potentiometer leads		1.5 (16)

(1) For other input voltages - contact customer support.

(2) 90 Vdc model not CE compliant.



# Electrak® GX DC – Dimensions

Dimensions	Projection
mm [inch]	

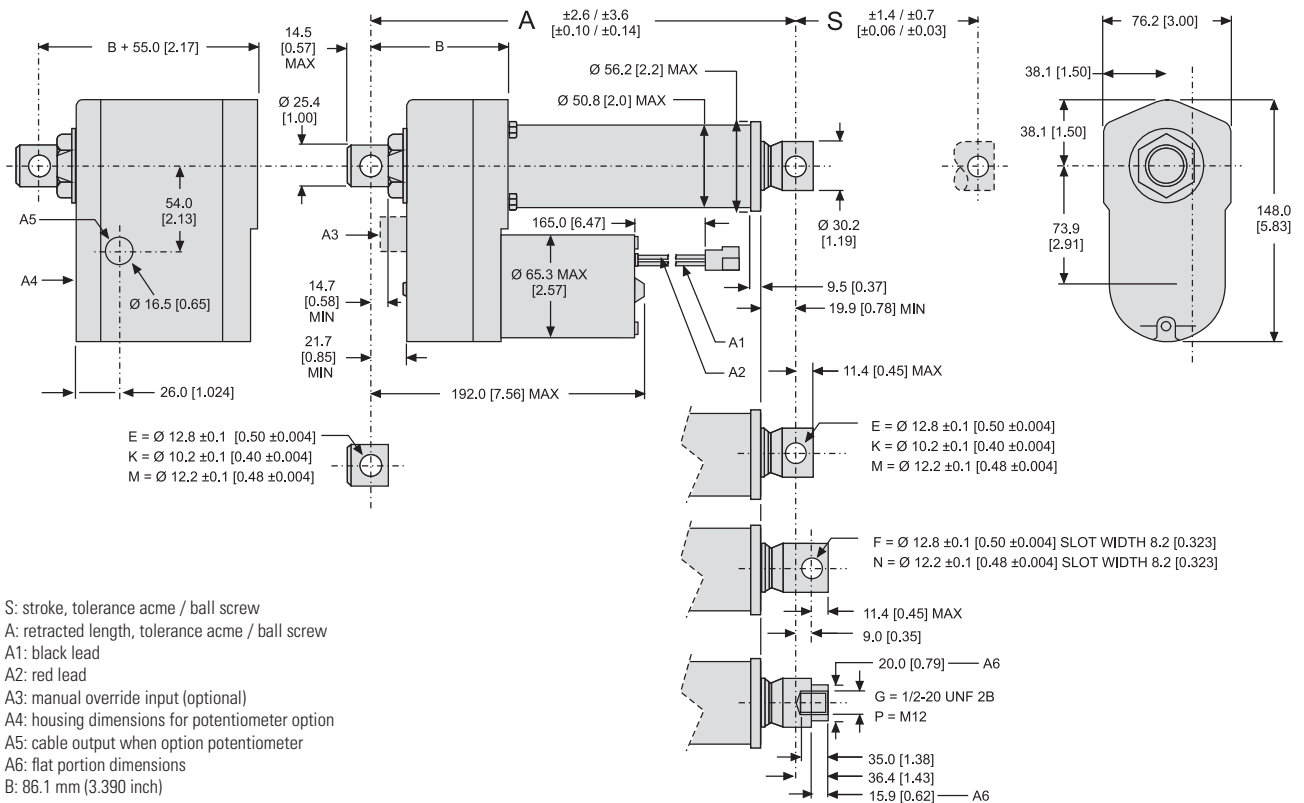

## Stroke, Retracted Length and Weight Relationships

Ordering stroke (S)	[in]	2	4	6	8	10	12	14	16	18	20	22	24
Retracted length, acme screw models (A)	[mm]	211.3	262.1	312.9	363.7	414.5	465.3	583.7	634.5	685.3	736.1	786.9	837.7
	[in]	8.32	10.32	12.32	14.32	16.32	18.32	22.98	24.98	26.98	28.98	30.98	32.98
Retracted length, ball screw models (A)	[mm]	251.5	302.3	353.1	403.9	454.7	505.5	623.6	674.4	725.2	776.0	826.8	877.6
	[in]	9.90	11.90	13.90	15.90	17.90	19.90	24.55	26.55	28.55	30.55	32.55	34.55
Add on length for option potentiometer	[mm]	55.0											
	[in]	2.17											
Weight, acme screw models	[kg]	4.4	4.6	4.8	5.0	5.1	5.3	5.5	5.6	5.8	5.9	6.1	6.2
	[lbs]	9.7	10.1	10.6	11.0	11.2	11.7	12.1	12.3	12.8	13.0	13.4	13.6
Weight, ball screw models	[kg]	5.0	5.2	5.4	5.6	5.8	6.0	6.1	6.2	6.4	6.5	6.7	6.9
	[lbs]	11.0	11.4	11.9	12.3	12.8	13.2	13.4	13.6	14.1	14.3	14.7	15.2
Add on weight for option potentiometer	[kg]	1.30											
	[lbs]	2.86											

# Electrak GX DC – Performance Diagrams

Load vs. Speed

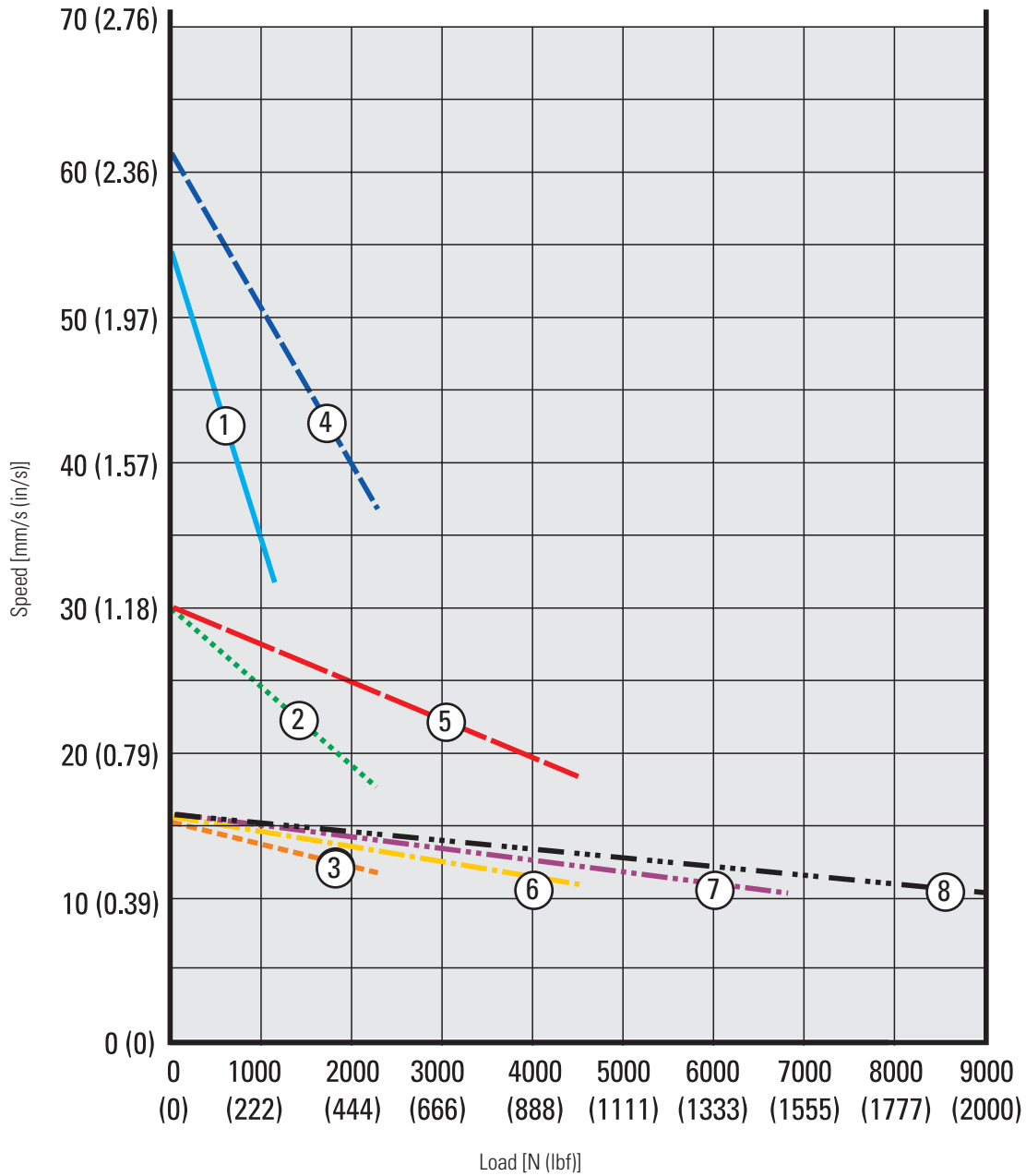

- 1. Dxxx-05A5 (1100 N (250 lbf)) —
- 2. Dxxx-10A5 (2250 N (500 lbf)) ⋯
- 3. Dxxx-20A5 (2250 N (500 lbf)) - - -
- 4. Dxxx-05B5 (2250 N (500 lbf)) - - - -
- 5. Dxxx-10B5 (4500 N (1000 lbf)) - - - -
- 6. Dxxx-20B5 (4500 N (1000 lbf)) - · - · -
- 7. Dxxx-21B5 (6800 N (1500 lbf)) - · - · -
- 8. Dxxx-2KB5 (9000 N (2000 lbf)) - · - · -



# Electrak® GX DC – Performance Diagrams

Load vs. Current for 12 and 24 Vdc actuators

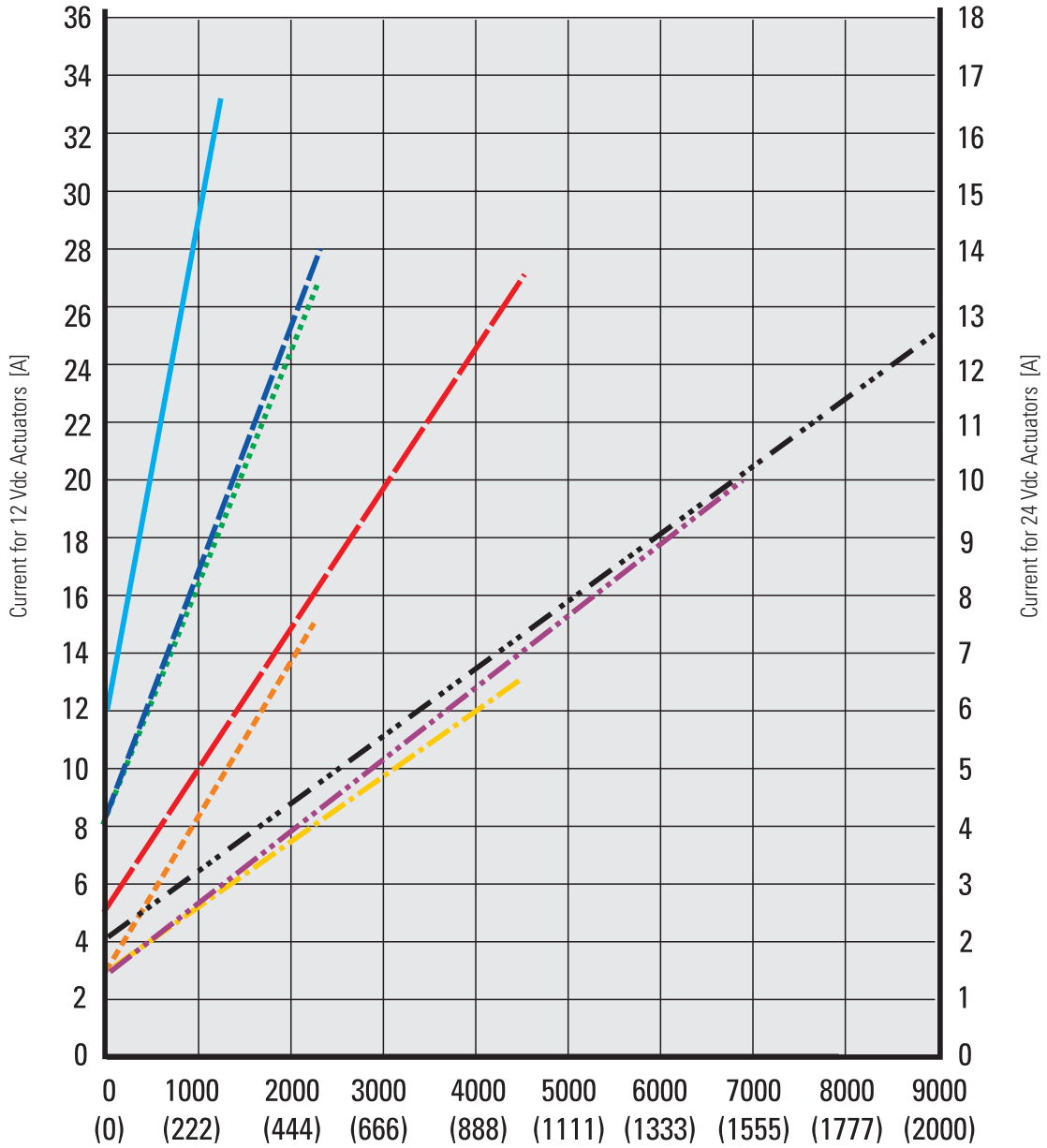

- |                              |  |                               |  |
|------------------------------|--|-------------------------------|--|
| Dxxx-05A5 (1100 N (250 lbf)) |  | Dxxx-10B5 (4500 N (1000 lbf)) |  |
| Dxxx-10A5 (2250 N (500 lbf)) |  | Dxxx-20B5 (4500 N (1000 lbf)) |  |
| Dxxx-20A5 (2250 N (500 lbf)) |  | Dxxx-21B5 (6800 N (1500 lbf)) |  |
| Dxxx-05B5 (2250 N (500 lbf)) |  | Dxxx-2KB5 (9000 N (2000 lbf)) |  |

Load vs. Current for 36 and 48 Vdc actuators

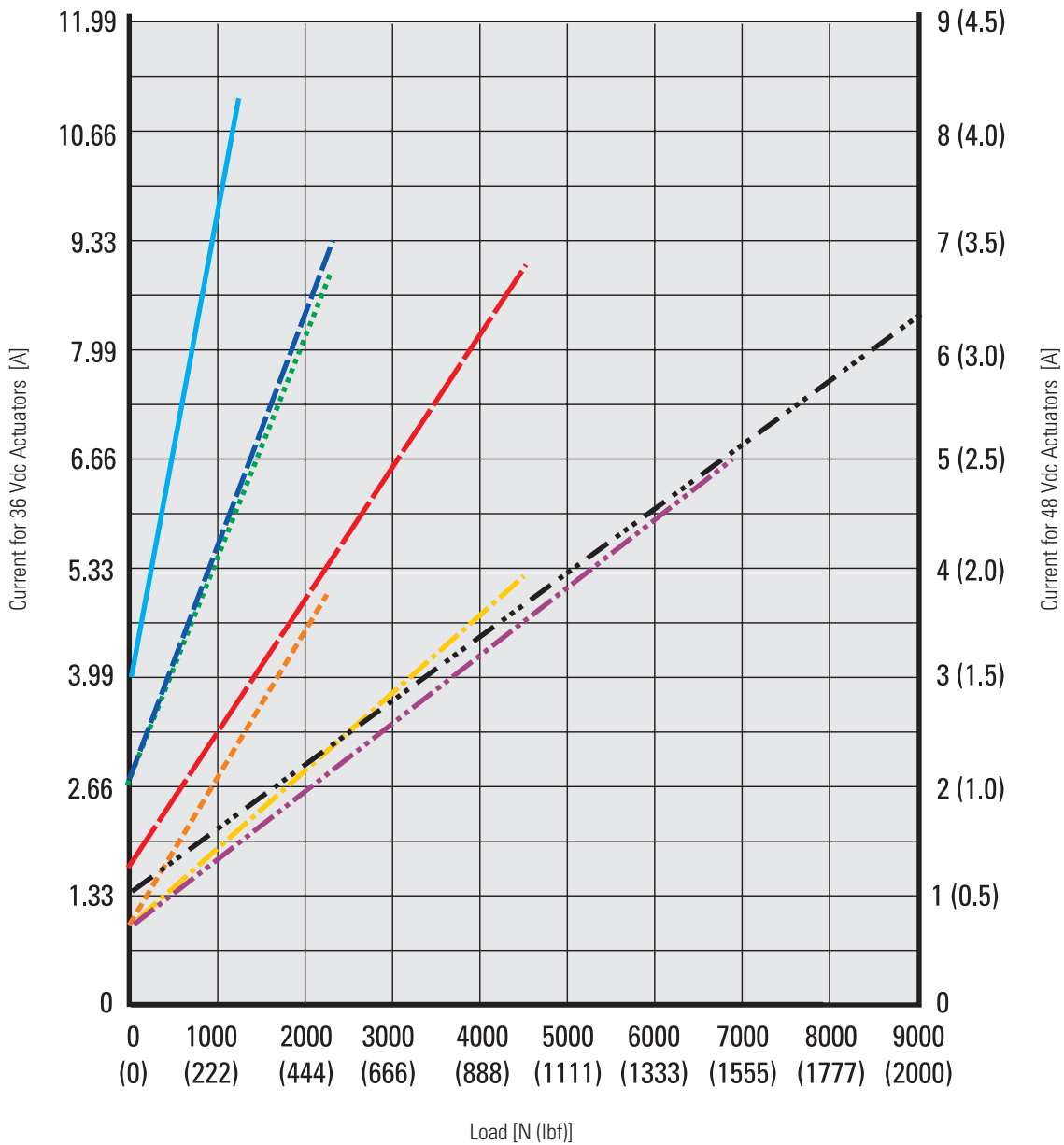

- |                              |  |                               |  |
|------------------------------|--|-------------------------------|--|
| Dxxx-05A5 (1100 N (250 lbf)) |  | Dxxx-10B5 (4500 N (1000 lbf)) |  |
| Dxxx-10A5 (2250 N (500 lbf)) |  | Dxxx-20B5 (4500 N (1000 lbf)) |  |
| Dxxx-20A5 (2250 N (500 lbf)) |  | Dxxx-21B5 (6800 N (1500 lbf)) |  |
| Dxxx-05B5 (2250 N (500 lbf)) |  | Dxxx-2KB5 (9000 N (2000 lbf)) |  |

# Electrak® GX DC – Ordering Key

## Ordering Key

1	2	3	4	5	6	7	8	9
<b>D12C</b>	<b>05A5-</b>	<b>02</b>	<b>M0</b>	<b>N</b>	<b>N</b>	<b>-D</b>	<b>E</b>	<b>E</b>

### 1. Model, input voltage and CE compliance

D12C = Electrak GX, 12 Vdc, CE compliant  
 D24C = Electrak GX, 24 Vdc, CE compliant  
 D36C = Electrak GX, 36 Vdc, CE compliant  
 D48C = Electrak GX, 48 Vdc, CE compliant  
 D12N = Electrak GX, 12 Vdc, not CE compliant  
 D24N = Electrak GX, 24 Vdc, not CE compliant  
 D36N = Electrak GX, 36 Vdc, not CE compliant  
 D48N = Electrak GX, 48 Vdc, not CE compliant  
 D90N = Electrak GX, 90 Vdc, not CE compliant

### 2. Dynamic load capacity, screw type and maximum speed

05A5 - = 1100 N, acme, 54 mm/s  
 10A5 - = 2250 N, acme, 30 mm/s  
 20A5 - = 2250 N, acme, 15 mm/s  
 05B5 - = 2250 N, ball, 61 mm/s  
 10B5 - = 4500 N, ball, 30 mm/s  
 20B5 - = 4500 N, ball, 15 mm/s  
 21B5 - = 6800 N, ball, 15 mm/s <sup>(1)</sup>  
 2KB5 - = 9000 N, ball, 9 mm/s <sup>(2)</sup>

### 3. Ordering stroke length

02 = 2 inch (50.8 mm)  
 04 = 4 inch (101.6 mm)  
 06 = 6 inch (152.4 mm)  
 08 = 8 inch (203.2 mm)  
 10 = 10 inch (254.0 mm)  
 12 = 12 inch (304.8 mm)  
 14 = 14 inch (355.6 mm)  
 16 = 16 inch (406.4 mm)  
 18 = 18 inch (457.2 mm)  
 20 = 20 inch (508.0 mm)  
 22 = 22 inch (558.8 mm)  
 24 = 24 inch (609.6 mm)

### 4. Rear adapter hole orientation

M0 = adapter at 0° (standard)  
 M3 = adapter at 90° <sup>(3)</sup>

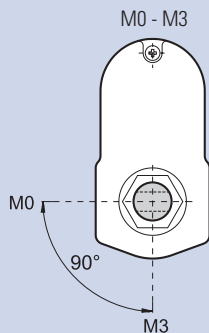

### 5. Ingress protection rating

N = IP66  
 K = IP66 and IP69K

### 6. Options

N = no option  
 P = potentiometer feedback  
 H = manual override

Dimensions for manual override option

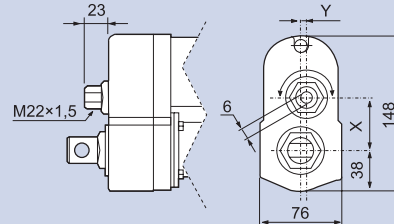

Model	X	Y
Dxxx05A(B)5-	49.6	0.0
Dxxx10A(B)5-	43.3	5.2
Dxxx20(21, 2K)A(B)5-	38.9	0.0

### 7. Connector option

-A = AMP terminal 42098-2, house 180908-5  
 -B = Packard Electric 56 Series  
 -D = no connector (flying leads)

### 8. Front adapter option

E = cross hole for 0.5 inch pin  
 F = forked cross hole for 0.5 inch pin  
 G = 1/2-20 UNF 2B female thread  
 K = cross hole for 10 mm pin  
 M = cross hole for 12 mm pin  
 N = forked cross hole for 12 mm pin  
 P = M12 female thread

### 9. Rear adapter option

E = cross hole for 0.5 inch pin  
 K = cross hole for 10 mm pin  
 M = cross hole for 12 mm pin

(1) 21B5 not possible with strokes above 20 inch

(2) 2KB5 not possible for strokes above 12 inch

(3) Not possible with option manual override

# Electrak GX DC – Electrical Connections

## Without Option

Actuator supply voltage	[Vdc]	
D12x		12
D24x		24
D36x		36
D48x		48
D90N		90

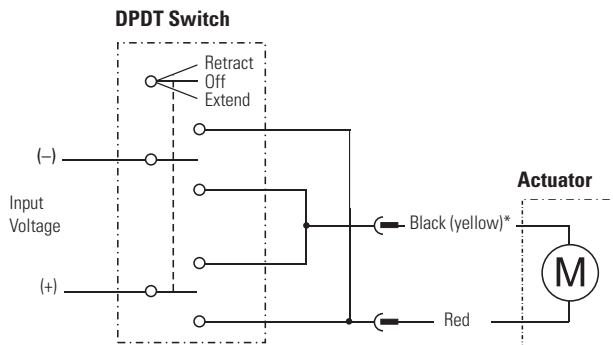

\* Lead can be black or yellow

Connect the red lead to positive and black (yellow)\* to negative to extend the actuator. Change polarity to retract the actuator.

## Option Potentiometer

Actuator supply voltage	[Vdc]	
D12x		12
D24x		24
D36x		36
D48x		48
D90N		90

Potentiometer type		wirewound
Potentiometer max. input voltage	[Vdc]	32
Potentiometer max. power	[W]	2
Potentiometer linearity	[%]	± 0.25
Potentiometer output resolution	[ohm/mm]	
2 - 10 inch stroke		39
11 - 20 inch stroke		20
21 - 24 inch stroke		10

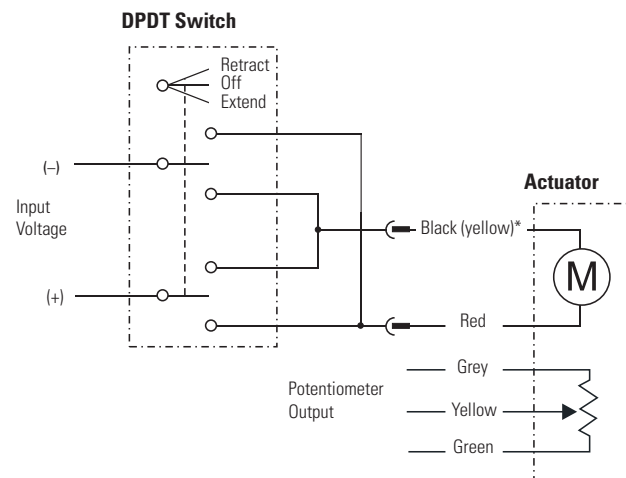

\* Lead can be black or yellow

Connect the red lead to positive and black (yellow)\* to negative to extend the actuator. Change polarity to retract the actuator. The potentiometer output cable has 0 ohm between grey and yellow leads when the actuator is fully extended.



## Electrak® GX DC – Accessories

### Mounting Pin Kits

Designation	A [mm(in)]	Part Number
Mounting pins (pair)	12.7 (0.5)	D603 028

The mounting pins are used in the rear and front adapter holes of the actuator. The pins have a groove in each end so that it can be secured with snap rings.

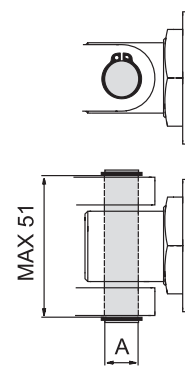

Dimensions

mm

### Mating Connectors

Designation	Part Number
North American mating connector kit	9100-448-001
Rest of the world mating connector kit	LA100B9P1

The mating connector kit consist of the necessary connector parts required to be able to connect to the connector on the actuator wires.

# Notes