



DMHD – Technical Features



Powered by the **Electrak® HD**

Standard Features

- Self-supporting column in extruded anodized aluminium with high load torque capability
- Onboard electronics with many optional functions
- 12 or 24 Vdc as standard input voltages
- Static load up to 18 kN (4050 lbf)
- Dynamic load up to 16 kN (3584 lbf)
- Stroke up to 600 mm
- Speed up to 71 mm/s (2.8 in/s)
- Protection class static IP65
- T-slot grooves along the entire profile
- Maintenance free

General Specifications

Screw type	ball
Nut type	load lock ball nut
Manual override	no
Anti-rotation	yes
Static load holding brake	yes
Safety features	Electrak monitoring package: current monitoring voltage monitoring temperature monitoring load trip point calibration internal end-of-stroke limit switches ⁽¹⁾ end-of-stroke dynamic braking
Electrical connections	cable with flying leads
Compliances	CE

Optional Electronic Control Features

CANopen CAN bus
SAE J1939 CAN bus
Synchronization option
Low-level switching
Programmable limit switches
Signal-follower
End-of-stroke indication output
Analog position output
Digital position output

Control Option Combinations

EXX	Electrak Monitoring Package only
ELX	EXX + End-of-Stroke Indication Output
EXP	EXX + Analog Position Output
EXD	EXX + Digital Position Output
ELP	ELX + Analog Position Output
ELD	ELX + Digital Position Output
LXX	EXX + Low-Level Signal Motor Switching
LLX	EXX + LXX + End-of-Stroke Indication Output
LXP	EXX + LXX + Analog Position Output
LPS	EXX + LXX + Programmable Limit Switches + Signal-Follower
CNO	SAE J1939 CAN Bus Control + Open-Loop Speed Control
COO	CANopen CAN Bus Control + Open-Loop Speed Control
SY2	Synchronization Option

Accessories

T-slot bolts

Compatible Controls

Contact customer support at www.thomsonlinear.com/cs

(1) Dynamic braking is included at the ends of stroke for all DMHD actuators. Dynamic braking offered throughout the entire stroke length only on low-level switching and J1939 options.

DMHD – Technical Specifications

Mechanical Specifications		
Max. static load ⁽¹⁾	[kN (lbf)]	18 (4050)
Max. dynamic load (Fx)	[kN (lbf)]	
DMHDxxB017		1.7 (382)
DMHDxxB026		2.6 (585)
DMHDxxB045		4.5 (1012)
DMHDxxB068		6.8 (1529)
DMHDxxB100		10 (2248)
DMHDxxB160		16 (3584)
Max. load torque, dyn. and static	[Nm (lbf-in)]	710 (6284)
Speed @ no load/max. load ⁽²⁾	[mm/s (in/s)]	
DMHDxxB017		71/58 (2.8/2.28)
DMHDxxB026		40/32 (1.6/1.3)
DMHDxxB045		24/19 (0.94/0.75)
DMHDxxB068		18/14 (0.71/0.55)
DMHDxxB100		11/9 (0.43/0.35)
DMHDxxB160		7/5 (0.27/0.21)
Min. ordering stroke (S) length	[mm]	100
Max. ordering stroke (S) length ⁽³⁾	[mm]	600
Ordering stroke length increments	[mm]	50
Operating temperature limits	[°C (F)]	-40 – 85 (-40 – 185)
Full load duty cycle @ 25 °C (77 °F)	[%]	25 ⁽⁴⁾
End play, maximum	[mm (in)]	1.2 (0.047)
Protection class - static		IP65

¹ Max. static load at fully retracted stroke.

² For units with the synchronization option, the speed will vary slightly when synchronizing, but will typically remain close to the speed they are rated for at full load. See page 90 for more information on the synchronization option.

³ 500 mm max. for 16 kN

⁴ For DMHDxx-B100 and DMHDxx-160, unidirectional load, the duty cycle is 15%.

⁵ Do not use PWM voltage for speed control to avoid damaging the onboard electronics.

Electrical Specifications		
Available input voltages ⁽⁵⁾	[Vdc]	12, 24
Input voltage tolerance	[Vdc]	
DMHD12 (12 Vdc input voltage)		9 - 16
DMHD24 (24 Vdc input voltage)		18 - 32
Current draw @ no load/max. load	[A]	
DMHD12B017		3/18
DMHD24B017		1.5/9
DMHD12B026		3/18
DMHD24B026		1.5/9
DMHD12B045		3/18
DMHD24B045		1.5/9
DMHD12B068		3/20
DMHD24B068		1.5/10
DMHD12B100		3/18
DMHD24B100		1.5/9
DMHD12B160		3/20
DMHD24B160		1.5/10
Motor leads cross section	[mm ² (AWG)]	2 (14)
Signal leads cross section	[mm ² (AWG)]	0.5 (20)
Standard cable lengths	[m (in)]	1.5, 5 (59, 197)
Cable diameter	[mm (in)]	7.5 (.295)
Flying lead length	[mm (in)]	76 (3)
Stripped lead length	[mm (in)]	6 (0.25)



DMHD – Dimensions

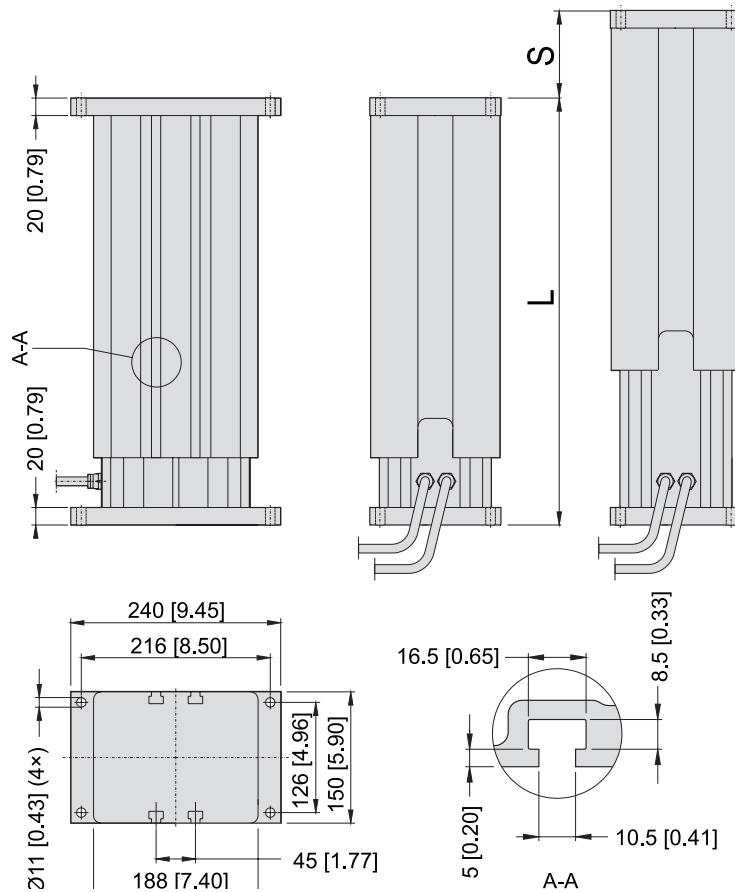

Dimensions	Projection
mm [inch]	

Note. All models have two cables except models with control option EXX which has one placed in the center of the profile.

Stroke, Retracted Length and Weight Relationships

Ordering stroke (S)	[mm]	100	150	200	250	300	350	400	450	500	550	600
Retracted length (A) for DMHDxxB017(026,045,068)	[mm]	357	407	457	507	557	657	707	757	807	857	907
	[in]	14.1	16.0	18.0	20.0	21.9	25.9	27.8	29.8	31.8	33.7	35.7
Weight for DMHDxxB017(026,045,068)	[kg]	21.8	23.3	24.9	26.4	28.0	30.8	32.3	33.8	35.5	37.0	38.5
	[lbs]	48.0	51.3	54.8	58.1	61.6	67.8	71.1	74.4	78.1	81.4	84.7
Retracted length (A) for DMHDxxB100	[mm]	407	457	507	557	607	657	707	757	807	857	907
	[in]	16.0	18.0	20.0	21.9	23.9	23.9	27.8	29.8	31.8	33.7	35.7
Weight for DMHDxxB100	[kg]	22.0	23.6	25.1	26.7	28.2	31.1	32.5	34.7	36.4	38.0	39.5
	[lbs]	48.4	51.9	55.2	58.7	62.0	68.4	71.5	76.3	80.1	83.6	86.9
Retracted length (A) for DMHDxxB160 *	[mm]	407	457	507	557	607	657	707	757	807	-	-
	[in]	16.0	18.0	20.0	21.9	23.9	23.9	27.8	29.8	31.8	-	-
Weight for DMHDxxB160 *	[kg]	22.3	23.9	25.4	27.0	28.5	31.4	32.5	34.7	36.4	-	-
	[lbs]	49.1	52.6	55.9	59.4	62.7	69.1	71.5	76.3	80.1	-	-

* Max. stroke for DMHDxxB160 (16 kN (3584 lbf)) is 500 mm.

DMHD – Performance Diagrams

Load vs. Speed ⁽¹⁾

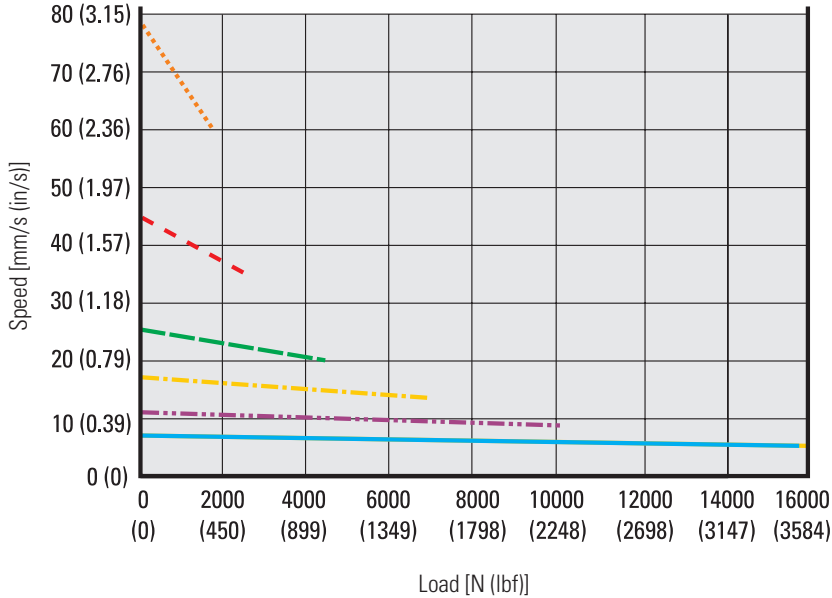

Off Center Load Capacity

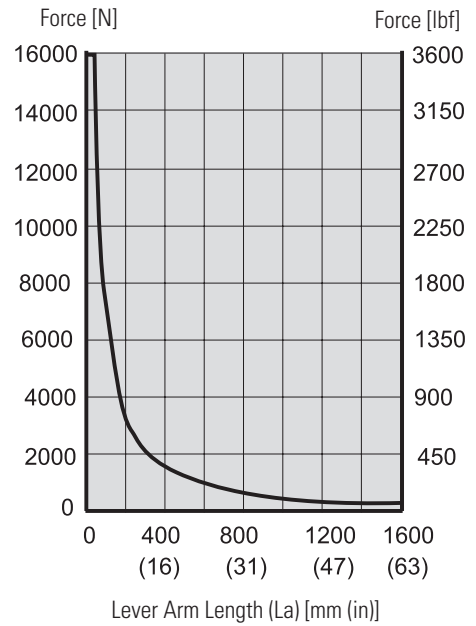

¹ Curves valid for all units except those with the synchronization option, where the speed at any load is 25% lower than for those without.

Load vs. Current

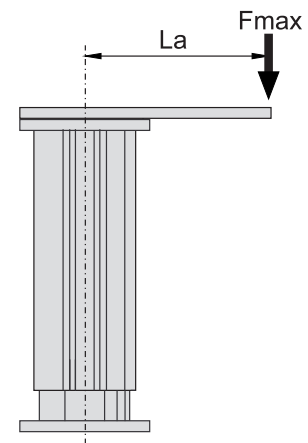
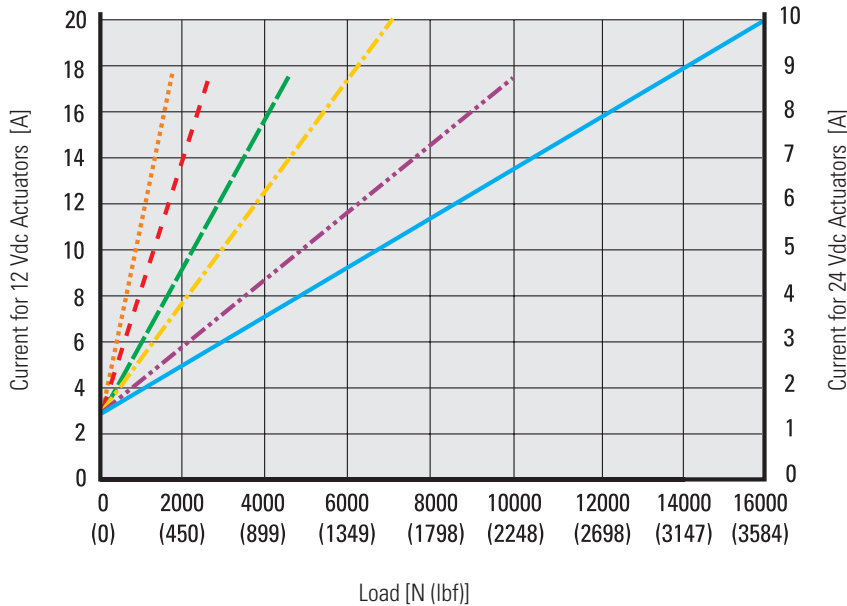

- DMHDxxB017 (1.7 kN (382 lbf)) - - - - - DMHDxxB045 (4.5 kN (1012 lbf)) - - - - - DMHDxxB100 (10 kN (2248 lbf)) - - - - -
- DMHDxxB026 (2.6 kN (585 lbf)) - - - - - DMHDxxB068 (6.8 kN (1529 lbf)) - - - - - DMHDxxB160 (16 kN (3584 lbf)) - - - - -

Note! Curves were generated at an ambient temperature of 21°C (70°F). Different ambient temperature and individual actuator characteristics can produce slightly different values.



DMHD – Ordering Key

Ordering Key				
1	2	3	4	5
DMHD12-	B026-	0300	LXX	5
<p>1. Model and input voltage DMHD12- = lifting column type DMHD, 12 Vdc DMHD24- = lifting column type DMHD, 24 Vdc</p> <p>2. Screw type, dynamic load capacity B017- = ball screw, 1.7 kN (382 lbf) B026- = ball screw, 2.6 kN (585 lbf) B045- = ball screw, 4.5 kN (1012 lbf) B068- = ball screw, 6.8 kN (1529 lbf) B100- = ball screw, 10 kN (2248 lbf) B160- = ball screw, 16 kN (3584 lbf)</p> <p>3. Ordering stroke length ⁽¹⁾ ⁽²⁾ 0100 = 100 mm 0150 = 150 mm 0200 = 200 mm 0250 = 250 mm 0300 = 300 mm 0350 = 350 mm 0400 = 400 mm 0450 = 450 mm 0500 = 500 mm 0550 = 550 mm 0600 = 600 mm</p>		<p>4. Electrak Modular Control System options EXX = Electronic Monitoring Package only ELX = EXX + end-of-stroke indication output EXP = EXX + analog (potentiometer) position output EXD = EXX + digital position output ELP = ELX + analog (potentiometer) position output ELD = ELX + digital position output LXX = EXX + low-level signal motor switching LLX = EXX + LXX + end-of-stroke indication output LXP = EXX + LXX + analog (potentiometer) position output LPS = EXX + LXX + programmable limit switches + signal-follower CNO = SAE J1939 CAN bus + open-loop speed control COO = CANopen CAN bus + open-loop speed control SY2 = LXX + Synchronization option</p> <p>5. Cable length and connection type 1 = 1.5 m long cable with flying leads 2 = 5.0 m long cable with flying leads</p> <p>(1) Other stroke lengths available upon request. Contact customer support (2) Max. stroke for DMHDxxB160 (16 kN (3584 lbf)) is 500 mm.</p>		

DMHD – Electrical Connections

Option Type EXX

Actuator supply voltage	[Vdc]	
DMHD12		12
DMHD24		24

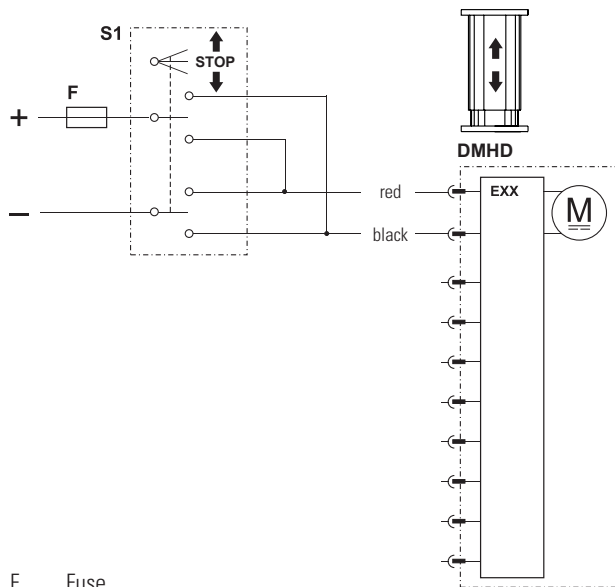

F Fuse
S1 Double pole double throw switch

Control option EXX contains Electrak Monitoring Package features, guaranteeing safe operation of the actuator and equipment. With control option EXX, the polarity of the motor voltage is switched by a customer-supplied switch (switch, relay, etc.) to make the actuator extend or retract. The switch, power supply, wiring and all other components must be able to handle the motor current for the actuator model and load being used, as well as the inrush current (up to three times the max. continuous current for the max. load being used for up to 150 milliseconds).

Option Type ELX

Actuator supply voltage	[Vdc]	
DMHD12		12
DMHD24		24
Output contact type		potential free
Limit switch max. switch voltage	[Vdc]	140
Limit switch max. switch current	[mA]	350
Limit switch max. switch power	[W]	5

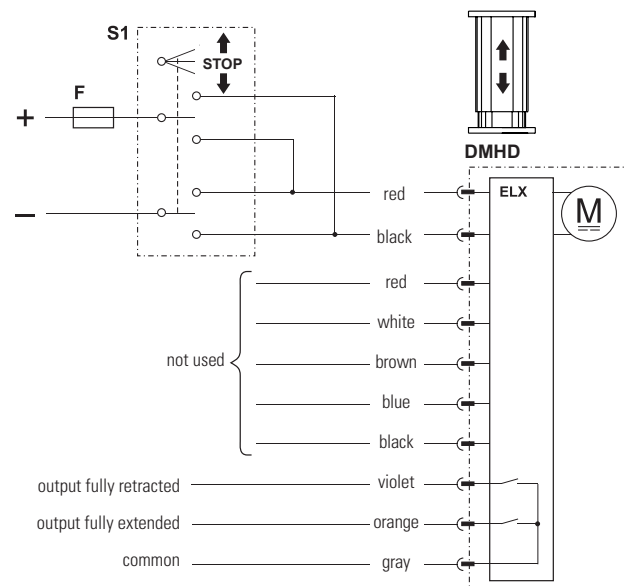

F Fuse
S1 Double pole double throw switch

Control option ELX works as option EXX but also has two outputs that indicate when the extension tube is in its fully extended or retracted position.

DMHD – Electrical Connections

Option Type EXP		
Actuator supply voltage	[Vdc]	
DMHD12		9 - 16
DMHD24		18 - 32
Potentiometer type		wire-wound
Potentiometer max. input voltage	[Vdc]	32
Potentiometer max. power	[W]	1
Potentiometer linearity	[%]	± 0.25
Potentiometer output resolution	[ohm/mm]	
50 - 100 mm stroke		65.6
150 - 250 mm stroke		32.8
300 - 500 mm stroke		19.7
550 - 600 mm stroke		9.8

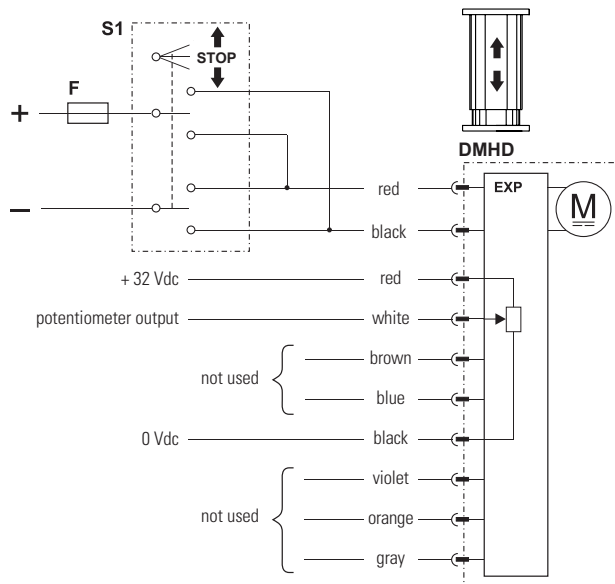

F Fuse
S1 Double pole double throw switch

Control option EXP works as option EXX but also has an analog (potentiometer) output that will provide feedback on the extension tube position.

Option Type EXD		
Actuator supply voltage	[Vdc]	
DMHD12		9 - 16
DMHD24		18 - 32
Encoder type		hall effect
Encoder input voltage	[Vdc]	4 - 24
Encoder output voltage levels	[Vdc]	
low (logical zero), typical / max.		0.1 / 0.25
Encoder resolution	[mm/pulse]	
DMHDxx-B017		0.28
DMHDxx-B026		0.15
DMHDxx-B045		0.09
DMHDxx-B068		0.07
DMHDxx-B100		0.04
DMHDxx-B160		0.03

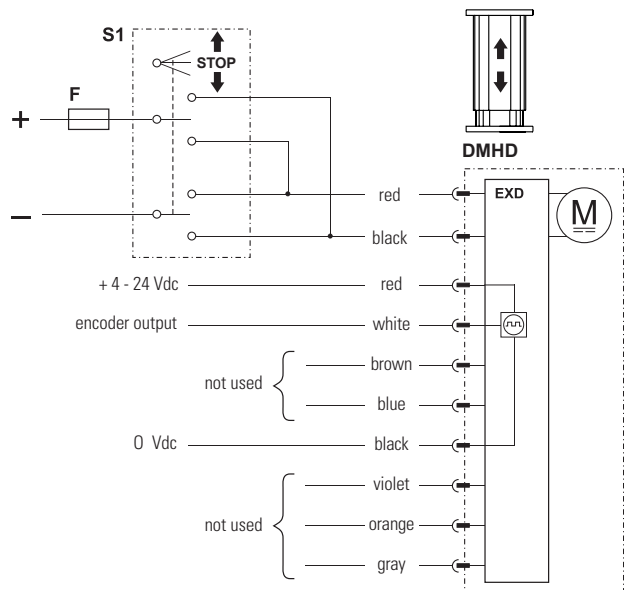

F Fuse
S1 Double pole double throw switch

Control option EXD works as option EXX but also has a single-channel encoder output that will provide feedback on the extension tube position.

Option Type ELP		
Actuator supply voltage DM HD12 DMHD24	[Vdc]	9 - 16 18 - 32
Output contact type		potential free
Max. output voltage	[Vdc]	140
Max. output current	[mA]	350
Max. output power	[W]	5
Potentiometer type		wire-wound
Potentiometer max. input voltage	[Vdc]	32
Potentiometer max. power	[W]	1
Potentiometer linearity	[%]	± 0.25
Potentiometer output resolution	[ohm/mm]	
50 - 100 mm stroke		65.6
150 - 250 mm stroke		32.8
300 - 500 mm stroke		19.7
550 - 600 mm stroke		9.8

Option Type ELD		
Actuator supply voltage DMHD12 DMHD24	[Vdc]	9 - 16 18 - 32
Output contact type		potential free
Max. output voltage	[Vdc]	140
Max. output current	[mA]	350
Max. output power	[W]	5
Encoder type		hall effect
Encoder input voltage	[Vdc]	4 - 24
Encoder output voltage levels low (logical zero), typical / max.	[Vdc]	0.1 / 0.25
Encoder resolution	[mm/pulse]	
DMHDxx-B017		0.28
DMHDxx-B026		0.15
DMHDxx-B045		0.09
DMHDxx-B068		0.07
DMHDxx-B100		0.04
DMHDxx-B160		0.03

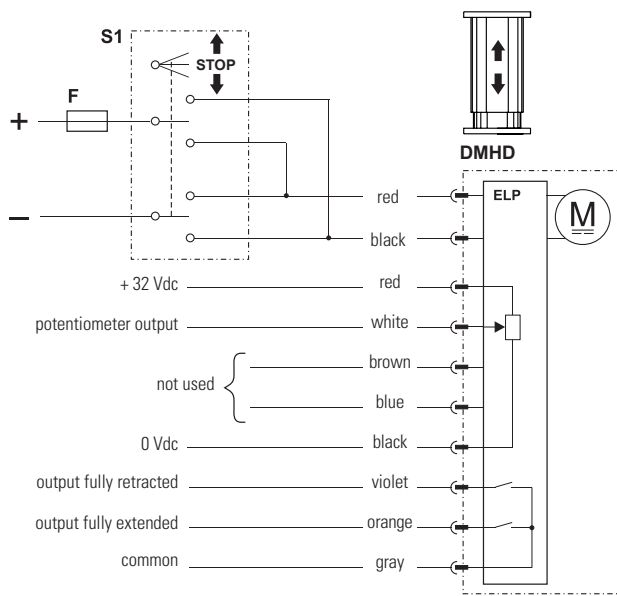

F Fuse
S1 Double pole double throw switch

Control option ELP works as option EXP but also has two outputs that indicate when the extension tube is in its fully extended or retracted position.

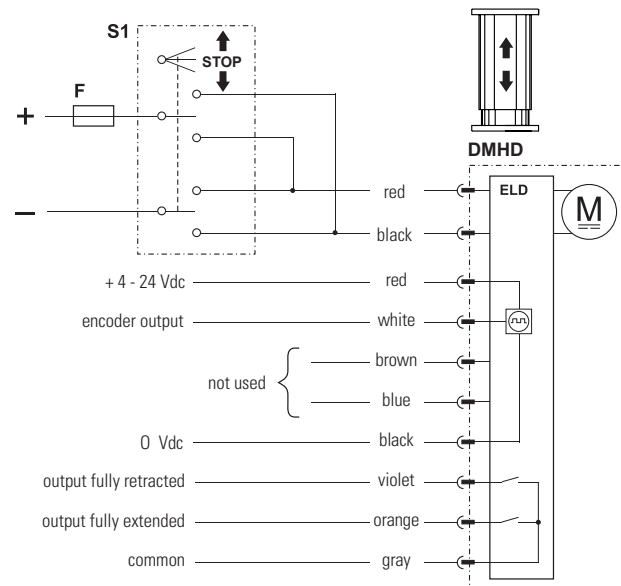

F Fuse
S1 Double pole double throw switch

Control option ELD works as option EXD but also has two outputs that indicate when the extension tube is in its fully extended or retracted position.

DMHD – Electrical Connections

Option Type LXX

Actuator supply voltage DMHD12 DMHD24	[Vdc]	9 - 16 18 - 32
Extend / retract input voltage	[Vdc]	9 - 32
Extend / retract input current	[mA]	6 - 22

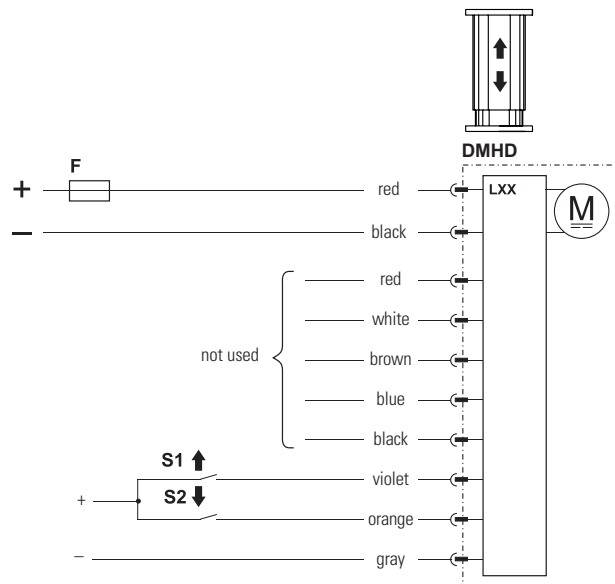

- F Fuse
- S1 Extend switch
- S2 Retract switch

Control option LXX has all the basic Electrak Monitoring Package features included in control option EXX, but the polarity of the motor voltage is switched by the onboard electronics instead. The customer-supplied switches used to command the actuator to extend or retract only need to handle low-level signals. However, the power supply and wiring that supply the actuator must be able to handle the motor current for the actuator model and load being used, as well as the inrush current (up to one and a half times the max. continuous current for the max. load being used for up to 150 milliseconds).

Option Type LLX

Actuator supply voltage DMHD12 DMHD24	[Vdc]	9 - 16 18 - 32
Output contact type		potential free
Max. switched output voltage	[Vdc]	140
Max. output current	[mA]	350
Max. output power	[W]	5
Extend / retract input voltage	[Vdc]	9 - 32
Extend / retract input current	[mA]	6 - 22

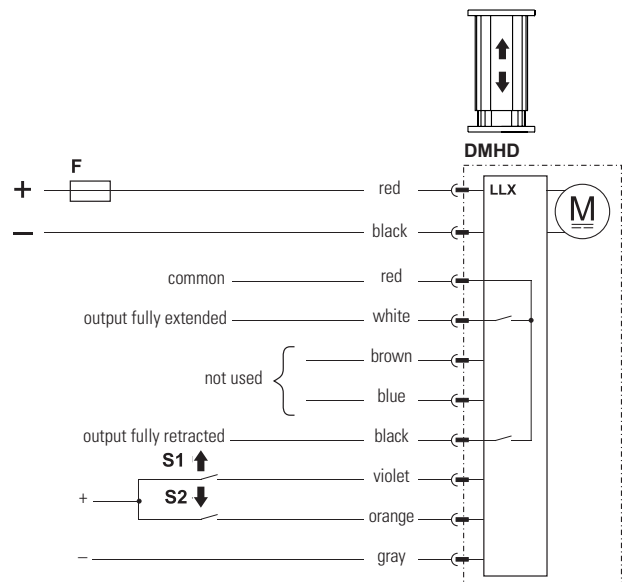

- F Fuse
- S1 Extend switch
- S2 Retract switch

Control option LLX works as option LXX but also has two outputs that indicate when the extension tube is in its fully extended or retracted position.

Option Type LXP		
Actuator supply voltage	[Vdc]	9 - 16 DMHD12 DMHD24 18 - 32
Potentiometer type		wire-wound
Potentiometer max. input voltage	[Vdc]	32
Potentiometer max. power	[W]	1
Potentiometer linearity	[%]	± 0.25
Potentiometer output resolution	[ohm/mm]	65.6 50 - 100 mm stroke 32.8 150 - 250 mm stroke 19.7 300 - 500 mm stroke 9.8 550 - 600 mm stroke
Extend / retract input voltage	[Vdc]	9 - 32
Extend / retract input current	[mA]	6 - 22

Option Type LPS		
Actuator supply voltage	[Vdc]	9 - 16 DMHD12 DMHD24 18 - 32
Signal-follower input voltage	[Vdc]	0.5 - 4.5
Signal-follower max. current	[A]	0.8
Signal-follower movement	[mm/Vdc]	
Signal-follower repeatability	[± mm]	0.1
Programming inputs voltage	[Vdc]	9 - 32
Extend / retract input voltage	[Vdc]	9 - 32
Extend / retract input current	[mA]	6 - 22

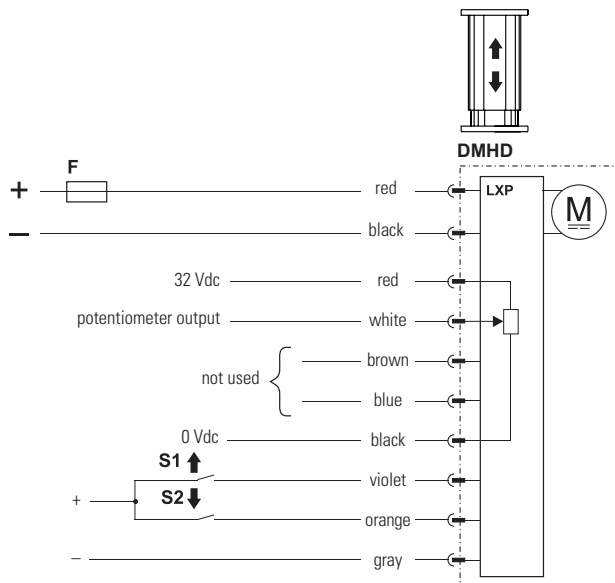

- F Fuse
- S1 Extend switch
- S2 Retract switch

Control option LXP works as option LXX but also has an analog (potentiometer) output that will provide feedback on the extension tube position.

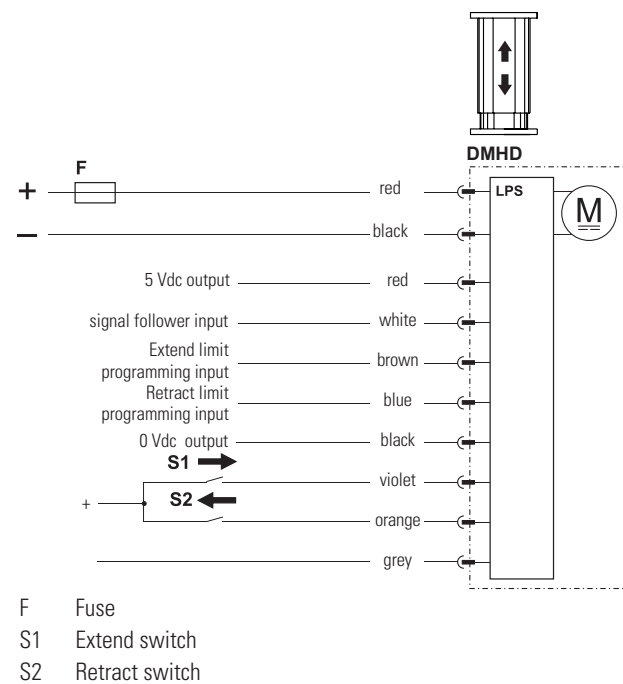

- F Fuse
- S1 Extend switch
- S2 Retract switch

Control option LPS works as option LXX but also has programmable mid stroke software extend and retract limits as well as a signal-follower input that allow the extension tube position to be controlled from a potentiometer or another voltage control.

DMHD – Electrical Connections

Option Type SY2		
Actuator supply voltage	[Vdc]	
DMHD12		9 - 16
DMHD24		18 - 32
Extend / retract input voltage	[Vdc]	9 - 32
Extend / retract input current	[mA]	6 - 22
Number of synchronized actuators		2 - 8
Max. actuator speed difference	[%]	25
Hold and wait distance	[mm]	
DMHDxx-B017		25.0
DMHDxx-B026		15.0
DMHDxx-B045		10.0
DMHDxx-B068		7.5
DMHDxx-B100		5.0
DMHDxx-B160		2.5

Control option SY2 works as option LXX but also has a synchronization feature, allowing up to eight actuators having the SY2 option to run in integrated motion. When using the low-level extend and retract inputs on the master actuator, the receiver(s) will follow. If there is a need to run an actuator individually, it is possible to put it into an override state by closing a switch (S3) connected to the red lead as shown in the wiring diagram.

Important Design Notes

- All actuators' supply voltages must be within $\pm 10\%$ of each other.
- While uneven loads can be supported, it is suggested that loads be distributed as evenly as possible to avoid overloading a single actuator within the system.
- The speed of the actuators will typically remain close to the speed they are rated for at full load, even if running at a lower load.
- If a unit detects that it is 1 mm further ahead of any other in the network, it will reduce its speed slightly to allow the other to catch up. If the positional difference between an actuator and the rearmost actuator exceeds the hold and wait distance specified in the table above, the unit will stop until the rearmost actuator catches up.
- If one actuator encounters an overload condition or detects that the measured position isn't updating while running the motor, it will trip the overload protection and send a signal to each actuator on the network to stop. The units can be immediately reversed (unless they bind up the system), or they can continue in the same direction after a power reset.
- Each actuator tracks the total number of actuators that are connected to the system. No synchronous motion will be allowed if any actuator detects that fewer than the minimum number of required actuators are connected. This allows the whole system to stop if the power or communication is lost to any actuator in the system.

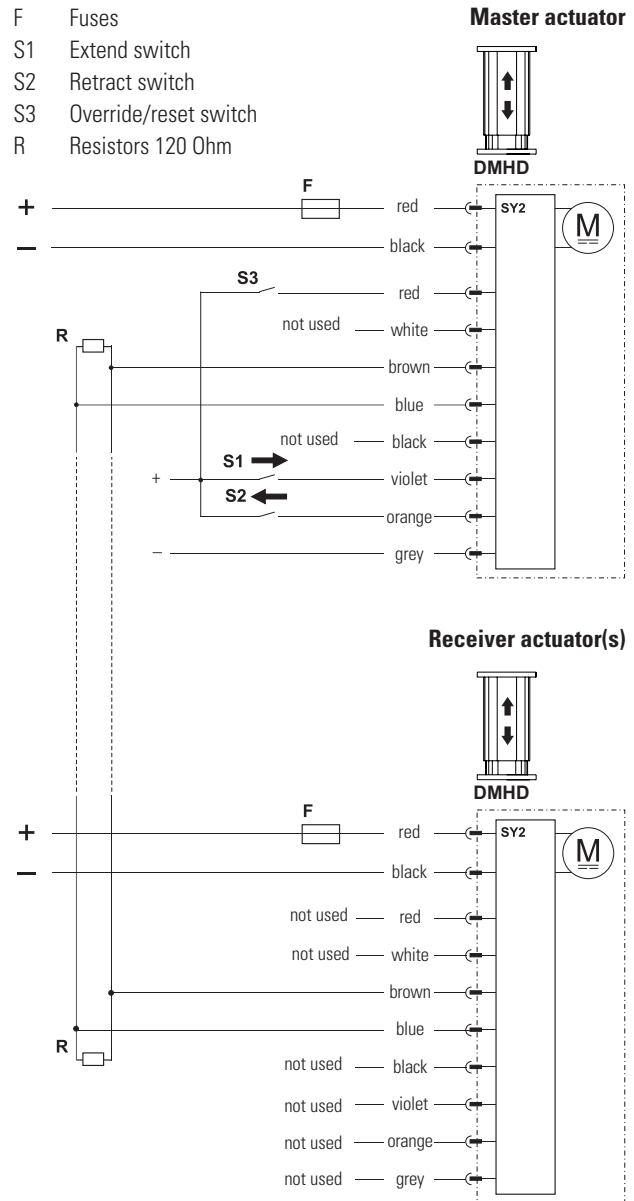

- Activating the override/reset signal on any of the actuators will reset the minimum number of required actuators that must be connected to the system to 0. If more actuators are connected at any point, the minimum number of required actuators will be updated to the number of actuators that are currently connected.
- In order to give the master and receiver(s) enough time to communicate, a 250 ms delay will be enforced following any motion and before any subsequent motion is allowed.

DMHD – Electrical Connections

DMHD – Accessories

Option Type CNO and COO

Actuator supply voltage [Vdc]	
DMHD12	9 - 16
DMHD24	18 - 32
Command data includes:	
<ul style="list-style-type: none"> • position • speed • current 	
Feedback data includes:	
<ul style="list-style-type: none"> • position • speed • current • other diagnostic information 	
Extend / retract input voltage [Vdc]	
DMHD12(24)	9 - 32
Extend / retract input current [mA]	
	6 - 22

T-slot Bolt

Designation	Part Number
M10 T-slot bolt	D800041

The T-slot bolt fits in to the T-slot running along the outer profile of the lifting column. The T-slot bolts can be used to mount the unit instead of using the upper mounting plate, or/and for attaching other components to the profile.

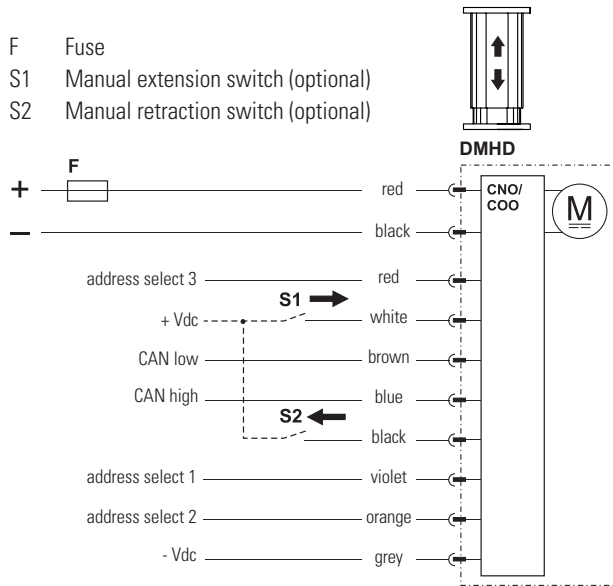
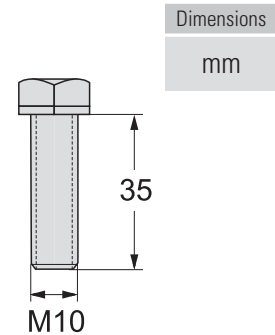

Control option CNO has a SAE J1939 CAN bus control interface and COO a CANopen interface to control and monitor the actuator. Extend and retract commands are sent via CAN messages on the CAN low and CAN high pins. Address select 1, 2 and 3 pins can be used as a binary encoded decimal (BCD) address to the default address. This can be used when multiple actuators are located on a single bus. The actuator can be manually forced to extend or retract by using the inputs on white and black wires. When the manual control inputs are used, CAN bus messages are ignored, but the unit will still provide CAN bus feedback messages. When the inputs are left floating, CAN bus functionality for control messages is restored.