



DMA – Technical Features



Standard Features

- Self-supporting column in extruded anodized aluminium with high load torque capability
- 1 × 230 Vac standard input voltage
- Static load up to 18 kN (4000 lbf)
- Dynamic load up to 9 kN (2000 lbf)
- Stroke up to 24 inch
- Speed up to 71 mm/s (2.8 in/s)
- Protection class static IP45
- Rugged, robust and strong
- T-slot grooves along the entire profile
- Maintenance free

General Specifications

Screw type	acme or ball
Nut type DMDxx-xxA (acme screw) DMDxx-xxB (ball screw)	self-locking lead nut load lock ball nut
Manual override	no
Anti-rotation	yes
Static load holding brake acme screw ball screw	no (self-locking) yes
Safety features	overload clutch auto reset thermal switch
Electrical connections	cable with flying leads
Compliances	CE

Accessories

T-slot bolts

Compatible Controls

Contact customer support at www.thomsonlinear.com/cs

DMA – Technical Specifications

Mechanical Specifications		
Max. static load ⁽¹⁾	[N (lbf)]	
DMA22xxA (acme screw)		11350 (2500)
DMA22xxB (ball screw)		18000 (4000)
Max. dynamic load (Fx)	[N (lbf)]	
DMA2205A5		1100 (250)
DMA2210A5		2250 (500)
DMA2220A5		2250 (500)
DMA2205B5		2250 (500)
DMA2210B5		4500 (1000)
DMA2220B5		4500 (1000)
DMA2221B5		6800 (1500)
Max. load torque, dyn. and static	[Nm (lbf-in)]	
DMAxxxxA (acme screw)		565 (5000)
DMAxxxxB (ball screw)		710 (6284)
Speed @ no load/max. load	[mm/s (in/s)]	
DMA2205A5		54/32 (2.10/1.20)
DMA2210A5		30/18 (1.20/0.70)
DMA2220A5		15/12 (0.67/0.45)
DMA2205B5		61/37 (2.40/1.40)
DMA2210B5		30/19 (1.30/0.80)
DMA2220B5		15/12 (0.60/0.45)
DMA2221B5		15/11 (0.60/0.43)
Min. ordering stroke (S) length	[in]	4
Max. ordering stroke (S) length	[in]	24
Ordering stroke length increments	[in]	2
Operating temperature limits	[°C (F)]	-25 – 65 (-15 – 150)
Max. on time	[s]	45
Full load duty cycle @ 25 °C (77 °F)	[%]	25
End play, maximum	[mm (in)]	1.0 (0.04)
Protection class - static, standard (optional)		IP45

(1) Max. static load at fully retracted stroke.

Electrical Specifications		
Available input voltages	[Vac]	1 × 230 ⁽¹⁾
Input voltage tolerance	[%]	± 10
Current draw @ no load/max. load	[A]	
DMA2205A5		1.10/1.55
DMA2210A5		0.85/1.30
DMA2220A5		0.95/1.25
DMA2205B5		0.85/1.30
DMA2210B5		0.85/1.30
DMA2220B5		0.85/1.30
DMA2221B5		0.85/1.25
Cable length	[mm (in)]	0.6 (24)
Cable diameter	[mm (in)]	9 (0.35)
Cable leads cross section	[mm ² (AWG)]	2.5 (14)

(1) Capacitor 10 µF (p/n 9200-448-003) required to run the actuator.



DMA – Dimensions

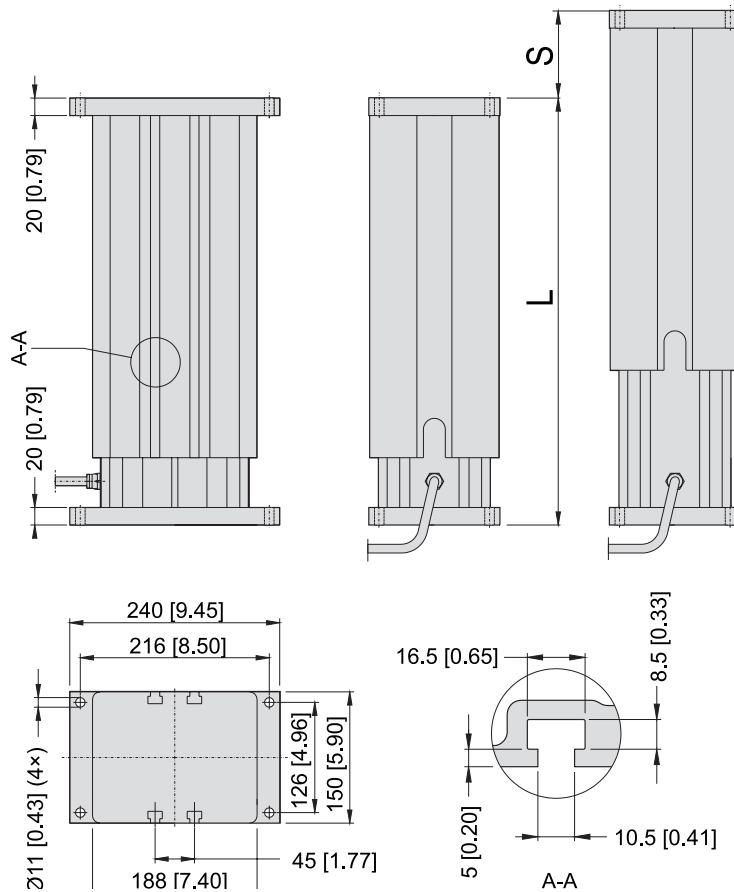

Dimensions	Projection
mm [inch]	

Stroke, Retracted Length and Weight Relationships

Ordering stroke (S)	[in]	4	6	8	10	12	14	16	18	20	24
Retracted length, acme screw models (A)	[mm]	329.6	380.4	431.2	482.0	532.8	633.6	684.4	735.2	786.0	887.6
	[in]	13.0	15.0	17.0	19.0	21.0	24.9	26.9	28.9	30.9	34.9
Retracted length, ball screw models (A)	[mm]	369.6	420.4	471.2	522.0	572.8	673.6	724.4	775.2	826.2	927.6
	[in]	14.6	16.6	18.6	20.6	22.6	26.5	28.5	30.5	32.5	36.5
Weight, acme screw models	[kg]	20.9	22.4	23.8	25.3	26.8	29.5	30.9	32.4	33.9	36.8
	[lbs]	46.1	49.4	52.5	55.8	59.1	65.0	68.1	71.4	74.7	81.1
Weight, ball screw models	[kg]	22.6	24.1	25.6	27.0	28.5	31.2	32.6	34.1	35.6	38.6
	[lbs]	49.8	53.1	56.4	59.5	62.8	68.8	71.9	75.2	78.5	85.1

DMA – Performance Diagrams

Speed and Current vs. Load - Diagram 1

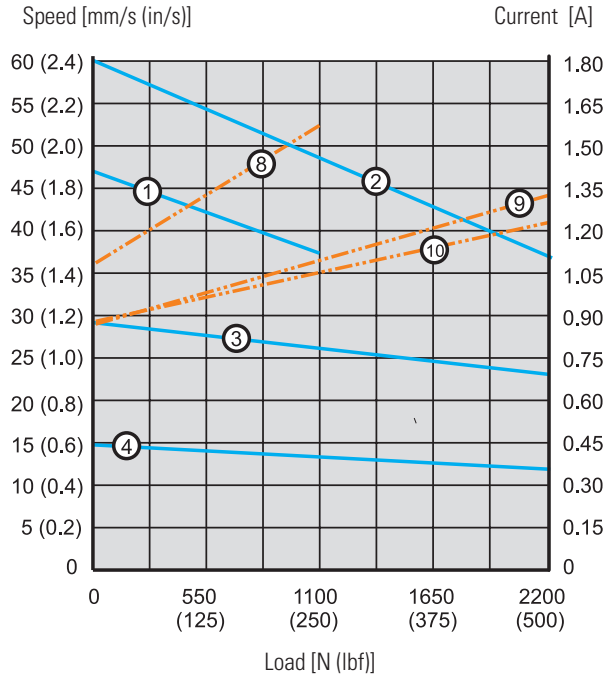

Speed and Current vs. Load - Diagram 2

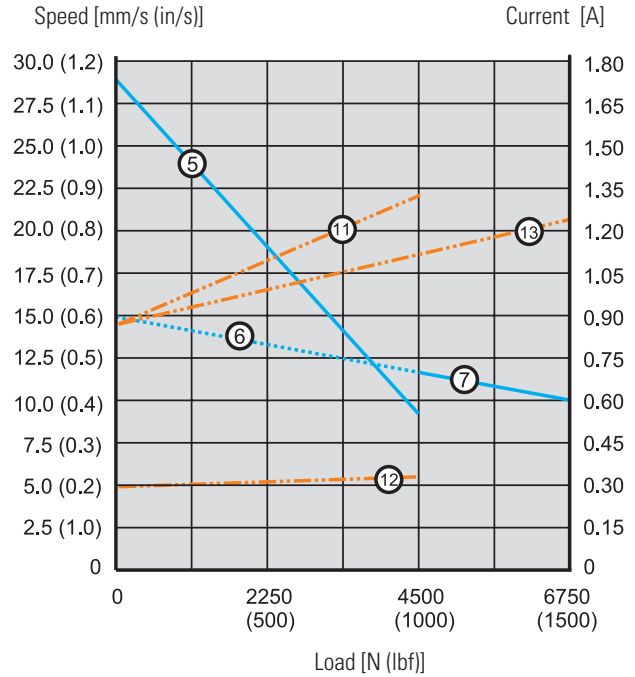

Speed Curves Diagram 1

- 1: DMA2205A5
- 2: DMA2205B5
- 3: DMA2210A5
- 4: DMA2220A5

Current Curves Diagram 1

- 8: DMA2205A5
- 9: DMA2205B5(10A5)
- 10: DMA2220A5

Speed Curves Diagram 2

- 5: DMA2210B5
- 6: DMA2220B5
- 7: DMA2221B5

Current Curves Diagram 2

- 11: DMA2210B5(20B5)
- 12: DMA2220B5
- 13: DMA2221B5

Off Center Load Capacity

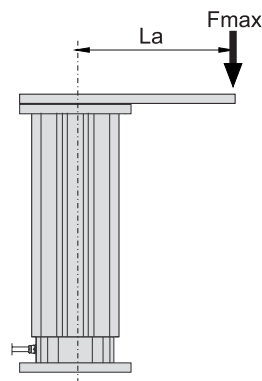
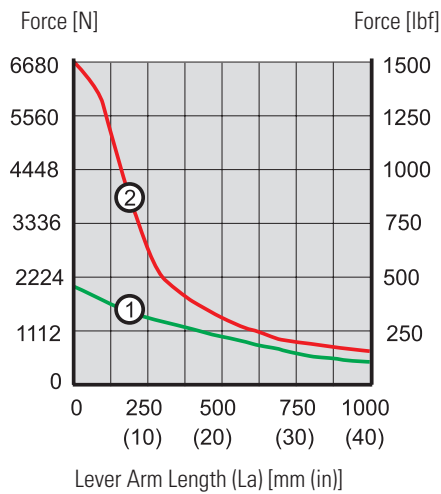

- 1: Acme screw models
- 2: Ball screw models



DMA – Ordering Key

Ordering Key		
1	2	3
DMA22	05A5-	10
1. Model and input voltage DMA22 = lifting column type DMA, 1 × 230 Vac		3. Ordering stroke length ⁽¹⁾ 04 = 4 inch (101.6 mm) 06 = 6 inch (152.4 mm) 08 = 8 inch (203.2 mm) 10 = 10 inch (254.0 mm) 12 = 12 inch (304.8 mm) 14 = 14 inch (355.6 mm) 16 = 16 inch (406.4 mm) 18 = 18 inch (457.2 mm) 20 = 20 inch (508.0 mm) 24 = 24 inch (609.6 mm)
2. Screw type, dynamic load capacity 05A5 - = 1100 N, acme, 54 mm/s 10A5 - = 2250 N, acme, 30 mm/s 20A5 - = 2250 N, acme, 15 mm/s 05B5 - = 2250 N, ball, 61 mm/s 10B5 - = 4500 N, ball, 30 mm/s 20B5 - = 4500 N, ball, 15 mm/s 21B5 - = 6800 N, ball, 15 mm/s		(1) Other stroke lengths available upon request. Please contact customer support. (2) Leave position blank for no option.

DMA – Accessories

T-Slot Bolt	
Designation	Part Number
M10 T-slot bolt	D800041

The T-slot bolt fits in to the T-slot running along the outer profile of the lifting column. The T-slot bolts can be used to mount the unit instead of using the upper mounting plate, or/and for attaching other components to the profile.

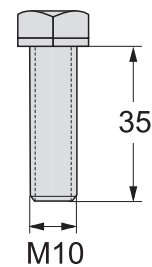

Dimensions
mm

DMA – Electrical Connections

Input Voltage 230 Vac

Actuator supply voltage DMA22	[Vac]	1 × 230
----------------------------------	-------	---------

Acme screw models (no anti-coast brake)

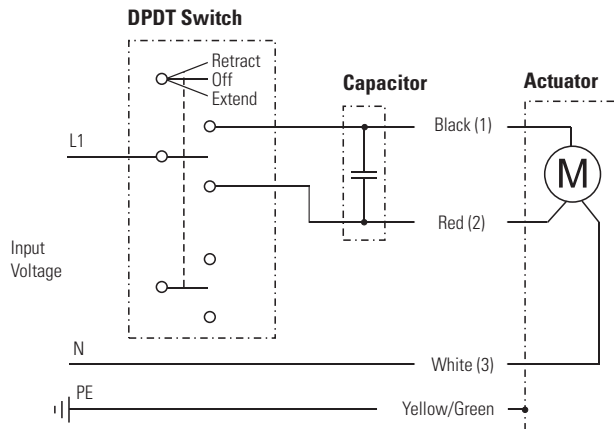

Ball screw models (with anti-coast brake)

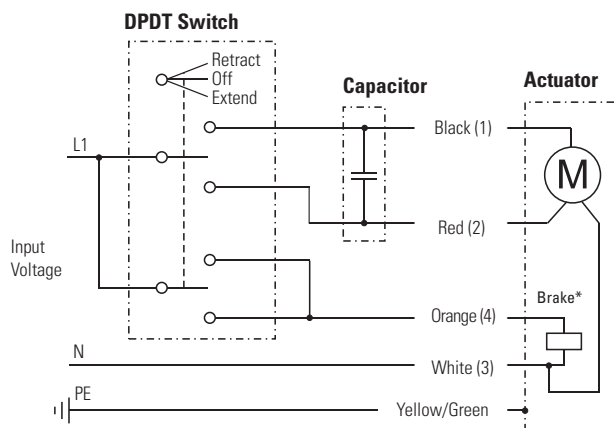

Leads can be either color or number marked. To be able to run the actuator, a 10 μF capacitor must be connected between black (1) and red (2) leads. See page 54 for ordering of capacitors. Connect black (1) lead to L1 and white (3) lead to N (neutral) to retract the actuator. Change L1 from lead black (1) to lead red (2) to extend the actuator. Ball screw models have an anti-coast brake*, that must be released during motion, which is done by connecting orange (4) lead to L1. Acme models do not have any anti-coast brake.