



Electrak® 1 S – Technical Features



Standard Features

- Compact and lightweight
- Integrated end of stroke limit switches
- Corrosion resistant housing
- Self-locking acme screw drive system
- Maintenance free
- Ideal for replacement of comparable size pneumatic and hydraulic cylinders

General Specifications

Screw type	acme
Nut type	acme
Manual override	no
Anti-rotation	no
Static load holding brake	no (self-locking)
Safety features	end of stroke limit switches motor auto reset thermal switch
Electrical connections	flying leads with connector
Compliances	CE, UKCA

Compatible Controls

Contact customer support at www.thomsonlinear.com/cs

Electrak 1 S – Technical Specifications

Mechanical Specifications		
Max. static load ⁽¹⁾	[N (lbf)]	1300 (300)
Max. dynamic load (Fx)	[N (lbf)]	
Sxx -09A04		110 (25)
Sxx -09A08		225 (50)
Sxx -17A08		340 (75)
Sxx -17A16		340 (75)
Speed @ no load/max. load	[mm/s (in/s)]	
Sxx -09A04		78/64 (3.1/2.5)
Sxx -09A08		39/29 1.5/1.1)
Sxx -17A08		21/16 (0.8/0.6)
Sxx -17A16		10/8 (0.4/0.3)
Min. ordering stroke (S) length	[in]	1
Max. ordering stroke (S) length	[in]	8
Ordering stroke length increments	[in]	1
Operating temperature limits	[°C (F)]	-25 – 65 (-13 – 150)
Full load duty cycle @ 25 °C (77 °F)	[%]	25
End play, maximum	[mm (in)]	0.9 (0.04)
Restraining torque	[Nm (lbf-in)]	2.3 (1.7)
Protection class - static		IP66
Salt spray resistance	[h]	96

(1) Max. static load at fully retracted stroke

Electrical Specifications		
Available input voltages ⁽¹⁾	[Vdc]	12, 24
Input voltage tolerance	[%]	± 10
Current draw @ no load/max. load	[A]	
S12 -09A04		0.8/3.8
S12 -09A08		0.8/4.4
S12 -17A08		0.8/4.1
S12 -17A16		0.8/3.8
S24 -09A04		0.4/1.6
S24 -09A08		0.4/2.0
S24 -17A08		0.4/1.9
S24 -17A16		0.4/1.6
Motor leads length	[mm (in)]	100 (4)
Motor leads cross section	[mm ² (AWG)]	1 (18)



Electrak[®] 1 S – Dimensions

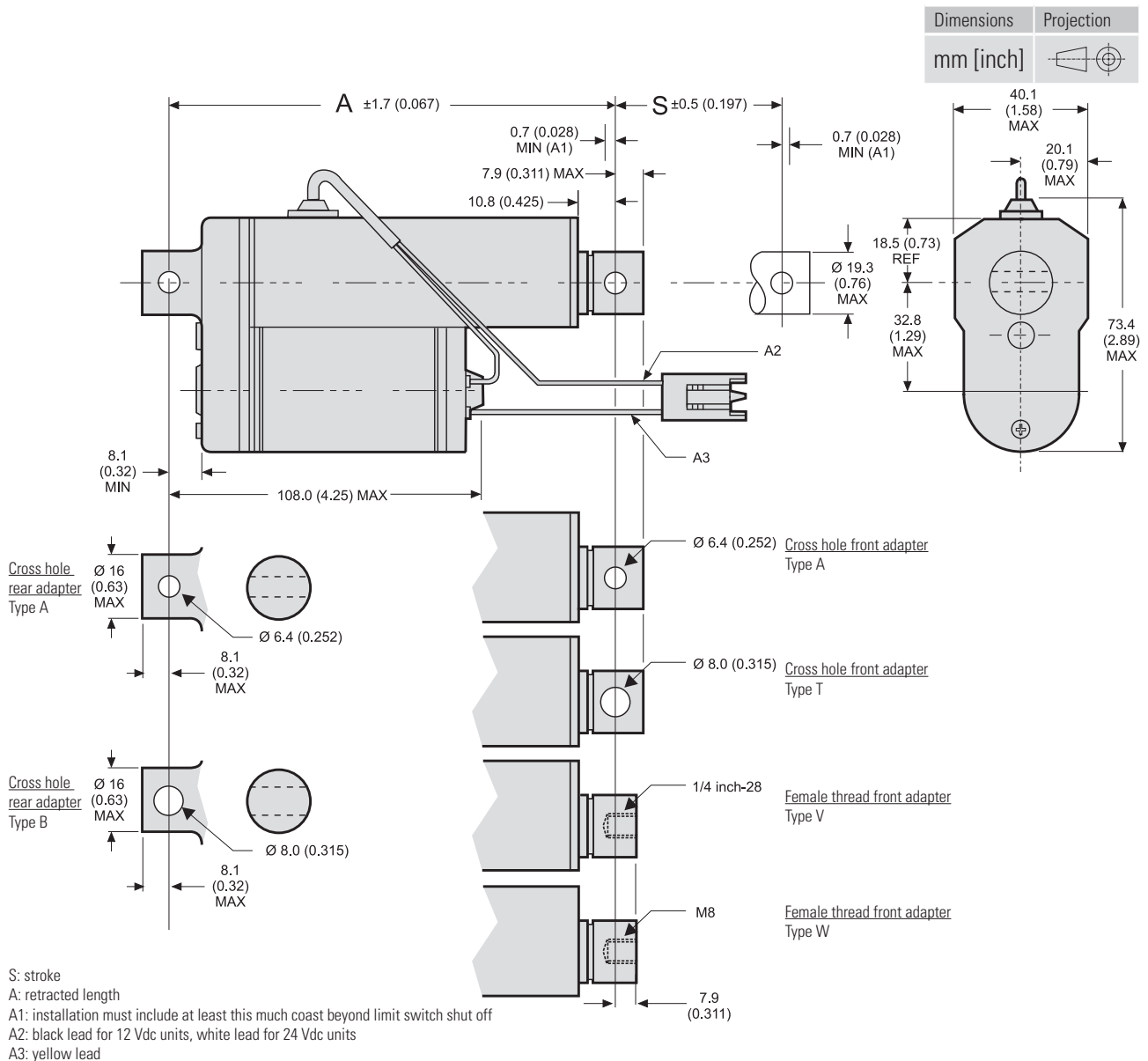

Stroke, Retracted Length and Weight Relationships

Ordering stroke (S)	[in]	1	2	3	4	5	6	8
Electrical stroke*	[mm]	21	46	72	97	122	148	199
	[in]	0.82	1.82	2.82	3.82	4.82	5.82	7.82
Retracted length (A)	[mm]	135	160	185	211	236	262	312
	[in]	5.3	6.3	7.3	8.3	9.3	10.3	12.3
Weight	[kg]	0.52	0.54	0.60	0.64	0.66	0.68	0.74
	[lbs]	1.15	1.20	1.35	1.40	1.45	1.50	1.60

* The electrical stroke occurs when the internal limit switches switch off the power to the motor. The installation then must allow the extension tube to coast at least 0.7 mm (0.028 in) beyond that position before it becomes mechanically blocked to travel any further (distance A1). If there is no mechanical block, the extension tube coasting distance will depend on the load. No load means the longest coasting distance while the distance becomes shorter as the load becomes higher. The exact coasting distance depends on the load, in which direction the load acts (push or pull), the mounting orientation of the actuator, and any added friction to the system by guides or other installations, and has to be determined on a case-by-case basis.

Electrak 1 S – Performance Diagrams

Speed and Current vs. Load 12 Vdc Models

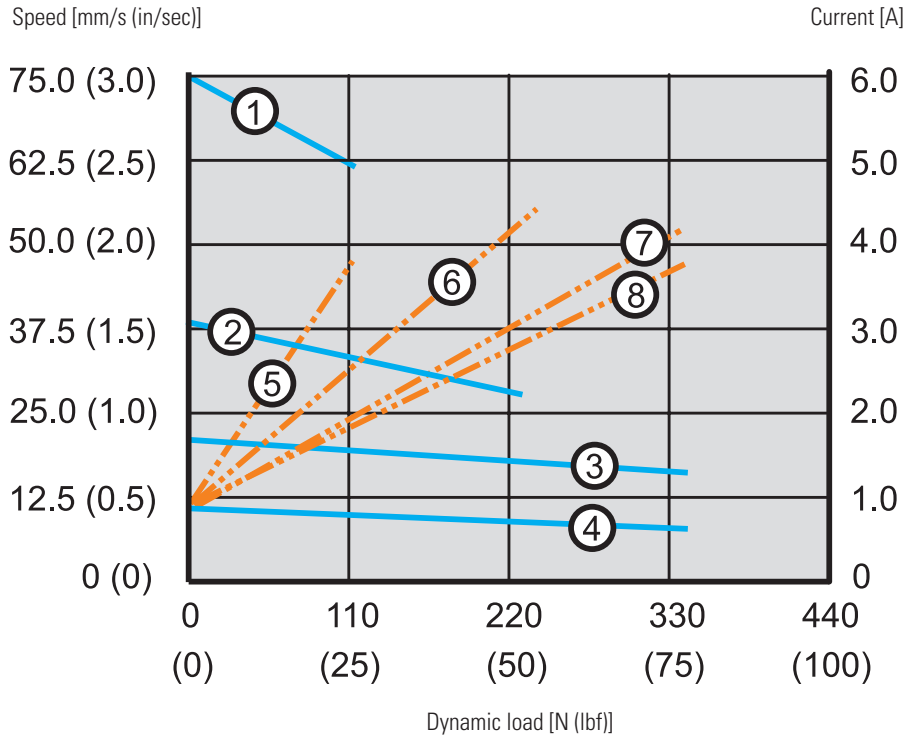

Speed

- 1: S12-09A04 (110 N (25 lbf))
- 2: S12-09A08 (225 N (50 lbf))
- 3: S12-17A08 (340 N (75 lbf))
- 4: S12-17A16 (340 N (75 lbf))

Current

- 5: S12-09A04 (110 N (25 lbf))
- 6: S12-09A08 (225 N (50 lbf))
- 7: S12-17A08 (340 N (75 lbf))
- 8: S12-17A16 (340 N (75 lbf))

Speed and Current vs. Load 24 Vdc Models

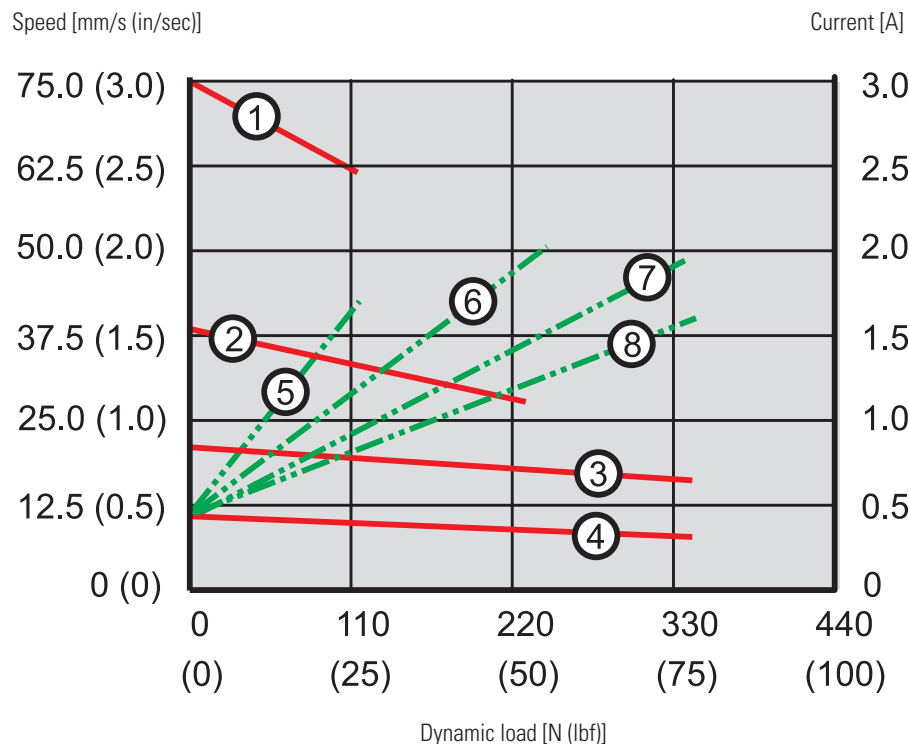

Speed

- 1: S24-09A04 (110 N (25 lbf))
- 2: S24-09A08 (225 N (50 lbf))
- 3: S24-17A08 (340 N (75 lbf))
- 4: S24-17A16 (340 N (75 lbf))

Current

- 5: S24-09A04 (110 N (25 lbf))
- 6: S24-09A08 (225 N (50 lbf))
- 7: S24-17A08 (340 N (75 lbf))
- 8: S24-17A16 (340 N (75 lbf))



Electrak® 1 S – Ordering Key

Ordering Key						
1	2	3	4	5	6	7
S12	C	09A04-	04	-C	A	A
<p>1. Model and input voltage S12 = Electrak 1, 12 Vdc S24 = Electrak 1, 24 Vdc</p> <p>2. CE compliance N = no C = yes</p> <p>3. Dynamic load capacity, screw type and maximum speed 09A04- = 110 N (25 lbf), acme, 75 mm/s (3 in/s) 09A08- = 225 N (50 lbf), acme, 45 mm/s (1,8 in/s) 17A08- = 340 N (75 lbf), acme, 26 mm/s (1 in/s) 17A16- = 340 N (75 lbf), acme, 16 mm/s (0,6 in/s) ⁽¹⁾</p> <p>4. Ordering stroke length 01 = 0.82 inch (21 mm) 02 = 1.82 inch (46 mm) 03 = 2.82 inch (72 mm) 04 = 3.82 inch (97 mm) 05 = 4.82 inch (122 mm) 06 = 5.82 inch (148 mm) 08 = 7.82 inch (199 mm)</p>			<p>5. Connector option -C = Packard Electric Pac-Con -I = AMP Superseal 2 pin</p> <p>6. Front adapter option A = Cross hole 0.25 inch T = Cross hole 8 mm V = Female thread 1/4 inch-28 W = Female thread M8</p> <p>7. Rear adapter option A = Cross hole 0.25 inch B = Cross hole 8 mm</p> <p>(1) Not possible in combination with 8 inch stroke.</p>			

Electrak 1 S – Electrical Connections

Standard

Actuator supply voltage	[Vdc]	
S12		12
S24		24

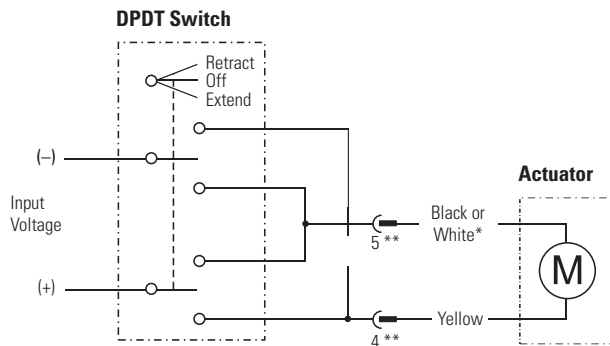

* Black for 12 Vdc supply voltage

White for 24 Vdc supply voltage

** If equipped with AMP Superseal connector

Connect the yellow lead (pin 4 if connector) to positive and black or white (pin 5 if connector) to negative to extend the actuator. Change polarity to retract the actuator. The actuator should be protected from overload conditions by a customer-provided fuse in the circuit (6 A for 12 Vdc and 3 A for 24 Vdc).