

# LOCKING ASSEMBLY MAV 6061

## Installation and Removal Instructions



MAV 6061 Locking Assemblies are supplied ready for installation. If the unit should be dismantled, make sure that all slits are aligned and outer collar item [3] is not reversed. The torque capacity of this device is based on a coefficient of friction of  $\mu=0.12$  for lightly oiled screws, tapers, shaft and hub contact areas. **Therefore, it is important NOT to use Molybdenum Disulfide (e.g., Molykote, Never-Seeze or similar lubricants) in any Locking Assembly installation.**

Recommended shaft / hub bore tolerances: h8 / H8

Recommended shaft / hub bore surface roughness:  $Ra \leq 3.2 \mu\text{m}$

### INSTALLATION - FIG 1

1. Make sure that locking screws, rings, shaft and hub contact surfaces are clean and lightly oiled, and that all slits are aligned and outer collar item [3] is not reversed.
2. Loosen all screws by minimum of 4 turns and transfer at least 3 screws to equally spaced push-off threads in front collar item [1], in order to disengage this part from outer collar item [3]. To disengage rear collar item [2] from taper interface, lightly tap heads of 3 equally spaced locking screws in front collar item [1] that have been engaged at least 4 turns into rear collar item [2]. These operations are required for easy installation of locking assembly.
3. Locking assembly can now be placed on shaft and inserted into hub bore by pushing against face of front collar item [1] while ensuring that rear collar item [2] is not engaged at tapers during this phase.
4. After installation of locking assembly, relocate locking screws used for separation of collars.
5. Hand tighten connection and assure that front collar item [1] is parallel with face of part to be attached to the shaft.
6. Use torque wrench and set it approximately 5% higher than specified tightening torque (Ma). Torque screws in a crosswise pattern, using only 1/4 turns for several passes until 1/4 turns can no longer be achieved.
7. Still apply overtorque for 1-2 more passes. This is required to compensate for a system-related relaxation of locking screws since tightening of a given screw will always relax adjacent screws. Without overtorquing an infinite number of passes would be needed to reach specified tightening torque.
8. Reset torque wrench to specified torque (Ma) and check all locking screws. No screw should turn at this point, otherwise repeat step 7 for 1 or 2 more passes. It is not necessary to re-check tightening torque after equipment has been in operation.

NOTE: for installation subjected to extreme corrosion, the slits in collars item [1] and [2] as well as in outer collar item [3] should be sealed with a suitable caulking compound or equivalent. Likewise, push-off threads should also be protected with set screws or plastic plugs.

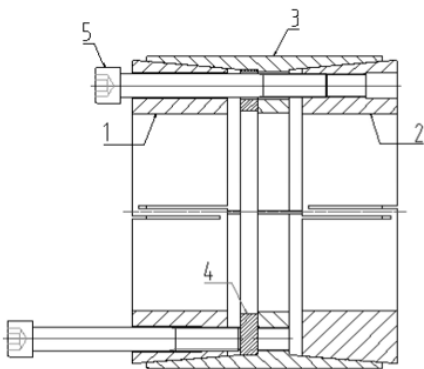

Fig. 1

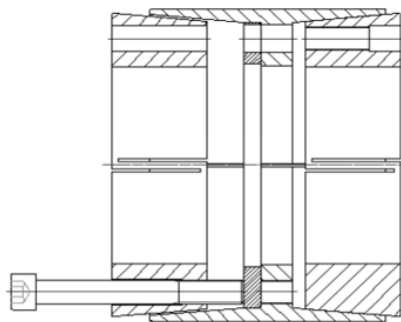

Fig. 2

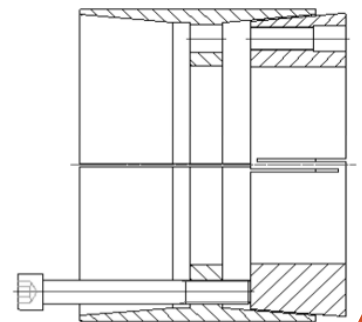

Fig. 3

# LOCKING ASSEMBLY MAV 6061

## Installation and Removal Instructions



### REMOVAL - FIG 2 & 3

**Prior to initiating the following removal procedure, check to ensure that no torque or thrust loads are acting on the Locking Assembly, shaft or any mounted components.**

*IMPORTANT! The final user must ensure that ends of locking screws used for removal are ground flat and slightly chamfered to prevent damage to screws and collar threads during push-off. Screws with ground flat and chamfered end are not supplied by MAV. The final user has to take charge of machining of end of screws.*

1. Check to ensure that axial movement of collars – necessary for release of connection – is not restricted. Likewise, ensure that push-off threads are in good conditions.
2. Remove all locking screws and transfer the required number into all push-off threads in front collar item [1].
3. Release front collar item [1] by tightening all push-off screws in a crosswise pattern, not exceeding 1/4 turns for several passes. Remove front collar item [1] and dismantling ring item [4]. This latter is supplied with some threads (smaller than locking screws diameter) at the collar face for this purpose.
4. Transfer locking screws used for dismounting of front collar item [1] into all push-off threads in outer collar item [3]. Release rear collar item [2] by repeating procedure outlined in step 3.

Information for proper disposal:

