

# LOCKING ASSEMBLIES MAV 3505, 3705 STANDARD STEEL & STAINLESS STEEL

## Installation and Removal Instructions



### GENERAL RECOMMENDATIONS AND WARNINGS

- Before installing or handling this product, read instructions carefully and completely. Due to possible danger to persons or machinery resulting from improper use of this product, it is very important to follow correct procedures. Proper installation, maintenance and operation procedures must be observed. All instructions included in this manual must be followed carefully. Handling, installation and removal of this product must be done by skilled personnel, familiar with the product, the application and all hazards involved.
- Suitable safety devices should be provided and applicable safety rules should be observed as specified in safety codes. Those are neither the responsibility of MAV S.p.A., nor are provided by MAV S.p.A.
- Contravention of install and safety instructions will void all claims under warranty.
- During storage or handling operations, use only tested and approved handling and/or lifting tools. Make always sure that components of the Locking Assembly are secured against slipping, falling or rolling.
- Prior to initiating installation or removal procedures, check to ensure that no loads are acting on Locking Assembly, shafts or any connected components. Motor and drive train must be switched off and secured against accidental activation.

### GENERAL INFORMATION

Locking Assemblies MAV 3505 and MAV 3705 provide a rigid, zero-backlash, frictional keyless connection between a shaft and hubs such as gears, pulleys, cams, levers and many others. They are suited for transmitting torque and axial load, separately or in combination. Applied loads are transmitted via pressure and friction across the fitting surfaces between Locking Assembly, shaft and hub bore. In tightened condition, Locking Assemblies exert high radial pressure on shaft and in hub bore.

**Locking Assemblies MAV 3505 and MAV 3705 are supplied ready for installation and are composed of (fig. 1 and 2):**

- One inner ring (slotted) item [1]
- One outer ring (slotted) item [2]
- One round nut item [3]
- One safety washer item [4] (standard steel version)
- One safety set screw item [5] (stainless steel version)

### Lubrication

Functional values are rated with **locking rings, nut, shaft and hub contact areas coated with a film of mineral or synthetic-base oil** with low content of additives (specific corrosion-protection purpose products as well as products used to release oxidized connections are not recommended). **DON'T USE low friction lubricants** based on molybdenum disulphide, graphite, copper and other similar compounds (e.g., Molykote®, Never-Seeze® or similar products).

Standard as well as stainless steel versions are coated at factory with a film of PETRONAS WHITE OIL P 15 (pharmaceutical grade, see Product Data Sheet).

Recommended shaft / hub bore tolerances: h8 / H8.

Recommended shaft / hub bore surface finish:  $0.8 \leq Ra \leq 3.2 \mu\text{m}$

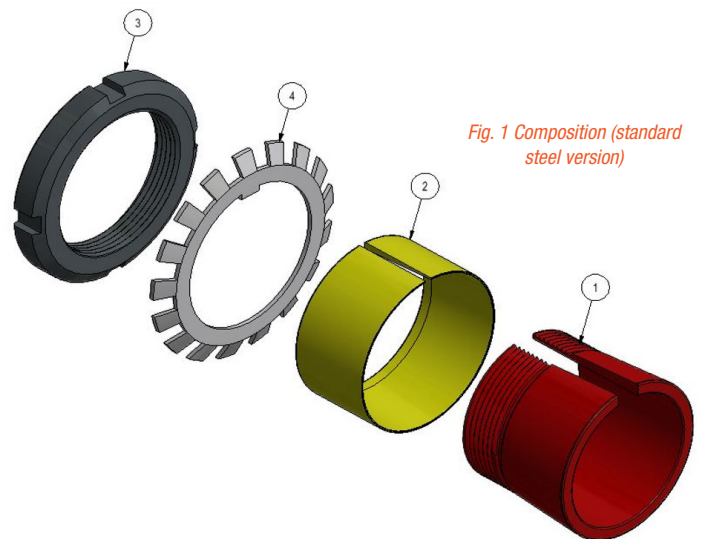

Fig. 1 Composition (standard steel version)

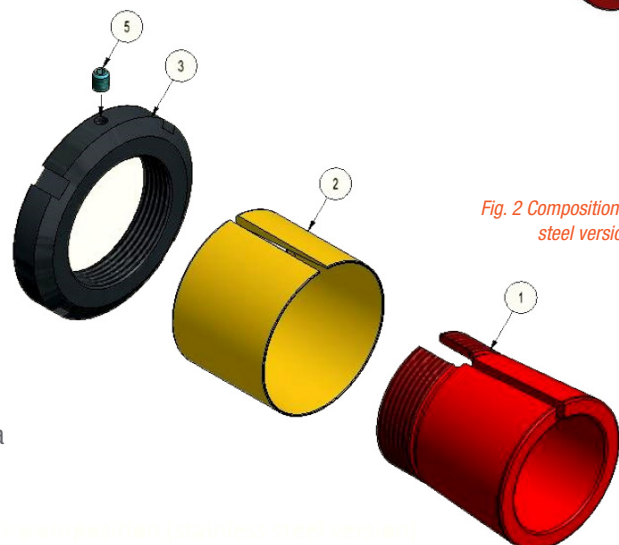

Fig. 2 Composition (stainless steel version)

# LOCKING ASSEMBLIES MAV 3505, 3705 STANDARD STEEL & STAINLESS STEEL

## Installation and Removal Instructions



### Tightening torque

Functional values in the catalog are based on specified tightening torque (Ma). Tight clearance fits are typical of all functional surfaces. Mounting of all parts to be achieved WITHOUT HEATING or ANY OTHER FORCED INSTALLATION.

## INSTALLATION

### SAFETY NOTICE

**Prior to initiating the installation procedure, check to ensure that no loads are acting on Locking Assembly, shaft or any connected component. Motor and drive train must be switched off and secured against accidental activation.**

Locking Assemblies MAV 3505 and MAV 3705 are supplied ready for installation. During tightening of Locking Assembly, an axial displacement of hub respect to shaft will occur.

1. Make sure that nut, locking rings, shaft and hub contact areas are clean and coated with a film of oil.
2. For ease of installation, locking rings shall be disengaged (fig. 3). Loosen the nut by two/three turns and push the outer ring towards the nut.
3. Insert Locking Assembly into the hub bore and make it slide onto the shaft, making sure that connected components are positioned as required. **Inner respectively outer rings shall be completely supported by shaft respectively hub bore (fig. 4).** Installation into hubs with shoulder requires a few mm's gap between inner ring and shoulder (fig. 4).
4. Tighten the nut by hand, until fitting clearances with shaft and hub bore are bridged and connected components are slightly locked, while making sure that hub is aligned as required using a dial indicator. **Better centering of hub from the beginning of installation is essential for better centering when installation is completed.**
5. Use a calibrated torque wrench and tighten the nut to the specified tightening torque (Ma) (fig. 4).
6. Lock the safety washer (standard steel version), or tighten the set screw located in the nut's body (stainless steel version), to prevent loosening of the nut.

NOTE: for connections subject to corrosion, slits in inner and outer rings should be sealed with a suitable caulking compound after installation.

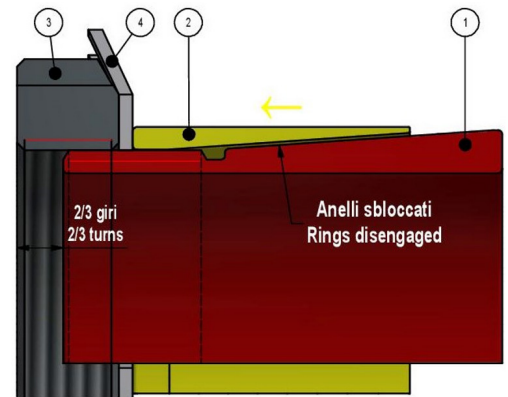

Fig. 3  
Disengagement of locking rings

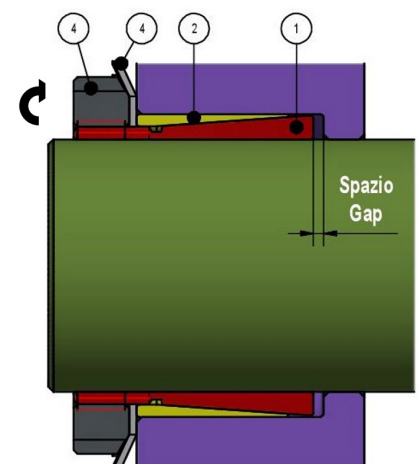

Fig. 4  
Positioning of Locking Assembly  
and tightening of the nut

## REMOVAL

### SAFETY NOTICE

**Prior to initiating the removal procedure, check to ensure that no loads are acting on Locking Assembly, shaft or any connected component. Motor and drive train must be switched off and secured against accidental activation.**

**Prior to removing shaft, hub and Locking Assembly, make always sure that all parts are secured against slipping, falling or rolling.**

1. Unlock the safety washer (standard steel version), or loosen the set screw located in the nut's body (stainless steel version).
2. Loosen the nut until locking rings have released.
  - 2.1. Series MAV 3505 is self releasing. After loosening of the nut, locking rings will release automatically. Shouldn't be the case, light hammering may help.
  - 2.2. Series MAV 3705 is self locking. Releasing will be difficult and can be obtained by means of releasing systems not supplied by MAV.
3. Once the connection is released, shaft, hub and Locking Assembly can be removed.