

# LOCKING ELEMENT MAV 3003

## Installation and Removal Instructions



### GENERAL RECOMMENDATIONS AND WARNINGS

- Before installing or handling this product, read instructions carefully and completely. Due to possible danger to persons or machinery resulting from improper use of this product, it is very important to follow correct procedures. Proper installation, maintenance and operation procedures must be observed. All instructions included in this manual must be followed carefully. Handling, installation, and removal of this product must be done by skilled personnel, familiar with the product, the application and all hazards involved.
- Suitable safety devices should be provided and applicable safety rules should be observed as specified in safety codes. Those are neither the responsibility of MAV S.p.A., nor are provided by MAV S.p.A.
- Contravention of install and safety instructions will void all claims under warranty.
- During storage or handling operations, use only tested and approved handling and/or lifting tools. Make always sure that components of Locking Element are secured against slipping, falling or rolling.
- Prior to initiating installation or removal procedures, check to ensure that no loads are acting on Locking Element, shaft or any connected component. Motor and drive train must be switched off and secured against accidental activation.

### GENERAL INFORMATION

Locking Elements MAV 3003 provide a rigid, zero-backlash, frictional keyless connection between a shaft and hubs such as gears, pulleys, cams, levers, rotors and many others. They are suited for transmitting torque and axial load, separately or in combination. Applied loads are transmitted via pressure and friction across the fitting surfaces between Locking Element, shaft and hub bore. In tightened condition, Locking Elements exert high radial pressure on shaft and in hub bore.

**Locking Elements MAV 3003 are supplied ready for installation and are composed of (fig. 1):**

- One inner ring (solid or slotted executions; slotted up to size d = 8)
- One outer ring (solid or slotted executions; slotted up to size d = 8)

The Locking Element shall be tightened by means of one customer design thrust ring\* and a set of locking screws, which shall be tightened into threaded holes tapped in the hub or shaft's end (fig. 2, 3). Installation may also require spacers. Tightening hardware and spacers are not supplied by MAV S.p.A.

\*The design of the thrust ring shall grant:

- A minimum distance from the face of the hub or shaft end, according to dimension X in the catalog
- A suitable thickness to avoid excessive deflection in tightened condition

The hub must be provided with a centering face to allow good concentricity of the connection, since the Locking Element is not self-centering (fig. 4).

### Lubrication

Functional values are rated with rings of Locking Element, shaft and hub contact areas coated with a film of mineral or synthetic-base oil with low content of additives (specific corrosion-protection purpose products as well as products used to release oxidized connections are not recommended). **DON'T USE low friction lubricants** based on molybdenum disulphide, graphite, copper and other similar compounds (e.g., Molykote®, Never-Seeze® or similar products).

Recommended shaft / hub bore tolerances: see table

Shaft dia. [mm]	Shaft	Hub bore
≤ 38	h6	H7
> 38	h8	H8

Recommended shaft / hub bore surface finish:  $0.4 \leq Ra \leq 0.8 \mu\text{m}$

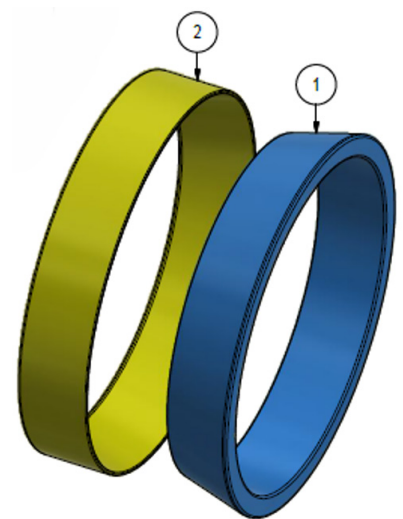

ELEM	QTÀ	DESCRIZIONE
1	1	ANELLO INTERNO / INNER RING
2	1	ANELLO ESTERNO / OUTER RING

Fig. 1 Composition

# LOCKING ELEMENT MAV 3003

## Installation and Removal Instructions



### Tightening torque

Functional values in the catalog are based on specified shaft pressure (Ps). Screws total preload shall equal the sum of assembling and locking loads specified in the catalog (Ca + Cb). In slotted execution, assembling load (Ca) is zero.

After installation is completed, it is usually not necessary to re-check tightening torque after equipment has been in operation. However, loosening of the screws may occur in connections subject to severe operating conditions. In these instances, periodic check of screws tightening torque is recommended.

### INSTALLATION

#### SAFETY NOTICE

**Prior to initiating the installation procedure, check to ensure that no loads are acting on Locking Element, shaft or any connected component. Motor and drive train must be switched off and secured against accidental activation.**

Locking Elements MAV 3003 shall be tightened by means of one customer design thrust ring and a set of locking screws, which shall be tightened into threaded holes tapped in the hub or shaft's end (fig. 2). Installation may also require spacers. **Tightening hardware and spacers are not supplied by MAV S.p.A.** Connections using multiple Locking Elements installed in series are possible.

1. Make sure that rings of the Locking Element, shaft and hub contact areas are clean and coated with a film of oil. Locking screws (by others) shall be lubricated according to user's specifications.
2. Install the parts in the following sequence (fig. 4).
  - a) Hub onto shaft.
  - b) Spacer, to bridge the undercut (it may be not necessary with no undercut).
  - c) Rings of the Locking Element (use of multiple Elements is possible).  
The self-releasing taper allow for ease of installation.
  - d) Spacer, if any, and thrust ring.
  - e) Locking screws.

Make sure that **rings of the Locking Element are completely supported by shaft and hub bore.**

3. Tighten the screws by hand in a crosswise pattern (fig. 5) until fitting clearances with shaft and hub bore are bridged and connected components are slightly locked, while making sure that hub is aligned as required using a dial indicator. The distance (X) between thrust ring and hub or shaft end **shall never be zero and be uniform** around the circumference (fig. 4). **Better centering of hub from the beginning of installation is essential for better centering when installation is completed.**
4. Use a torque wrench set approx. 5% higher than the design tightening torque. **Progressively tighten the screws in a crosswise pattern (fig. 5), using approx. ¼ turns for several passes until ¼ turns can no longer be achieved.**
5. Still apply overtorque for a few more passes. This is required to compensate for a system-related relaxation of the screws since tightening of a given screw will always relax adjacent screws. Without overtorquing, a very large number of passes would be needed to reach specified tightening torque.
6. Reset the torque wrench to the design tightening torque and check all screws in either a clockwise or counterclockwise sequence. The installation is completed as long as no screw can be turned further, otherwise repeat step 5.
7. **Check the distance (X) (fig. 4): the thrust ring must never contact the face of the hub or shaft end. Remaining distance shall be uniform** around the circumference.

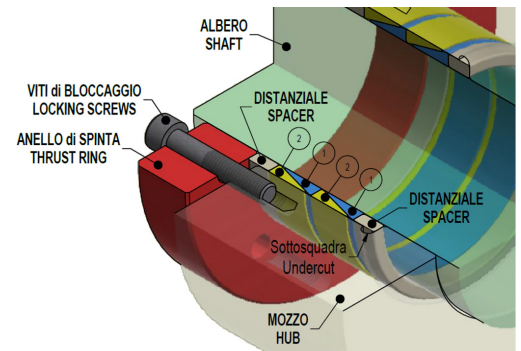

Fig. 2  
Design example w/ tapped hub

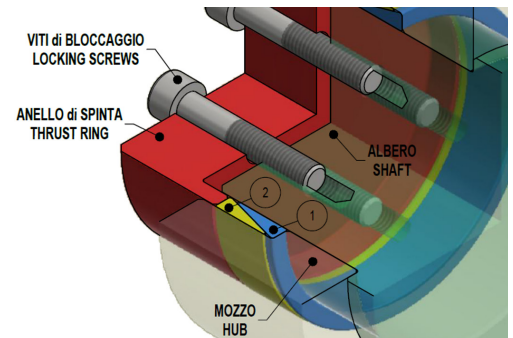

Fig. 3  
Design example w/ tapped shaft.

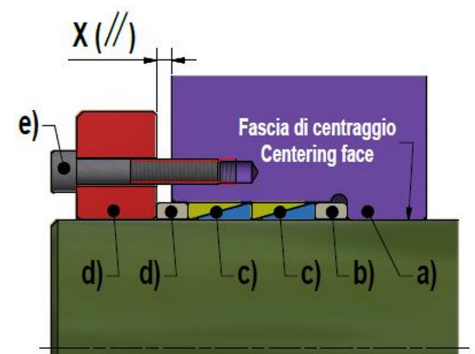

Fig. 4  
Example of mounting sequence

# LOCKING ELEMENT MAV 3003

## Installation and Removal Instructions



### REMOVAL

#### SAFETY NOTICE

Prior to initiating the removal procedure, check to ensure that no loads are acting on Locking Element, shaft or any connected component. Motor and drive train must be switched off and secured against accidental activation.

1. Progressively loosen all screws in several passes until the rings of the Locking Element have released (self-releasing taper). Shouldn't be the case, light tapping will help the disengagement of the Locking Element.

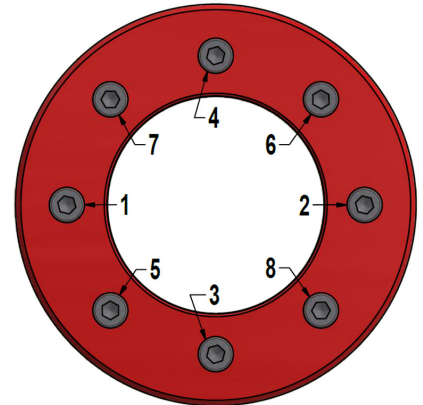

Fig. 5  
Example of tightening pattern

Information for proper disposal:



Dispose MAV  
product as metal