

LOCKING ASSEMBLY MAV 2005

Installation and Removal Instructions



GENERAL RECOMMENDATIONS AND WARNINGS

- Before installing or handling this product, read instructions carefully and completely. Due to possible danger to persons or machinery resulting from improper use of this product, it is very important to follow correct procedures. Proper installation, maintenance, and operation procedures must be observed. All instructions included in this manual must be followed carefully. Handling, installation, and removal of this product must be done by skilled personnel, familiar with the product, the application and all hazards involved.
- Suitable safety devices should be provided and applicable safety rules should be observed as specified in safety codes. Those are neither the responsibility of MAV S.p.A., nor are provided by MAV S.p.A.
- Contravention of install and safety instructions will void all claims under warranty.
- During storage or handling operations, use only tested and approved handling and/or lifting tools. Make always sure that components of Locking Assembly are secured against slipping, falling or rolling.
- Prior to initiating installation or removal procedures, check to ensure that no loads are acting on Locking Assembly, shaft or any connected component. Motor and drive train must be switched off and secured against accidental activation.

GENERAL INFORMATION

Locking Assemblies MAV 2005 provide a rigid, zero-backlash, frictional keyless connection between a shaft and hubs such as gears, pulleys, cams, levers, rotors and many others. They are suited for transmitting torque, axial load, bending moment and radial load, separately or in combination. Applied loads are transmitted via pressure and friction across the fitting surfaces between Locking Assembly, shaft and hub bore. In tightened condition, Locking Assemblies exert high radial pressure on shaft and in hub bore.

Locking Assemblies MAV 2005 are supplied ready for installation and are composed of (fig. 1):

- One inner ring (slotted)
- One outer ring (slotted)
- One front thrust ring, with integrated pull-out threaded holes
- One rear thrust ring
- One set of socket head cap screws ISO 4762 grade 12.9; two/three zinc plated screws are located into the pull-out threaded holes

Lubrication

Functional values are rated with **screws, locking rings, shaft and hub contact areas coated with a film of mineral or synthetic-base oil** with low content of additives (specific corrosion-protection purpose products as well as products used to release oxidized connections are not recommended). **DON'T USE low friction lubricants** based on molybdenum disulphide, graphite, copper and other similar compounds (e.g., Molykote®, Never-Seeze® or similar products).

Recommended shaft / hub bore tolerances: h11 max / H11 max

Recommended shaft / hub bore surface finish: $0.8 \leq Ra \leq 3.2 \mu\text{m}$

Tightening torque

Functional values in the catalog are based on specified tightening torque (Ma). Tightening torque may be reduced up to $0.6 \cdot Ma$ (max reduction by 40%). A given reduction of tightening torque leads to a proportional reduction of functional values.

After installation is completed, it is usually not necessary to re-check tightening torque after equipment has been in operation. However, loosening of the screws may occur in connections subject to severe operating conditions. In these instances, periodic check of screws tightening torque is recommended.

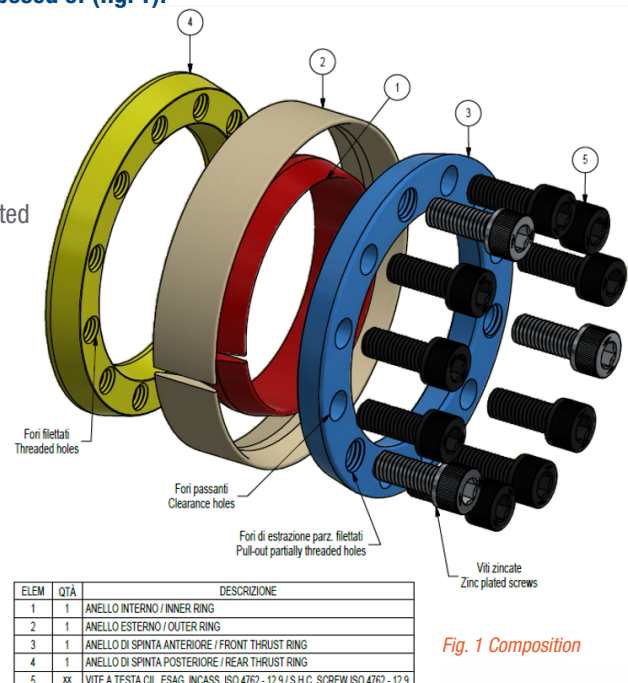

Fig. 1 Composition

LOCKING ASSEMBLY MAV 2005

Installation and Removal Instructions



INSTALLATION

SAFETY NOTICE

Prior to initiating the installation procedure, check to ensure that no loads are acting on Locking Assembly, shaft or any connected component. Motor and drive train must be switched off and secured against accidental activation.

Locking Assemblies MAV 2005 are supplied ready for installation. Should the unit be disassembled and re-assembled, make sure that clearance holes in the front thrust ring are aligned with threaded holes in the rear thrust ring. Zinc plated screws shall be located into the pull-out threaded holes in the front thrust ring. During tightening of Locking Assembly, no axial displacement of hub respect to shaft will occur.

1. Make sure that screws, locking rings, shaft and hub contact areas are clean and coated with a film of oil.
2. For ease of installation, thrust rings shall be disengaged (fig. 2) by loosening all screws by two/three turns.
3. Insert Locking Assembly into the hub bore and make it slide onto the shaft, making sure that connected components are positioned as required. Inner and outer rings shall be completely supported by shaft respectively hub bore (fig. 2). Installation into hubs with shoulder requires a few mm's gap between rear thrust ring and shoulder (fig. 2).
4. Tighten the screws by hand in a crosswise pattern (fig. 3) until fitting clearances with shaft and hub bore are bridged and connected components are slightly locked, while making sure that hub is aligned as required using a dial indicator. Better centering of hub from the beginning of installation is essential for better centering when installation is completed.
5. Use a torque wrench set approx. 5% higher than specified tightening torque (Ma), or reduced within admissible value. Progressively tighten the screws in a crosswise pattern (fig. 3), using approx. 1/4 turns for several passes until 1/4 turns can no longer be achieved.
6. Still apply overtorque for a few more passes. This is required to compensate for a system-related relaxation of the screws since tightening of a given screw will always relax adjacent screws. Without overtorquing, a very large number of passes would be needed to reach specified tightening torque.
7. Reset the torque wrench to specified tightening torque (Ma), or reduced within admissible value, and check all screws in either a clockwise or counterclockwise sequence. The installation is completed as long as no screw can be turned further, otherwise repeat step 6.

NOTE: For connections subject to corrosion, slits in inner and outer rings should be sealed with a suitable caulking compound. Locking Assembly may also be protected with specific covers.

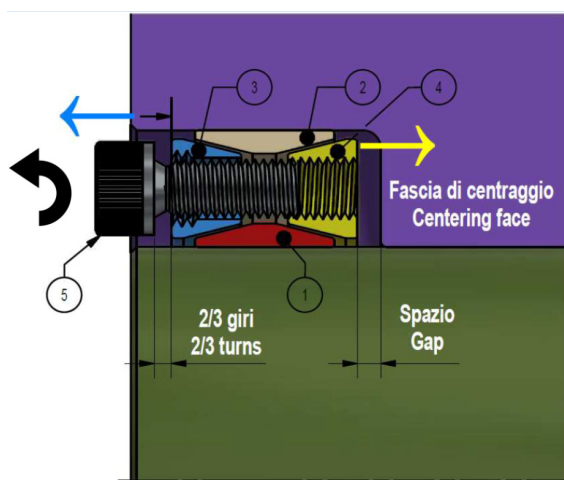

Fig. 2
Disengagement of thrust rings and positioning of Locking Assembly

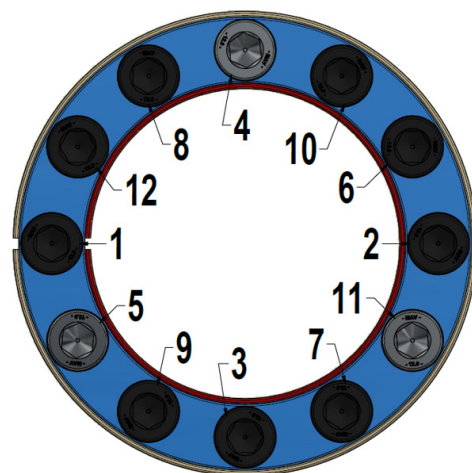

Fig. 3
Example of tightening pattern

LOCKING ASSEMBLY MAV 2005

Installation and Removal Instructions



REMOVAL

SAFETY NOTICE

Prior to initiating the removal procedure, check to ensure that no loads are acting on Locking Assembly, shaft or any connected component. Motor and drive train must be switched off and secured against accidental activation.

1. Ensure that axial movement of front and rear thrust rings – necessary for removal – is not restricted.
2. **Progressively loosen all screws in several passes** until the thrust rings have released (self-releasing tapers). Should the thrust rings jam, light hammering on the head of three equally spaced, pre-loosened screws may be necessary to release the thrust rings (fig. 4).
3. Hub and Locking Assembly are normally removed together. Removal of Locking Assembly from deep counterbores is accomplished using two or three removal screws or threaded rods (supplied by others) turned into the pull-out threaded holes located in the front thrust ring under the zinc plated screws (fig. 4).

The pull-out holes are NOT to be used for high pulling forces. The diameter of pull-out threaded holes is larger than the diameter of locking screws (see table below).

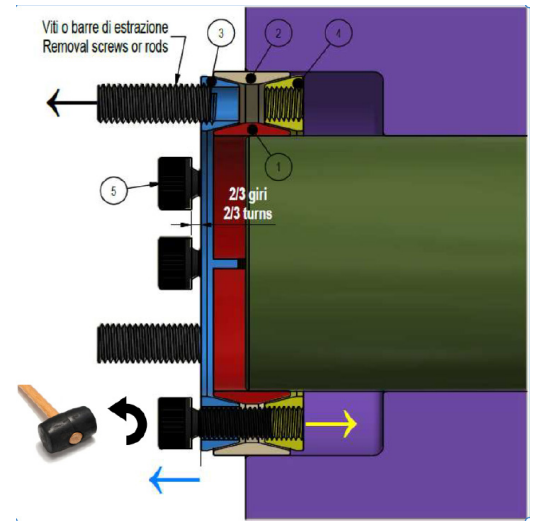

Fig. 4
Release of thrust rings and removal of Locking Assembly

Locking screw dia.	M6	M8	M10	M12	M14	M16	M18	M20	M22	M24
Pull-out thread dia.	M8	M10	M12	M14	M16	M20	M22	M24	M27	M30

Information for proper disposal:

