

# LOCKING ASSEMBLIES MAV 4071, 1800

## Installation and Removal Instructions



### GENERAL RECOMMENDATIONS AND WARNINGS

- Before installing or handling this product, read instructions carefully and completely. Due to possible danger to machinery or persons resulting from improper use of this product, it is very important to follow correct procedures. Proper installation, maintenance and operation procedures must be observed. All instructions included in this manual must be followed carefully. Handling, installation and removal of this product must be done by skilled personnel, familiar with the product, the application and all hazards involved.
- Suitable safety devices should be provided and applicable safety rules should be observed as specified in safety codes. Those are neither the responsibility of MAV S.p.A., nor are provided by MAV S.p.A.
- Contravention of install and safety instructions will void all claims under warranty.
- During storage or handling operations, use only tested and approved handling and/or lifting tools. Make always sure that components of Locking Assembly are secured against slipping, falling or rolling.
- Prior to initiating installation or removal procedures, check to ensure that no loads are acting on Locking Assembly, shaft or any connected component. Motor and drive train must be switched off and secured against accidental activation.

### GENERAL INFORMATION

Locking Assemblies MAV 4071 and MAV 1800 provide a rigid, zero-backlash, frictional keyless connection between a shaft and hubs such as gears, pulleys, cams, levers, rotors and many others. They are suited for transmitting torque, axial load, bending moment and radial load, separately or in combination. Applied loads are transmitted via pressure and friction across the fitting surfaces between Locking Assembly, shaft and hub bore. In tightened condition, Locking Assemblies exert high radial pressure on shaft and in hub bore.

**Locking Assemblies MAV 4071 and MAV 1800 are supplied ready for installation and are composed of (fig. 1):**

- One inner ring (slotted)
- Two outer rings (slotted)
- One double-cone front thrust ring
- One double-cone rear thrust ring
- One set of socket head cap screws ISO 4762 grade 12.9

### Lubrication

Functional values are rated with **screws, locking rings, shaft and hub contact areas coated with a film of mineral or synthetic-base oil** with low content of additives (specific corrosion-protection purpose products as well as products used to release oxidized connections are not recommended). **DON'T USE low friction lubricants** based on molybdenum disulphide, graphite, copper and other similar compounds (e.g., Molykote®, Never-Seeze® or similar products).

Recommended shaft / hub bore tolerances: h8 / H8.

Recommended shaft / hub bore surface finish:  $0.8 \leq Ra \leq 3.2 \mu\text{m}$

### Tightening torque

Functional values in the catalog are based on specified tightening torque (Ma). Tightening torque may be reduced up to:

- $0.8 \cdot Ma$  (max reduction by 20%) for series MAV 4071
- $0.5 \cdot Ma$  (max reduction by 50%) for series MAV 1800

A given reduction of tightening torque leads to a proportional reduction of functional values.

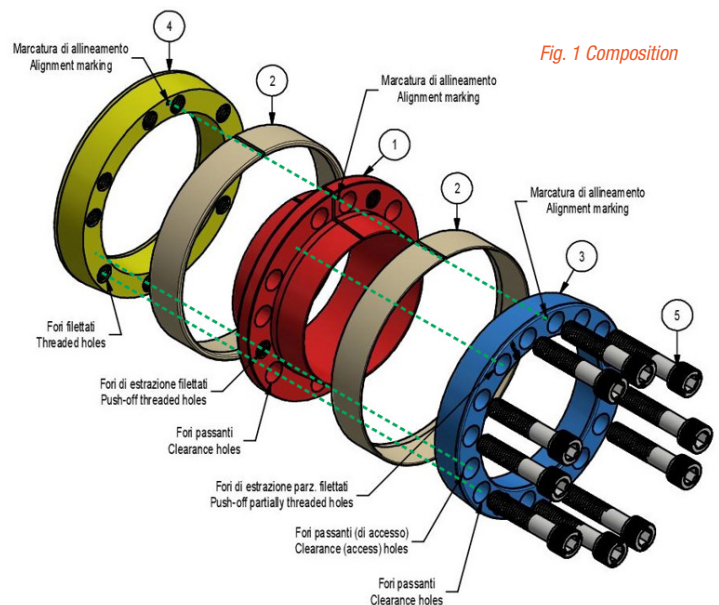

Fig. 1 Composition

ELEM	QTA	DESCRIZIONE
1	1	ANELLO INTERNO / INNER RING
2	2	ANELLO ESTERNO / OUTER RING
3	1	ANELLO DI SPINTA DOPPIO-CONICO ANTERIORE / DOUBLE-CONE FRONT THRUST RING
4	1	ANELLO DI SPINTA DOPPIO-CONICO POSTERIORE / DOUBLE-CONE REAR THRUST RING
5	xx	VITE A TESTA CIL. ESAG. INCASS. ISO 4762 - 12.9 / S.H.C. SCREW ISO 4762 - 12.9

# LOCKING ASSEMBLIES MAV 4071, 1800

## Installation and Removal Instructions



After installation is completed, it is usually not necessary to re-check tightening torque after equipment has been in operation. However, loosening of the screws may occur in connections subject to severe operating conditions. In these instances, periodic check of screws tightening torque is recommended.

### INSTALLATION

#### SAFETY NOTICE

**Prior to initiating the installation procedure, check to ensure that no loads are acting on Locking Assembly, shaft or any connected component. Motor and drive train must be switched off and secured against accidental activation.**

Locking Assemblies MAV 4071 and MAV 1800 are supplied ready for installation. Should the unit be disassembled and re-assembled, make sure that neither clearance nor threaded holes in the inner ring are below the partially threaded holes in the front thrust ring as well as no holes in the rear thrust ring are below the threaded holes in the inner ring. Thrust rings as well as inner ring are engraved with a circular marking: make sure that all markings are aligned (fig. 1, dashed lines). During tightening of Locking Assembly, no axial displacement of hub respect to shaft will occur.

1. Make sure that screws, locking rings, shaft and hub contact areas are clean and coated with a film of oil.
2. For ease of installation, thrust rings shall be disengaged (fig. 2). Loosen all screws by two/three turns; then transfer and hand tighten at least two screws into the push-off threaded holes in the front thrust ring and at least two screws into the push-off threaded holes in the inner ring, accessible via corresponding clearance holes in the front thrust ring.
3. Insert Locking Assembly into the hub bore and make it slide onto the shaft, making sure that connected components are positioned as required. **Inner respectively outer rings shall be completely supported by shaft respectively hub bore (fig. 2).** At this point, relocate the screws used to disengage the thrust rings. Installation into hubs with shoulder requires a few mm's gap between rear thrust ring and shoulder (fig. 2).
4. Tighten the screws by hand in a crosswise pattern, starting from a screw located at 90° approx. respect to slit in the inner ring (fig. 3), until fitting clearances with shaft and hub bore are bridged and connected components are slightly locked, while making sure that hub is aligned as required using a dial indicator. **Better centering of hub from the beginning of installation is essential for better centering when installation is completed.**
5. Use a torque wrench set approx. 5% higher than specified tightening torque (Ma), or reduced within admissible value. **Progressively tighten the screws in a crosswise pattern (fig. 3), using approx. ¼ turns for several passes** until ¼ turns can no longer be achieved.
6. Still apply overtorque for a few more passes. This is required to compensate for a system-related relaxation of the screws since tightening of a given screw will always relax adjacent screws. Without overtorquing, a very large number of passes would be needed to reach specified tightening torque.
7. Reset the torque wrench to specified tightening torque (Ma), or reduced within admissible value, and check all screws in either a clockwise or counterclockwise sequence. The installation is completed as long as no screw can be turned further, otherwise repeat step 6.

NOTE: for connections subject to corrosion, slits in inner and outer rings should be sealed with a suitable caulking compound and push-off threads should be plugged. Locking Assembly may also be protected with specific covers.

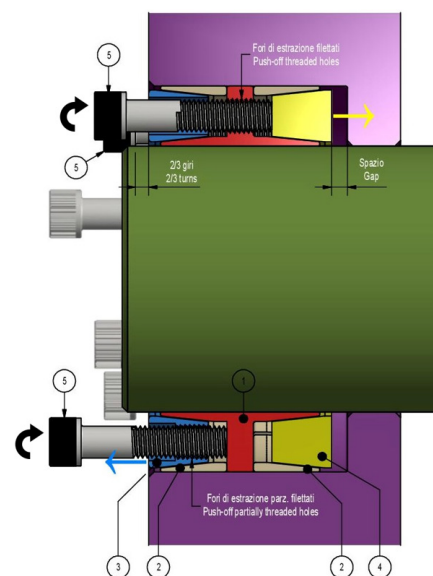

Fig. 2  
Disengagement of thrust rings and positioning of Locking Assembly

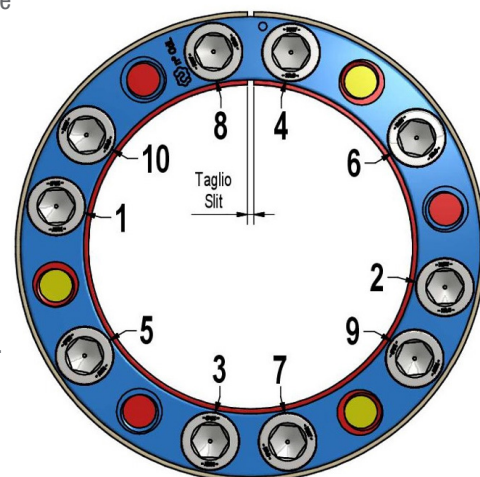

Fig. 3  
Example of tightening pattern

# LOCKING ASSEMBLIES MAV 4071, 1800

## Installation and Removal Instructions



### REMOVAL

#### SAFETY NOTICE

Prior to initiating the removal procedure, check to ensure that no loads are acting on Locking Assembly, shaft or any connected component. Motor and drive train must be switched off and secured against accidental activation.

Some locking screws will be used for removal. The user shall make sure that the end tip of these screws is ground flat and chamfered, in order to prevent damage to the threads and allow their removal from push-off threaded holes. Screws with ground flat and chamfered end tip are not included in the scope of delivery.

Locking rings shall be removed all together from hub bore. Do not remove locking rings separately. The rear thrust ring shall be released at first; releasing of the front thrust ring will follow.

1. Ensure that axial movement of both front and rear thrust rings – necessary for removal – is not restricted. Likewise, ensure that push-off threaded holes are in good conditions.
2. Loosen all screws by two/three turns; then transfer some screws into all push-off threaded holes in the inner ring, accessible via corresponding clearance holes in the front thrust ring. **Progressively tighten these screws in a crosswise pattern, using approx. ¼ turns for several passes** until rear thrust ring is released (fig. 4). **Leave the screws in place after rear thrust ring is released.**
3. Transfer some screws into all push-off partially threaded holes in the front thrust ring. **Progressively tighten these screws in a crosswise pattern, using approx. ¼ turns for several passes** until front thrust ring is released (fig. 5). **Leave the screws in place after front thrust ring is released.**
4. Hold the head of some screws still engaged in the rear thrust ring. Pull out these screws in order to remove locking rings all together from hub bore (fig. 6).

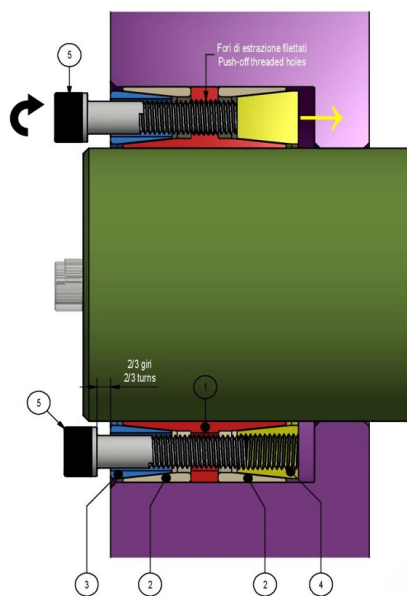

Fig. 4  
Release of rear thrust ring

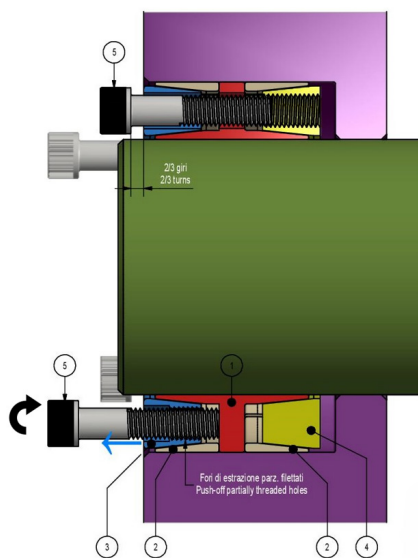

Fig. 5  
Release of front thrust ring

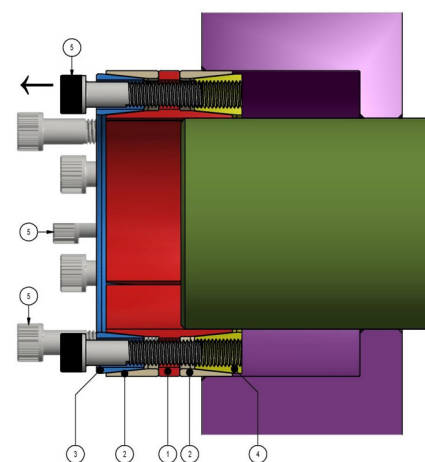

Fig. 6  
Removal of Locking Assembly

