

KOMATSU[®]

PC200-8M0 PC200LC-8M0



PC200-8M0 PC200LC-8M0

HORSEPOWER

Gross: 110 kW 147 hp / 2,000 min⁻¹
Net: 103 kW 138 hp / 2,000 min⁻¹

OPERATING WEIGHT

PC200-8M0: 19,800 - 20,500 kg
PC200LC-8M0: 20,700 - 21,700 kg

BUCKET CAPACITY

0.50 – 1.20 m³

ORIGIN JAPAN / KLTD

Photos of the equipment are referential, may include optional equipment.

I WALK-AROUND

ENGINE
POWER
147 hp



*Photo may include optional equipment.

ECOLOGY & ECONOMY

- »Low fuel consumption by total control of the engine, hydraulic and electronic system
- »Low emission engine
- »Low operation noise

COMFORT & SAFETY

- »Large comfortable cab
- »ROPS Cab (ISO 12117-2)
- »Rear view monitor system (optional)

ICT* & KOMTRAX

- »Large multi-lingual high resolution liquid crystal display (LCD) monitor
- »Equipment management monitoring system
- »KOMTRAX

* Information and communication technology

MAINTENANCE & RELIABILITY

- »Easy maintenance
- »High rigidity work equipment



PC200-8M0

PC200LC-8M0

HORSEPOWER	Gross: 110 kW 147 hp / 2,000 min ⁻¹ Net: 103 kW 138 hp / 2,000 min ⁻¹	110 kW 147 hp / 2,000 min ⁻¹ 103 kW 138 hp / 2,000 min ⁻¹
OPERATING WEIGHT	19,800 - 20,500 kg	20,700 - 21,700 kg
BUCKET CAPACITY	0.50 - 1.20 m ³	0.50 – 1.20 m ³

ECOLOGY & ECONOMY

»Low fuel consumption

»The newly-developed Komatsu SAA6D107E-1 engine enables NOx emissions to be significantly reduced with the accurate multi-staged fuel injection by the engine controller. It improves total engine durability using the high-pressure fuel injection system developed specifically for construction machinery. This excavator significantly reduces hourly fuel consumption using the highly-efficient matching techniques of the engine and hydraulic unit and also provides features that promote energy-saving operations such as the E mode and ECO gauge.

Fuel consumption

7% reduced

Vs. PC200-8

Based on typical work pattern collected via KOMTRAX.
Fuel consumption varies depending on job conditions.

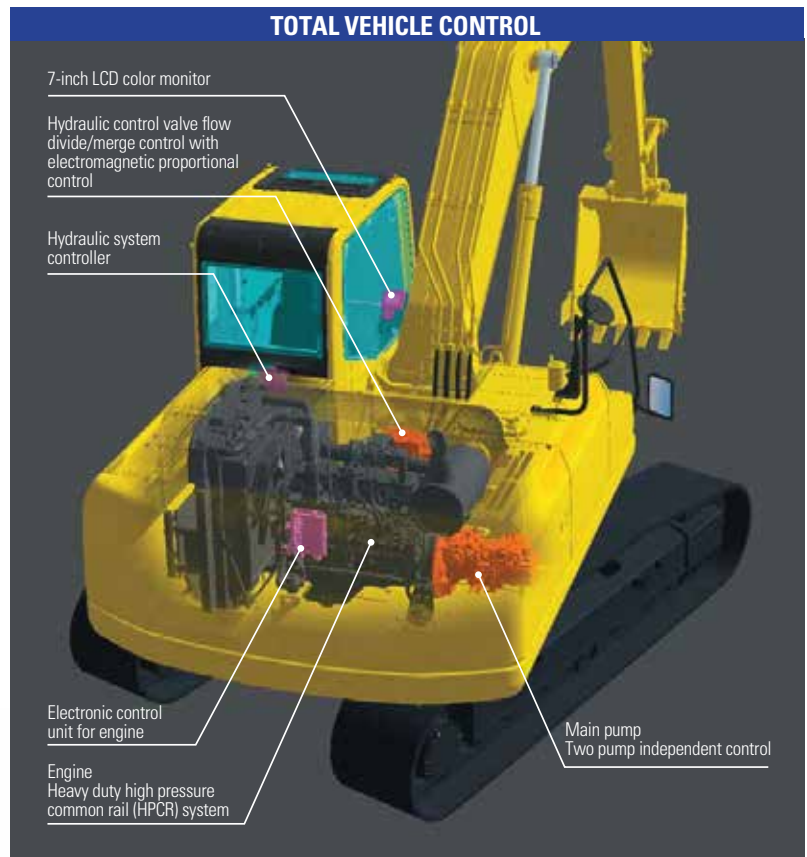

»Komatsu technology

»Komatsu develops and produces all major components, such as engines, electronics and hydraulic components, in house. With this "Komatsu Technology" and adding customer feedback, Komatsu is achieving great advancements in technology. To achieve both high levels of productivity and economical performance, Komatsu has developed the main components with a total control system. The result is a new generation of high performance and environment friendly excavators.



»Low emission engine

»Komatsu SAA6D107E-1 reduced NOx emission by 29% compared with the PC200-7. This engine is U.S. EPA Tier 3 and EU Stage 3A emissions equivalent.



»Low operation noise

»Enables a low-noise operation using the low-noise engine and methods to cut noise at source.

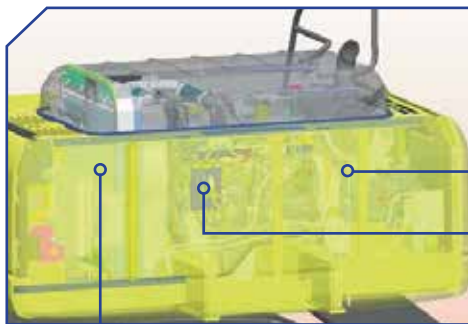

Low-noise muffler
Optimal arrangement of sound absorbing materials

Electronically controlled common rail type engine
• Multi-staged injection
• Highly rigid cylinder block

Reduced fan speed
• Large capacity radiator
• V shape type fin
• Low-noise shroud

»Idling caution

»To prevent unnecessary fuel consumption, an idling caution is displayed on the monitor, if the engine idles for 5 minutes or more.



»ECO gauge that assists energy-saving operations

»Equipped with the ECO gauge that can be recognized at a glance on the right of the multi-function color monitor for environment-friendly energy saving operations. Allows focus on operation in the green range with reduced CO₂ emissions and efficient fuel consumption.



ECO gauge

»Working modes selectable

»The PC200-8M0 excavator is equipped with six working modes (P, E, L, B, ATT/P and ATT/E mode). Each mode is designed to match engine speed and pump output to the application. This provides the flexibility to match equipment performance to the job at hand.

Working mode	Application	Advantage
P	Power mode	<ul style="list-style-type: none"> • Maximum production/power • Fast cycle times
E	Economy mode	<ul style="list-style-type: none"> • Good cycle times • Better fuel economy
L	Lifting mode	<ul style="list-style-type: none"> • Suitable attachment speed • Lifting capacity is increased 7% by raising hydraulic pressure.
B	Breaker mode	<ul style="list-style-type: none"> • Optimum engine rpm, hydraulic flow
ATT/P	Attachment power mode	<ul style="list-style-type: none"> • Optimum engine rpm, hydraulic flow, 2 way • Power mode
ATT/E	Attachment economy mode	<ul style="list-style-type: none"> • Optimum engine rpm, hydraulic flow, 2 way • Economy mode



- P** Work priority
P mode
- E** Fuel priority
E mode
- L** **L mode**
- B** **B mode**
- ATT/P** Work priority
ATT/P mode
- ATT/E** Fuel priority
ATT/E mode

»Large digging force

»When pressing the left knob switch which is called the one-touch power max. switch and when it is kept pressed, this function temporarily increases digging force for 8.5 seconds of operation.

Maximum arm crowd force (ISO 6015):

101 kN (10.3t) ➔ **108 kN (11.0t) 7% UP**
(with Power Max.)

Maximum bucket digging force (ISO 6015):

138 kN (14.1t) ➔ **149 kN (15.2t) 8% UP**
(with Power Max.)

*Measured with Power Max function, 2,925 mm arm and ISO 6012 rating.



One-touch power max. switch

COMFORT



»Low cab noise

»The newly-designed cab is highly rigid and has excellent sound absorption ability. Thorough improvement of noise source reduction and use of low noise engine, hydraulic equipment, and air conditioner allows this machine to generate a low level of noise.

»Low vibration with cab damper mounting

»PC200-8M0 uses viscous damper mounting for cab that incorporates longer stroke and the addition of a spring. The new cab damper mounting combined with high rigidity deck aids vibration reduction at operator seat.

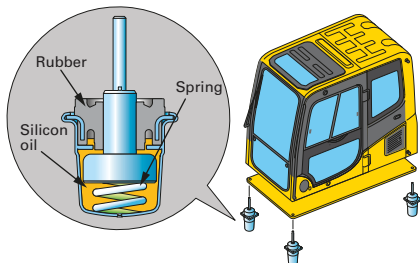

»Wide newly-designed cab

»Newly-designed wide spacious cab includes seat with reclining backrest. The seat height and longitudinal inclination are easily adjusted using a pull-up lever. You can set the appropriate operational posture of armrest together with the console. Reclining the seat further enables you to place it into the fully flat state with the headrest attached.



»Pressurized cab

»Optional air conditioner, air filter and a higher internal air pressure minimize external dust from entering the cab.

»Automatic air conditioner (A/C) (optional)

»Enables you to easily and precisely set cab atmosphere with the instruments on the large LCD. The bi-level control function keeps the operator's head and feet cool and warm respectively. This improved air flow function keeps the inside of the cab comfortable throughout the year. Defroster function keeps front glass clear.

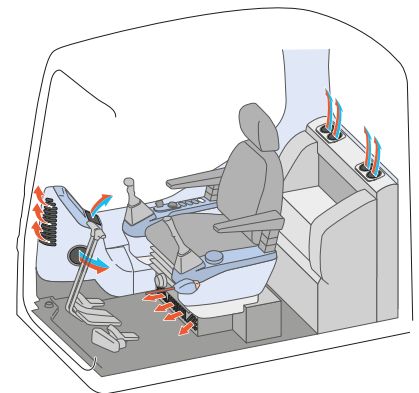

SAFETY

»ROPS Cab

»The machine is equipped with a ROPS cab that conforms to ISO 12117-2 for excavators as standard equipment. The ROPS cab has high shock-absorption performance, featuring excellent durability and impact strength. It also satisfies the requirements of OPG top guard level 1 (ISO 10262) for falling objects. Combined with the retractable seat belt, the ROPS cab protects the operator in case of tipping over and against falling objects.

ROPS CAB STRUCTURE



»Lock lever

»Locks the hydraulic pressure to prevent unintentional movement. Neutral start function allows machine to be started only in lock position.



»Large side-view, rear and sidewise mirrors

»Enlarged left-side mirror and addition of rear and side mirror allow the PC200-8M0 to meet the visibility requirements (ISO 5006).



»Rear view monitor system (optional)

»The operator can view the rear of the machine with a color monitor screen.

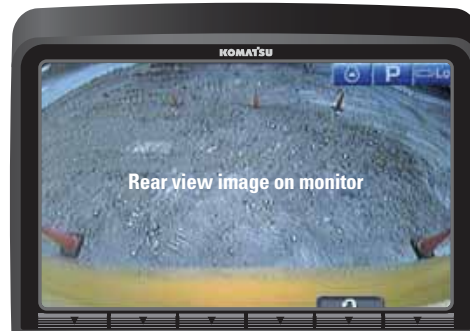

»Slip-resistant plates

»Highly durable slip-resistant plates maintain superior traction performance for the long term.



»Thermal and fan guards

»Thermal and fan guards are placed around high-temperature parts of the engine and fan drive.



»Pump/engine room partition

»Pump/engine room partition prevents oil from spraying onto the engine if a hydraulic hose should burst.

ICT & KOMTRAX

LARGE HIGH RESOLUTION LCD MONITOR



»Large multi-lingual high resolution LCD monitor

»A large user-friendly high resolution LCD color monitor enables safe, accurate and smooth work. Visibility and resolution are further improved compared to current 7-inch large LCD. Simple and easy to operate switches. Function keys facilitate multifunction operations. Displays data in 13 languages to globally support operators around the world.

Indicators

- 1 Auto-decelerator
- 2 Working mode
- 3 Travel speed
- 4 Engine water temperature gauge
- 5 Hydraulic oil temperature gauge
- 6 Fuel gauge
- 7 ECO gauge
- 8 Fuel consumption gauge
- 9 Function switches menu

Basic operation switches

- 1 Auto-decelerator
- 2 Working mode selector
- 3 Traveling selector
- 4 Buzzer cancel
- 5 Wiper
- 6 Windshield washer

»Supports efficiency improvement

»The main screen displays advices for promoting energy-saving operations as needed. The operator can use the ECO guidance menu to check the operation records, ECO guidance records, average fuel consumption logs, etc.

»Equipment management monitoring system



»Monitor function

»Controller monitors engine oil level, coolant temperature, battery charge, air clogging, etc. If the controller finds any abnormality, it is displayed on the LCD.



»Maintenance function

»The monitor informs replacement time of oil and filters on the LCD when the replacement interval is reached.



ECO guidance



ECO guidance menu



ECO guidance records

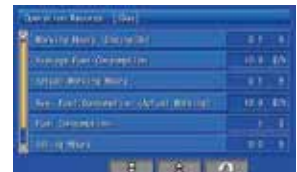

Operation records



Average fuel consumption logs

»Trouble data memory function

»Monitor stores abnormalities for effective troubleshooting.



SATELLITE MONITORING SYSTEM

KOMTRAX is a revolutionary tracking system designed to save time and money. Nowadays, the equipment can be tracked anytime and anywhere. This valuable data, received via the KOMTRAX website, can be used to optimize planning of the movements and performance of the equipment.

FEATURES

» LOCATION

KOMTRAX uses a satellite positioning network to inform the location of the equipment.

» GEOFENCE

In partnership with your Komatsu Distributor, owners can create virtual fences (Geo) to receive alerts when the equipment enters or leaves the designated range for operations.

» SERVICE METER READING

Daily report of the working hours of the equipment, which allows planning maintenance and replacement of components.

» KOMTRAX OPERATION MAPS

In the operation maps you can check the times of the day when the equipment is in operation and if the workers are performing their duties in the stipulated times.

» FUEL MEASUREMENT LEVEL

Shows the amount of fuel at the end of the working day.

» WATER TEMPERATURE DAILY RECORD

Constant record of the increase of engine water temperature with a daily report at the end of the day.

» CAUTIONS

If a light turns on in the cab of the equipment it indicates that a problem occurs. From the website of the application you can review the reason for the problem, the time it occurred and a record number will be generated.

» ABNORMALITY CODES

Abnormality codes are transmitted to the Komatsu Distributor for troubleshooting before technicians arrive at the workplace. An email notification is also sent with the code of what happened.

» NOTICE OF MAINTENANCE REPLACEMENT

The system generates alerts to inform that the equipment requires change of elements like filters and oil.

» EQUIPMENT KEY HOURS

Detailed information on key equipment hours such as excavation, moving, digging, alleviating and elevation. This can help to monitor and compare equipment performance, in addition to working hours and idle times.

» LOADING FREQUENCY

Information on the load factor of the equipment to know if it is performing a light, medium or heavy work.

» ANTI-THEFT ENGINE LOCK

KOMTRAX has a system to lock and unlock the motor of the equipment, which will allow the operation only on preset days, hours and areas.

KOMTRAX

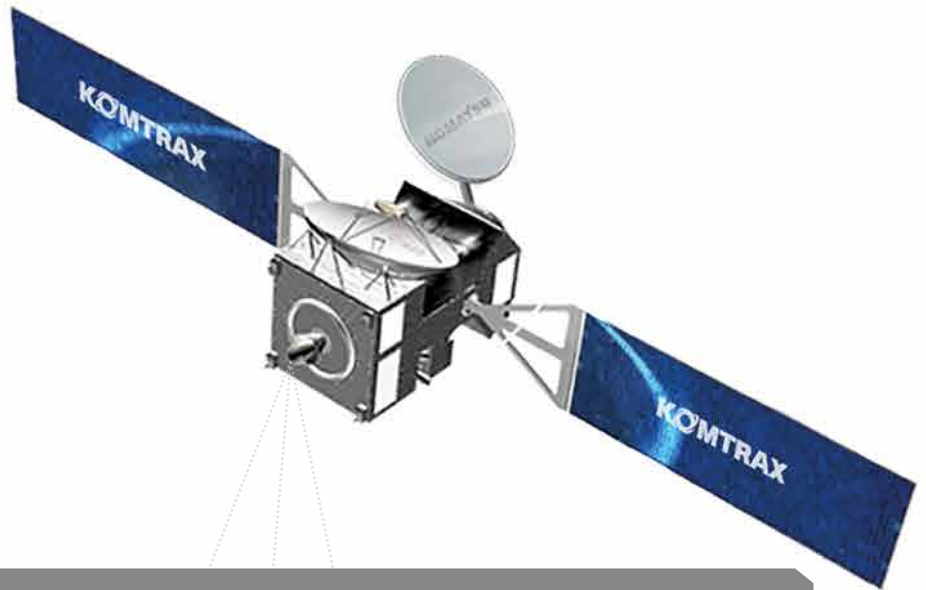

FEATURES

» FUEL CONSUMPTION

On new Komatsu equipment, you can get the actual status of the fuel gallons consumed, besides an average of the fuel spent per hour during the period of operation.

» MONTHLY AND ANNUAL DATA REPORTS

KOMTRAX generates summaries of all critical system data to help with analysis of fleet utilization, equipment scheduling, future equipment purchases, labor costs, etc.

Check with your Komatsu dealer for the information available for your model and service availability in your country.



MAINTENANCE

»Side-by-side cooling

»Since radiator, aftercooler and oil cooler are arranged in parallel, it is easy to clean, remove and install them. Radiator, aftercooler, and oil cooler made of aluminum have high cooling efficiency and are easily recycled.



»Equipped with the fuel pre-filter (with water separator)

»Removes water and contaminants in the fuel to prevent fuel problems. (With built-in priming pump).



»Washable cab floormat

»The PC200-8M0's cab floormat is easy to keep clean. The gently inclined surface has a flanged floormat and drainage holes to facilitate runoff.



»Easy access to engine oil filter and fuel drain valve

»Engine oil filter and fuel drain valve are remote mounted to improve accessibility.



»Equipped with the drain valve as standard

»Prevents clothes and the ground from becoming contaminated due to oil leakage when replacing the engine oil.



»Large-capacity fuel tank and rustproof treatment

»400-liter high-capacity fuel tank. Effective corrosion resistance using rust-proof treatment.

»Sloping track frame

»Prevents dirt and sand from accumulating and allows easy mud removal.

»Gas assisted engine hood damper cylinders

»The engine hood can be easily opened and closed with the assistance of the gas assisted engine hood damper cylinders.



»Long-life oil, filter

»Uses high-performance filtering materials and long-life oil. Extends the oil and filter replacement interval.

Engine oil & engine oil filter	every 500 hours
Hydraulic oil	every 5,000 hours
Hydraulic oil filter	every 1,000 hours

»A/C filter (optional)

»The A/C filter is removed and installed without the use of tools facilitating filter maintenance.



Internal A/C filter

External A/C filter

»Long work equipment greasing interval (optional)

»High quality bushings and resin shims are optionally available for work equipment pins excluding bucket, extending greasing interval to 500 hours.

RELIABILITY

»Sturdy frame structure

»The revolving frame, center frame and undercarriage are designed by using the most advanced three-dimensional CAD and Finite Element Method (FEM) analysis technology.

»Reliable components

»All of the major machine components, such as engine, hydraulic pumps, hydraulic motors and control valves are exclusively designed and manufactured by Komatsu.

»Grease sealed track

»PC200-8M0 uses grease sealed tracks for extended undercarriage life.

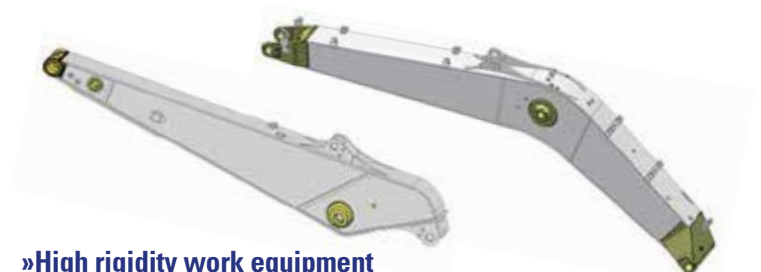
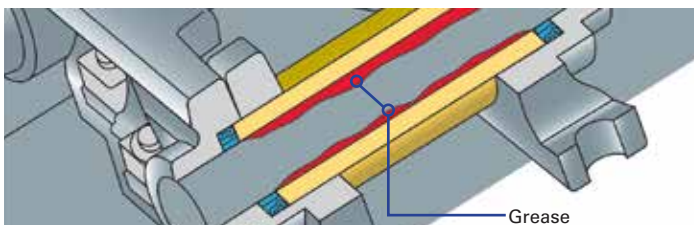

»High rigidity work equipment

»Boom and arms are constructed of thick plates of high tensile strength steel. In addition, these structures are designed with large cross-sectional areas and generous use of castings. The result is working attachments that exhibit long term durability and high resistance to bending and torsional stress.

»Highly reliable electronic devices

»Exclusively designed electronic devices have passed severe testing.

- Controller • Sensors
- Connectors • Heat resistant wiring

»Track link with strut

»PC200-8M0 uses track links with strut, providing superb durability.



OPTIONS



Cab front full height guard level 1 (ISO 10262)



OPG top guard level 2 (ISO 10262)



Additional front lights
Rain visor



Air pre-cleaner



Strengthened track frame undercover



Sun visor



Seat, suspension

KOMATSU BRAND BUCKET

»Komatsu brand bucket for general purpose with wide bucket width

»Me bucket

- Low resistant excavation
- High productivity
- High durability
- High fuel efficiency



Conventional



Me bucket

Category and Feature

Category	Load / Wear / Soil (Application)	Images
Light duty LD	<p>Load Machine power remains low during the majority of the work. No impact load.</p> <p>Wear Material is not abrasive.</p> <p>Soil Dirt, loam and clay.</p>	
General purpose GP	<p>Load Machine power is mostly medium, but occasionally high. Bucket movements are smooth with minor shock load. Bucket penetrates easily.</p> <p>Wear Material is lightly abrasive. Some sand may be medium abrasive.</p> <p>Soil Mostly loose sand, gravel and finely broken materials.</p>	
Heavy duty HD	<p>Load Machine power is high during majority of the work. Medium, but continuous shock load.</p> <p>Wear Material is abrasive. Light scratch marks can be seen at the bucket.</p> <p>Soil Limestone, shot rock, compact mix of sand, gravel and clay.</p>	
Extra heavy duty XHD	<p>Load Machine power is high during most of the work, often at maximum. Dynamic shock loads are frequent and machine may shake.</p> <p>Wear Material is very abrasive. Large scratch marks are visible and, or deform metal. Works within heaps of rock with occasional un-shot rock and rock boulders.</p> <p>Soil Granite, basalt, quartz sand, compact and sticky clay.</p>	

Bucket line-up

Category	Bucket type	Capacity (m ³)	Width* ¹ (mm)	Weight* ² (kg)	Tooth quantity	Boom + arm (m)			Tooth type					
						5.7+1.8	5.7+2.4	5.7+2.9	Vertical	Horizontal	PAB* ³	KMAX	KMAX II	
LD	Conventional	1.17	1,450	940	6	●	●	×	✓	✓				
GP	Conventional	0.50	750	478	3	○	○	○	✓	✓				
		0.80	1,045	635	5	○	○	○	✓	✓				
		0.93	1,200	696	5	□	□	●	✓	✓				
		1.00	1,085	912	5	●	●	■	✓	✓				
		1.05	1,330	757	6	□	□	×	✓	✓				
HD	Conventional	1.20	1,200	939	5	■	■	■	✓	✓				
		Me bucket	0.80	1,045	718	5	○	○	□		✓			
			0.80	1,045	765	5	○	○	□		✓	✓		✓
Me bucket	0.93	1,200	769	5	□	□	●		✓	✓		✓		
	1.05	1,330	938	6	●	●	×	✓	✓	✓		✓		
XHD	Me bucket	1.05	1,330	1,045	6	●	●	×				✓		

*1 Without side cutters *2 With side cutters *3 PAB: Pin and bushing system ○: General purpose use, density up to 1.8 t/m³ □: General purpose use, density up to 1.5 t/m³

●: Light duty work, density up to 1.2 t/m³ ■: Light duty work, density up to 0.9 t/m³ ×: Not usable ✓: Selectable

Feature of [Me bucket] (more suitable shape and effectiveness bucket)

»High productivity by low-resistant excavation

»The new ideal bucket profile produces lower resistance at inside & outside bucket and production will be greatly increased.

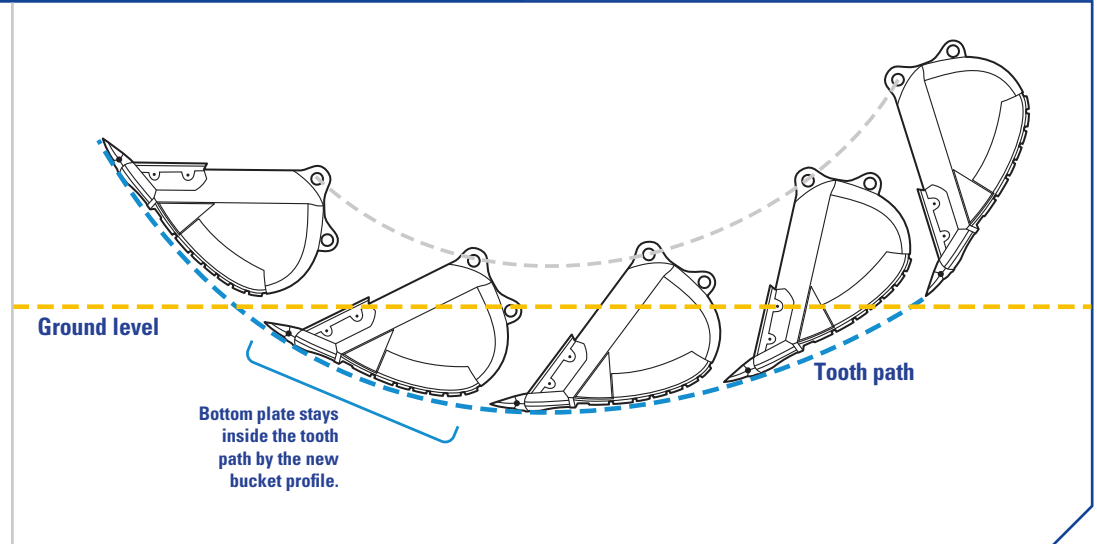

Feature of [PAB tooth] (pin and bushing system tooth)

- Able to fit on the bucket with horizontal pin type adapter
- Easy change-out only with a ratchet wrench
- Longer tooth life by easy rotation and turnover
- Durable and reusable PAB pin with flat surface

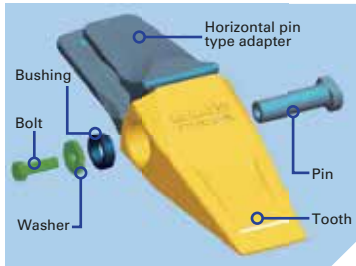

Limited to where horizontal pin type tooth is mainly used.



Set PAB tooth to horizontal pin type adapter.

Insert exclusive pin to the adapter pin hole.

Set bushing, washer and bolt and tighten by a ratchet wrench.

PAB tooth line-up

Type	Style
Integrated long life IL	
Heavy standard HS	
Heavy rock HR	

Feature of [KMAX II] tooth

»Fastener

»Simple, reusable fastener system saves time and money by unlocking with a simple 90-degree turn.

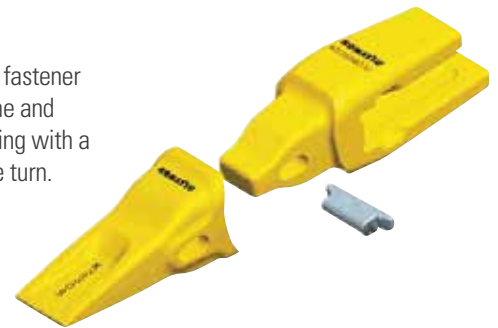

Lock

Unlock

When removing the fastener, use the correct size socket to rotate the pin-locking shaft 90-degree counter-clockwise.







KMAX II tooth line-up

Type	Style
Standard S	
Long Life SL	
Heavy Standard HS	

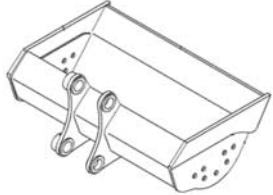
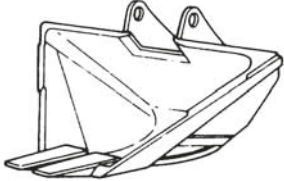
SPECIAL PURPOSE BUCKET & RIPPER

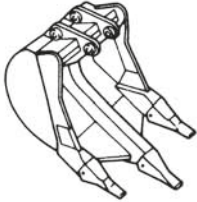
Feature and specifications

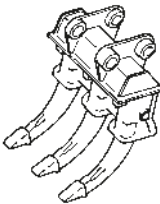
Type	Feature	Bucket capacity (SAE J 296 heaped)	Width	Image
Ditch cleaning bucket	Most suitable for cleaning a river or dredging soft soil from the river bed. The bucket has small holes which allow the water to drain, retaining only solid objects of the ditch.	0.80 m³	1,800 mm	
Trapezoidal bucket	Performs digging and sloping simultaneously on a drainage or irrigation canal. Using this bucket will leave the digging profile shaped as a cross-section.	0.70 m³	—	
Slope finishing bucket	The wide bucket width and flat bottom make this bucket suitable for smoothing the slopes of irrigation canals, roads or river banks.	0.40 m³	2,000 mm	
Ripper bucket	Suitable for digging rock bed or hard clayey soil when normal buckets cannot penetrate deep enough. Loading is also possible.	0.62 m³	990 mm	
Single-shank ripper	This ripper is used for site preparation prior to digging work, when it becomes necessary to remove rocks, pavement for other obstacles. Also effective for pulling out tree stumps.	—	—	
Three-shank ripper	This ripper is an efficient tool for digging up rocks on a slope, digging, crushing and ripping of concrete surfaces, and pulling out tree stumps.	—	—	

HENSLEY BRAND BUCKET



»Diverse bucket capacity by application featuring “KMAX” tooth system

- Wide range selection for each application
- Larger profile and capacity to maximize production
- Multiple width options to meet specific job requirements and reduce backfill

Category and recommended applications

Category	Recommended applications	Image
Trenching and loading TL	Dirt, loam, sand, gravel, loose clay, abrasive soils with limited rock mixture.	
Heavy duty plate lip bucket with wear plate HP	Abrasive soils, compact or dense clay, loose rock and gravel.	
Heavy duty plate lip bucket with wear plate & wear strips HPS	Abrasive soils, compact or dense clay, loose rock and gravel.	
Extreme duty plate lip bucket with special features HPX	Shot rock, stratified materials, quarry or tough, highly abrasive applications.	

Bucket line-up

Category	Capacity (m ³)	Width (mm)	Weight (kg)	Tooth quantity	Boom + arm (m)			Tooth type
					5.7+1.8	5.7+2.4	5.7+2.9	
TL	0.67	762	689	4	○	○	○	✓
	0.85	914	780	5	○	○	○	✓
	1.03	1,067	857	5	○	□	□	✓
	1.20	1,219	949	6	□	●	●	✓
HP	0.50	610	652	3	○	○	○	✓
	0.67	762	763	4	○	○	○	✓
	0.85	914	868	5	○	○	○	✓
	1.03	1,067	950	5	○	□	●	✓
HPS	0.50	610	724	3	○	○	○	✓
	0.67	762	840	4	○	○	○	✓
	0.85	914	962	5	○	○	○	✓
	1.03	1,067	1,061	5	○	□	●	✓
HPX	0.50	610	824	3	○	○	○	✓
	0.67	762	939	4	○	○	○	✓
	0.85	914	1,061	5	○	○	○	✓
	1.03	1,067	1,161	5	□	●	●	✓
HPX	1.20	1,219	1,293	6	●	■	■	✓
	1.38	1,372	1,383	6	■	■	×	✓

○: General purpose use, density up to 1.8 t/m³ □: General purpose use, density up to 1.5 t/m³
 ●: Light duty work, density up to 1.2 t/m³ ■: Light duty work, density: up to 0.9 t/m³
 ×: Not usable ✓: Selectable

Feature of KMAX tooth system

- Better penetration and cycle times
- Hardness throughout the tooth
- Unique high strength design
- Unique reusable fastener
- Less “throw away” waste
- Fast tooth changeover

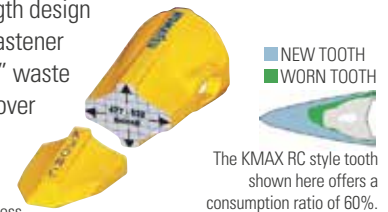

Tooth
 477-532 Brinell level of hardness throughout the tooth.

The KMAX RC style tooth shown here offers a consumption ratio of 60%.

Fastener

Simple, reusable fastener system saves time and money by unlocking with a simple 90-degree turn.



To lock, use the correct size socket, rotate the pin locking shaft 90-degree clockwise to finish the installation.

When removing the fastener, use the correct size socket to rotate the pin-locking shaft 90-degree counter-clockwise.

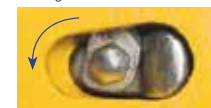

KMAX tooth line-up

Feature	Style
F Flare: Loose material for clean bottom and greater fill	
SYL Standard: General applications	
SD Chisel: General purpose tooth designed for penetration	
RC Rock Chisel: Designed for penetration and long wear life	
T Tiger: Designed for good penetration with ribs for strength	
TV Tiger: Offers best penetration in tight material	
UT Twin Tiger: Offers longer life penetration for corners	
WT Twin Tiger: Designed for penetration for corners	

Some application may not have been available in your country or region. If you are interested in such application, please contact a Komatsu office near you.

SPECIAL SPECS

»Attachment piping specification

»Equips PC200-8M0 for breaker and crusher installation. Hydraulic flow rate can be regulated by setting Breaker Mode on monitor panel during breaker operation.



»Super long front

»Super long front attachment boasts a huge digging reach. An excavator with this attachment highly improves working efficiency in various works such as river conservation, lake dredging, slopefinishing and materials carrying where an extensively long reach is required.



Specifications			
	PC200-8M0	PC200LC-8M0	
Reach	15 m	15 m	18 m
Max. bucket capacity (SAE J 296 heaped)	0.37 m ³	0.45 m ³	0.29 m ³
Boom length	8.6 m	8.6 m	10.3 m
Arm length	6.4 m	6.4 m	8.2 m

ATTACHMENT

Komatsu genuine attachment tool

Komatsu-recommended attachment tools for hydraulic excavators

A wide range of attachment tools are provided to suit customers specific applications.

»Hydraulic breaker

»The hydraulic breaker is an attachment tool used for crushing rock beds and paved surfaces, demolishing concrete structures, etc. The large gas chamber, ideal gas pressure ratio, and long-stroke piston deliver a powerful impact force. Since the breaker unit does not require an accumulator, the number of parts has been reduced, resulting in lower maintenance costs.



»Crusher

»This attachment tool is used for demolishing concrete structures. Since it does not have a striking mechanism and features low noise and low vibration, it is suitable for work in urban areas. The open-close cylinder is equipped with a speed-up valve for increasing work speed.



Primary crusher



Pulverizer



Rotating pulverizer



Applications of attachment tools

Application/ attachment tool	Civil engineering	Quarry	Demolition	Industrial waste disposal	Iron-making	Utility construction	Rental
Hydraulic breaker	○	○	○	○	○	○	○
Crusher (Primary crusher)			○				○
Crusher (Pulverizer)			○	○			○

KOMATSU TOTAL SUPPORT

To keep your machine available and minimize operation cost when you need it, Komatsu Distributor is ready to provide variety of support before and after procuring the machine.



»Fleet recommendation

»Komatsu Distributor can study customer job site and provide the most optimum fleet recommendation with detailed information to meet all of your application needs when you are considering to buy new machines or to replace the existing ones from Komatsu.



»Product support

»Komatsu Distributor secures that a certain quality of machine will be delivered.

»Parts availability

»Komatsu Distributor is available for emergency inquiry by the customers for genuine, quality guaranteed Komatsu parts.

»Technical support

»Komatsu product support service (Technical support) is designed to help customer. Komatsu Distributor offers a variety of effective services, which shows Komatsu's dedication to the maintenance and support of Komatsu equipment.

- Preventive maintenance (PM) clinic
- Oil & wear analysis program
- Undercarriage inspection service, etc.

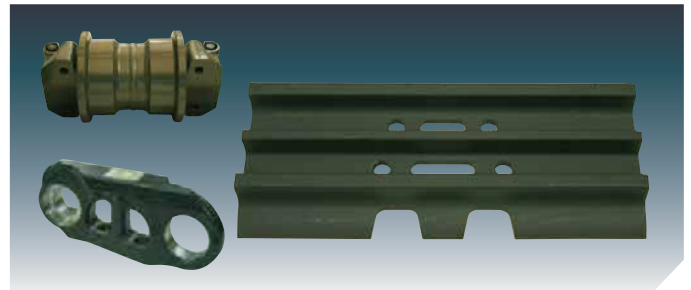

»Repair & maintenance service

»Komatsu Distributor offers quality repair service, periodical maintenance, and maintenance service to the customer, utilizing and promoting Komatsu-developed programs.

»Komatsu Reman (remanufactured) components

»Komatsu Reman products are the result of the implementation of the Komatsu global Reman policy which establishes and agrees to reduce the owning, operating and total Life Cycle Costs (LCC) to Komatsu's customer through prompt delivery, high quality and competitively priced in own remanufactured products (QDC).



SPECIFICATIONS



ENGINE

MODEL	Komatsu SAA6D107E-1.
TYPE	Water-cooled, 4-cycle, direct injection.
ASPIRATION	Turbocharged, aftercooled.
NUMBER OF CYLINDERS	6.
BORE	107 mm.
STROKE	124 mm.
PISTON DISPLACEMENT	6.69 L.
HORSEPOWER:	
SAE J1995	Gross 110 kW 147 hp.
ISO 9249 / SAE J1349	Net 103 kW 138 hp.
RATED RPM	2,000 min ⁻¹ .
FAN DRIVE METHOD FOR RADIATOR COOLING	Mechanical.
GOVERNOR	All-speed control, electronic.



HYDRAULICS

TYPE	HydrauMind (Hydraulic mechanical intelligence new design) system, closed-center system with load sensing valves and pressure compensated valves.
NUMBER OF SELECTABLE WORKING MODES	6.
MAIN PUMP:	
TYPE	Variable displacement piston type.
PUMPS FOR	Boom, arm, bucket, swing, and travel circuits.
MAXIMUM FLOW	439 L/min.
SUPPLY FOR CONTROL CIRCUIT	Self-reducing valve.
HYDRAULIC MOTORS:	
TRAVEL	2 x axial piston motor with parking brake.
SWING	1 x axial piston motor with swing holding brake.
RELIEF VALVE SETTING:	
IMPLEMENT CIRCUITS	37.3 MPa 380 kg/cm ² .
TRAVEL CIRCUIT	37.3 MPa 380 kg/cm ² .
SWING CIRCUIT	28.9 MPa 295 kg/cm ² .
PILOT CIRCUIT	3.2 MPa 33 kg/cm ² .
HYDRAULIC CYLINDERS:	
(NUMBER OF CYLINDERS - BORE X STROKE X ROD DIAMETER)	
BOOM	2-120 mm x 1,334 mm x 85 mm.
ARM	1-135 mm x 1,490 mm x 95 mm.
BUCKET FOR 2.93 M ARM	1-115 mm x 1,120 mm x 80 mm.
FOR 2.41 M ARM	1-115 mm x 1,120 mm x 80 mm.
FOR 1.84 M ARM	1-125 mm x 1,110 mm x 85 mm.



DRIVES AND BRAKES

STEERING CONTROL	Two levers with pedals.
DRIVE METHOD	Hydrostatic.
MAXIMUM DRAWBAR PULL	178 kN 18,200 kg.
GRADEABILITY	70%, 35°.
MAXIMUM TRAVEL SPEED: HIGH	5.5 km/h.
(AUTO-SHIFT) MID	4.1 km/h.
(AUTO-SHIFT) LOW	3.0 km/h.
SERVICE BRAKE	Hydraulic lock.
PARKING BRAKE	Mechanical disc brake.



SWING SYSTEM

DRIVE METHOD	Hydrostatic.
SWING REDUCTION	Planetary gear.
SWING CIRCLE LUBRICATION	Grease-bathed.
SERVICE BRAKE	Hydraulic lock.
HOLDING BRAKE/SWING LOCK	Mechanical disc brake.
SWING SPEED	12.4 min ⁻¹ .



UNDERCARRIAGE

CENTER FRAME	X-frame.
TRACK FRAME	Box-section.
SEAL OF TRACK	Sealed track.
TRACK ADJUSTER	Hydraulic.
NUMBER OF SHOES (EACH SIDE):	
PC200-8M0	45.
PC200LC-8M0	49.
NUMBER OF CARRIER ROLLERS	2 each side.
NUMBER OF TRACK ROLLERS (EACH SIDE):	
PC200-8M0	7.
PC200LC-8M0	9.



COOLANT AND LUBRICANT CAPACITY (REFILLING)

FUEL TANK	400 L.
COOLANT	20.4 L.
ENGINE	23.1 L.
FINAL DRIVE (EACH SIDE)	3.6 L.
SWING DRIVE	6.5 L.
HYDRAULIC TANK	135 L.



OPERATING WEIGHT (APPROXIMATE)

Operating weight including 5,700 mm one-piece boom, 2,925 mm arm, SAE J 296 heaped 0.80 m³ backhoe bucket, rated capacity of lubricants, coolant, full fuel tank, operator, and standard equipment.

Shoes	PC200-8M0		PC200LC-8M0	
	Operating weight	Ground pressure	Operating weight	Ground pressure
500 mm	19,800 kg	54.9 kPa 0.56 kg/cm ²	—	—
600 mm	19,900 kg	46.1 kPa 0.47 kg/cm ²	20,700 kg	43.1 kPa 0.44 kg/cm ²
700 mm	20,200 kg	40.2 kPa 0.41 kg/cm ²	21,100 kg	37.2 kPa 0.38 kg/cm ²
800 mm	20,500 kg	35.3 kPa 0.36 kg/cm ²	21,400 kg	33.3 kPa 0.34 kg/cm ²
900 mm	—	—	21,700 kg	30.4 kPa 0.31 kg/cm ²



DIMENSIONS

Arm length		1,840 mm	2,410 mm	2,925 mm
A	Overall length	9,480 mm	9,495 mm	9,425 mm
B	Length on ground (transport): PC200-8M0 PC200LC-8M0	6,270 mm	5,700 mm	4,815 mm
		6,455 mm	5,885 mm	5,000 mm
C	Overall height (to top of boom)	2,985 mm	3,190 mm	2,970 mm

	PC200-8M0	PC200LC-8M0	
D	Overall width	2,800 mm	3,080 mm
E	Overall height (to top of cab)	3,040 mm	3,040 mm
F	Ground clearance, counterweight	1,085 mm	1,085 mm
G	Ground clearance (minimum)	440 mm	440 mm
H	Tail swing radius	2,750 mm	2,750 mm
I	Track length on ground	3,275 mm	3,655 mm
J	Track length	4,070 mm	4,450 mm
K	Track gauge	2,200 mm	2,380 mm
L	Width of crawler	2,800 mm	3,080 mm
M	Shoe width	600 mm	700 mm
N	Grouser height	26 mm	26 mm
O	Machine cab height	2,095 mm	2,095 mm
P	Machine cab width	2,710 mm	2,710 mm
Q	Distance, swing center to rear end	2,710 mm	2,710 mm

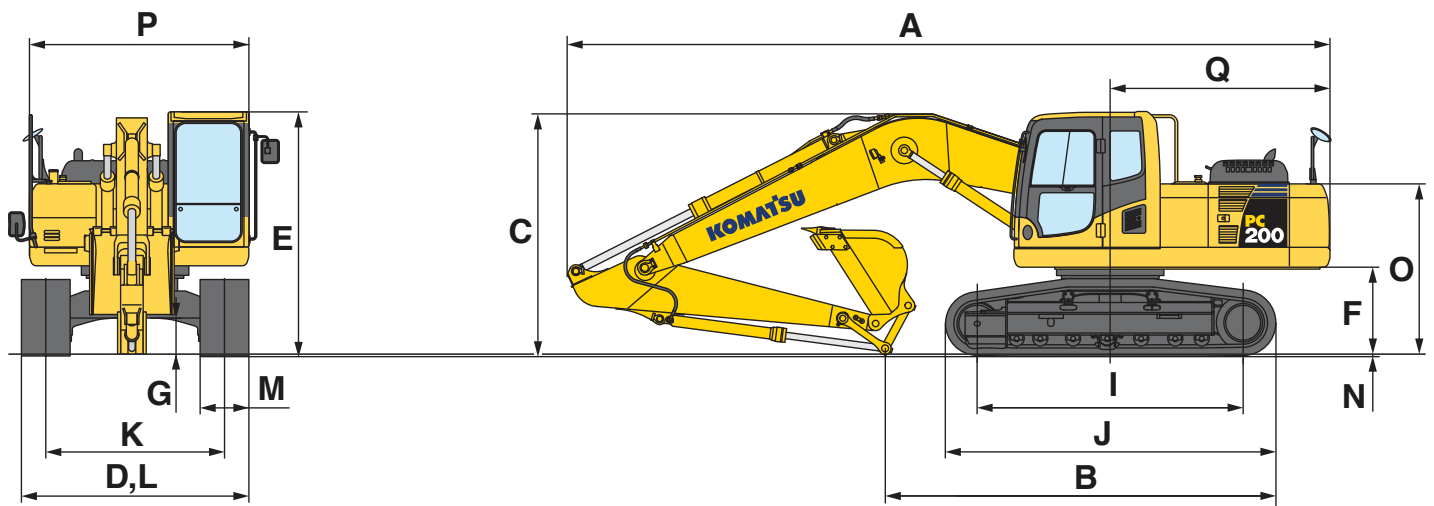
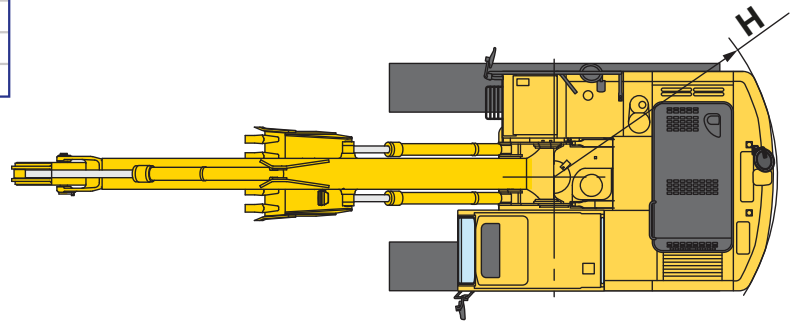



WORKING RANGE

Arm length		1,840 mm	2,410 mm	2,925 mm
A	Max. digging height	9,500 mm	9,800 mm	10,000 mm
B	Max. dumping height	6,630 mm	6,890 mm	7,110 mm
C	Max. digging depth	5,380 mm	6,095 mm	6,620 mm
D	Max. vertical wall digging depth	4,630 mm	5,430 mm	5,980 mm
E	Max. digging depth of cut for 2,440 mm level	5,130 mm	5,780 mm	6,370 mm
F	Max. digging reach	8,850 mm	9,380 mm	9,875 mm
G	Max. digging reach at ground level	8,660 mm	9,190 mm	9,700 mm
H	Min. swing radius	3,010 mm	3,090 mm	3,040 mm
SAE J 1179 rating	Bucket digging force at power max.	157 kN 16,000 kg	138 kN 14,100 kg	138 kN 14,100 kg
	Arm crowd force at power max.	139 kN 14,200 kg	124 kN 12,600 kg	101 kN 10,300 kg
ISO 6015 rating	Bucket digging force at power max.	177 kN 18,000 kg	149 kN 15,200 kg	149 kN 15,200 kg
	Arm crowd force at power max.	145 kN 14,800 kg	127 kN 13,000 kg	108 kN 11,000 kg

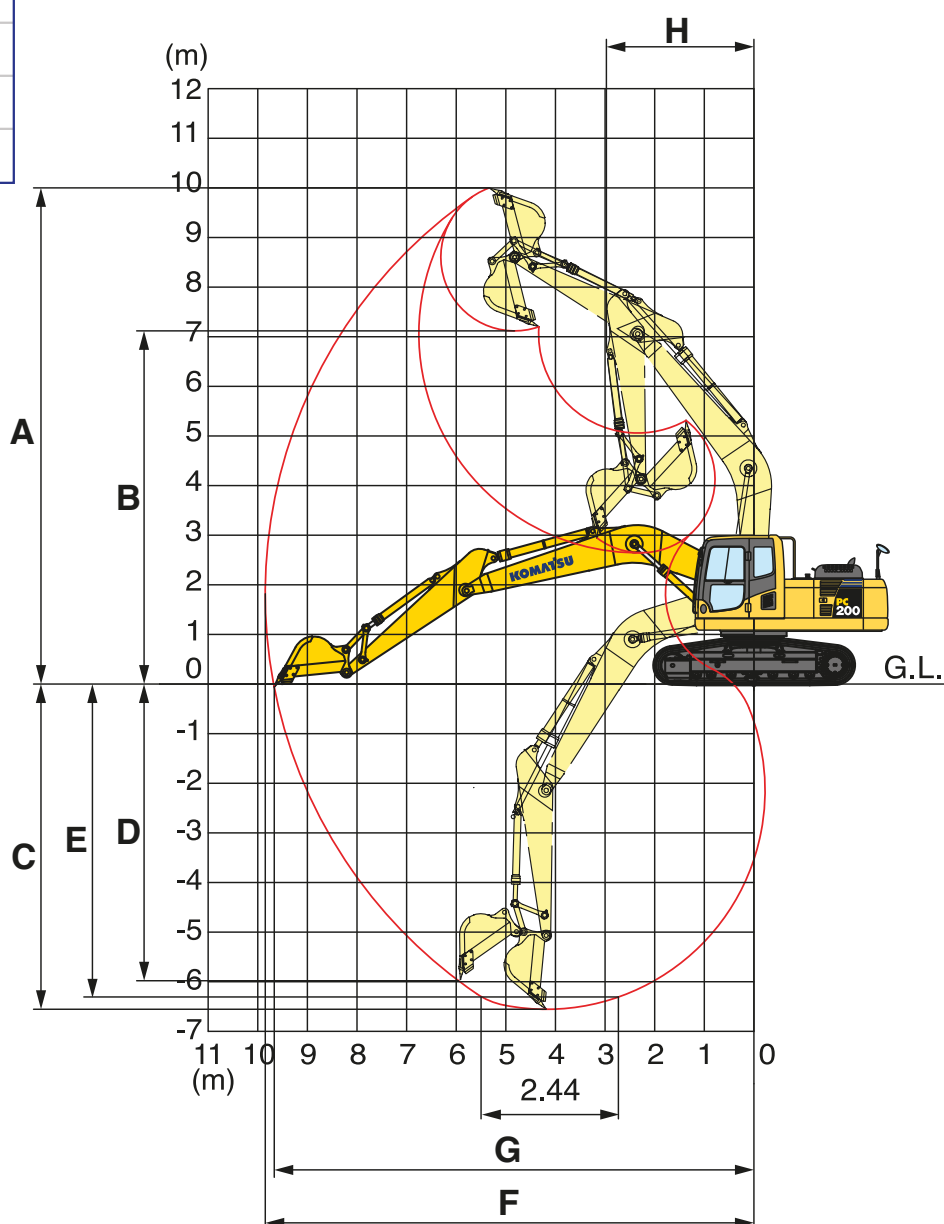

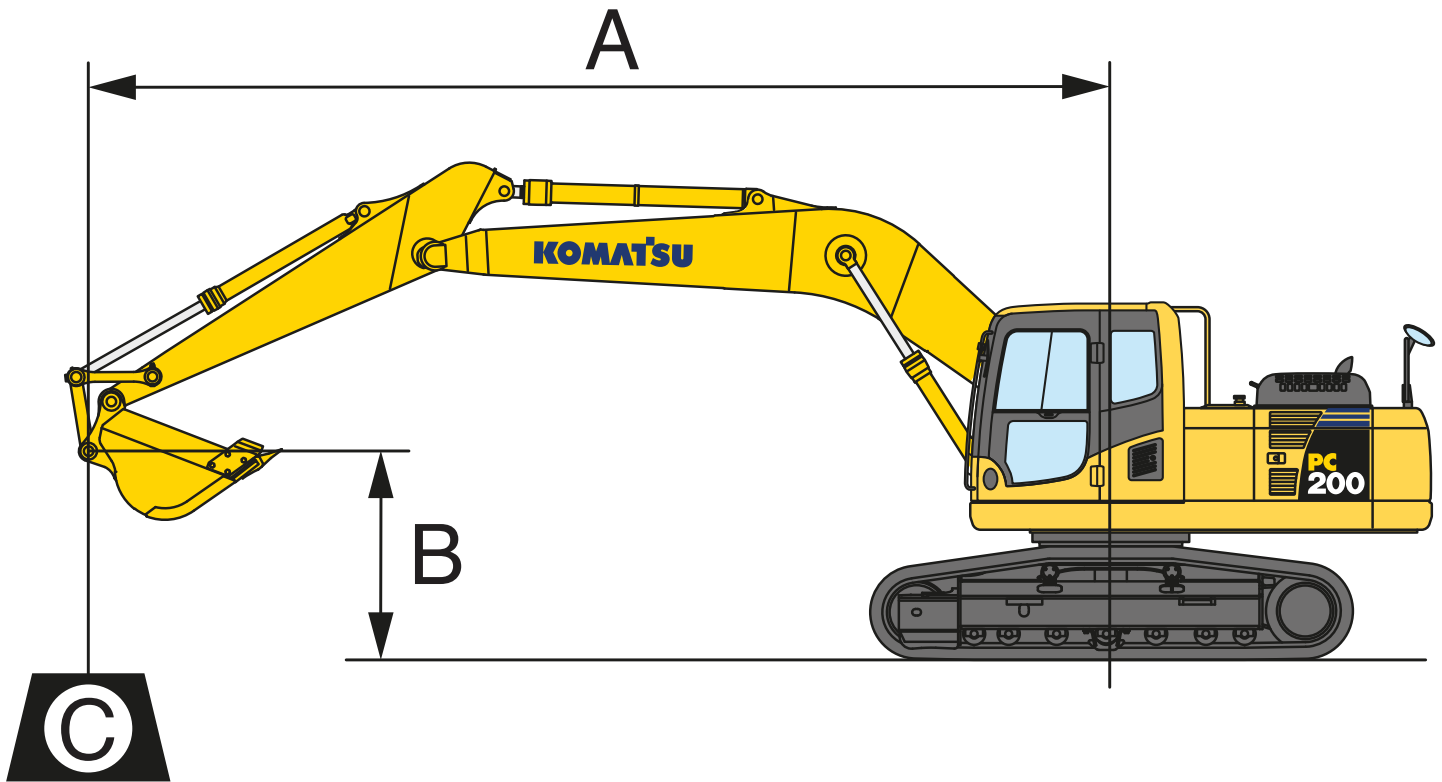

- A: Reach from swing center.
- B: Bucket hook height.
- C: Lifting capacity.
- Cf: Rating over front.
- Cs: Rating over side.
- ⊗ : Rating at maximum reach.

Conditions:

- 5,700 mm one-piece boom.
- 0.8 m³ SAE J 296 heaped bucket.
- Shoe width: —PC200-8M0 600 mm triple grouser.



LIFTING CAPACITY WITH LIFTING MODE

PC200-8M0		Arm: 1,840 mm		Bucket: 0.8 m ³ SAE J 296 heaped		Shoe: 600 mm triple grouser							
B	A	MAX		7.5 m		6.0 m		4.5 m		3.0 m		1.5 m	
		Cf	Cs	Cf	Cs	Cf	Cs	Cf	Cs	Cf	Cs	Cf	Cs
7.5 m		*5,100 kg	*5,100 kg					*5,600 kg	*5,600 kg				
6.0 m		*4,800 kg	3,600 kg			*5,550 kg	3,950 kg	*5,800 kg	*5,800 kg				
4.5 m		4,400 kg	2,850 kg			5,850 kg	3,800 kg	*7,350 kg	6,150 kg	*10,350 kg	*10,350 kg		
3.0 m		3,900 kg	2,500 kg	3,850 kg	2,450 kg	5,600 kg	3,600 kg	9,000 kg	5,650 kg				
1.5 m		3,750 kg	2,350 kg	3,750 kg	2,350 kg	5,400 kg	3,400 kg	8,550 kg	5,200 kg				
0 m		3,900 kg	2,400 kg	3,700 kg	2,300 kg	5,250 kg	3,250 kg	8,350 kg	5,050 kg				
-1.5 m		4,400 kg	2,750 kg			5,200 kg	3,250 kg	8,350 kg	5,050 kg	*9,500 kg	*9,500 kg		
-3.0 m		5,750 kg	3,600 kg			5,350 kg	3,350 kg	8,500 kg	5,200 kg	*13,000 kg	10,300 kg		

PC200-8M0		Arm: 2,410 mm		Bucket: 0.8 m ³ SAE J 296 heaped		Shoe: 600 mm triple grouser							
B	A	MAX		7.5 m		6.0 m		4.5 m		3.0 m		1.5 m	
		Cf	Cs	Cf	Cs	Cf	Cs	Cf	Cs	Cf	Cs	Cf	Cs
7.5 m		*4,500 kg	4,250 kg										
6.0 m		*4,250 kg	3,000 kg			*4,850 kg	4,050 kg						
4.5 m		3,800 kg	2,450 kg	4,000 kg	2,600 kg	*5,450 kg	3,900 kg	*6,400 kg	6,300 kg				
3.0 m		3,450 kg	2,150 kg	3,900 kg	2,500 kg	5,650 kg	3,650 kg	*8,650 kg	5,800 kg				
1.5 m		3,300 kg	2,050 kg	3,750 kg	2,350 kg	5,450 kg	3,450 kg	8,650 kg	5,300 kg				
0 m		3,400 kg	2,100 kg	3,700 kg	2,300 kg	5,250 kg	3,250 kg	8,350 kg	5,050 kg	*7,000 kg	*7,000 kg		
-1.5 m		3,750 kg	2,350 kg	3,650 kg	2,250 kg	5,200 kg	3,200 kg	8,300 kg	5,000 kg	*9,300 kg	*9,300 kg	*7,700 kg	*7,700 kg
-3.0 m		4,650 kg	2,900 kg			5,250 kg	3,250 kg	8,400 kg	5,100 kg	*14,600 kg	10,200 kg		
-4.5 m		*7,150 kg	4,500 kg					*8,300 kg	5,350 kg	*11,650 kg	10,400 kg		

PC200-8M0		Arm: 2,925 mm		Bucket: 0.8 m ³ SAE J 296 heaped		Shoe: 600 mm triple grouser							
B	A	MAX		7.5 m		6.0 m		4.5 m		3.0 m		1.5 m	
		Cf	Cs	Cf	Cs	Cf	Cs	Cf	Cs	Cf	Cs	Cf	Cs
7.5 m		*2,900 kg	*2,900 kg			*4,050 kg	*4,050 kg						
6.0 m		*2,750 kg	2,600 kg	*3,100 kg	2,600 kg	*4,250 kg	4,100 kg						
4.5 m		*2,750 kg	2,150 kg	4,000 kg	2,550 kg	*4,850 kg	3,900 kg	*5,500 kg	*5,500 kg				
3.0 m		*2,900 kg	1,900 kg	3,850 kg	2,450 kg	5,650 kg	3,650 kg	*7,700 kg	5,850 kg	*11,600 kg	11,450 kg		
1.5 m		2,950 kg	1,800 kg	3,700 kg	2,300 kg	5,400 kg	3,400 kg	8,700 kg	5,300 kg	*6,800 kg	*6,800 kg		
0 m		3,000 kg	1,800 kg	3,600 kg	2,200 kg	5,150 kg	3,200 kg	8,300 kg	4,950 kg	*5,150 kg	*5,150 kg		
-1.5 m		3,300 kg	2,000 kg	3,550 kg	2,150 kg	5,050 kg	3,050 kg	8,100 kg	4,850 kg	*9,300 kg	*9,300 kg	*5,150 kg	*5,150 kg
-3.0 m		3,950 kg	2,400 kg			5,050 kg	3,100 kg	8,200 kg	4,900 kg	*14,800 kg	9,850 kg	*9,700 kg	*9,700 kg
-4.5 m		5,700 kg	3,500 kg					8,400 kg	5,100 kg	*12,950 kg	10,200 kg		

* Load is limited by hydraulic capacity rather than tipping. Ratings are based on SAE J1097. Rated loads do not exceed 87% of hydraulic lift capacity or 75% of tipping load.

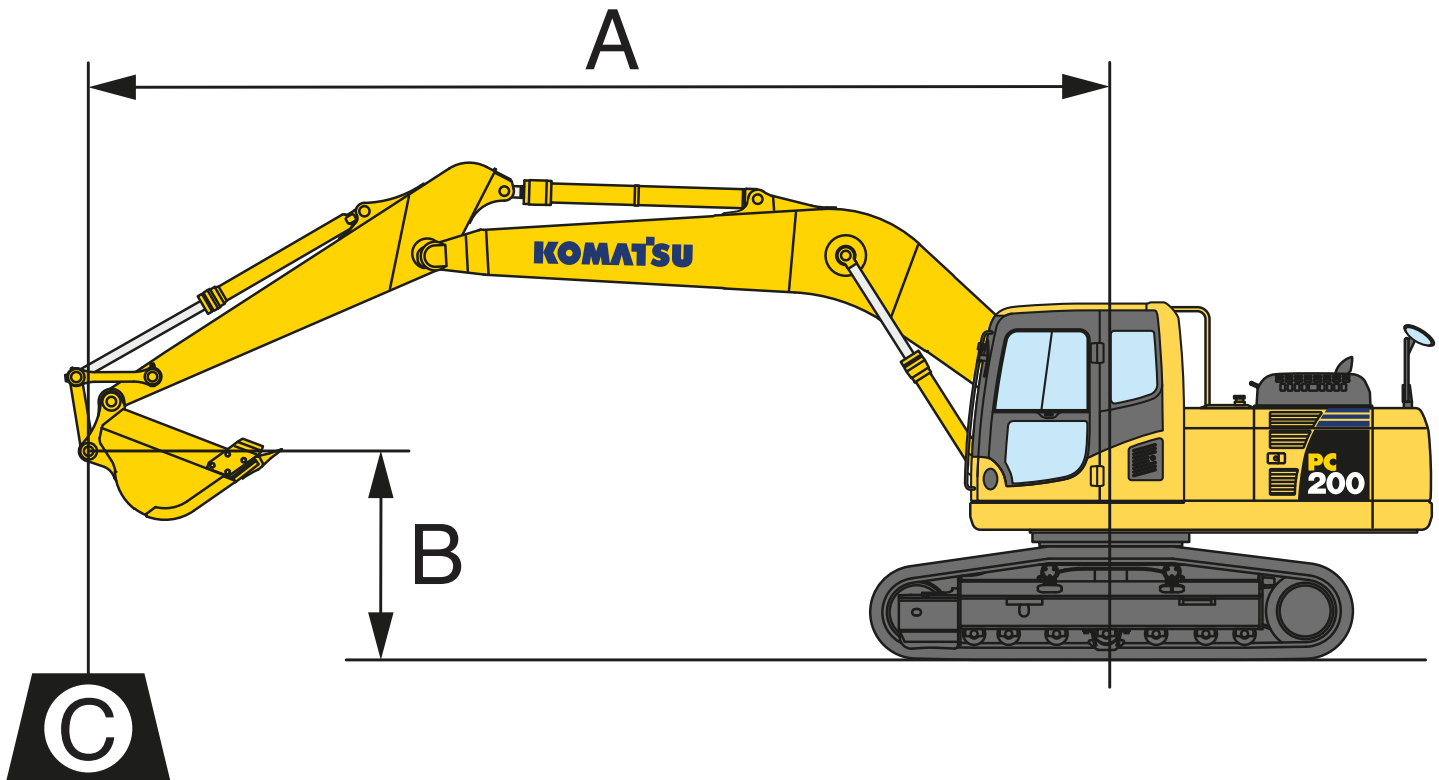

- A: Reach from swing center.
- B: Bucket hook height.
- C: Lifting capacity.
- Cf: Rating over front.
- Cs: Rating over side.
- ⊗ : Rating at maximum reach.

Conditions:

- 5,700 mm one-piece boom.
- 0.8 m³ SAE J 296 heaped bucket.
- Shoe width: —PC200LC-8M0 700 mm triple grouser.



LIFTING CAPACITY WITH LIFTING MODE

PC200LC-8M0 Arm: 1,840 mm Bucket: 0.8 m ³ SAE J 296 heaped Shoe: 700 mm triple grouser													
B	A	MAX		7.5 m		6.0 m		4.5 m		3.0 m		1.5 m	
		Cf	Cs	Cf	Cs	Cf	Cs	Cf	Cs	Cf	Cs	Cf	Cs
7.5 m		*5,100 kg	*5,100 kg					*5,600 kg	*5,600 kg				
6.0 m		*4,800 kg	4,150 kg			*5,550 kg	4,550 kg	*5,800 kg	*5,800 kg				
4.5 m		*4,900 kg	3,300 kg	4,750 kg	2,900 kg	*6,000 kg	4,400 kg	*7,350 kg	7,050 kg	*10,350 kg	*10,350 kg		
3.0 m		4,850 kg	2,900 kg	4,650 kg	2,800 kg	6,900 kg	4,200 kg	*9,700 kg	6,550 kg				
1.5 m		4,650 kg	2,800 kg	4,600 kg	2,750 kg	6,700 kg	4,000 kg	*10,700 kg	6,100 kg				
0 m		4,850 kg	2,850 kg			6,550 kg	3,850 kg	10,600 kg	5,950 kg				
-1.5 m		5,450 kg	3,250 kg			6,500 kg	3,800 kg	*10,600 kg	5,950 kg	*9,500 kg	*9,500 kg		
-3.0 m		7,150 kg	4,200 kg			6,650 kg	3,950 kg	*9,750 kg	6,100 kg	*13,000 kg	12,250 kg		

PC200LC-8M0 Arm: 2,410 mm Bucket: 0.8 m ³ SAE J 296 heaped Shoe: 700 mm triple grouser													
B	A	MAX		7.5 m		6.0 m		4.5 m		3.0 m		1.5 m	
		Cf	Cs	Cf	Cs	Cf	Cs	Cf	Cs	Cf	Cs	Cf	Cs
7.5 m		*4,500 kg	*4,500 kg										
6.0 m		*4,250 kg	3,500 kg			*4,850 kg	4,650 kg						
4.5 m		*4,300 kg	2,850 kg	4,900 kg	3,000 kg	*5,450 kg	4,500 kg	*6,400 kg	*6,400 kg				
3.0 m		4,250 kg	2,550 kg	4,800 kg	2,900 kg	*6,400 kg	4,200 kg	*8,650 kg	6,750 kg				
1.5 m		4,100 kg	2,450 kg	4,700 kg	2,800 kg	6,750 kg	4,000 kg	*10,550 kg	6,250 kg				
0 m		4,250 kg	2,500 kg	4,600 kg	2,700 kg	6,550 kg	3,850 kg	10,650 kg	5,950 kg	*7,000 kg	*7,000 kg		
-1.5 m		4,700 kg	2,750 kg	4,550 kg	2,700 kg	6,500 kg	3,800 kg	10,550 kg	5,900 kg	*9,300 kg	*9,300 kg	*7,700 kg	*7,700 kg
-3.0 m		5,800 kg	3,400 kg			6,550 kg	3,850 kg	*10,350 kg	6,000 kg	*14,600 kg	12,200 kg		
-4.5 m		*7,150 kg	5,250 kg					*8,300 kg	6,250 kg	*11,650 kg	*11,650 kg		

PC200LC-8M0 Arm: 2,925 mm Bucket: 0.8 m ³ SAE J 296 heaped Shoe: 700 mm triple grouser													
B	A	MAX		7.5 m		6.0 m		4.5 m		3.0 m		1.5 m	
		Cf	Cs	Cf	Cs	Cf	Cs	Cf	Cs	Cf	Cs	Cf	Cs
7.5 m		*2,900 kg	*2,900 kg			*4,050 kg	*4,050 kg						
6.0 m		*2,750 kg	*2,750 kg	*3,100 kg	3,050 kg	*4,250 kg	*4,250 kg						
4.5 m		*2,750 kg	2,550 kg	*4,600 kg	3,000 kg	*4,850 kg	4,500 kg	*5,500 kg	*5,500 kg				
3.0 m		*2,900 kg	2,250 kg	4,800 kg	2,850 kg	*5,900 kg	4,200 kg	*7,700 kg	6,800 kg	*11,600 kg	*11,600 kg		
1.5 m		*3,200 kg	2,150 kg	4,600 kg	2,750 kg	6,700 kg	3,950 kg	*9,800 kg	6,250 kg	*6,800 kg	*6,800 kg		
0 m		*3,700 kg	2,200 kg	4,500 kg	2,600 kg	6,500 kg	3,750 kg	10,550 kg	5,850 kg	*5,150 kg	*5,150 kg		
-1.5 m		4,150 kg	2,400 kg	4,450 kg	2,550 kg	6,350 kg	3,650 kg	10,400 kg	5,750 kg	*9,300 kg	*9,300 kg	*5,150 kg	*5,150 kg
-3.0 m		4,950 kg	2,900 kg			6,350 kg	3,650 kg	*10,400 kg	5,800 kg	*14,800 kg	11,800 kg	*9,700 kg	*9,700 kg
-4.5 m		*6,700 kg	4,100 kg					*9,100 kg	6,000 kg	*12,950 kg	*12,000 kg		

* Load is limited by hydraulic capacity rather than tipping. Ratings are based on SAE J1097. Rated loads do not exceed 87% of hydraulic lift capacity or 75% of tipping load.



STANDARD EQUIPMENT

»ENGINE:

- »Automatic engine warm-up system.
- »Dry type air cleaner, double element.
- »Engine, Komatsu SAA6D107E-1.
- »Engine overheat prevention system.
- »Radiator and oil cooler dust proof net.
- »Suction fan.

»ELECTRICAL SYSTEM:

- »Alternator, 24 V/35 A.
- »Auto-decelerator.
- »Batteries, 2 X 12 V/110 Ah.
- »Starting motor, 24 V/4.5 kW.
- »Working light, 2 (boom and RH).

»HYDRAULIC SYSTEM:

- »Boom holding valve.
- »Power maximizing system.
- »Pressure proportional control (PPC) hydraulic control system.
- »Working mode selection system.

»GUARDS AND COVERS:

- »Fan guard structure.
- »Track guiding guard, center section.

»UNDERCARRIAGE:

- »Hydraulic track adjusters (each side).
- »Track roller.
- PC200-8M0, 7 each side.
- PC200LC-8M0, 9 each side.
- »Track shoe.
- PC200-8M0, 600 mm triple grouser.
- PC200LC-8M0, 700 mm triple grouser.

»OPERATOR ENVIRONMENT:

- »Equipment management monitoring system.
- »Large multi-lingual high resolution LCD monitor.
- »Rear view mirrors (RH, LH, rear, sidewise).
- »ROPS cab (ISO 12117-2).

»OTHER EQUIPMENT:

- »Counterweight.
- »Electric horn.
- »Rear reflector.
- »Slip-resistant plates.
- »Travel alarm.



OPTIONAL EQUIPMENT

»ENGINE:

- »Additional filter system for poor-quality fuel (water separator).
- »Air pre-cleaner.
- »Large capacity fuel pre-filter.

»ELECTRICAL SYSTEM:

- »Alternator, 24 V/60 A.
- »Batteries, large capacity.
- »Working lights.
- 2 on cab.
- 1 on counterweight.

»HYDRAULIC SYSTEM:

- »Long lubricating intervals for work equipment bushing (500 hours).
- »Service valve.

»UNDERCARRIAGE:

- »Shoes, triple grouser shoes.
- PC200-8M0 500 mm, 700 mm, 800 mm.
- PC200LC-8M0 600 mm, 800 mm, 900 mm.
- »Track frame undercover.
- »Track roller guards (full length).

»OPERATOR ENVIRONMENT:

- »A/C with defroster.
- »Bolt-on top guard, OPG top guard level 2 (ISO 10262).
- »Cab accessories.
- Rain visor.
- Sun visor.
- »Cab front guard.
- Full height guard.
- Half height guard.

- »Heater with defroster.
- »Rear view monitor system.
- »Seat belt, retractable.
- »Seat, suspension.

»WORK EQUIPMENT:

- »Arms.
- 1,840 mm arm assembly.
- 2,410 mm arm assembly.
- 2,925 mm arm assembly.
- »Boom 5,700 mm.

**Optional equipment may not be available in your country.
Please contact your Distributor for further information.**

Product designs, specifications and/or data in this document are provided for informational purposes only and are not warranties of any kind. Product designs and/or specifications may be changed at any time without notice. The only warranties that apply to sales of products and services are standard written warranties, which will be furnished upon request.

Komatsu, and related logo are trademarks of Komatsu Ltd. or one of its affiliates.

© 2017 Komatsu Ltd. or one of its affiliates. All rights reserved.

KOMATSU[®]

For further information, contact your distributor or visit our website www.komatsulatioamerica.com

KLAT-EQ028/001-2018

