

SHORT SHARP TRAINING (monthly) issue 1210

Welcome to this issue of the Vectorworks Short Sharp Training (monthly). This manual is designed to work like a user group meeting. There is a main workshop topic, then extended movies showing tips or techniques and an area for beginners.

Workshop Topic

Stairs

There are a few different Stair tools. Each one is used for different situations, or stages of the design. We look at the different tools and techniques for creating stairs.

© 2012 Jonathan Pickup - Archoncad

All rights reserved. No part of this book may be reproduced or transmitted in any form by any means, electronic or mechanical, including photocopying, recording, faxing, emailing, posting online or by any information storage and retrieval system, without prior written permission of the publisher.

Vectorworks is a registered trademark of Nemetschek Vectorworks Inc. in the U.S. and other countries. Windows is a registered trademark of Microsoft Corporation in the U.S. and other countries.

Macintosh is a trademark of Apple Computer, Inc., registered in the U.S. and other countries. Adobe, Acrobat and Reader are registered trademarks of Adobe Systems in the U.S. and other countries.

The information in this book is distributed on an “as is” basis, without warranty. While every precaution has been taken in the preparation of this book, the author shall not have any liability to any person or entity with respect to any loss or damage caused or alleged to be caused directly or indirectly by the information contained in this book or by the computer software described in it.

For more Vectorworks training information, or to purchase more copies of this book, please email jon@archoncad.co.nz

Contents

Introduction..... 4

Simple Stair..... 5

 Stair with Landing..... 11

 Landing Left or Right..... 12

 Double Back Stair (Dog-leg Stairs)..... 15

Circular Stair 21

Custom Stair..... 23

 Straight Stair 23

 Other Stair Options 34

Stair Tool - Straight Stair 47

 Stair Tool - Stair with Landing..... 62

 Stair Tool - U-Stair (Dog-leg Stair)..... 67

 When to Use the Stair Tool 75

Introduction

There are a range of tools for creating stairs and ramps. Not all the tools are available for all the professions. For example, the Simple Stair tool is available on the Fundamentals workspace, the Landmark workspace, but not on the Architect workspace. The Custom Stair tool is available on the Architect and Landmark workspaces, but not on the Fundamentals workspace.

The Architect workspace has a very powerful but complex stair tool, which we will look at in detail. But should you use this complex tool at the conceptual stage of your design?

Simple Stair

[cadmovie869](#)

The Simple Stair tool can be used to create your stairs at concept stage. This tool is only available on the Landmark and Fundamentals workspaces. But if you want a fast simple stair, then this is the tool to use.

But remember, it is a simple stair, so it will be limited. This tool was introduced in Vectorworks 2010. If you have an earlier version of Vectorworks, you will not have this tool.

- If you are using the Landmark workspace, you will find this tool on the **Building Shell** tool set.

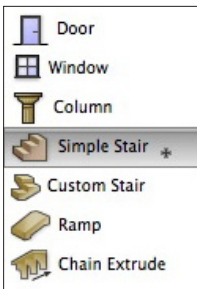

- If you are using the Fundamentals workspace, you will find this tool on the **Walls** tool set.



- Go to the **Tool bar**.

- Click on the **Preferences...** button.

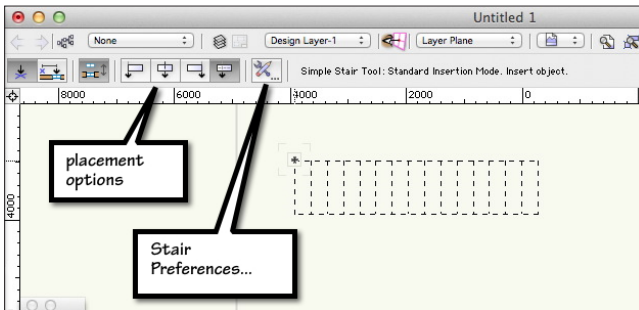

- These are the settings for the stair.

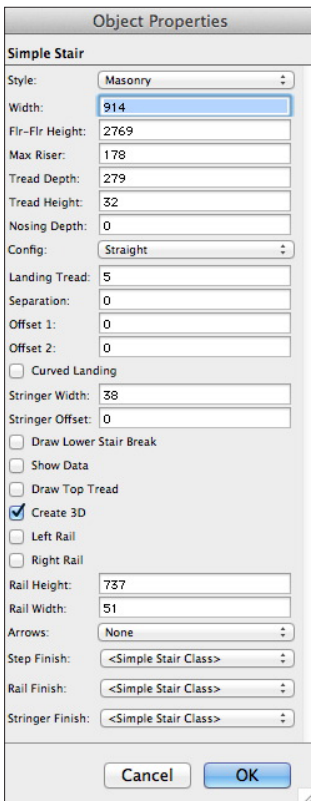

- Choose the style of the stair, using the **Style** pop-up menu. You can choose from Standard, Indented, Open Riser, or Masonry.

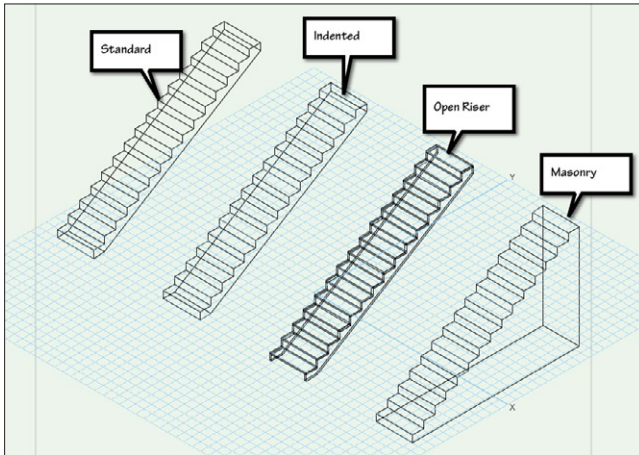

- Type in the settings you want for the width, height, configuration, and so on.
- Ensure that you set the classes for the components of the stairs.

Object Properties

Simple Stair

Style: Standard ▾

Width: 900

Flr-Flr Height: 2900

Max Riser: 171

Tread Depth: 280

Tread Height: 25

Nosing Depth: 25

Config: Straight ▾

Landing Tread: 5

Separation: 0

Offset 1: 0

Offset 2: 0

Curved Landing

Stringer Width: 38

Stringer Offset: 0

Draw Lower Stair Break

Show Data

Draw Top Tread

Create 3D

Left Rail

Right Rail

Rail Height: 850

Rail Width: 40

Arrows: Up ▾

Step Finish: Interior-Joinery-Stairs-Treads ▾

Rail Finish: Interior-Joinery-Stairs-Han... ▾

Stringer Finish: Interior-Joinery-Stairs-Stri... ▾

- You can either fill out the parameter before you place the stair or you can place the stair and then go to the Object Info Palette and change the settings.

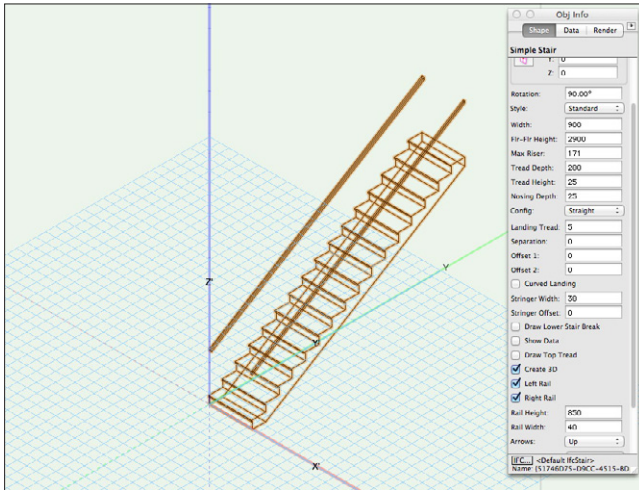

- This what the Tread and Riser relate to.

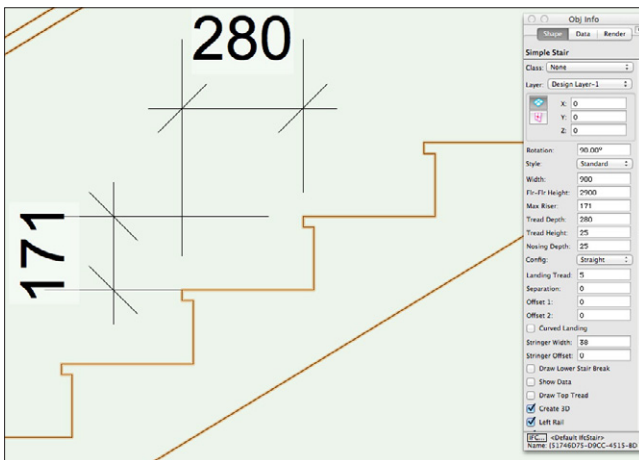

- Click on the **OK** button when you have completed setting the preferences you want.
- Go to the **Tool** bar.
- Choose the Placement options to suit the stair.

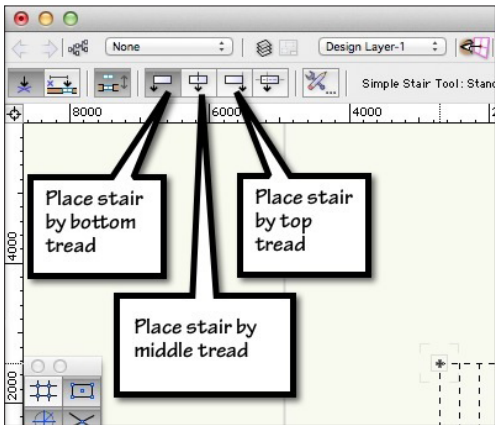

- Click once in the drawing to place the insertion point of the stair.

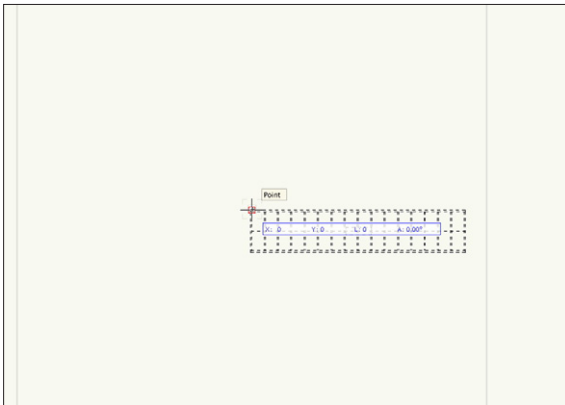

- Click once again to set the rotation of the stair, and complete the placement.

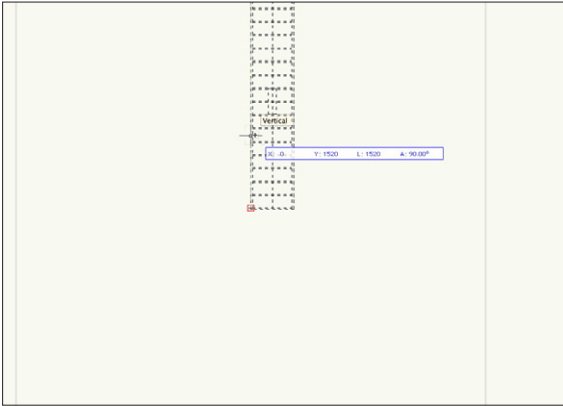

You can make a wide range of stairs with this simple tool, which is way I say that you could use it at the concept stage.

Stair with Landing

- On the Object Info Palette you can change the stair configuration to Straight With Landing.

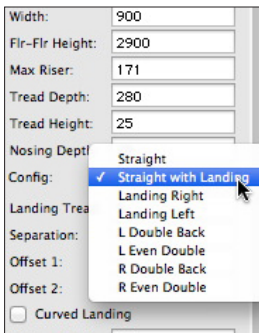

- There is a field to fill out the landing tread. This is the number of treads up from the bottom to the landing.

| | |
|-----------------------------------------|------------------|
| Max Riser: | 171 |
| Tread Depth: | 280 |
| Tread Height: | 25 |
| Nosing Depth: | 25 |
| Config: | Straight wi... ▾ |
| Landing Tread: | 8 |
| Separation: | 0 |
| Offset 1: | 0 |
| Offset 2: | 0 |
| <input type="checkbox"/> Curved Landing | |

This image shows the stair with the settings.

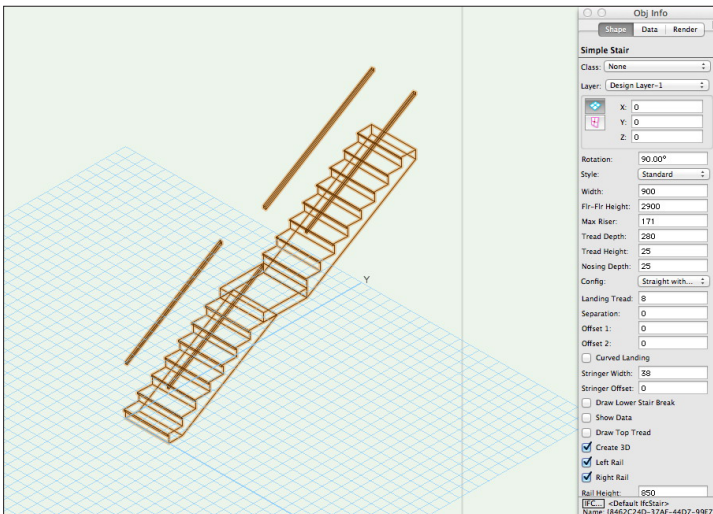

Landing Left or Right

- The Landing Left or Landing Right stair can be used to create a corner stair, or a stair that finishes on a landing.

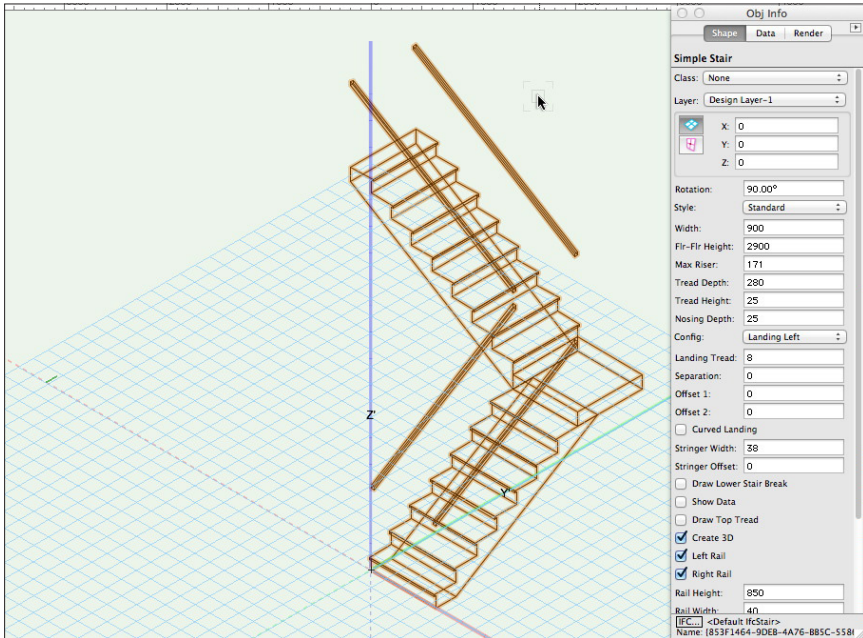

- You can create a stair with a landing at the bottom. To do this you set the landing tread to 1. This will make the first tread the landing. The offsets can be used to set the start of the tread a specific distance from the corner, as you would want to.

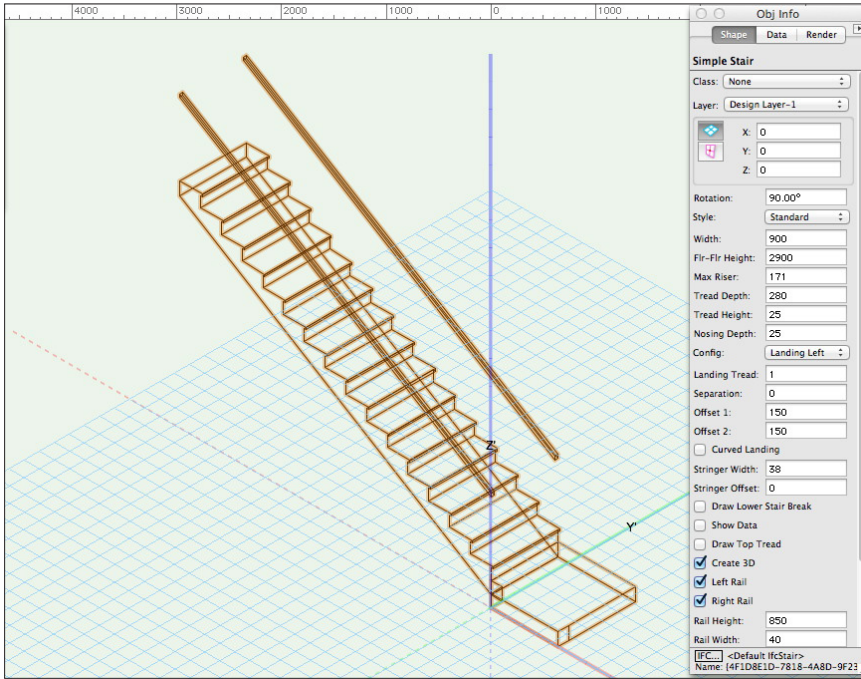

Landing Right

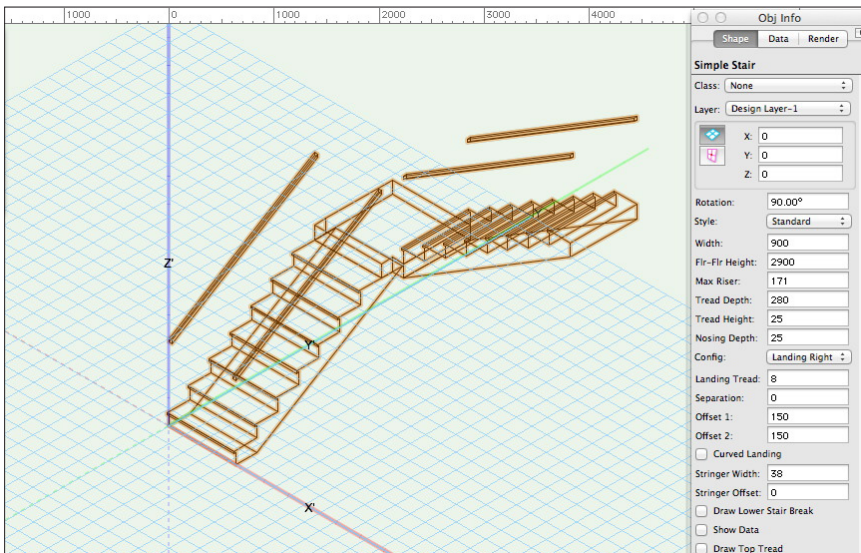

Double Back Stair (Dog-leg Stairs)

- The Double Back is used to create dog-leg stairs.

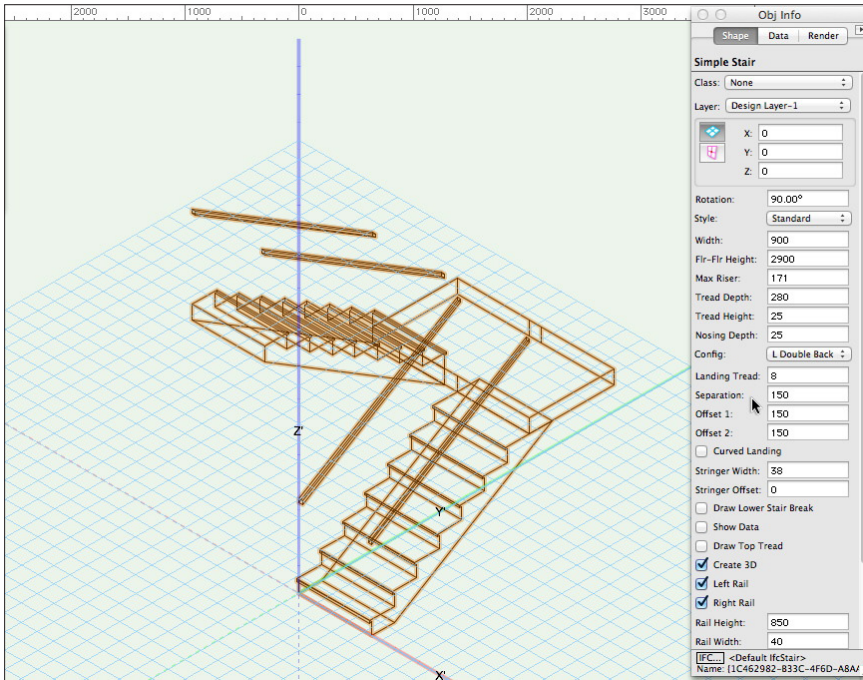

- You can even make stairs like this...

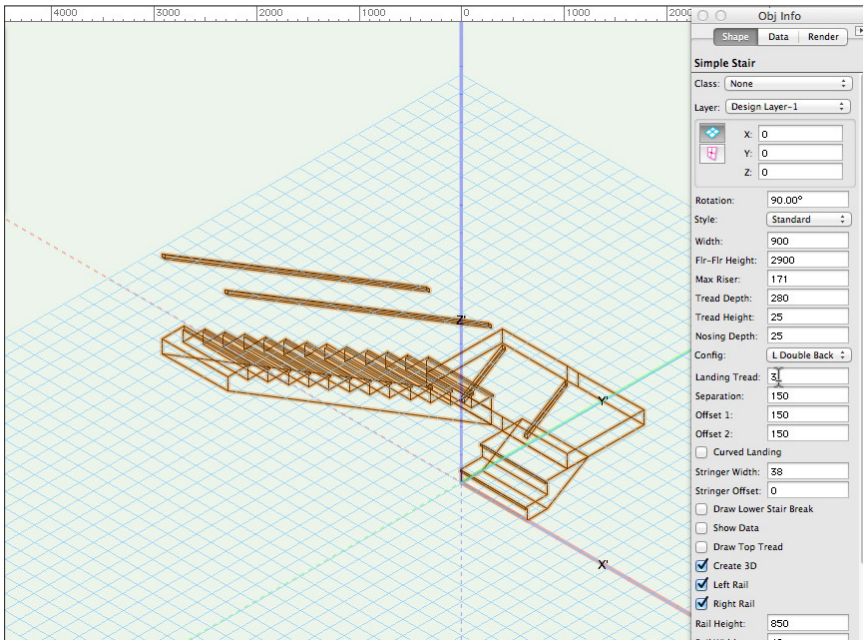

For complex stairs that do not follow 90° or 180° corners, you can use a combination of stairs and floors.

These are the settings for the first flight.

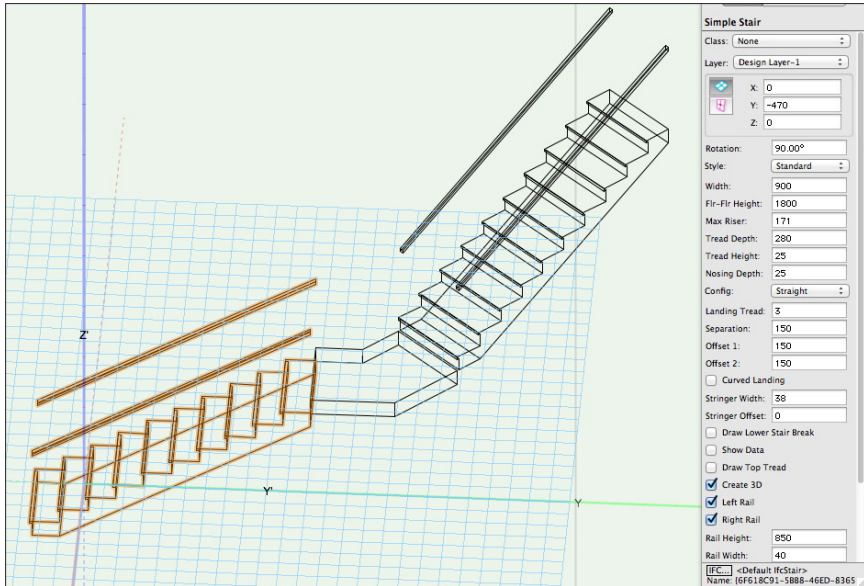

These are the settings for the landing.

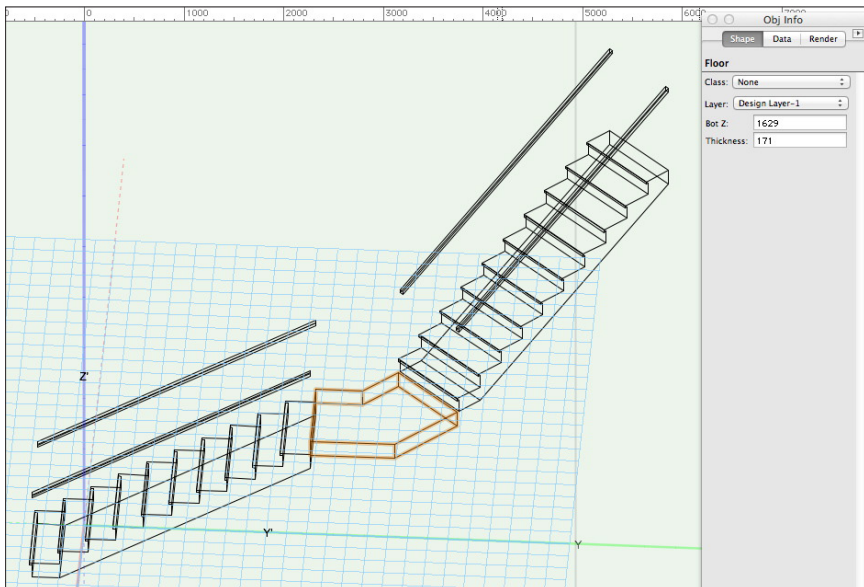

These are the settings for the top flight.

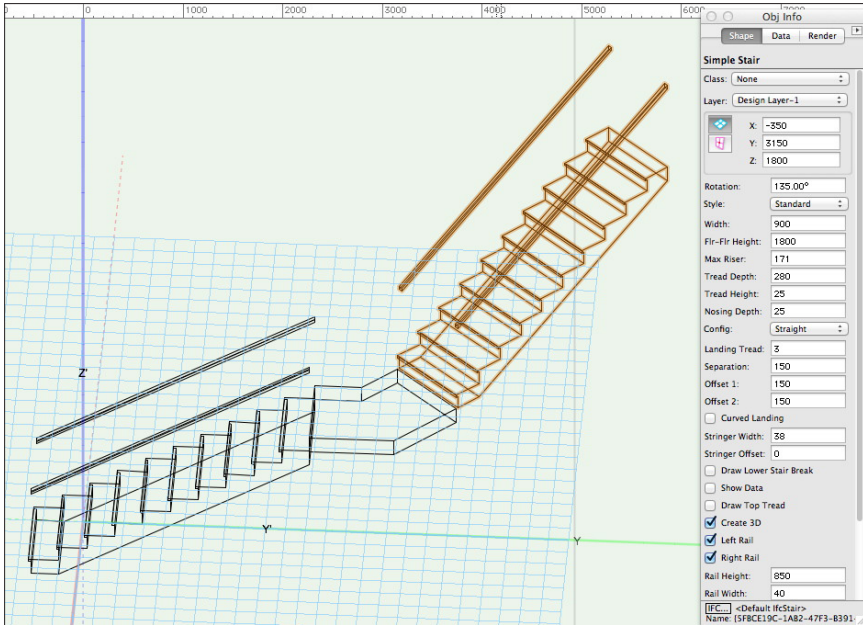

The Simple Stair tool can be used for many simple situations. But it is limited. There are lots of things but you cannot do. For example, you cannot create circular stairs, you cannot create stairs to get wider as they go down, and as you can see in the previous image, you have to trick Vectorworks to create stairs with different angles.

This simple stair can be edited with the Split tool.

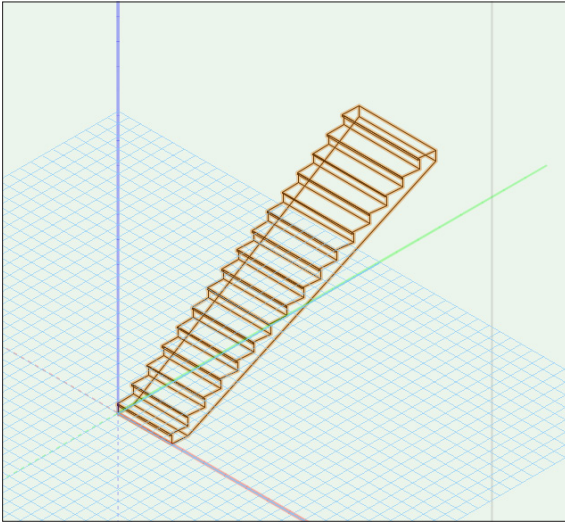

You can use the Push/Pull tool on it.

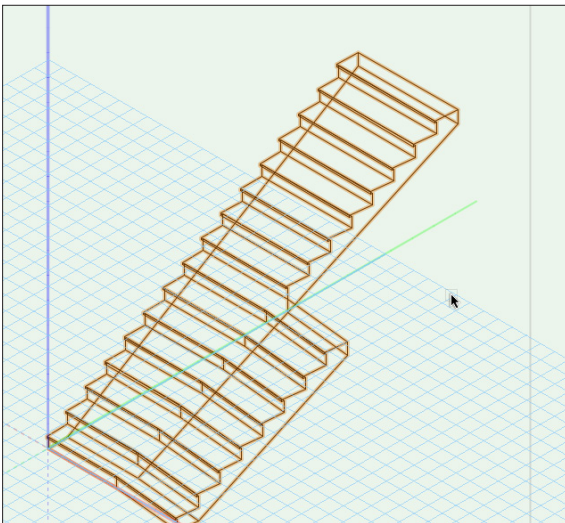

You can mirror two stairs.

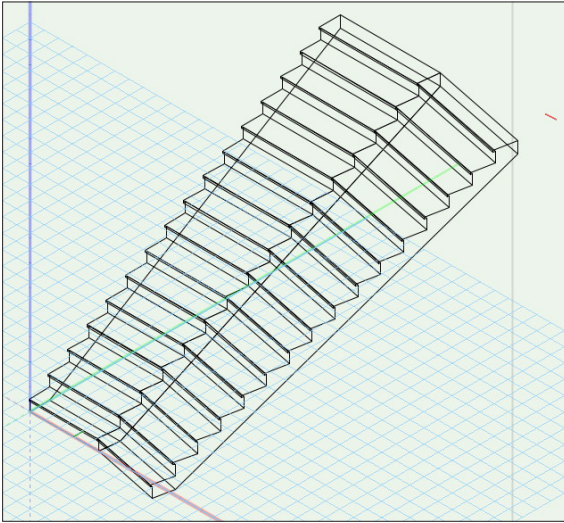

You can use the extract tool to extract the underside of the the stairs, and create a site modifier from it.

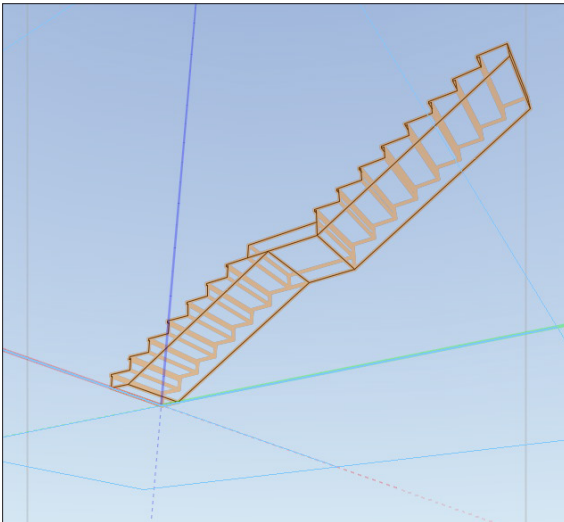

Circular Stair

[cadmovie870](#)

There is a very simple circular stair which uses the same concept as the simple stair above. Unfortunately you will have to add this stair to your workspace.

You will have to go to your workspace editor to add this to your workspace.

- Go to the **Menu** bar.
- Choose **Tools > Workspaces > Workspace Editor...**
- Locate the **Circular Stair**.

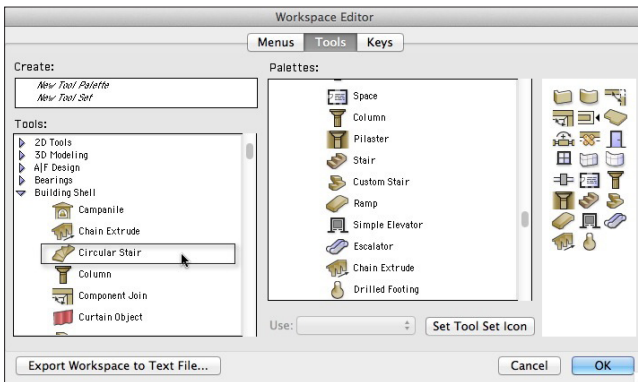

- Drag the circular stair tool to a suitable tool palette.

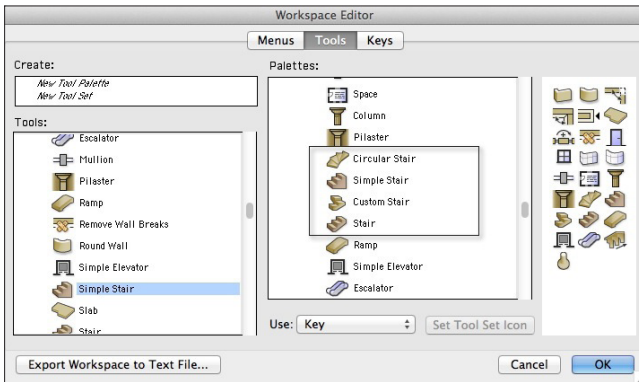

The Circular Stair uses the same concepts as the simple step above. The only difference is that the circular stair has controls for the outside radius and the total angle for the stair.

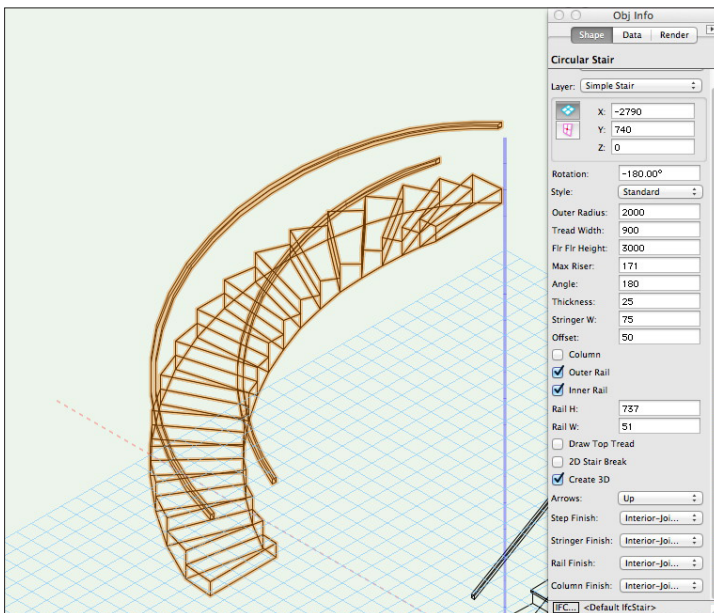

Custom Stair

Straight Stair

[cadmovie871](#)

The Custom Stair tool is designed to allow you to create a range of complex stairs. You can create stairs with several landings, circular stairs, stairs with landings at any angle, and you have more control over the landings. If you have Vectorworks 2009, the custom stair is called the Stair Tool. The Custom Stair is not available if you have Vectorworks Fundamentals.

The main concept behind the custom stair is that it is a kit of parts. You join together landings and flights to create the stair you want. This makes it very flexible, but it also makes it confusing for some people. The important part to remember is that each flight is an individual, and each landing is an individual.

- Go to the **Building Shell** toolset.

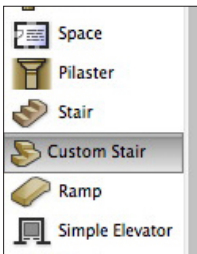

- Choose the **Custom Stair** tool (**Stair** tool if you are using Vectorworks 12 - 2009).
- Go to the **Tool bar**.
- The last mode is to set the preferences for the stair.

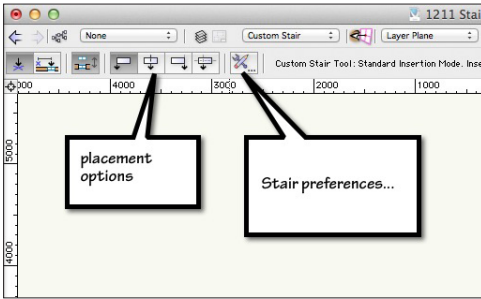

- Click on the **Preferences** button.
- This is where you choose your starter stair, which works like a template.
- Click on the symbols picture.

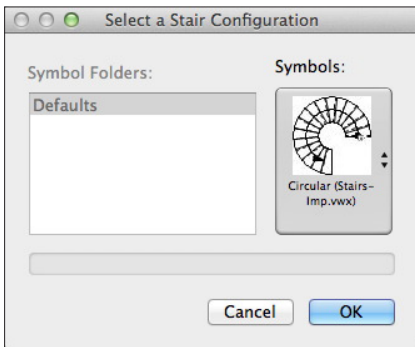

- You will see a list of all the available stair symbols. This list will reflect your default settings. I have saved some symbols into the library so I can easily create a new stair that suits me.
- Click on a **Straight** stair.

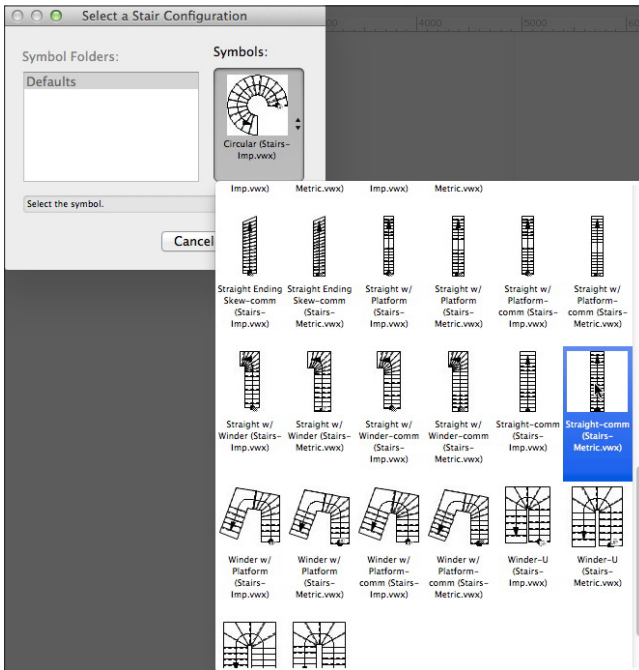

- Click on the **OK** button.
- This dialog box controls all the settings for the stair.
- Click on the **General** tab. You can set the overall height, width of the stair, riser and tread.

- You can specify the overall height.

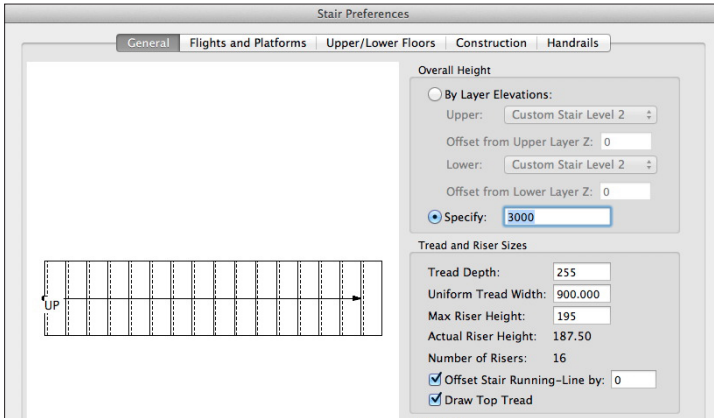

- You can use the layer settings to control the overall height of the stair.

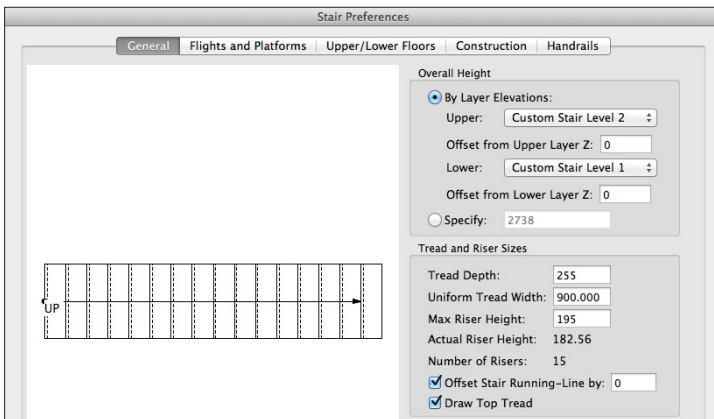

- This is what the tread depth and riser height relate to.

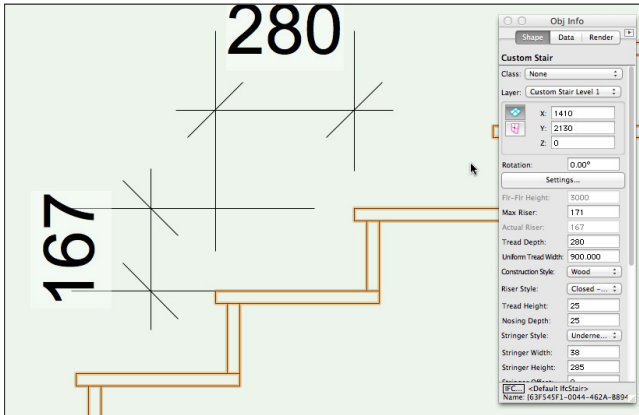

- Make sure you set the start and end arrows to suit your drawing style.
- Click on the **Flights and Platforms** tab. This is used to build the stair. Unlike the other stair tool, this stair is built out of parts (flights, platforms and winders).

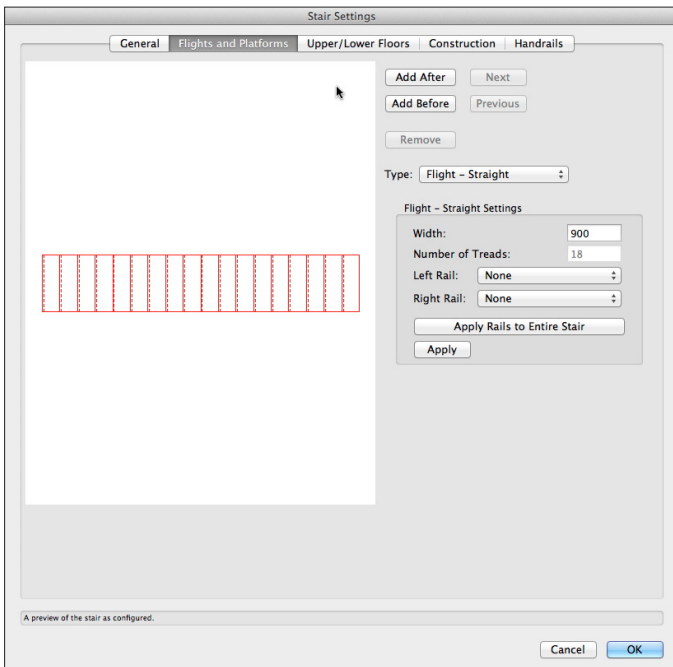

- Enter the settings for the width of the stair and the handrail.
- Click on the **Upper/Lower Floors** tab. This is only used if you use layers to set the stair height. Unlike the other stair, this one allows you to have the stair appear on two layers, and they both update when you edit the stair.

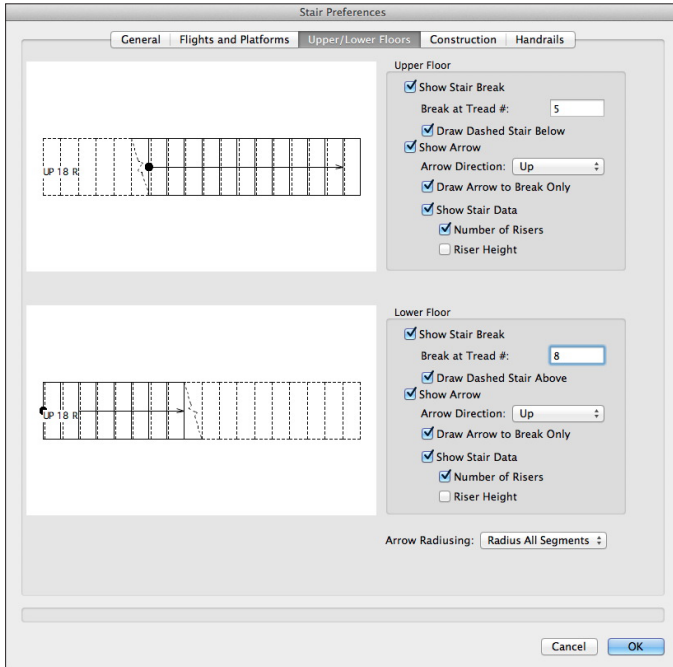

- Click on the **Construction** tab.
- Make your choices for the construction.
- You can assign parts of the stair to various classes, but the classes are fixed, you can't use any class names, you have to pick from the list.

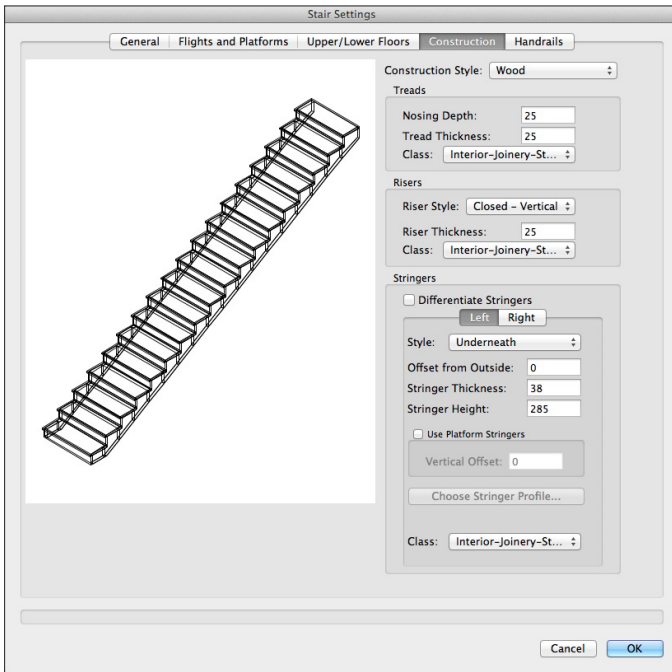

- Click on the **H**andrails tab.
- Make your choices for the handrails and guardrails. These are not as easy to create as the other stair.
- You can assign the handrails and guardrails to a class, but the class names are fixed, have to pick from the list.
- Click on the **OK** button. To get back to the drawing.

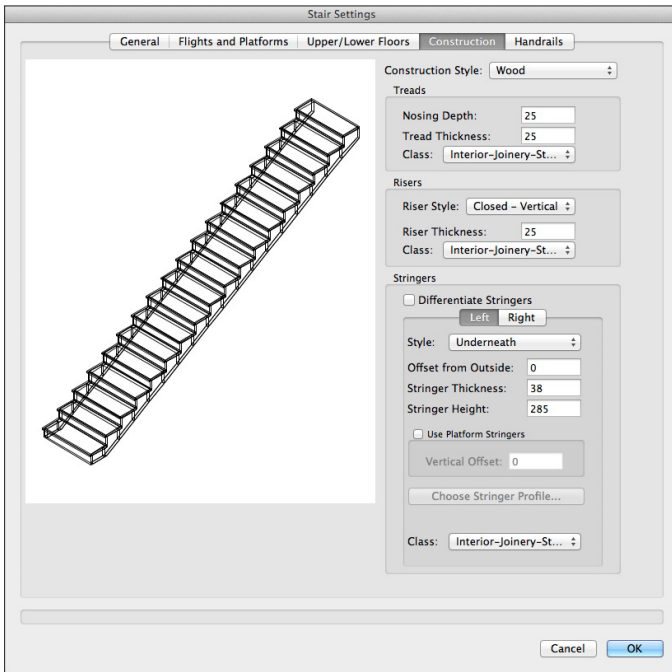

- Most of the stair settings can be editing on the **Object Info palette**. This is not like the other stair, and it does make it quick to edit.
- Here is a plan view of the stair. So far, this is a simple stair. It is easier to get all the construction settings for the simple stair, then look at making the stair more complex.

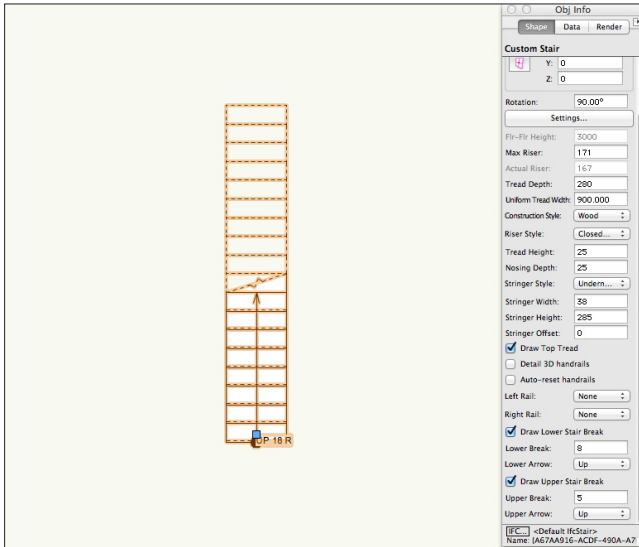

The Custom stair can be placed on two layers. When you move the stair on one layer, it updates on the other automatically. The stair will use the layer settings (Layer Z) to calculate the height of the stair for you.

- Double click on the stair
- Click on the **General** tab.
- Click on the option, **By Layer Elevation**.
- Choose your upper and lower floors.
- Click on the **Upper/Lower Floors** tab.

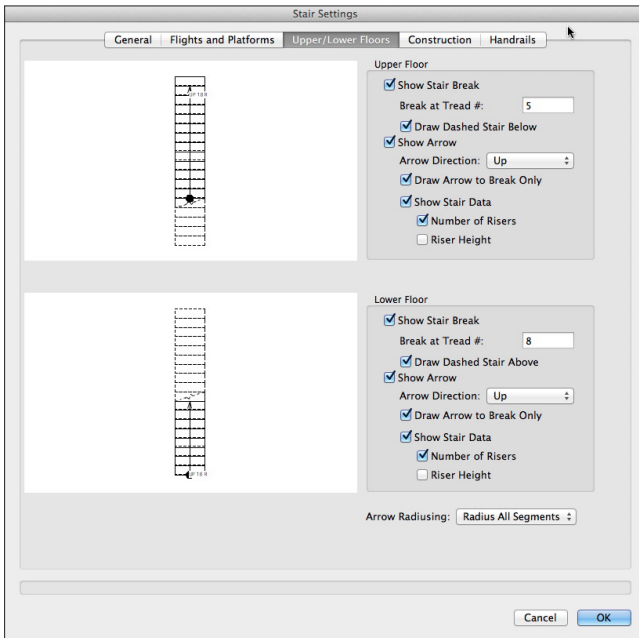

- Now you can set the viewing options for each floor.
- Click on the **OK** button.

This is the view on the lower floor.

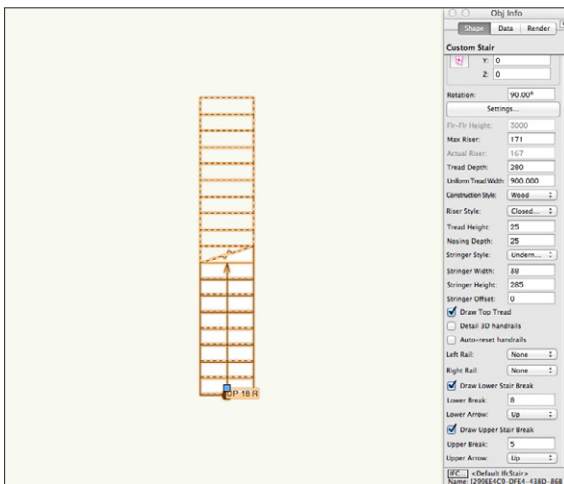

This is the view on the upper floor.

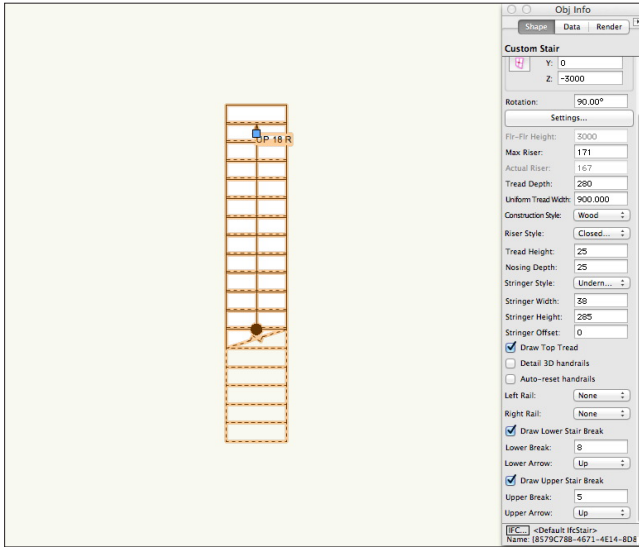

Other Stair Options

[cadmovie872](#)

The custom stair is a flexible stair, and you can make very complex stair with it. To use the stair effectively, you need to understand the basic concept behind the stair. The custom stair is a like a kit of parts. You assemble the stair from parts. The parts can be flights (straight or curved stairs), platforms (landings) and winders. So, you do not design a stair in one go, you design each part, and the parts add up to a stair.

- Double click on a stair to open the settings.
- Click on the **Flights and Platforms** tab. This is where you design the stair by adding and taking away stair parts. The parts can be Flights, Winders or Platforms.
- The first platform is selected, that is what the red color shows you.

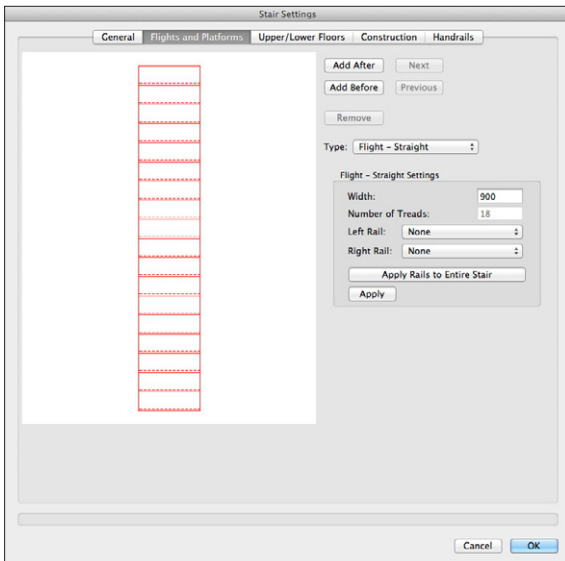

- Click on the **Add After** button. This is how you add parts to the stair.
- Choose the **L Platform** option. You could choose anything want, but I wanted to show you how to make a complex stair.

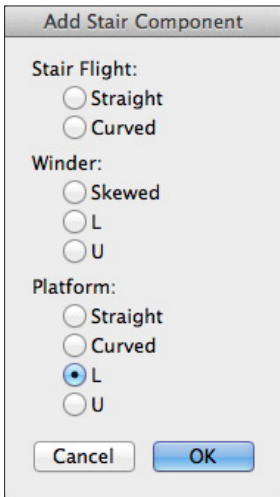

- Click on the **OK** button.
- The L Platform looks a little strange. When you edit the settings it will look more like a stair landing.

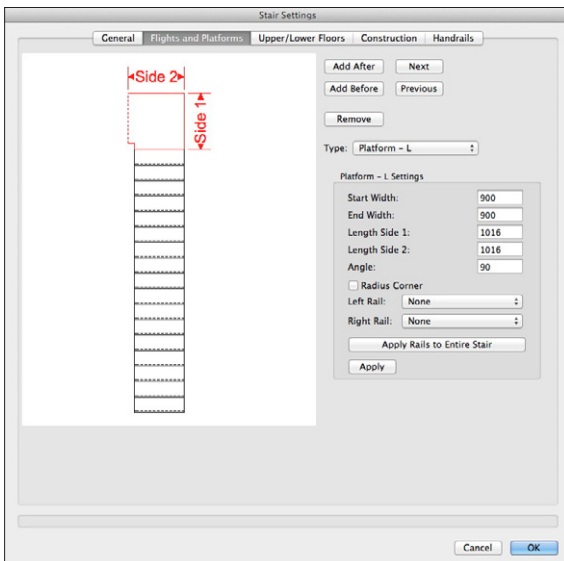

- Change the **Angle** to **90**.
- Click on the **Apply** button to see the updated stair. Vectorworks will not

act on the updated settings until you click on the **Apply** button.

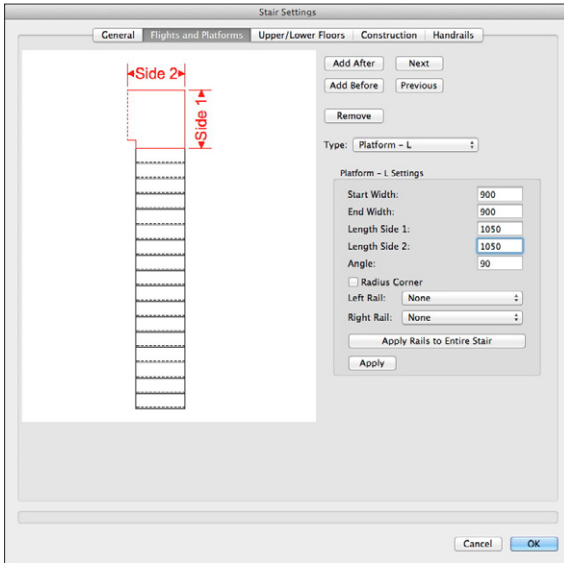

- Click on the **Add After** button.
- Choose the **Straight Stair Flight** option.
- Click on the **OK** button.

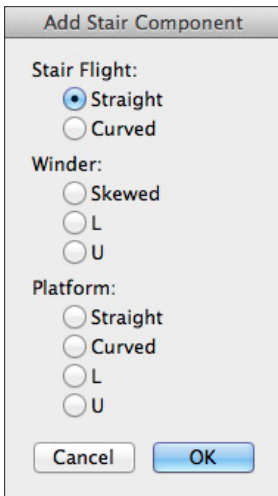

- The New flight is added.

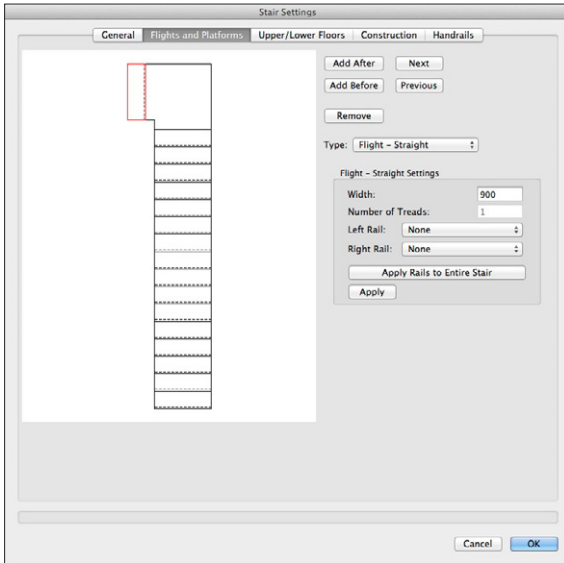

- Click on the **Previous** button until the bottom flight is red.
- Change the number of treads to **4**.
- Click on the **Apply** button.

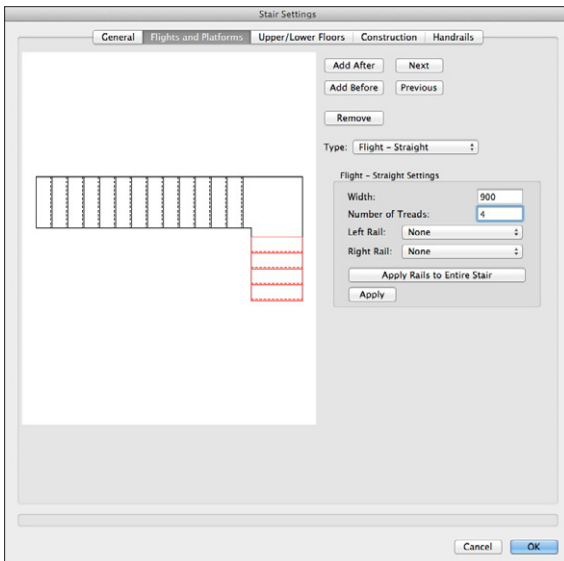

The stair requires a number of risers to reach the upper floor. When you take the treads off the bottom flight, the upper flight has to have extra treads added to it. Vectorworks does this for you.

- Click on the **Next** button until the top flight is highlighted.
- Click on the **Add After** button.

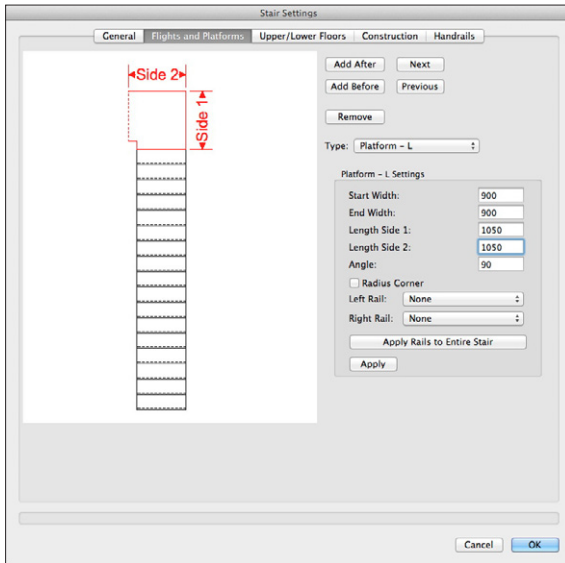

- Choose the **L Platform** option. You could choose anything want, but I wanted to show you how to make a complex stair.
- Click on the **OK** button.

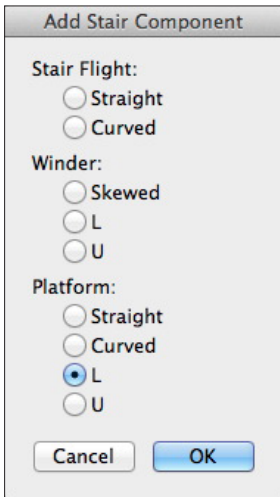

- Edit the settings it will look more like a stair landing.
- Change the **Angle** to **-90**.
- Click on the **Apply** button to see the updated stair.

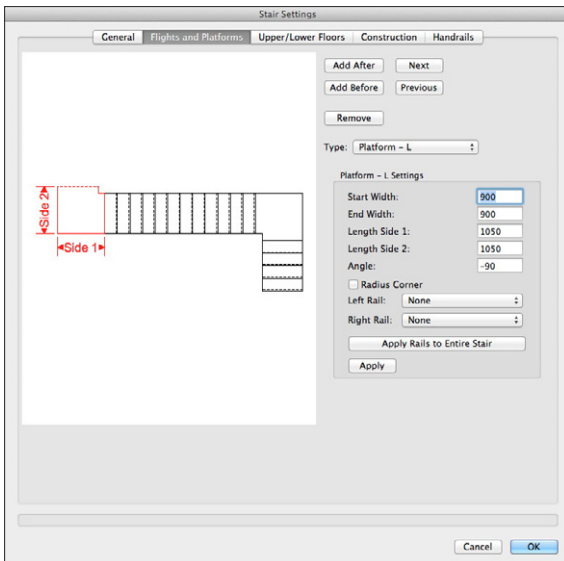

- Click on the **Add After** button.

- Choose the **Straight Stair Flight** option.
- Click on the **OK** button.

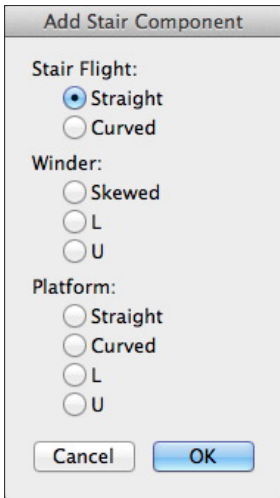

- Click on the **Previous** button until the middle flight is red.
- Change the number of treads to **6**.
- Click on the **Apply** button.

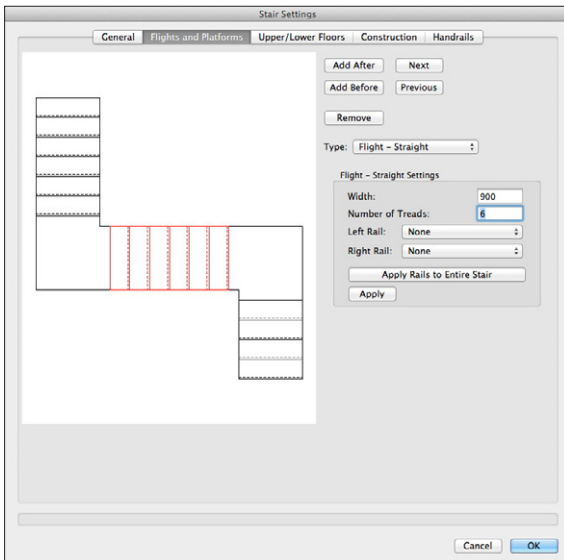

- When you have all the settings you want, click on the **OK** button.

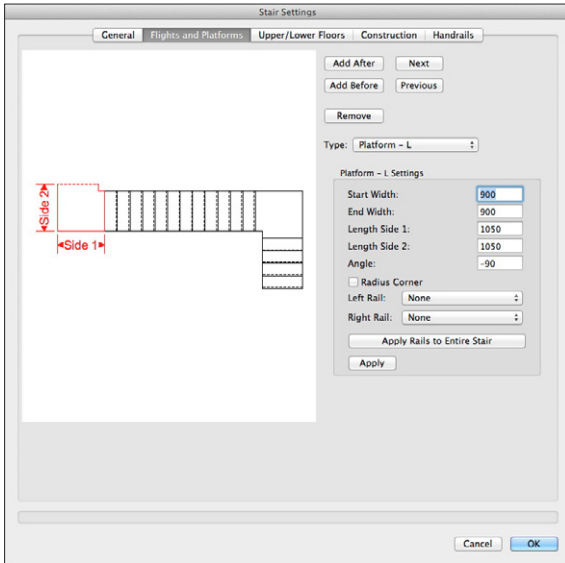

Stair on the lower floor.

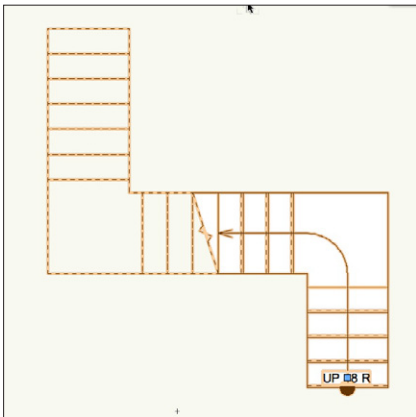

Stair on the upper floor.

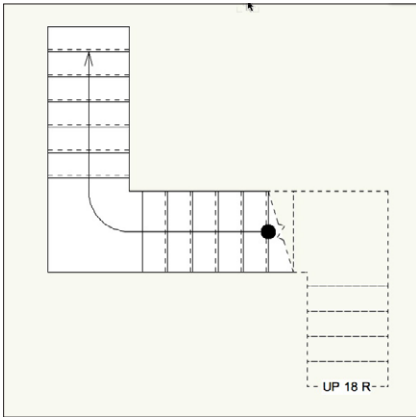

- Double click on a stair to open the settings.
- Click on the **Flights and Platforms** tab.
- Click on the **Next** button until you highlight the first platform (landing).
- Click on the **Type** pop-up menu.
- Choose **Platform U**.

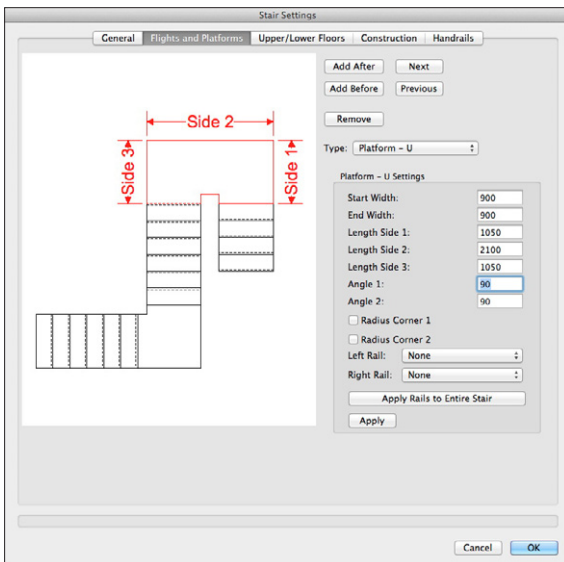

- Change the settings for the length and angle.

- Click on the **Apply** button. Now the landing looks better.
- Click on the **Next** button until you highlight the second platform (landing).

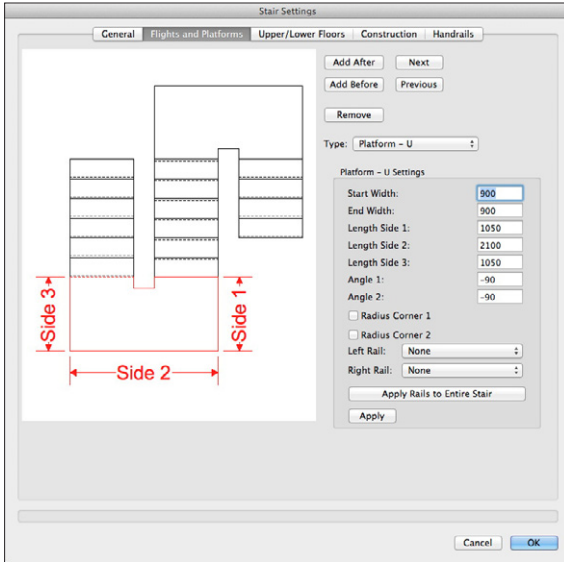

- Click on the **Type** pop-up menu.
- Choose **Platform U**.
- Change the settings for the length and angle.
- Click on the **Apply** button.
- Click on the **OK** button.

Here is the stair on the lower floor.

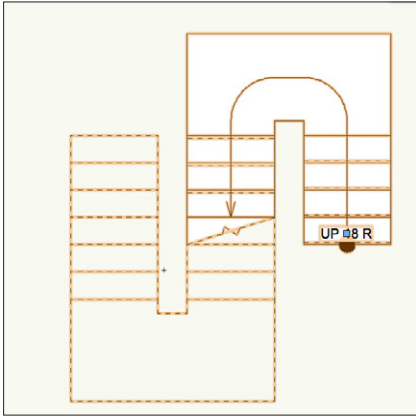

Here is the stair on the upper floor.

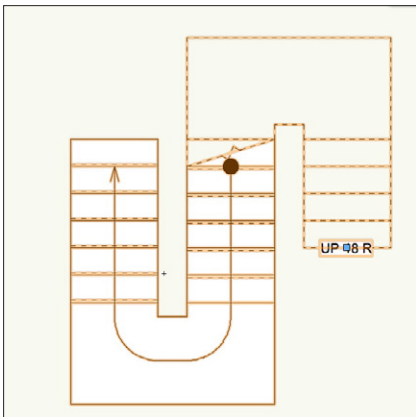

After you have placed the stair, you may want to relocate the stair data. In the image above, the stair data is not connected to the arrow. This their data is controlled by the blue handle in the middle.

- Go to the Basic tool set.
- Click on the Selection tool.
- Move your cursor to the blue handle on the stair data. Your cursor will change shape to an interactive scaling cursor (reshape cursor).
- Click once.

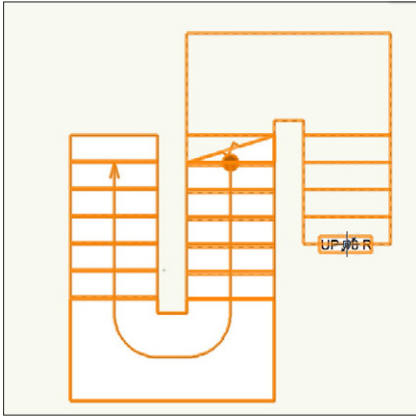

- Move to the desired location for the stair data.
- Click once.

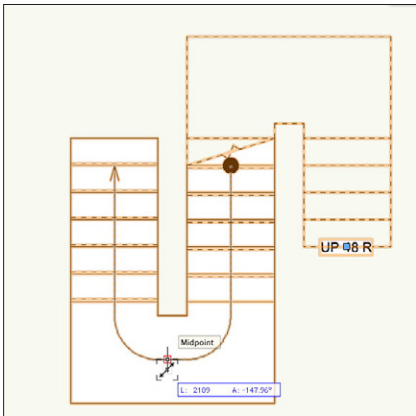

This will relocate the data.

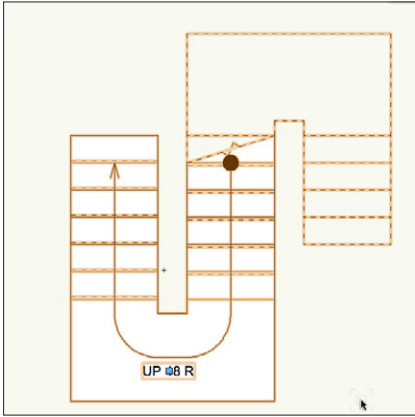

This stair was made with the Custom Stair tool.

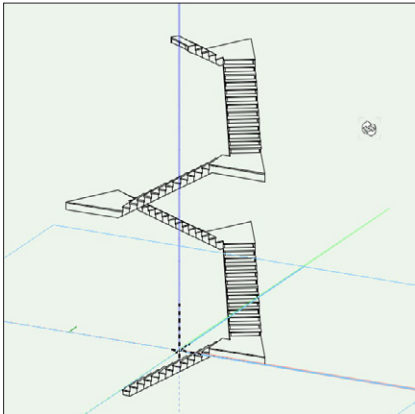

I think that the custom stair tool is extremely flexible. You do have to remember that you are creating your stair from a kit of parts and therefore you have to treat each part of the stair as an individual. The combination of these individuals creates the stair.

For landscape use, the stair is so flexible that you can create winding and twisting paths. If you extract the surface from the underside of each stair component, you can turn these into site modifies.

Stair Tool - Straight Stair

[cadmovie873](#)

The stair tool has a completely different way of working from the custom stair tool. This can cause some confusion if people try to use their working methods from the custom stair on this tool. This stair tool is not as flexible as the custom stair tool, but it has a lot more control over all of the individual components. That makes the stair more useful for developed design and construction documentation.

The stair tool is only available for Architect and Designer. If you have Landmark or Spotlight, you will not have access to this tool.

- Go to the **Building Shell** toolset.
- Choose the **Stair** tool.

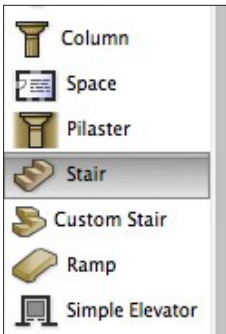

- Go to the **Tool** bar. This tool has several icons.
- The first mode is to insert a stair.
- The second mode apply the copied settings to a stair.
- The third mode is to copy settings from a stair, so you can use the second mode to apply them.
- The fourth mode is to update all the stairs in the drawing.

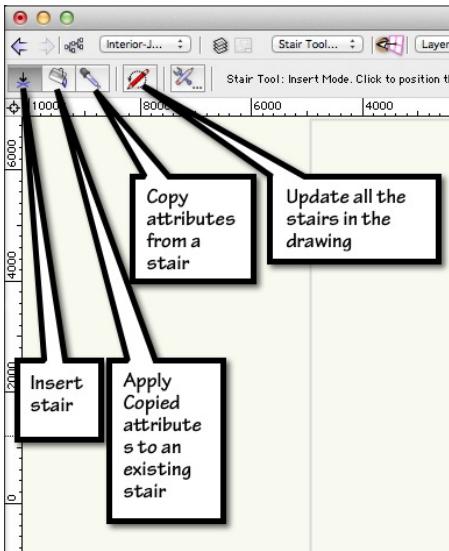

- The last mode is to set the preferences for the stair.
- Click on the **P**references button.

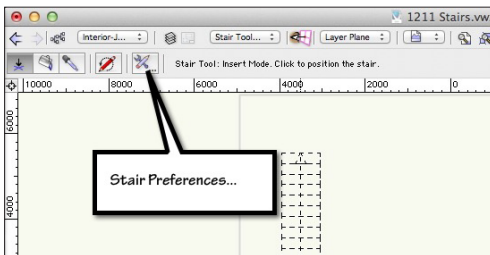

- This is the control centre for the stair. There are several things to look at here, but we will look at them one at a time.
- The **G**eneral tab is the starting point. This is where you set up the stair configuration.

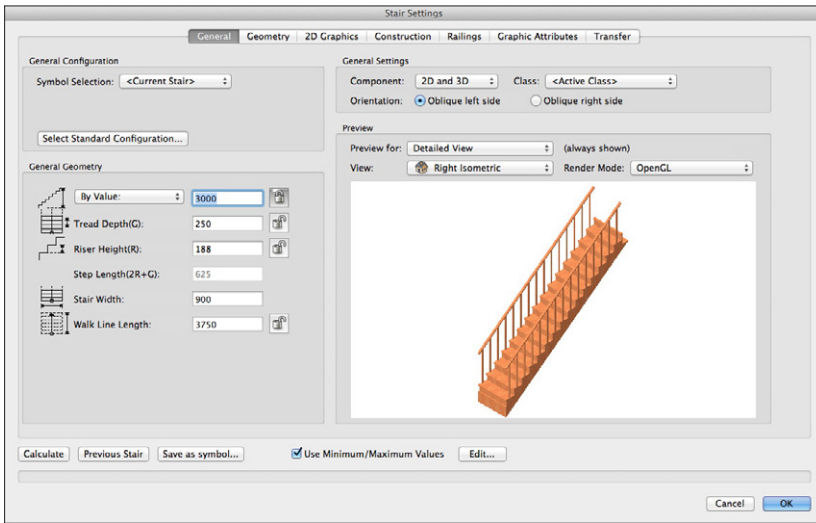

- Click on the **Select Standard configuration...** button.
- Choose the stair configuration you want. In this case choose a straight stair.
- Click on the **OK** button.

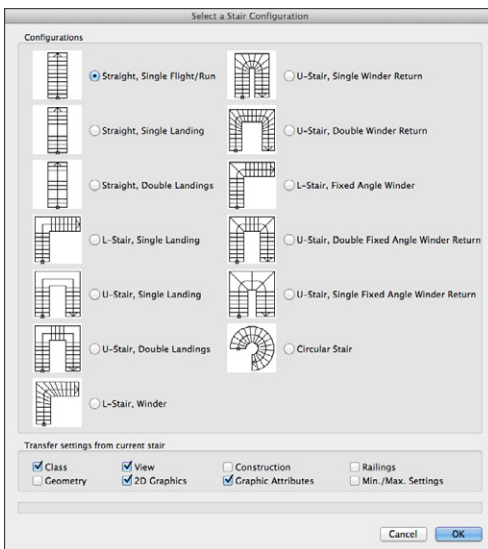

- Fill in the stair width, rise riser and so on.

- You can enter the stair height By Value or By Elevation (using the story heights).
- Click on the pop-up.
- Choose **By Elevation**.

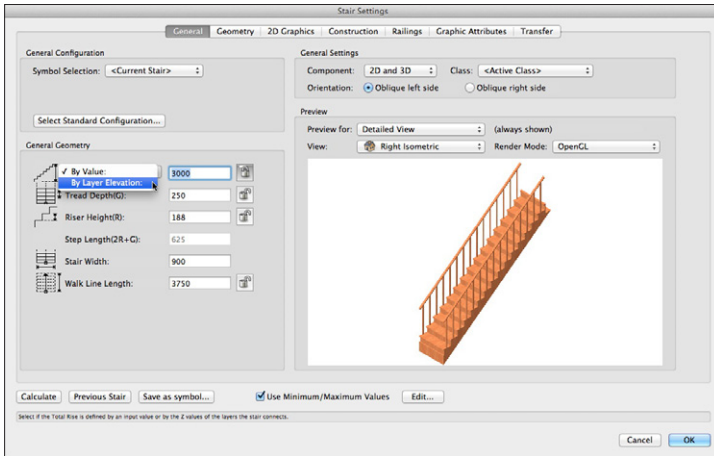

- Choose the top and bottom bounding.

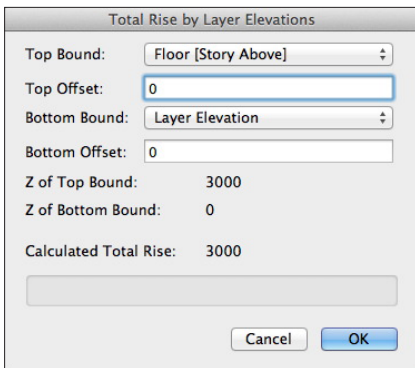

- Click on the **OK** button.
- When you enter the riser you might get a message.

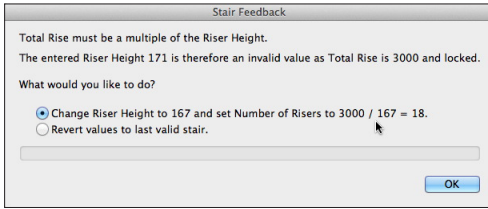

- Click on the **OK** button.
- There is an option for creating your own Min/Max. Settings, so you can set up options for residential and commercial stairs, but you do not have to use these, you can turn off the option to **Use Minimum/Maximum Values**.

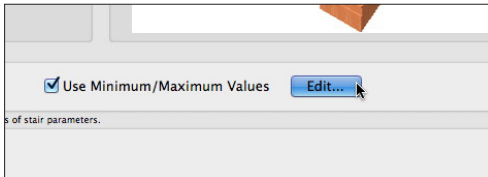

Before you make any changes to these settings, you must ensure that the current stair settings comply with the settings you enter. If not, you will get an error message.

- Click on the **Edit...** button.
- This dialog box lets you set minimum and maximum settings for your stair. If you are working in a commercial building the maximum riser might be less than in a residential stair.
- Edit the settings to suit.

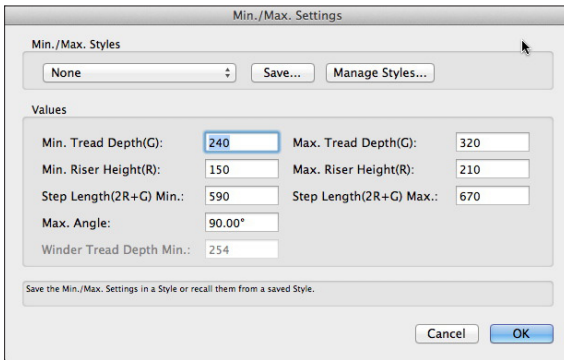

- Click on the **Save...** button.
- You can create a new Style, or over -write an existing style.

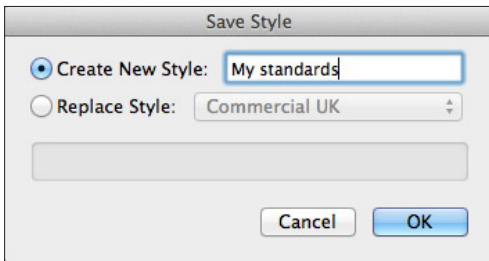

- Click on the **OK** button.
- Use this dialog box to recall settings you have saved to the type if stair you are making.

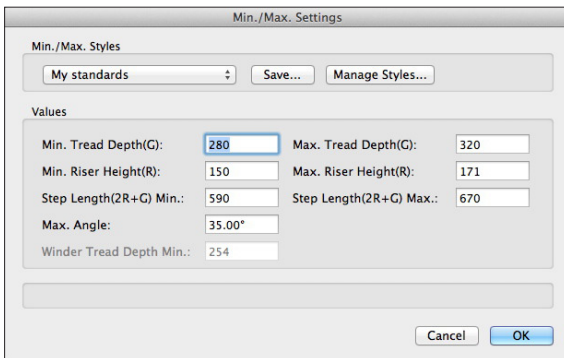

- Click on the **OK** button.
- Now, if you try to type in setting outside you the Min/Max. settings, you will get an error message.
- This is the error message you get. It means that your settings are outside the limits of your Min/max...

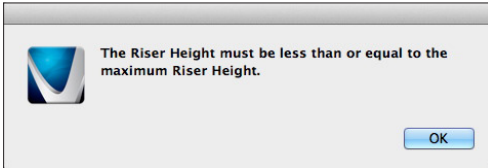

- Click on the **OK** button.
- Fix the problem setting, or the stair will fix it for you.
- This is what the tread depth and riser height relate to.

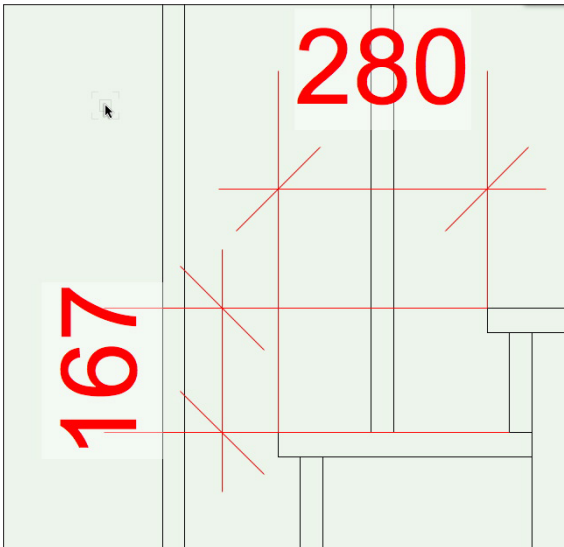

- Go to the **General Settings**.
- Select the 2D and 3D Settings.
- Choose a class for the stair. This is a class for the overall stair object.

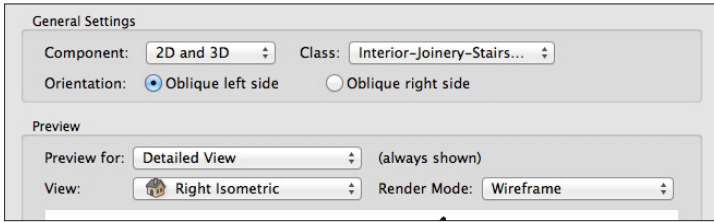

- Click on the **Geometry** tab.

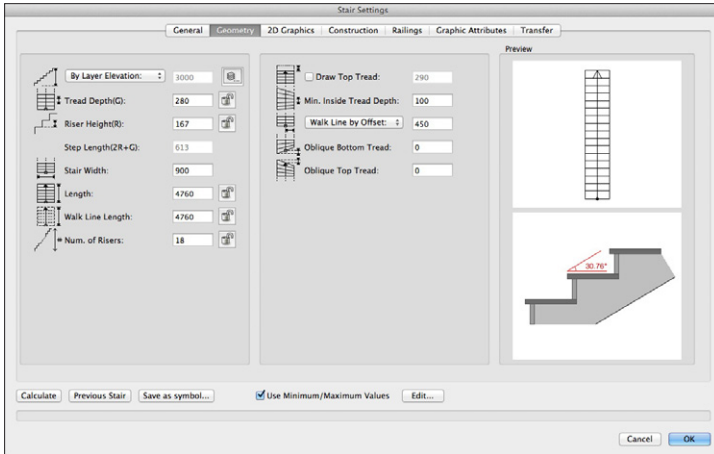

- Look at the basic geometry. You will notice a repeating of the basic geometry from the first part of the dialog box.

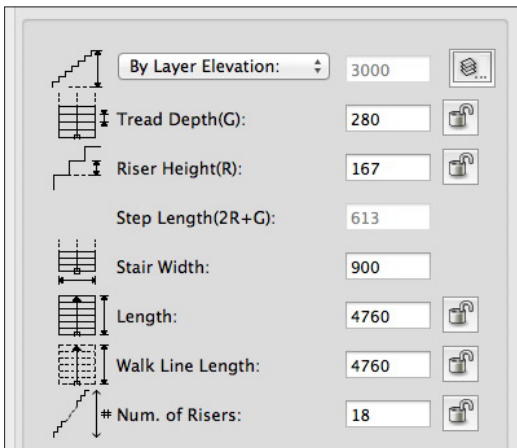

- The lock button is used to fix a part of the geometry, so that when you change some settings, the locked setting does not change.
- Look at the detailed geometry. This allows you to set detailed changes to the stair, creating oblique top or bottom treads to suit the building geometry.

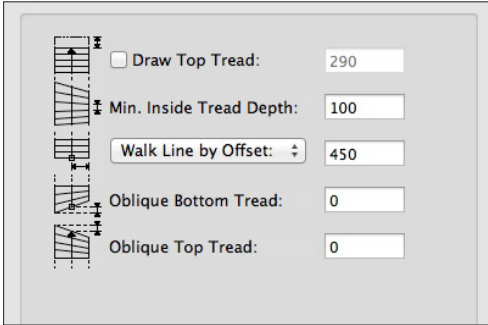

- Look at the **Preview**. This allows you to see what the stair geometry looks like.

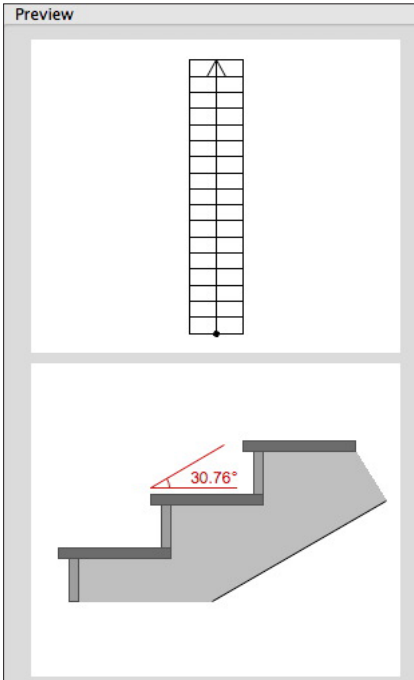

- Click on the 2D Graphics tab. This is where you control the look of the stair in 2D. You can set the break, the arrows on the stair, and so on.

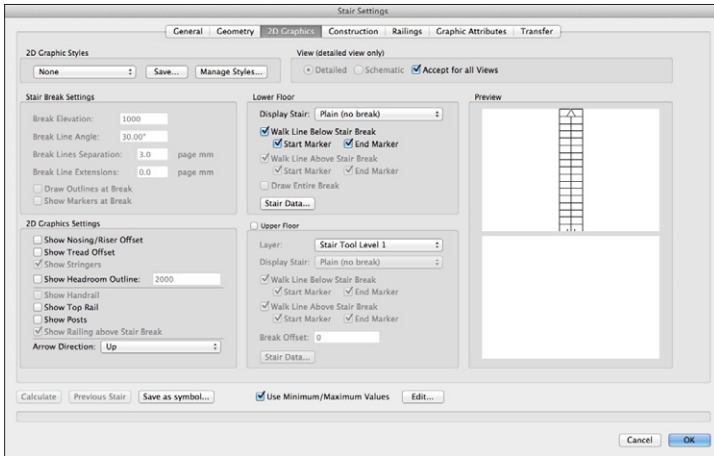

- Set the graphics to suit your way of drawing. When you make changes to the options, you can see the results in the preview window.

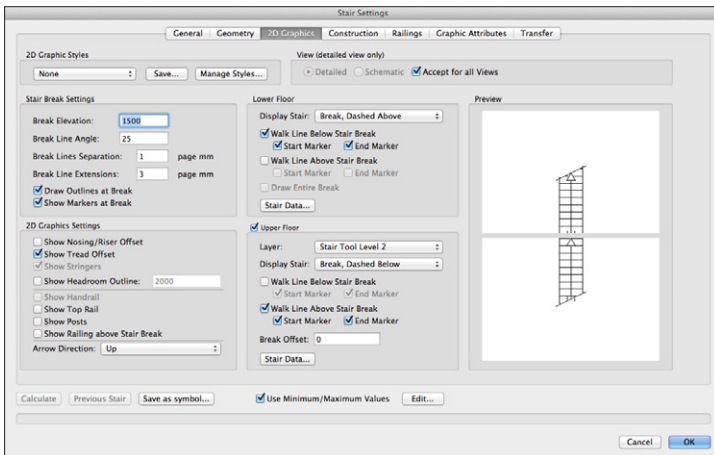

- When you are happy about your choices, click on the **Save...** button to save your style.
- Name the style to make it easy to find. This technique of saving styles, makes it easy to recall other styles.

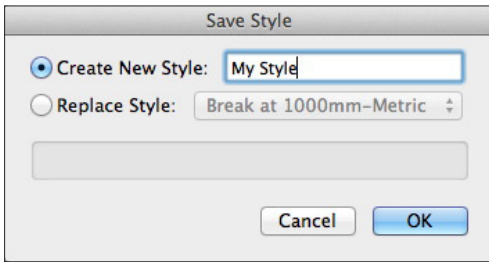

- These styles are like favorites that you can recall when you want them.
- If you take some time to set them up, you will find this stair very quick and powerful.
- Notice how quick it is to change the setting, when you choose a pre-made style.

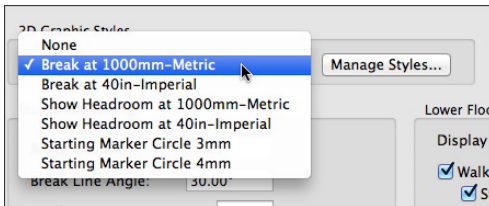

- Click on the **Construction** tab. This is where you choose the settings for the construction of the stair.
- Try out the settings on the stair until you get the stair setting that you want.

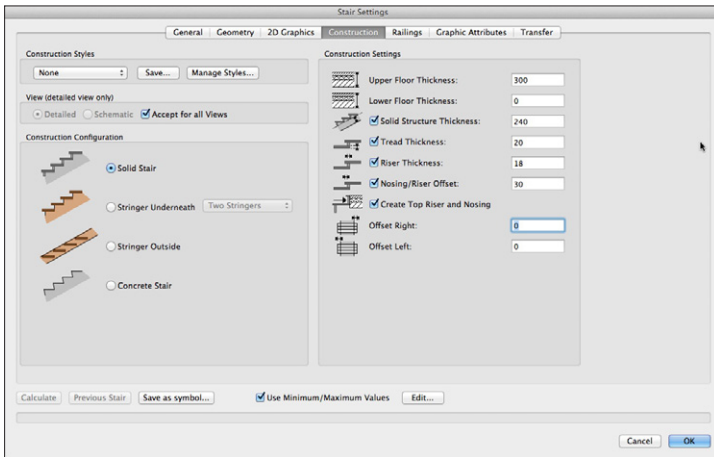

- Click on the **Save...** button to save the construction settings.
- Name the settings to make them easy to remember.
- Click on the **OK** button.
- Click on the **Railings** tab. This is where you choose the settings for the construction of the handrail and panels.
- Try out the settings on the stair until you get the handrail setting that you want.
- Click on the **Save...** button to save the settings.
- Name the settings to make them easy to remember.
- Click on the **OK** button.

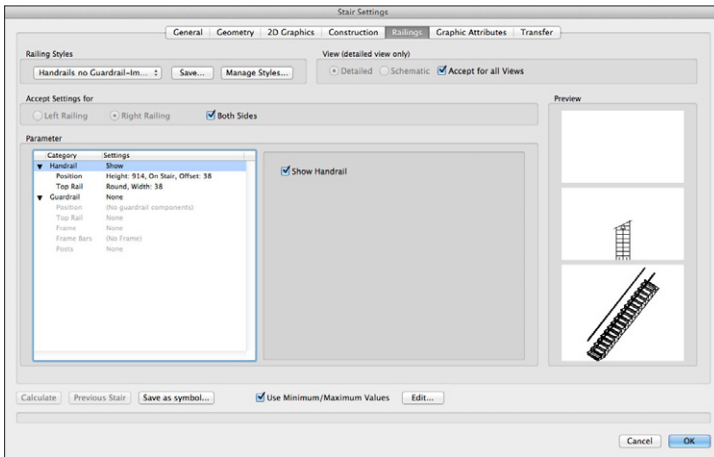

- Click on the **Graphic Attributes** tab. This is where you choose the graphic settings.
- Try out the settings until you get graphic style that you want. To edit a setting, double click on it.
- Click on the **Save...** button to save the settings.
- Name the settings to make them easy to remember.
- Click on the **OK** button.

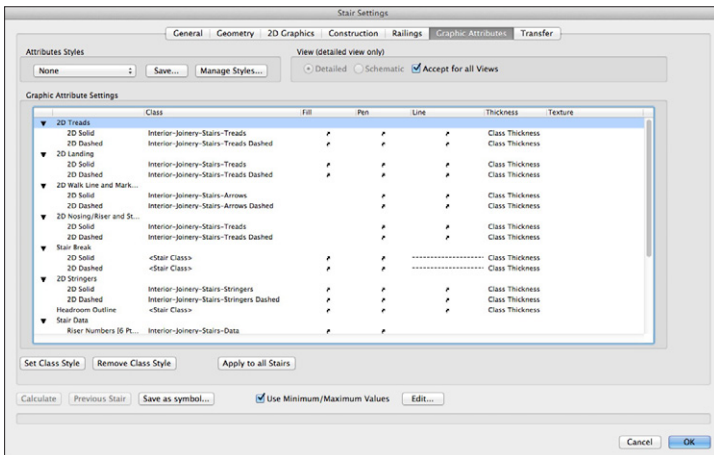

- Click on the **OK** button. The stair is created.

- You can set up a series of classes for the stair, and use these to control the textures on the stair parts.
- The Graphic Properties tab on the stair settings controls the textures.
- When you edit the Attributes for a component, you can set the class of the component, and you can set the class style for the fill, line and texture.
- This will allow you to use the classes to edit the textures and graphics on all the stairs, without going back into the stair settings.

If you have used the stair tool in Vectorworks 2009 or earlier, this is different way of creating a stair. The saving of favorites may be strange, but when you understand it, this becomes very powerful.

- Go to the **General** tab.
- Click on the **Save As Symbol...** button.

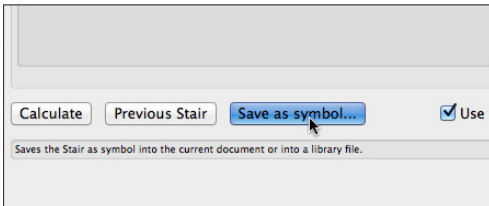

- Name the stair, and **Save as template in library** file.
- Click on the **OK** button.

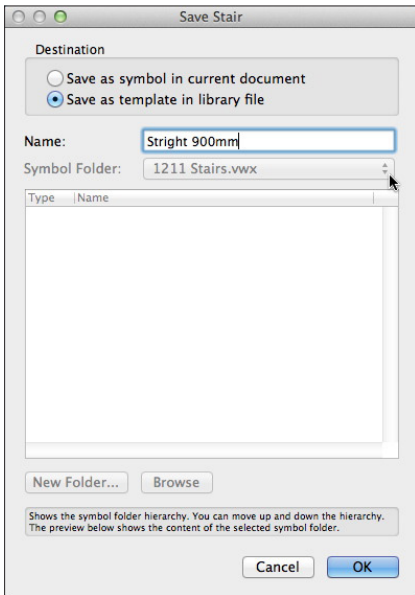

- When you are creating a stair, you can choose a stair symbol from the library.

Stair Tool - Stair with Landing

[cadmovie874](#)

- Go to the **Tool** bar.
- Click on the **Preferences...** button.
- Click on the **Select Standard Configuration...** button
- Choose **L-Stair, Single Landing**.
- Click on the **OK** button.

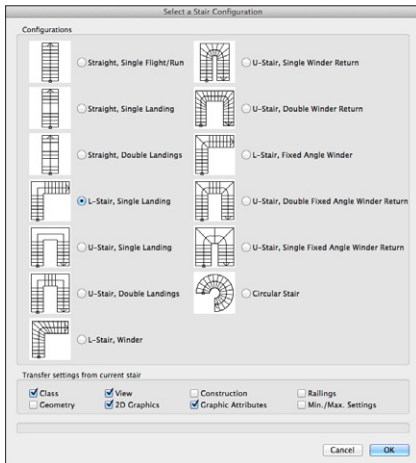

- You do not need to fill in the settings here, click on the **Geometry** tab.
- Check the Total Rise, Tread Depth, and Riser Height.

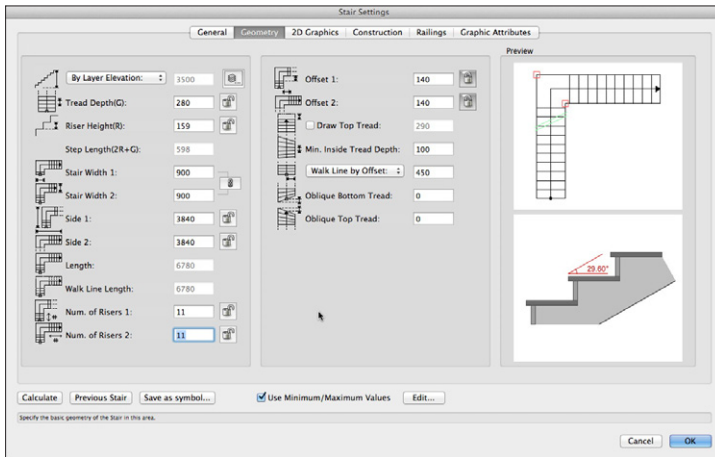

- Click in the input field for Offset 1. I used to worry about the side 1 and side 2 lengths, but you do not need to worry about it.
- **Offset 1** is the distance from the edge of the nosing to the change in direction. I usually use 1/2 of the tread. Type in your distance.
- Hit the **Tab** key once.
- **Offset 2** is the distance from the edge of the stair to the start of the nosing. I usually use 1/2 of the tread. Type in your distance.
- Hit the **Tab** key once.
- Click on the **2D Graphics** tab. This is where the favorites become so useful.
- Click on the **2D Graphic Styles** pop-up menu to choose your saved style.

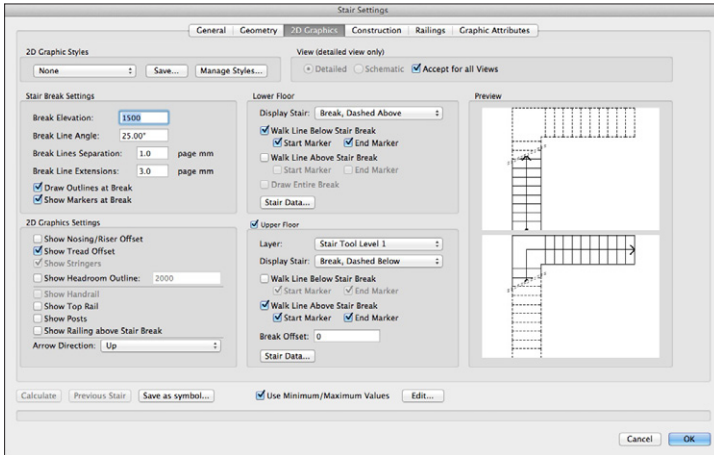

- Click on the **Construction** tab.
- Click on the **Construction Styles** pop-up menu to choose your saved style.

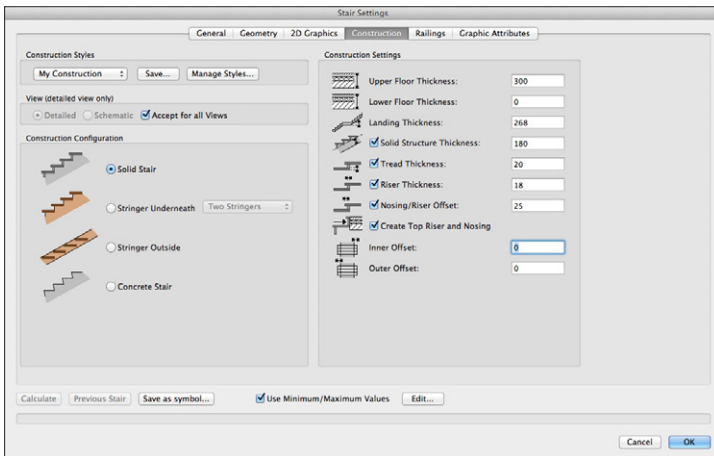

- Click on the **Railings** tab.
- Click on the **Railings Styles** pop-up menu to choose your saved style.

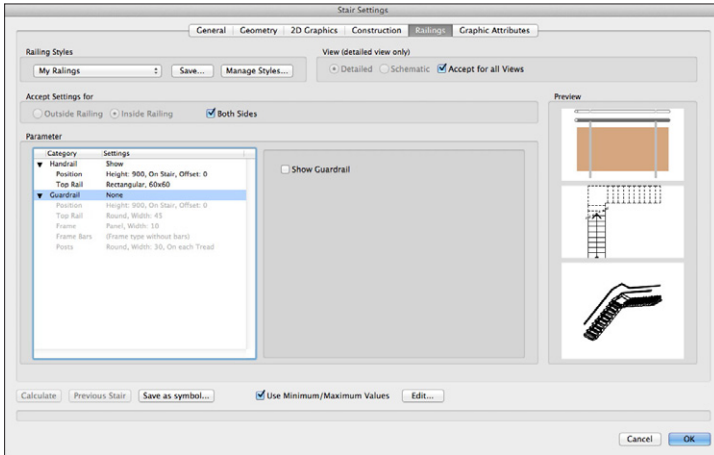

- Click on the **Graphic Attributes** tab.
- Click on the **Attributes Styles** pop-up menu to choose your saved style.

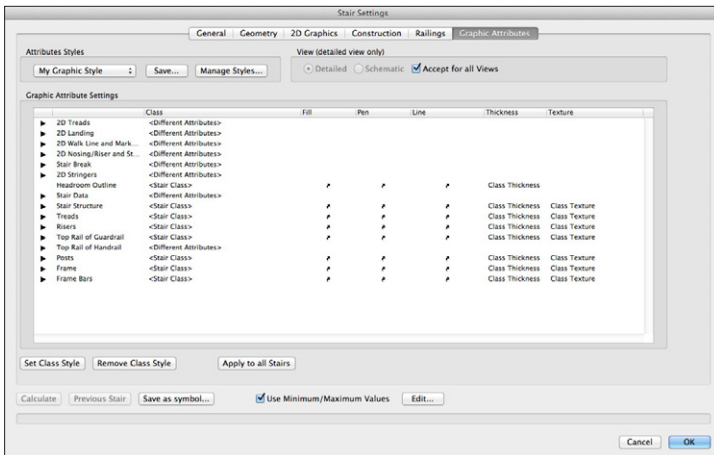

- If this was a typical stair, you should save it as a symbol to your library.
- Click on the **OK** button to finish the stair.
- In plan view the stair should have the settings you want.

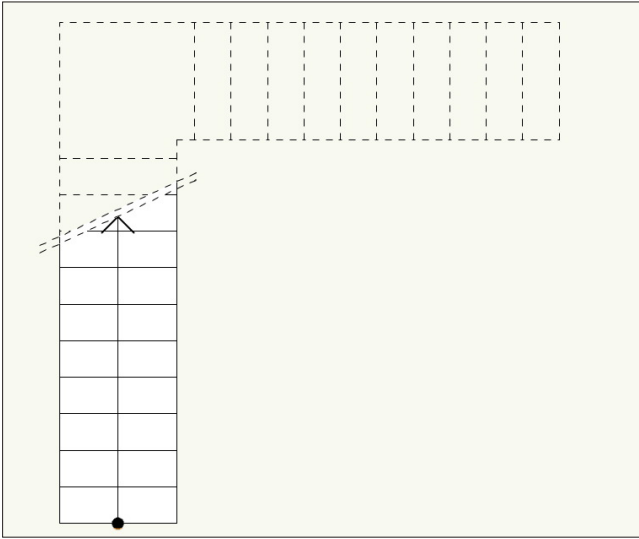

- In 3D the stair should have the setting you want.

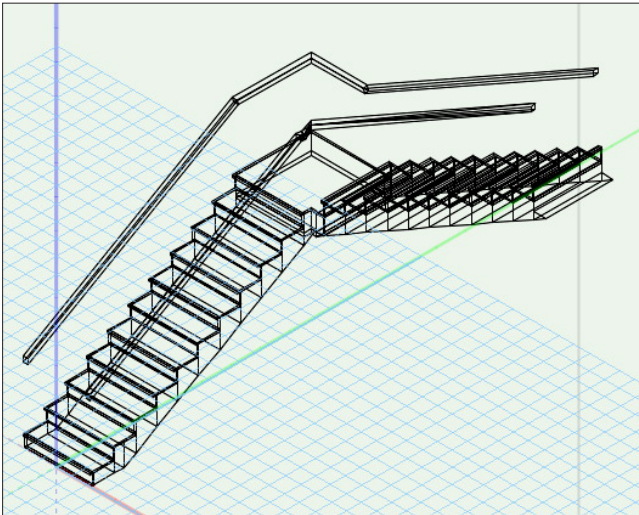

Stair Tool - U-Stair (Dog-leg Stair)

[cadmovie875](#)

- Go to the Tool bar.
- Click on the Preferences... button.
- Click on the **Select Standard Configuration...** button
- Choose **U-Stair, Single Landing**.
- Click on the **OK** button.

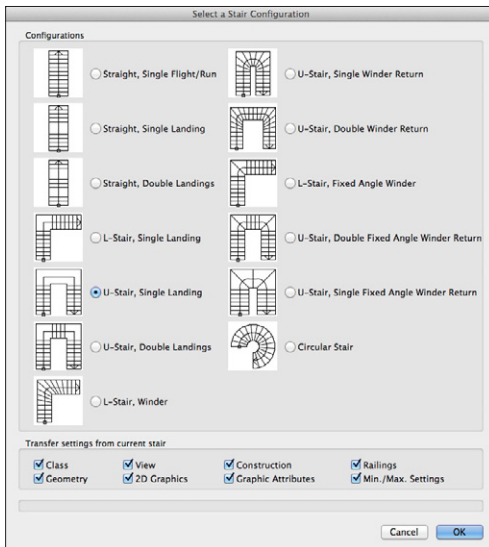

- You do not need to fill in the setting here, click on the **Geometry** tab.
- Check the Total Rise, Tread Depth, and Riser Height.
- Click in the input field for Offset 1. I usually use 1/2 of the tread. Type in your distance.
- Hit the Tab key once.
- Offset 2 is usually 1/2 of the tread. Type in your distance.

- Hit the Tab key once.
- Side 2 is the width of 2 flights plus the gap between.

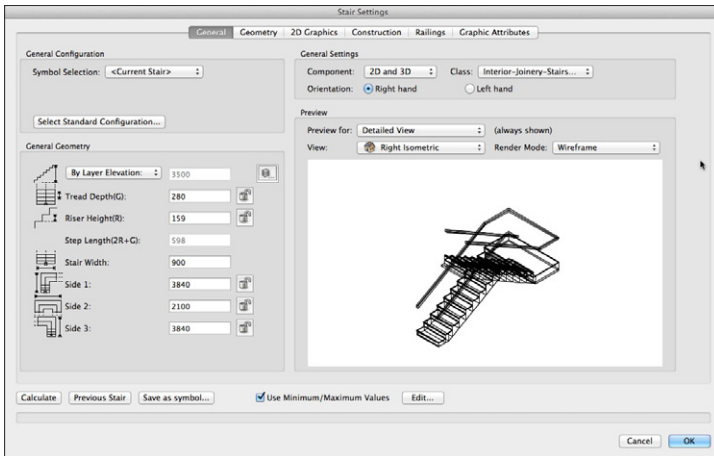

- Click on the **Geometry** tab. Choose your saved style from the **2D Graphic Styles** pop-up menu.

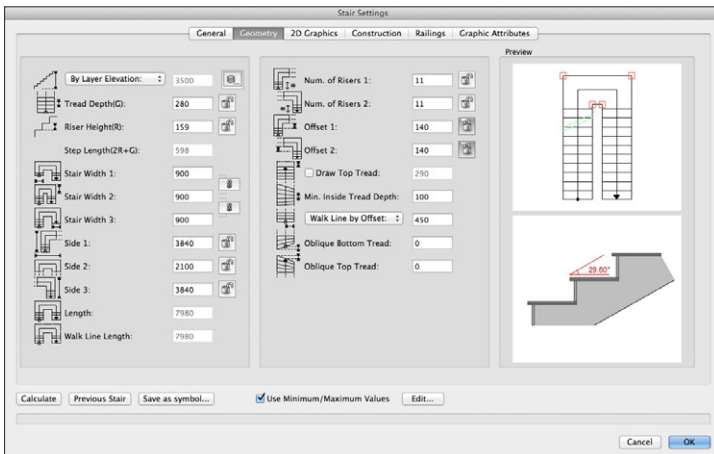

- Click on the **Construction** tab. Choose your saved style from the **Construction Styles** pop-up menu.

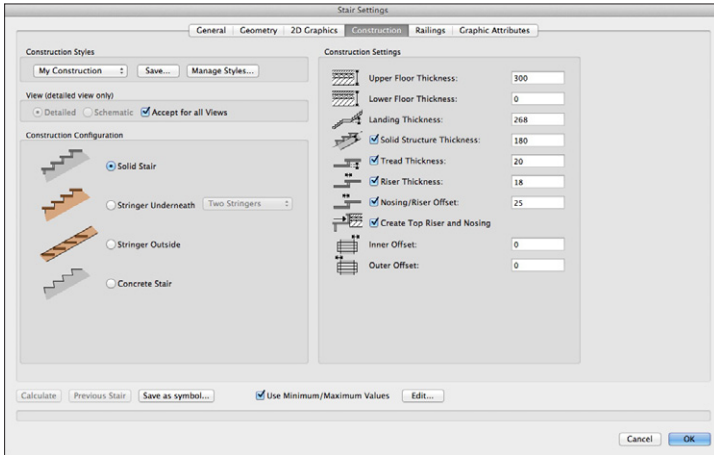

- Click on the **Railings** tab. Choose your saved style from the **Railings Styles** pop-up menu.

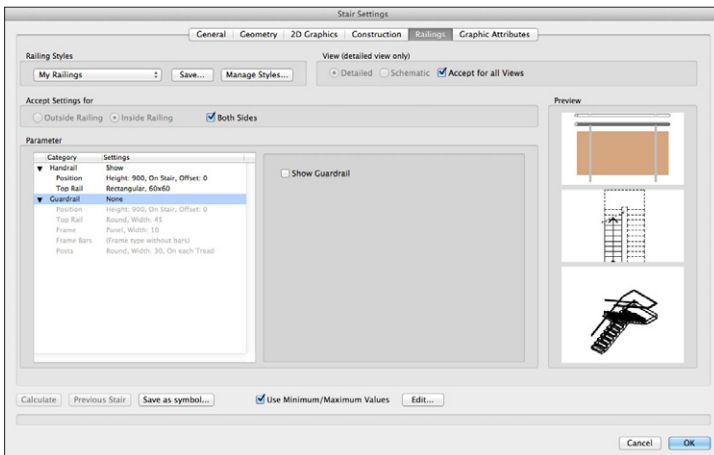

- Click on the **Graphic Attributes** tab. Choose your saved style from the **Attributes Styles** pop-up menu.

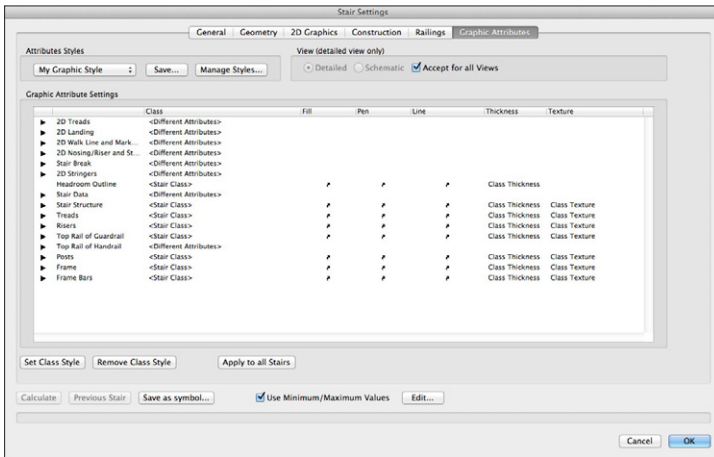

- If This was a typical stair, you should save it as a symbol to your library.
- Click on the **OK** button to finish the stair.
- In plan view the stair should have the settings you want.

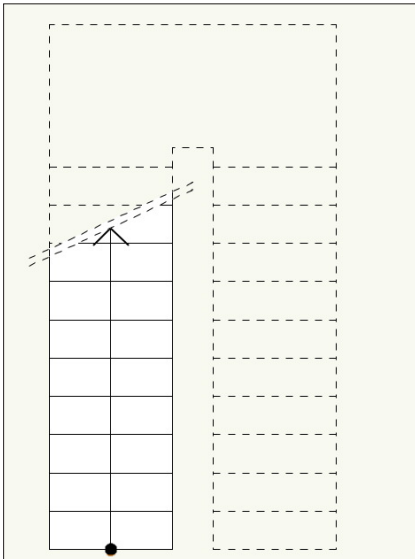

- In 3D the stair should have the setting you want.

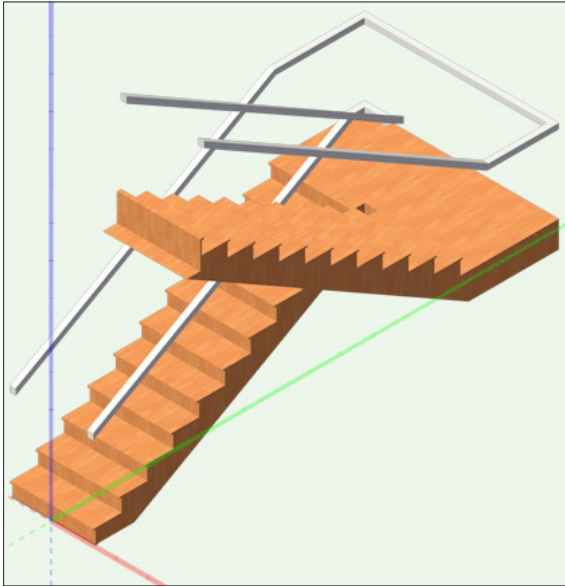

- Using the classes on the Graphic attributes for the stair, allows you to set the textures quickly.

Circular Stairs

[cadmovie876](#)

The stair tool can make circular stairs.

- If you have a stair on the design layer, double click on the stairs. Otherwise, click on the Preferences button on the Tool bar.
- The settings dialog box will open.
- Click on **Select Standard Configuration...** button.
- Click on the **Circular Stair** option.
- Click on the **OK** button.

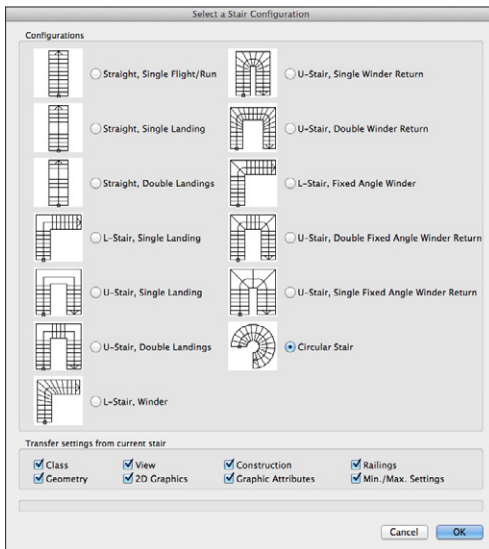

- Click on the **Geometry** tab.
- Enter the **Tread Depth** for tread at the walk line.
- Enter the **Riser Height**.

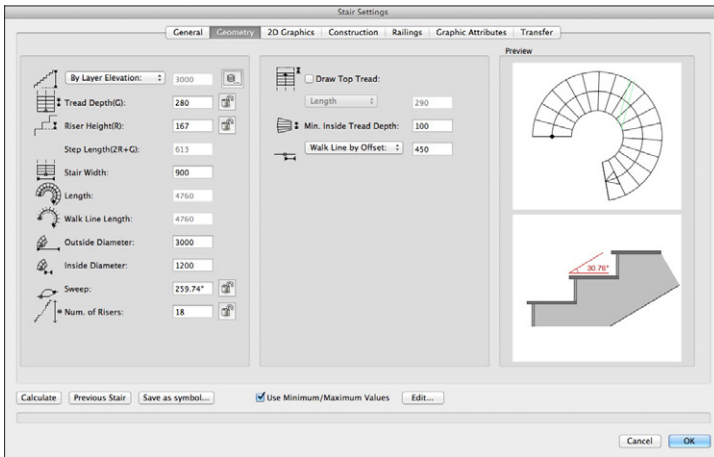

- Click on the **2D Graphics** tab.
- Use your saved styles to quickly set the graphics to suit your way of drawing.

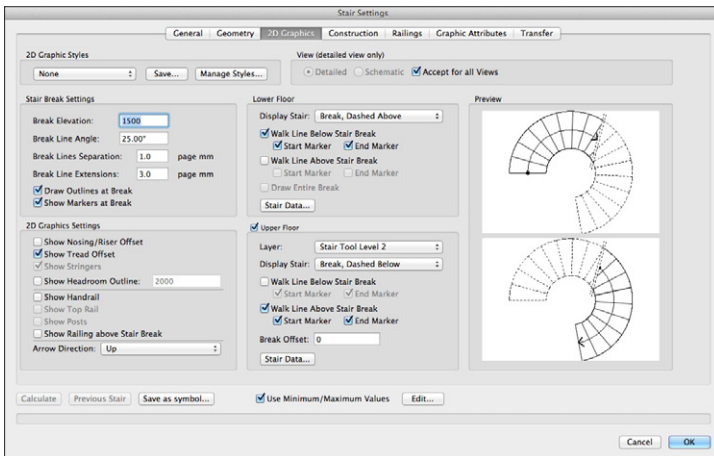

- Click on the **Construction** tab.
- Use your saved styles.

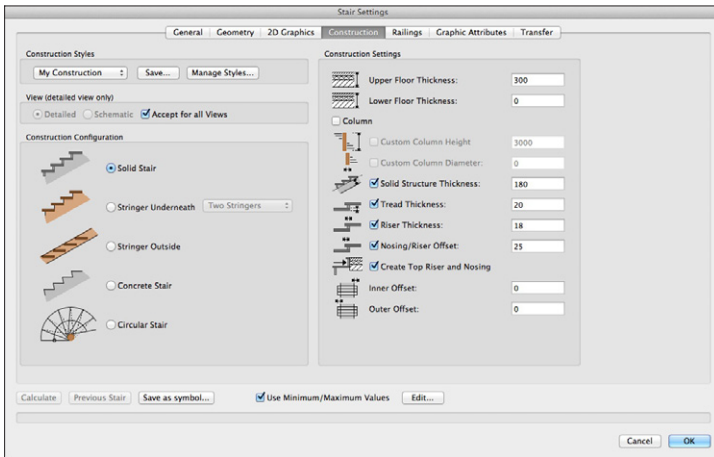

- Click on the **Railings** tab.
- Use your saved styles.

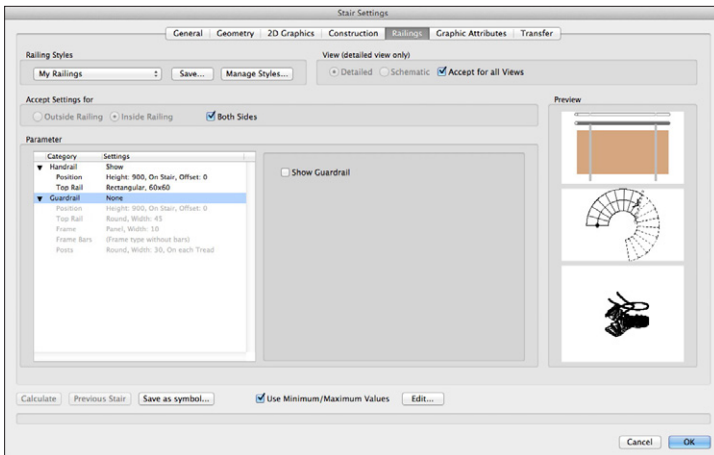

- Click on the **Graphic Attributes** tab.
- Use your saved styles.

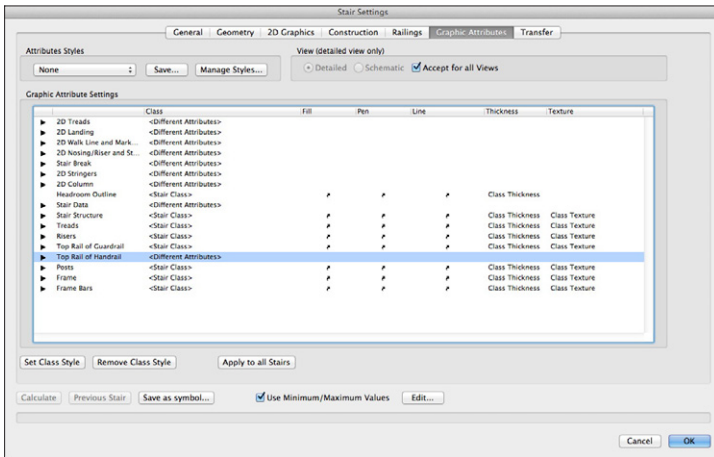

- Click on the **OK** button.
- Click once to place the center of the stair, click once for the rotation of the stair.

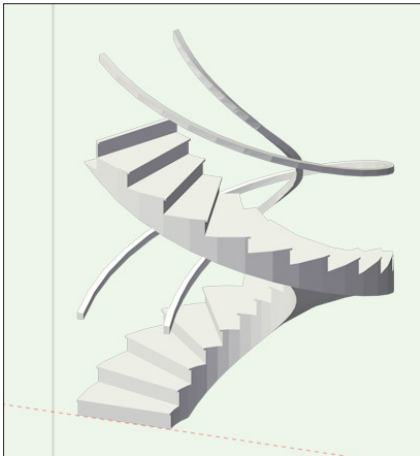

When to Use the Stair Tool.

The is great for what is can do, but there are several things it can't do:

- The stair tool will not create landings or winders at anything other than 90°.

- You can't create complex stairs like this one.
- The stair will only appear on one level.

In these situations, use the Custom Stair.

Thank you

We trust that you have enjoyed working through this manual and that it has been informative and constructive.

For more information, please visit: <http://learn.archoncad.com/>. If you just want someone to help you learn Vectorworks, to carry out some Vectorworks contract work, or you want someone to make Vectorworks easier, contact us, as this is a service that we also offer:
jon@archoncad.co.nz.

Thank you again,
Jonathan Pickup
November 2012