

SHORT SHARP MANUALS
1705
InteriorCAD
XS



archoncad.com
Making Vectorworks easy!
<http://learn.archoncad.com>

Written with
Vectorworks 2017
Revision 0.6

All rights reserved. No part of this book may be reproduced or transmitted in any form by any means, electronic or mechanical, including photocopying, recording, faxing, emailing, posting online or by any information storage and retrieval system, without prior written permission of the publisher.

Vectorworks is a registered trademark of Nemetschek Vectorworks Inc. in the U.S. and other countries. Windows is a registered trademark of Microsoft Corporation in the U.S. and other countries.

Macintosh is a trademark of Apple Computer, Inc., registered in the U.S. and other countries. Adobe, Acrobat and Reader are registered trademarks of Adobe Systems in the U.S. and other countries.

The information in this book is distributed on an “as is” basis, without warranty. While every precaution has been taken in the preparation of this book, the author shall not have any liability to any person or entity with respect to any loss or damage caused or alleged to be caused directly or indirectly by the information contained in this book or by the computer software described in it.

For more Vectorworks training information, or to purchase more copies of this book, please email jon@archoncad.com

Contents

Introduction..... 4

Beginner Topics 5

 Classic Cabinet..... 5

 Cabinet 3D 31

Introduction

InteriorCAD XS is a plug-in for Vectorworks. In fact it is a suite of plug-in tools. It does not come as a standard installation, it is something that you have to purchase in addition to Vectorworks.

Vectorworks 2017 has a new custom cabinet tool that is a derivative of InteriorCAD. Interior CAD comes in two suites, InteriorCAD XS that we will be looking at in the fuller more complex version for kitchen manufacturing called InteriorCAD. In this manual we will only be looking at InteriorCAD XS.

Vectorworks comes with basic cabinets and the custom cabinet mentioned above. These are often enough for some designers. Some designers want to have more flexibility in their ability to design cabinetry. In this case InteriorCAD XS is a good solution.

There are two main tools with InteriorCAD. There is a classic cabinet tool which will only work on the Windows version of Vectorworks and the custom cabinet that will work on both the Macintosh and Windows versions. Classic cabinets cannot be converted to custom cabinets.

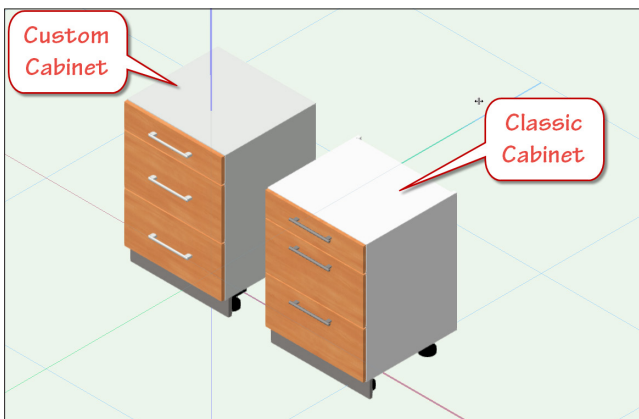

In the basic part of this manual we will look at both the classic and the custom cabinet. We will look at the way you create the design of the cabinet, the construction, the back, and the plinth (kick). in order to explain the way you design cabinets, we will create a series of kitchen cabinets using the classic cabinet tool in the custom cabinet tool.

In the intermediate part of this manual we will look at the construction, materials, and textures for both the classic and custom cabinets.

Beginner Topics

cadmovie1705-01

Classic Cabinet

Basic Concepts

InteriorCAD is a powerful addition to Vectorworks, but if you do not understand the basic concepts, you could find the dialog boxes confusing.

In order to tell InteriorCAD where to put drawers and doors, you need to divide up the cabinet into what are called divisions. With the classic cabinet there are horizontal and vertical divisions and you choose these through an icon in the dialog box.

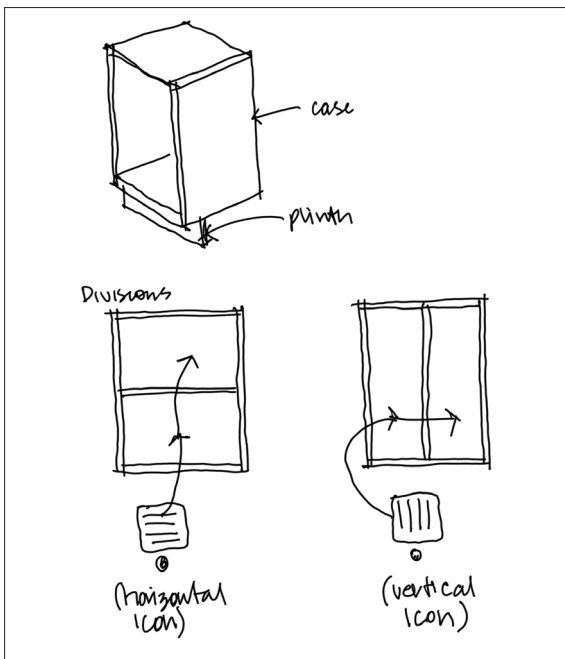

- For creating a three drawer unit for example you would need three horizontal divisions, one for each draw.
- For creating a unit with a drawer at the top and two drawers at the bottom, you would require two horizontal divisions. One division for the draw the top and one division for the double door at the bottom.

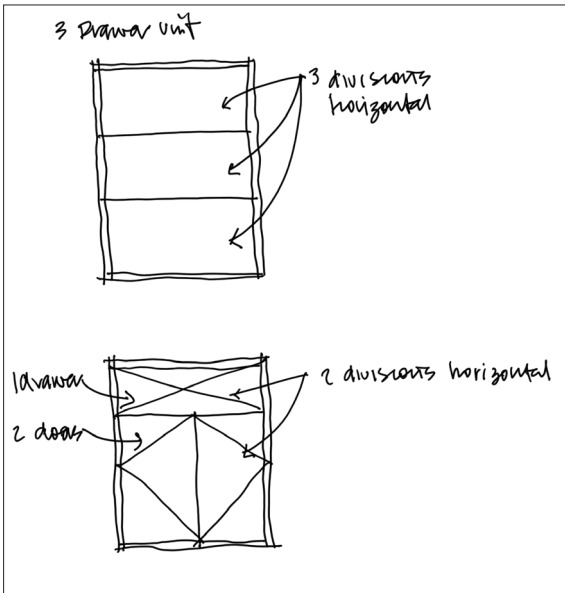

- When you install InteriorCAD you will get a new InteriorCAD XS toolset.

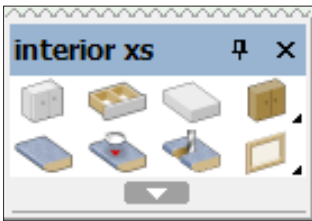

- The classic cabinet is controlled by a main dialog box called **Create Unit...** This dialog box has buttons to control specific parts of the cabinet.

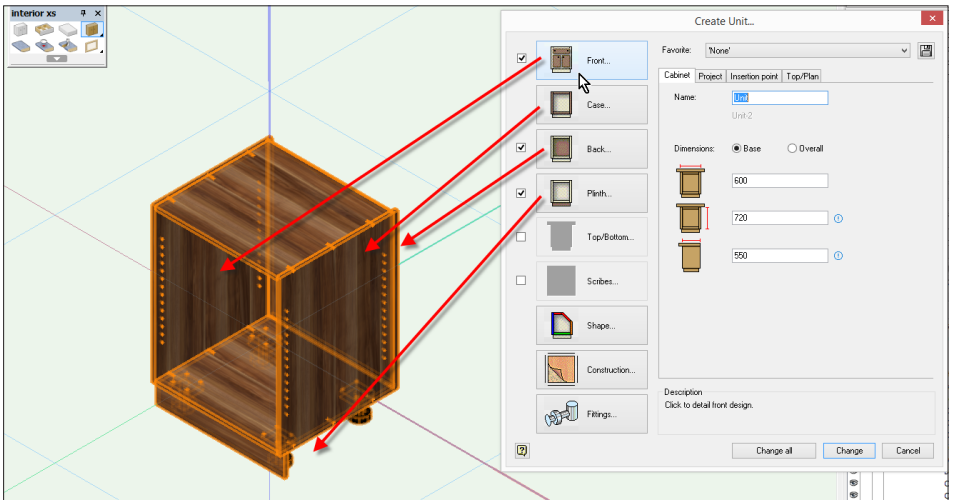

3 Drawer Unit

- Select the Cabinet 3D (Classic) Tool.

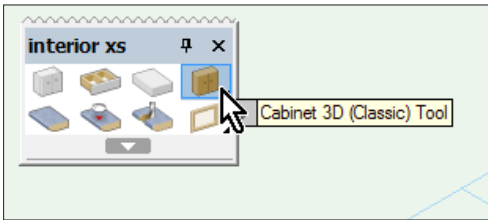

- Move your cursor into the drawing area and double-click to place a cabinet.
- Go to the **Object Info** palette.
- Click on the **Edit...** button.

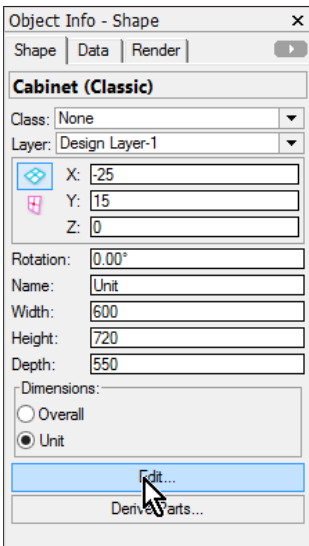

- This will open the **Create Unit...** dialog box. This is where you will do most of your editing. You could think of this as the command center for editing your unit.

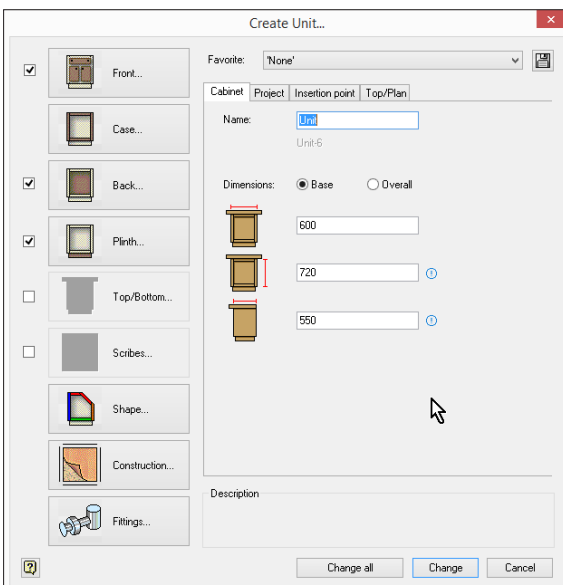

- Click on the **Front** button.
- This dialog box has seven different tabs that are used to control the design of the front of the unit.
- The main part of the design will be carried out with the **Division** tab.

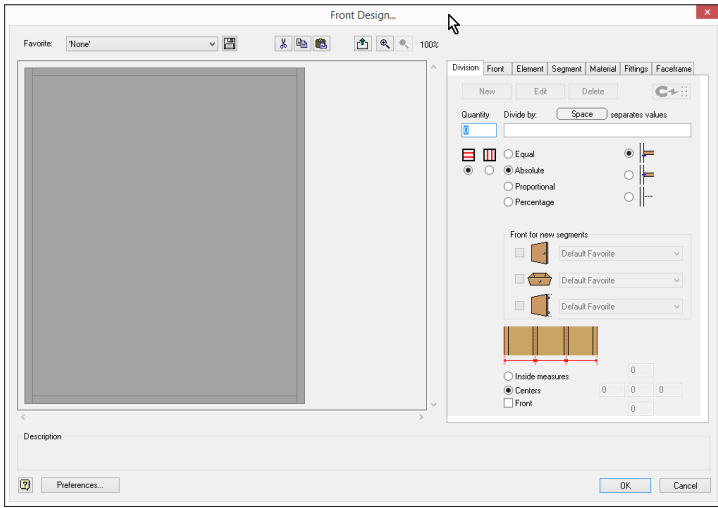

- Now is time to create the divisions.
- For the quantity, type in **3**.
- The **Divide by** controls the size of the divisions.
- Type in **0 0 150** (6in).
- This is code. The 0 means use the remainder. So typing in two 0 and the specific dimension means that we want to use the specific dimension at the top (because it is the last number) and two equal remaining divisions for the rest of the unit.

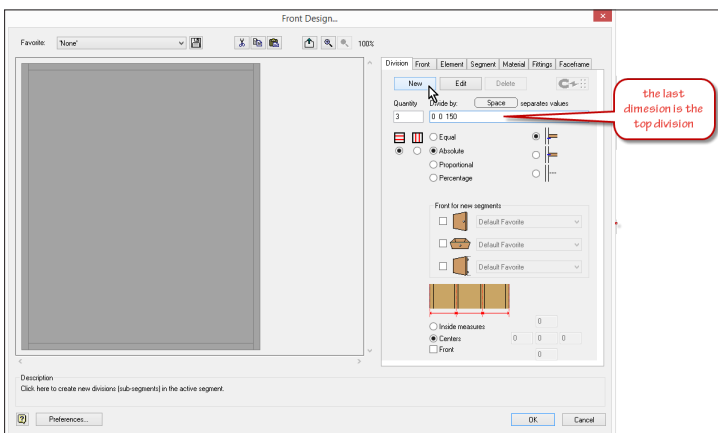

- Click on the **New** button create the divisions.
- At the moment you have three divisions and in division separated by an adjustable shelf.

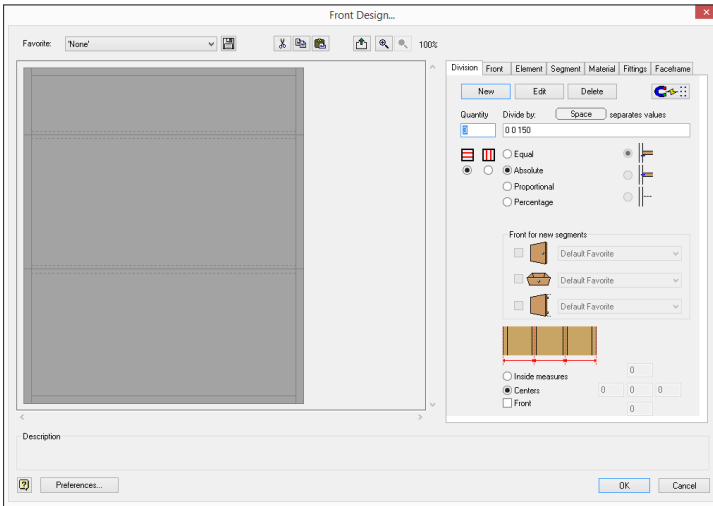

- Each division can be edited separately and the shelves between the divisions can also be edited
- Move your cursor to the top division and click once.
- This division will highlight.

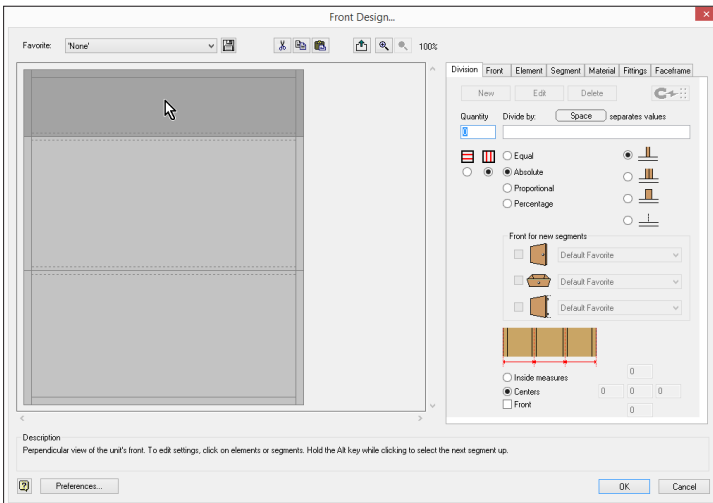

- Move your cursor to the middle division and click once.
- This division will highlight.

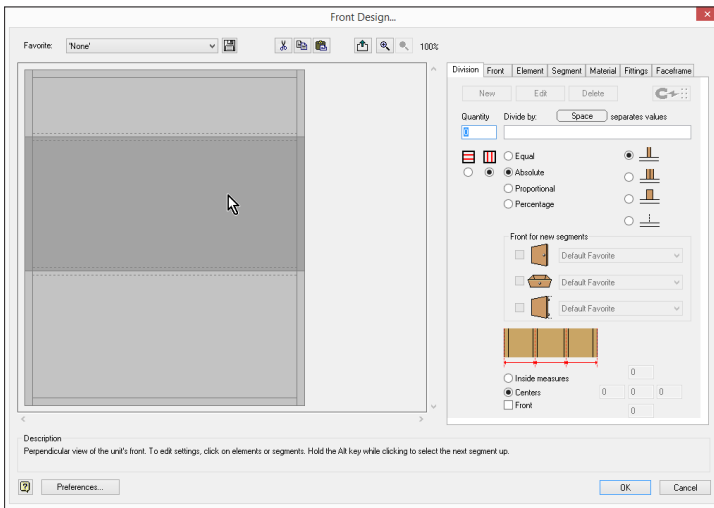

- Move your cursor to the shelf separating the top and middle divisions.
- Click once.
- This shelf will highlight.

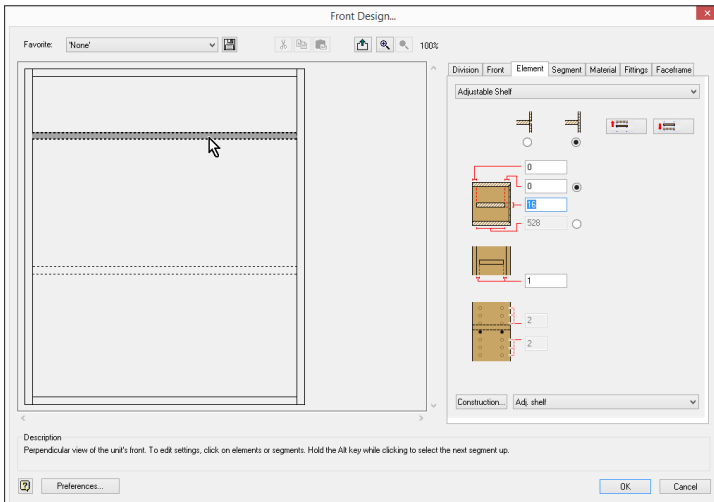

- The element tab should be the active tab, this is the one controls the shelving.
- From the pop-up menu choose **None**.

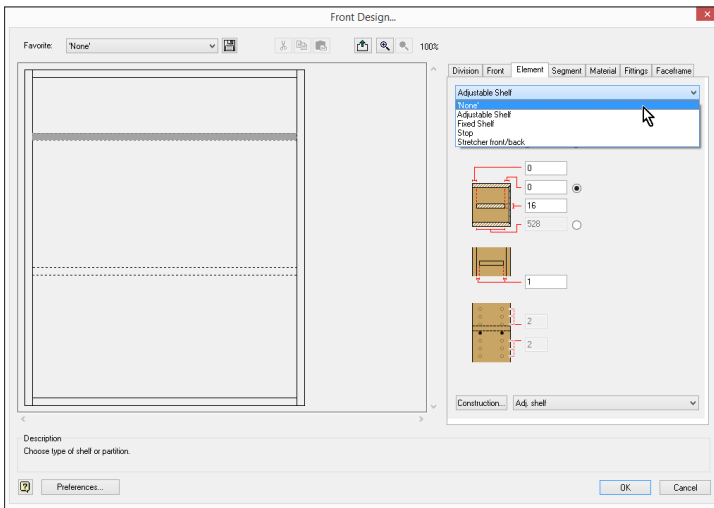

- This will remove the shelf and replace the division with an empty element. We will be putting drawers in these areas which means that we do not need to have shelving between each drawer.

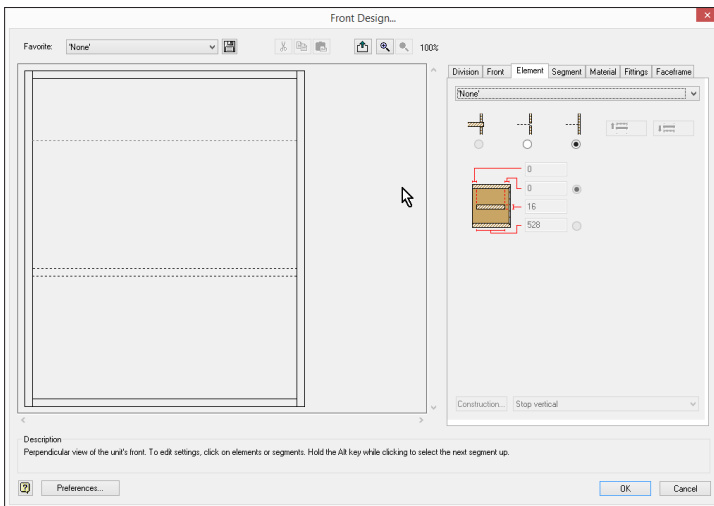

- Select the next shelf.
- From the pop-up menu choose None. We also want to remove the shelf.
- Move your cursor to the top division and click once.
- This division will highlight
- The **Front** tab should be activated. If it is not click on the Front tab.

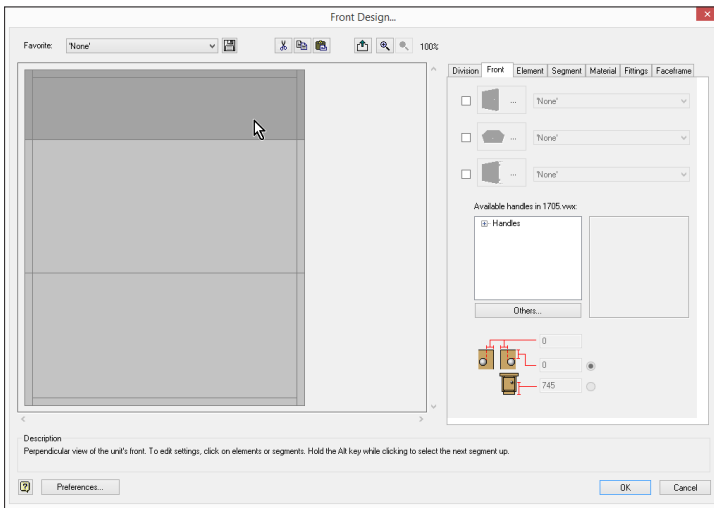

- We will be creating this into a drawer.
- The draw option is the third button down.
- Click on the tick next to the draw option.

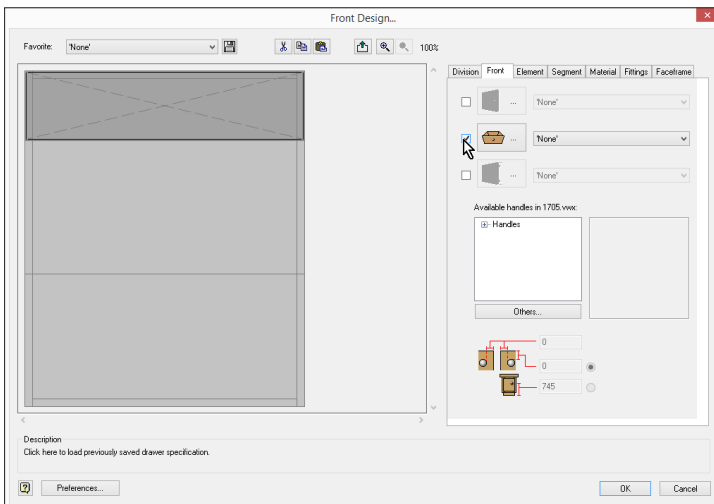

- In my file I already have drawer handles imported. If you do not have drawer handles in your file, click on the Others... button to import drawer handles from the defaults.

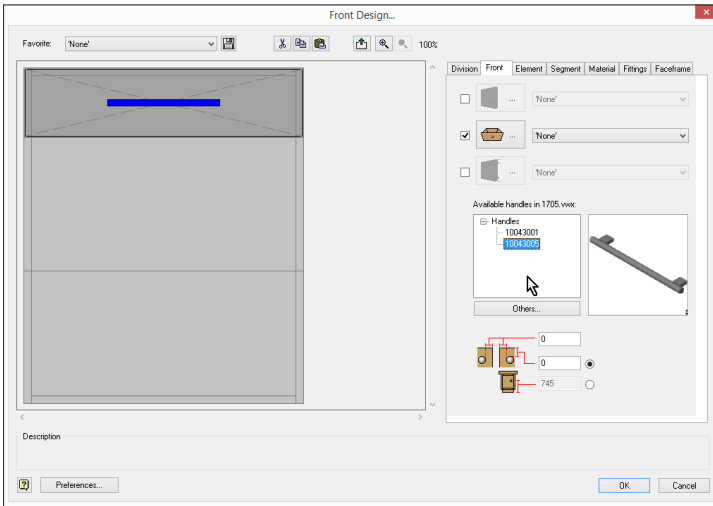

- Highlight each of the other divisions, create them into drawers and assign the drawer handles.

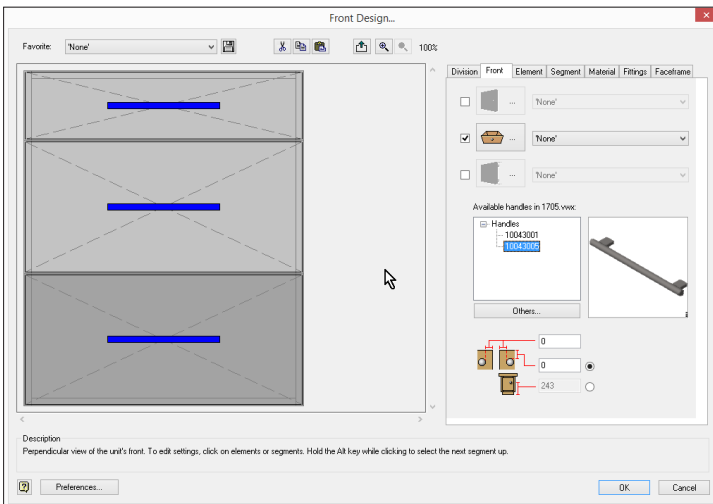

- Click on the OK button to return to the **Create Unit...** dialog box.
- Edit the name of the unit.

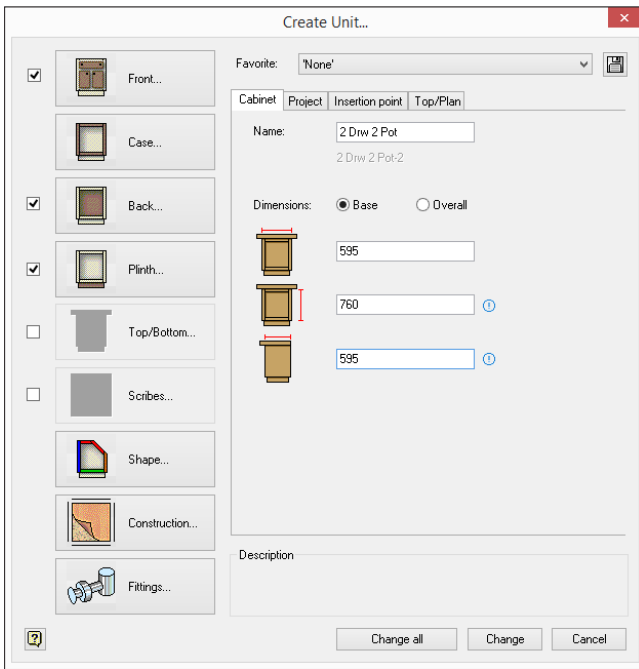

- Edit the size of the unit if required.
- Click on the Change button to change the unit and return to the drawing.

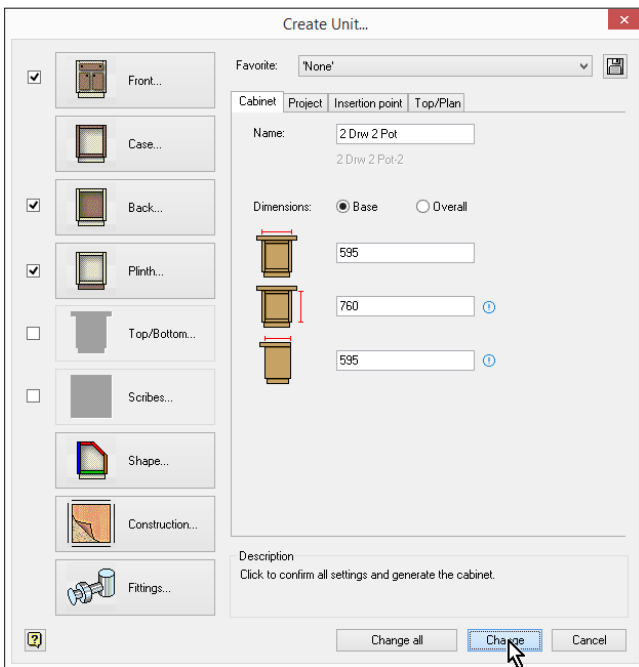

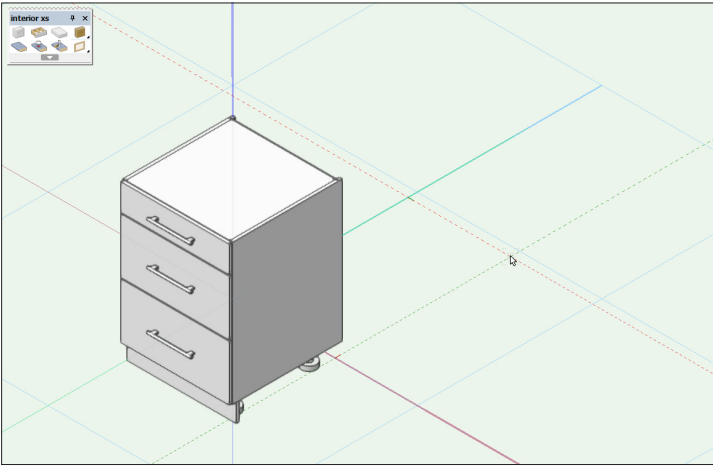

- Ensure the object is still selected.
- Go to the **Object Info** palette.
- Click on the **Edit...** button.
- Click on the **Case...** button.

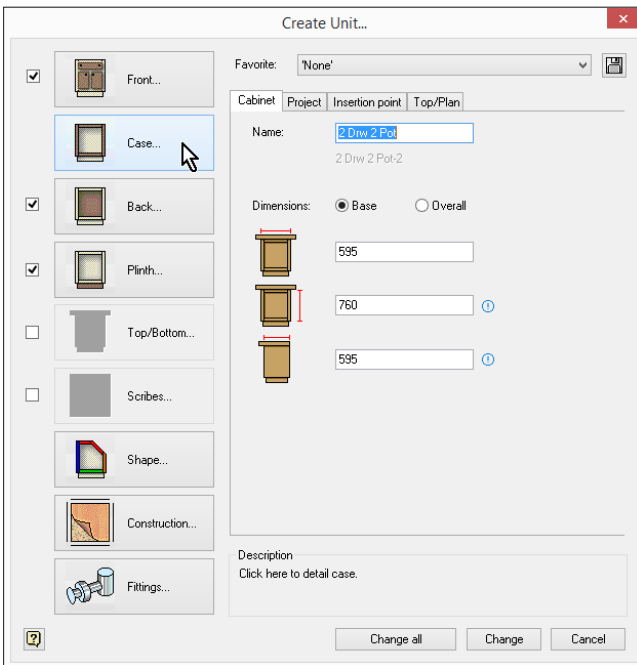

- This will open a dialogue box allowing you to control the construction of the carcass.
- There are several options here for controlling the construction of the carcass. You can control the thickness of the material, the construction of the sides, the construction of the top, whether you are using stretchers, and the details for the offset of the sides.
- This dialog box also gives you the ability to turn sides on or off by

clicking on them.

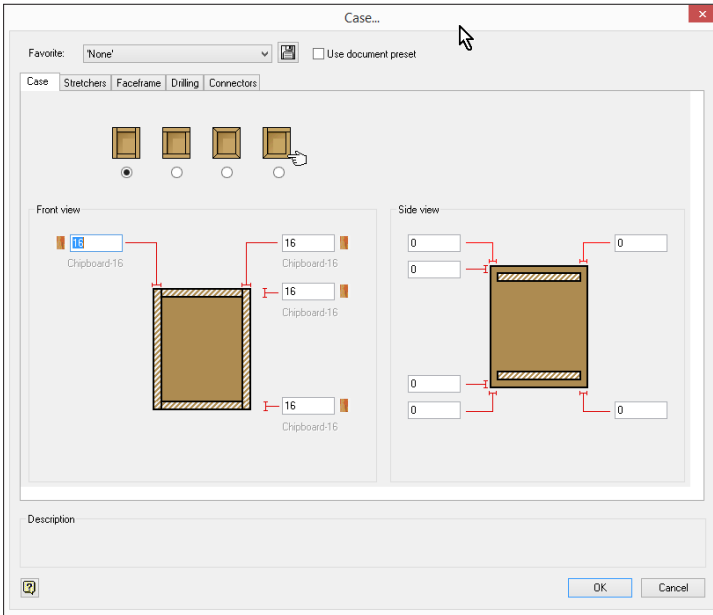

- Set the required construction options.
- Click on the **OK** button to return to the **Create Unit...** dialog box.
- Click on the **Back...** button

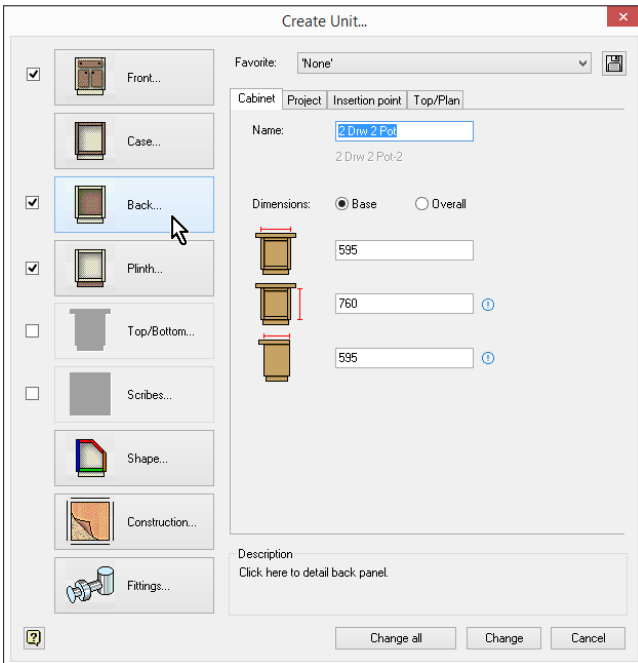

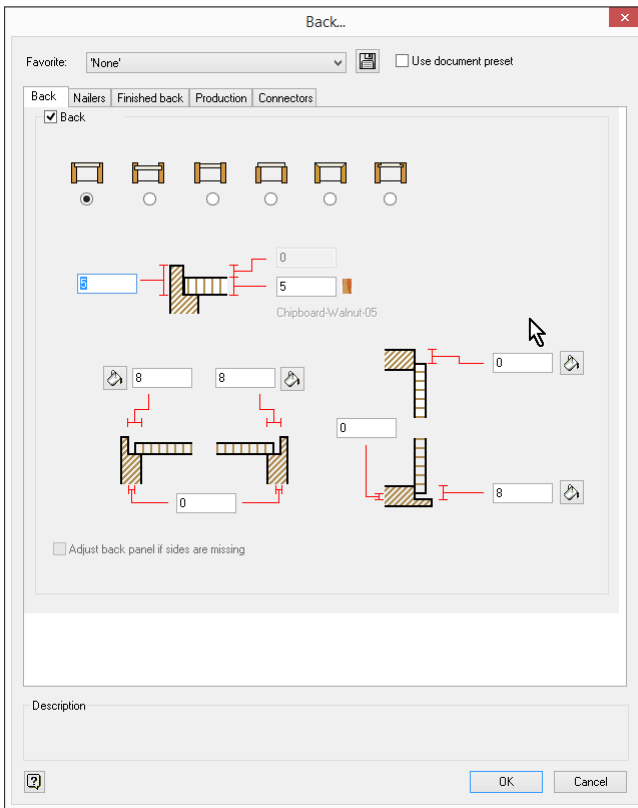

- Click on the **Back...** button
- There are several options here for controlling the construction of the back. You can control the thickness of the material, the construction of the back, etc.
- Set the required construction options.
- Click on the **OK** button to return to the **Create Unit...** dialog box.
- Click on the **Plinth...** button.

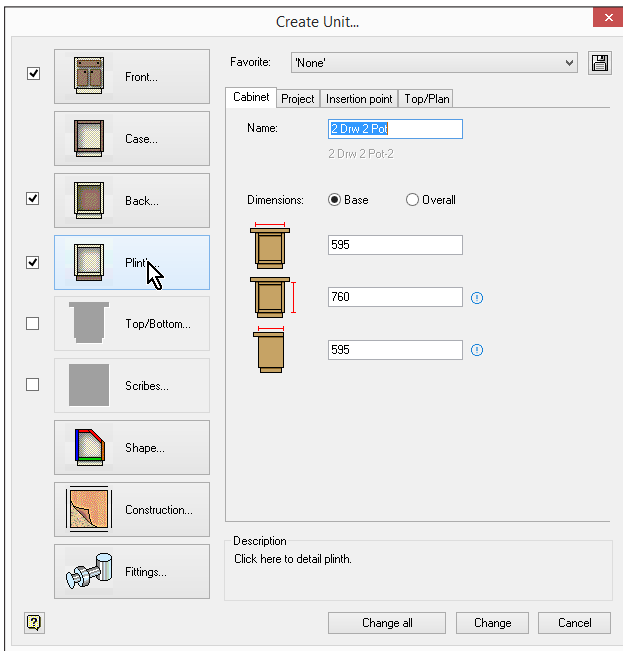

- There are several options here for controlling the construction of the plinth. You can control the thickness of the material, the construction of the plinth, etc.
- This dialog box also gives you the ability to turn sides on or off by clicking on them.
- Set the required construction options.

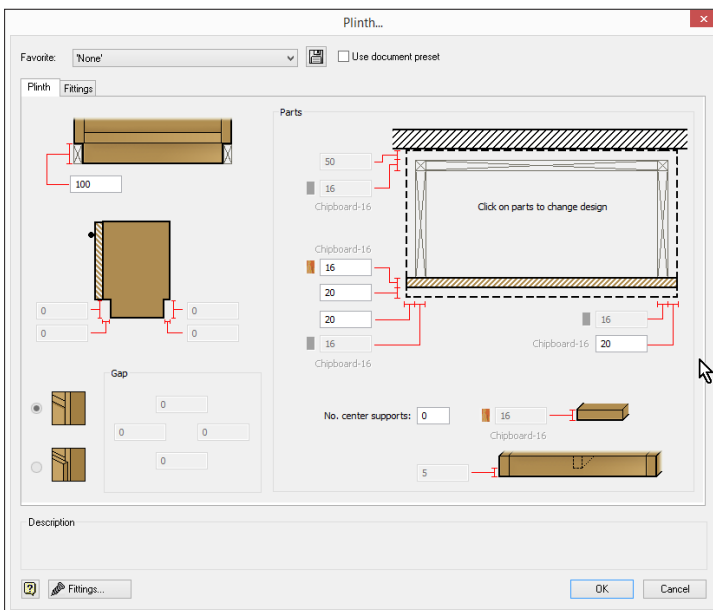

- Click on the **OK** button to return to the **Create Unit...** dialog box.
- Now that we have spend so much time working on the unit, the size, and construction, it would be good to be able to save the settings.

- One of the advantages of saving your favorite design is that you can use the same design on another file. You could think of this as building a library. Having a favorite site is very very efficient way of building your InteriorCAD units.

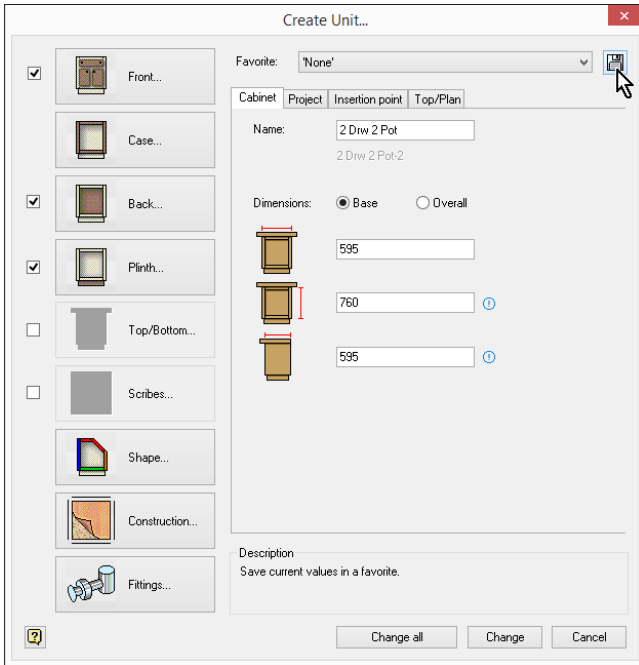

- Click on the **Save** icon.
- Name your favorite unit.

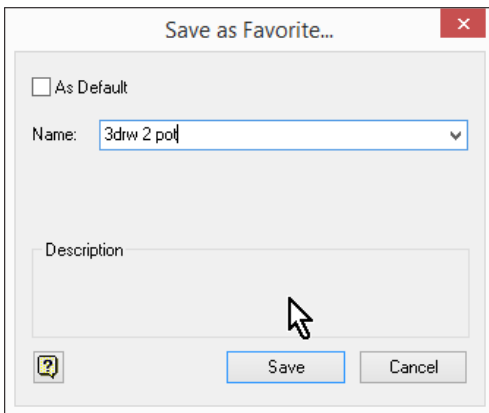

- Click on the **Save** button.
- The next time you create a unit you will be able to use this favorite to create the entire cabinet.

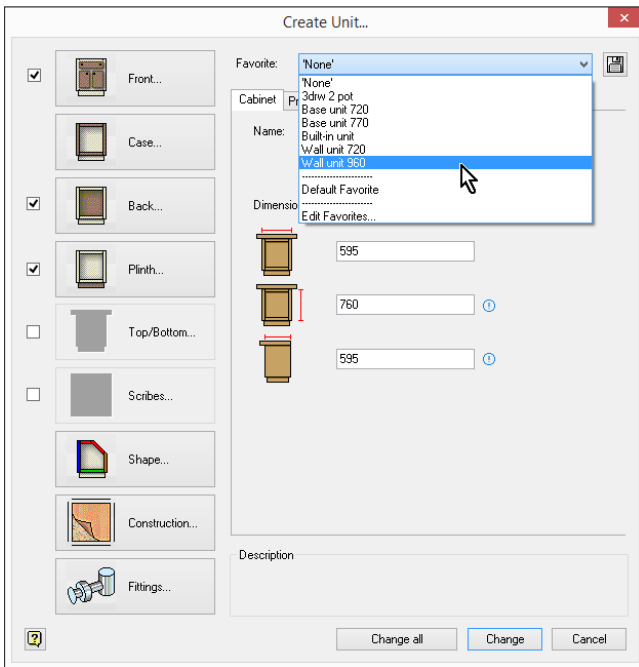

- Favorites can also be saved for individual parts of the cabinet.
- For example, you can save the front design of your 3 drawer unit so that you can reuse this design on other cabinets.

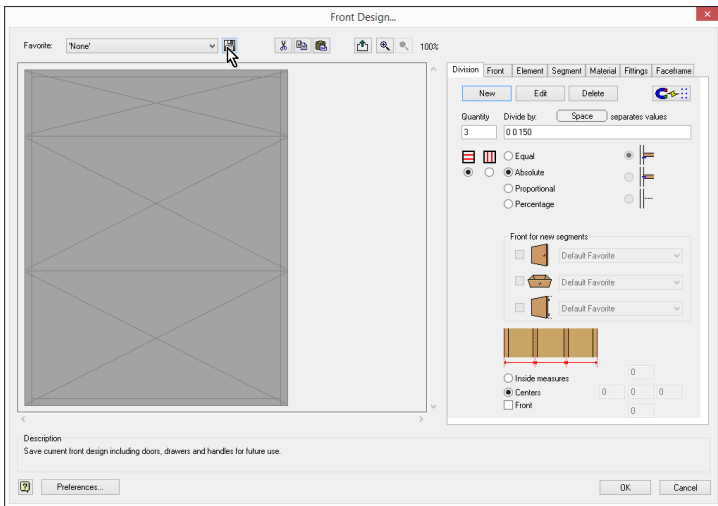

- Favorites can also be saved for individual parts of the cabinet.
- For example, you can save the front design of your 3 drawer unit so that you can reuse this design on other cabinets.
- On the **Front Design...** dialog box, click on the **Save** icon.
- Name your front design favorite.

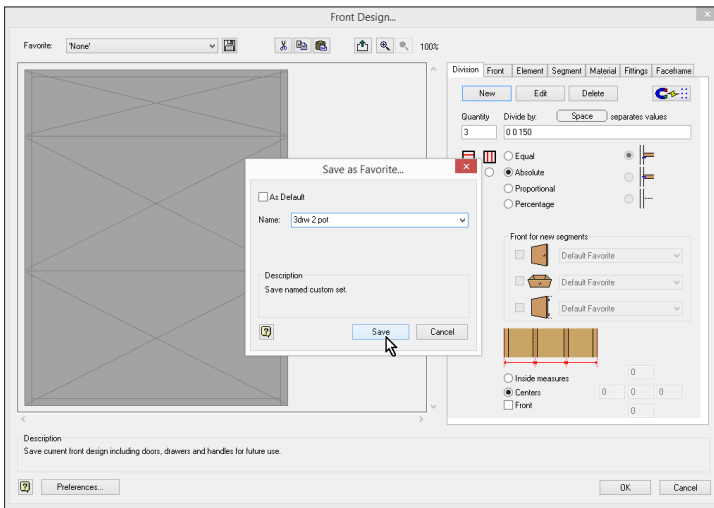

- Click on the **Save** button.
- The next time you want to reuse this front design, you can recall it from your list of favorites.
- These favorites allow you to quickly jump between one front design and another.
- In this example I have selected the adjustable shelving.

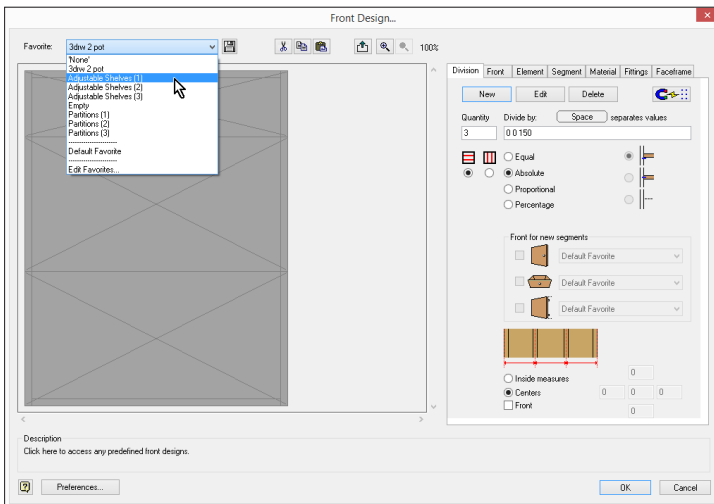

- After selecting the shelving from my favorite you will notice that all of my drawers have been replaced with one shelf.

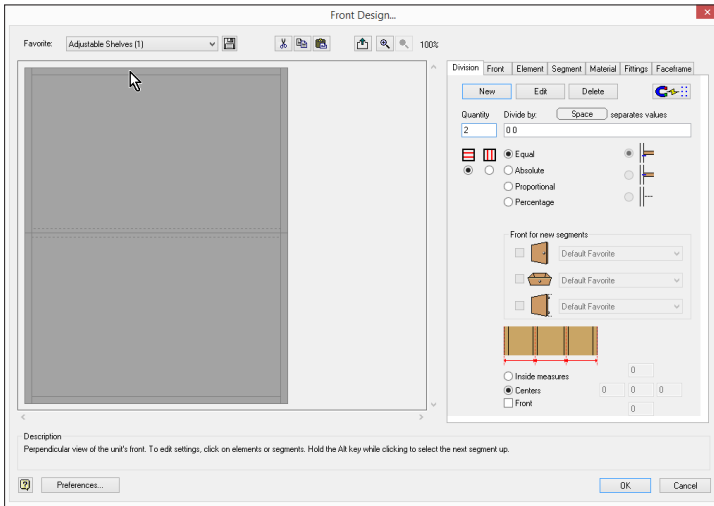

- Now I can go back to my favorites and select my 3 drawer front design.

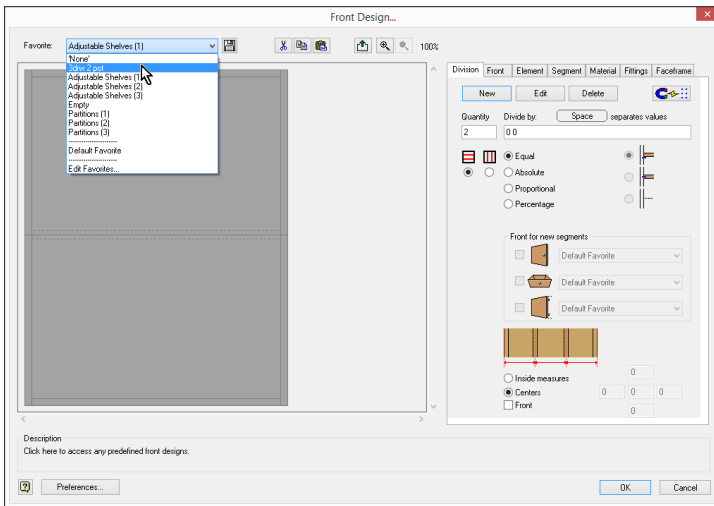

- You will notice that all of my drawers have been put back in.

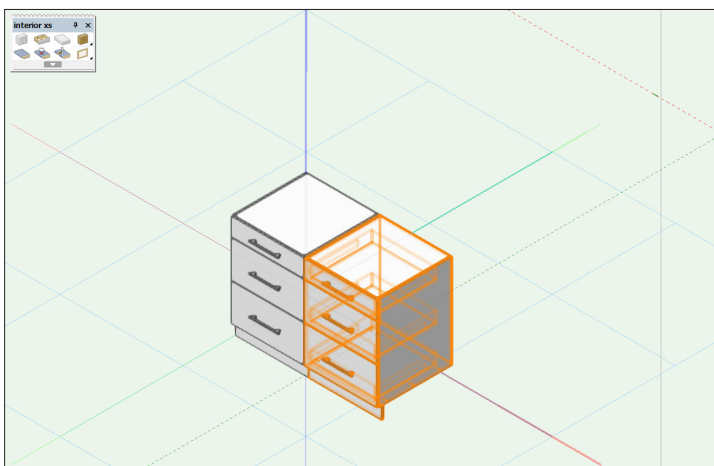

- You can also use the favorites in conjunction with the **Front Design...**

button on the Object Info palette.

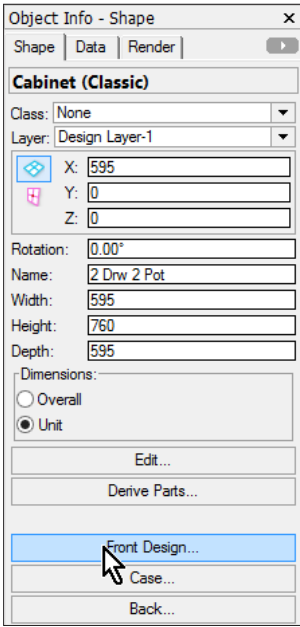

- This makes it very quick to change the front design for your units without changing the overall size of the cabinet.

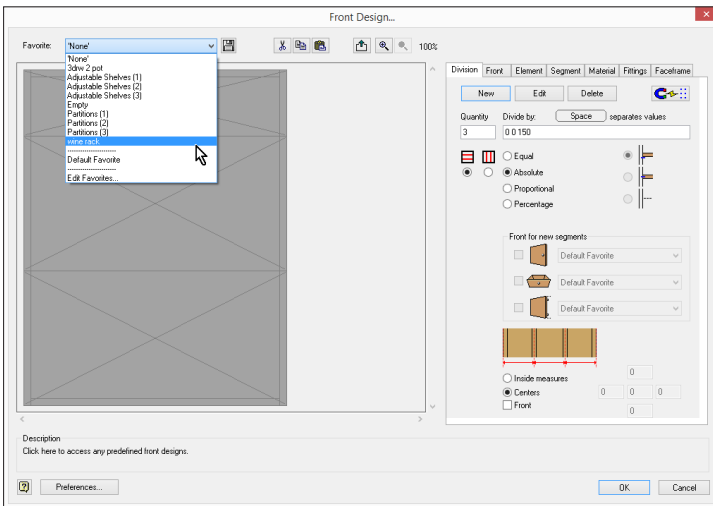

- When you click on the **OK** button the front design will be applied to your unit and it will be updated. This technique will not change the size of the unit, it changes the front design.

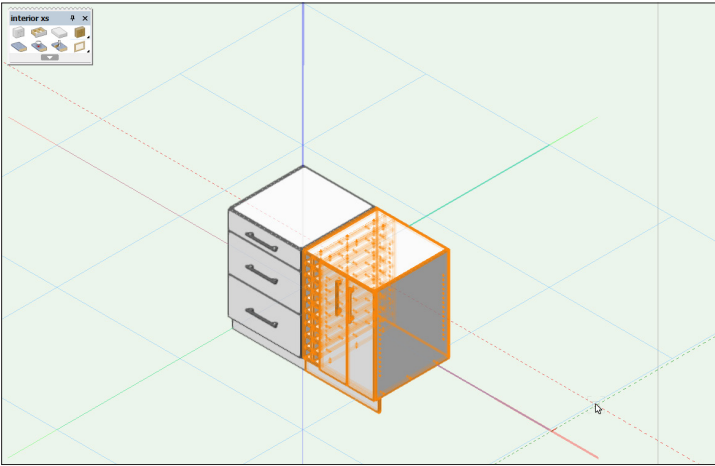

Front Design Editing Tricks

When you are creating a front design that has a repeating parts, you can copy and paste divisions from one place to another.

On the **Front Design...** Dialog box are three buttons for cut, copy, and paste.

- The first button is cut.

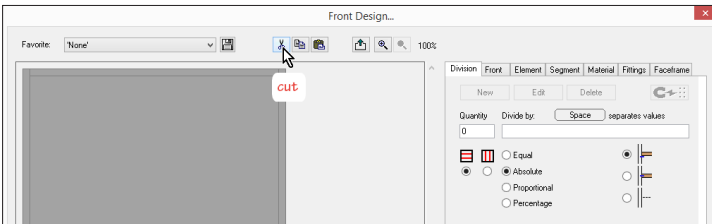

- The second button copy.

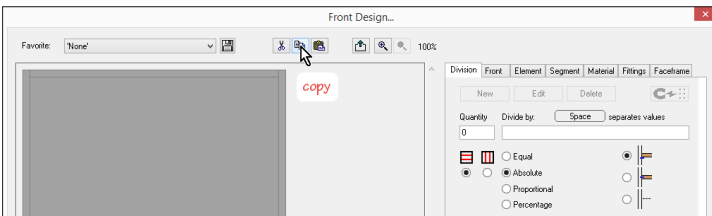

- The third button is paste.

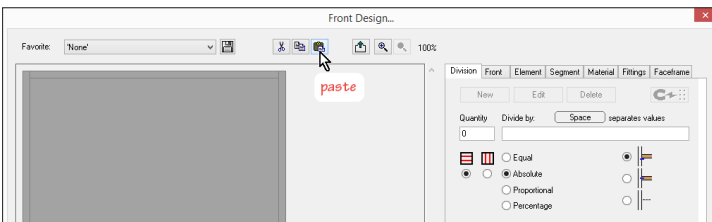

1 Drawer, 2 Door Unit

The previous example demonstrated most of the parts of creating a single InteriorCAD unit. This unit is an example of how to add drawers and doors. For this particular unit I am going to focus on the Front Design dialog box.

- Start by creating a classic cabinet and editing the Front Design...
- Create two horizontal divisions with the top division being 150 mm (6 inches).

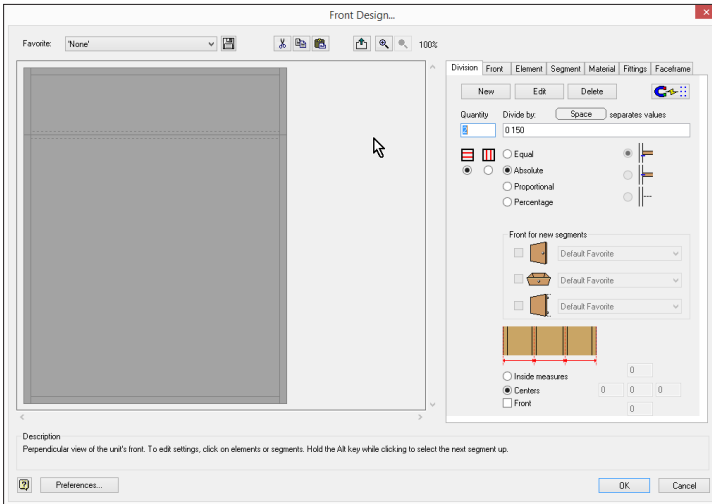

- Click once in the top division.
- Go to the Front tab and make that division into a draw with a specific handle.

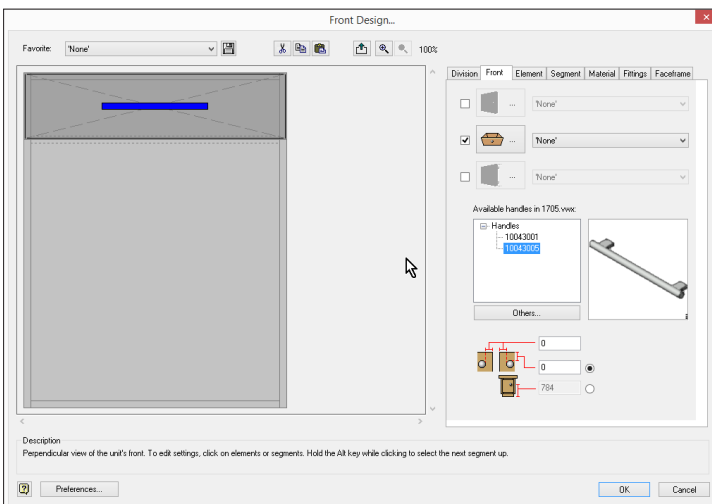

- Click once in the bottom division.
- Go to the **Front** tab and click on the text box next to the door (the top option).

- Click once on the door button open up the **Door...** dialog box. This dialog box is the control center for creating doors. You can create flush doors, paneled doors, by folding doors, sliding doors, overlay doors, inset doors, etc.
- An important part of this dialog box is the ability to control the offsets for the door sides, top, and bottom relative to the carcass.

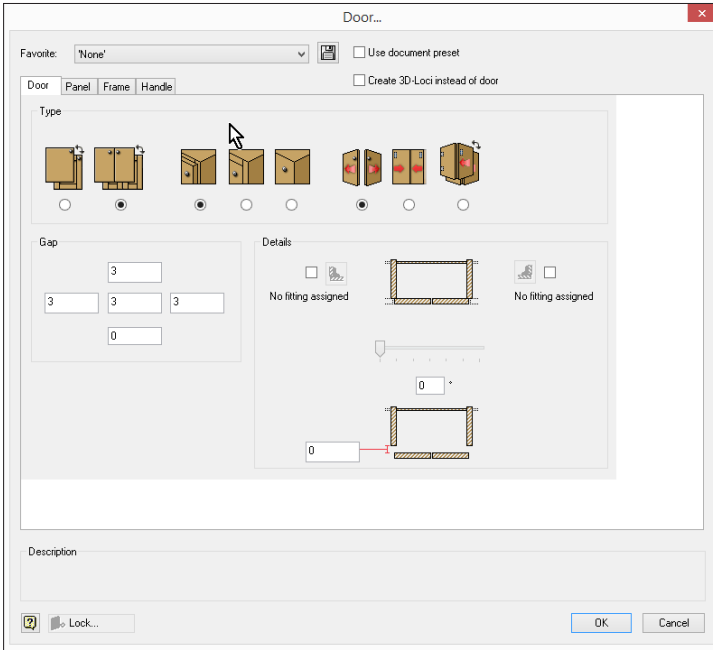

- Click on the tab for **Handle**.

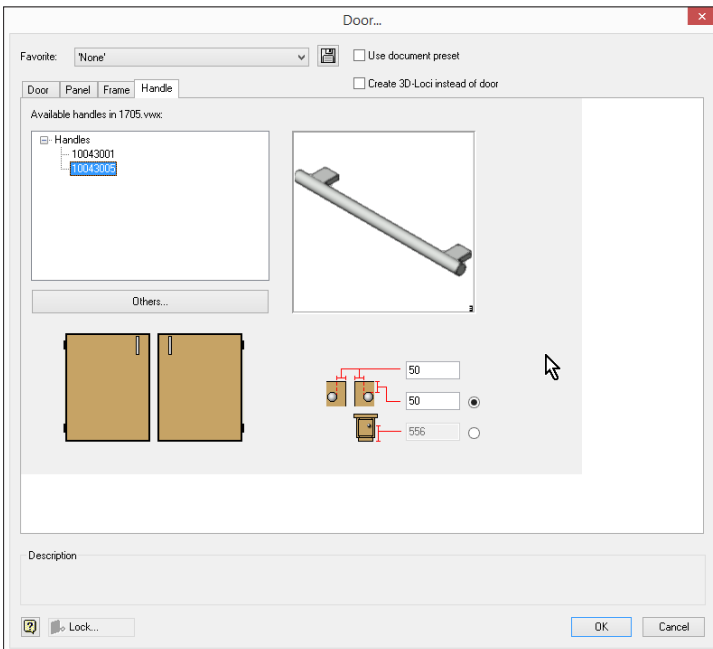

- This part of the dialog box allows you to choose the handle, the location of the handle, and the dimensions for the location.

- Click on the door for the location of the handles (top left, top right, center, etc.).
- If you click on the handle again, the handle will rotate 90°.
- If you click on the handle once more the handle will be turned off.
- Once you have placed the handle in the correct location, adjust the offsets from the edge accurately using the dimensions.
- If the setting out of these doors is common, then click on the save icon to save this as a favorite. This could save you a lot of time in the future setting out the doors again.

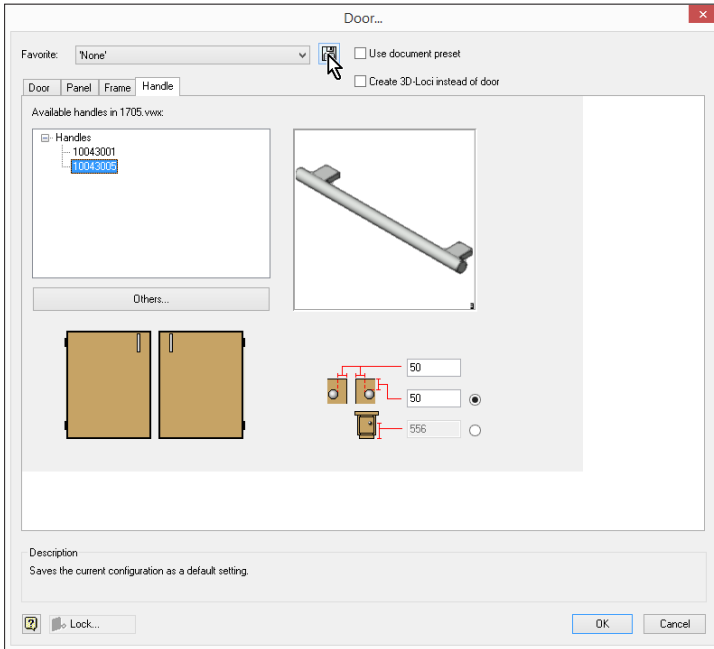

- Name your favorite to make it easy to remember.
- Click on the **Save** button.

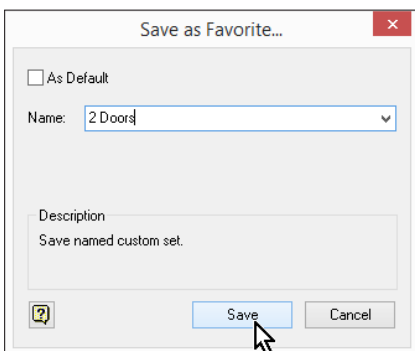

- Next time you want to install double doors with these vertical handles, you will be able to choose your favorite from the Front Design... dialog box by using the pop-up menu next to the door icon.

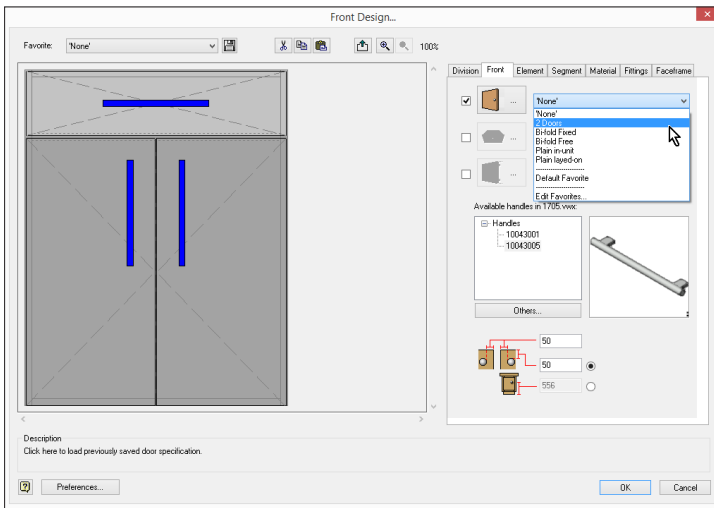

- Click on the **OK** button to return back to the **Create Unit...** dialog box.
- Name the unit.

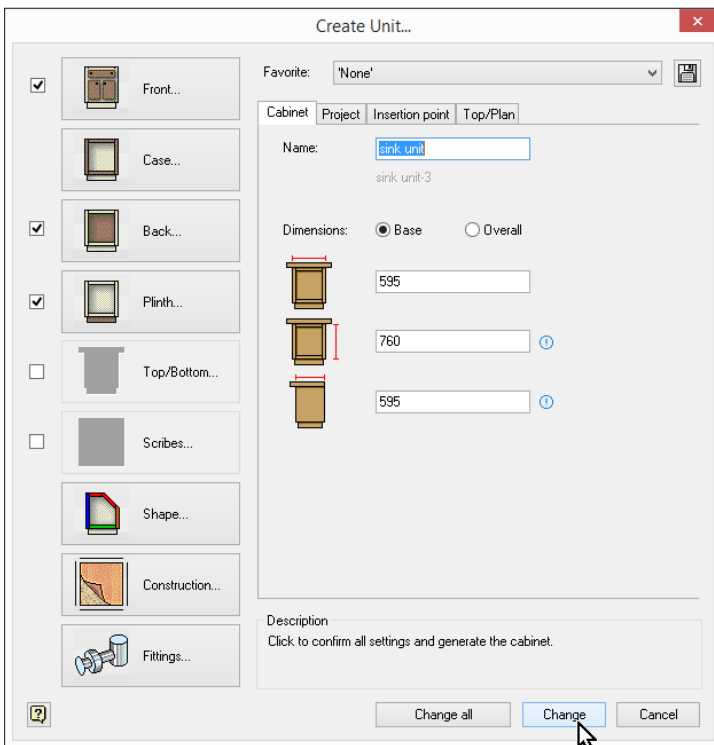

- Click on the **Change** button to return back to the drawing.
- Another productive technique is saving this unit as a symbol.
- Select a cabinet.
- Go to the **Object Info** palette.

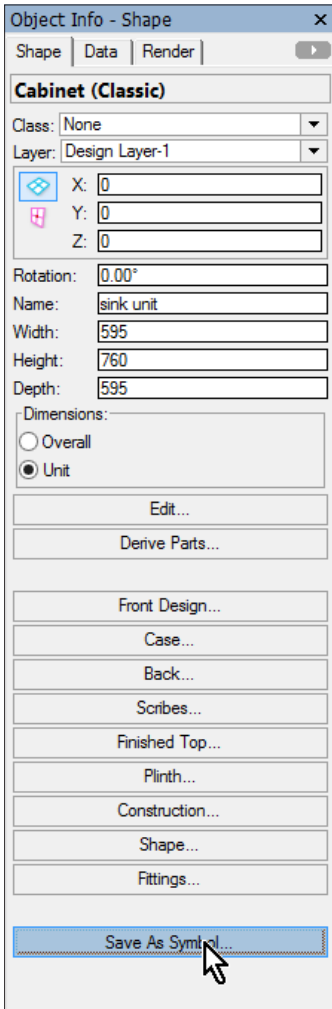

- Near the bottom of the palette is a Save As Symbol... button. Click on this button to save your unit as a symbol.

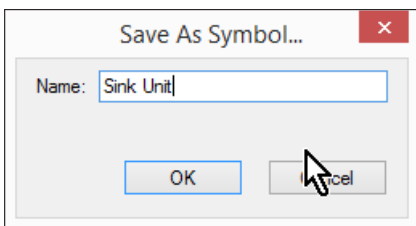

- Name the symbol.
- Click on the **OK** button.
- The symbol appears in the Resource Manager. In this example I have saved my cabinets into a symbol folder to make them easier to find.

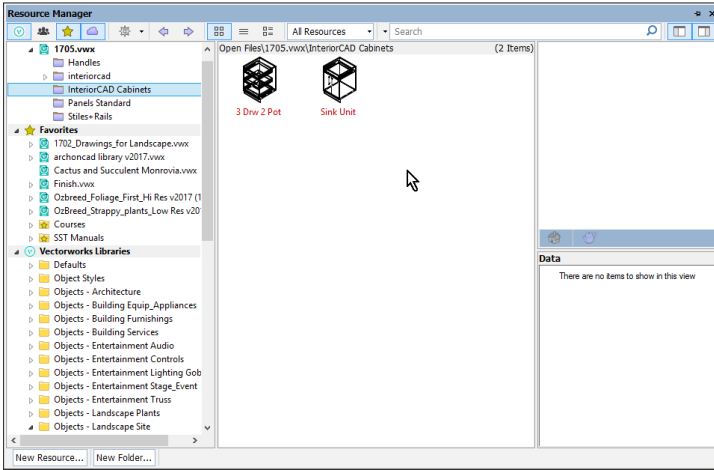

Cabinet 3D

Basic Concepts

The cabinet 3D object is often referred to as the Custom Cabinet. It uses a similar principle to the classic cabinet, but instead of calling the divisions horizontal and vertical, they are known as boxes (horizontal) and columns (vertical).

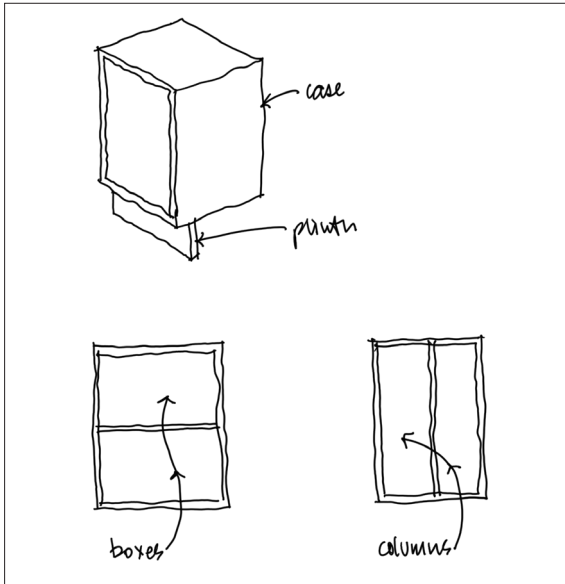

- For creating a three drawer unit for example you would need three boxes (horizontal divisions), one for each draw.
- For creating a unit with a drawer at the top and two drawers at the bottom, you would require two boxes. One box for the top drawer and one box for the double doors at the bottom.

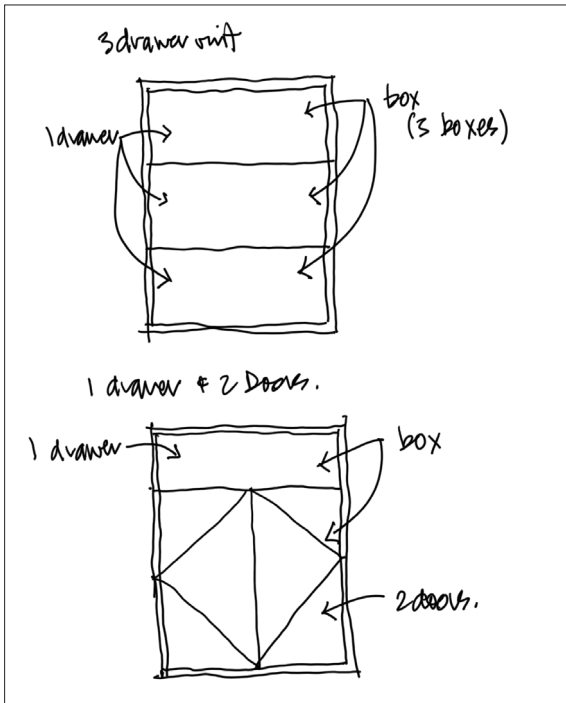

There are some other differences as well. For example, the custom cabinet does not use the concept of favorites to store front designs and constructions. But in many ways, when you have learned to use the classic cabinet you will find the custom cabinet easy to understand.

- Select the **Cabinet 3D Tool**.

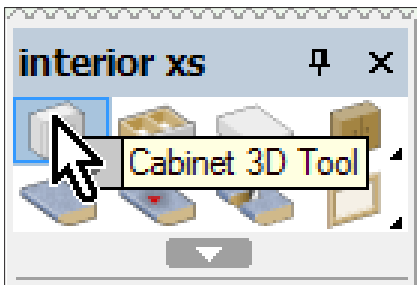

- Move your cursor into the drawing area and double-click to place a cabinet.

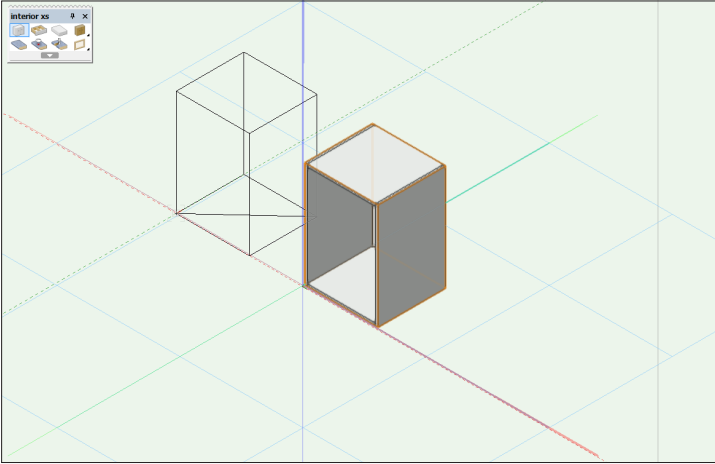

- Go to the **Object Info** palette.

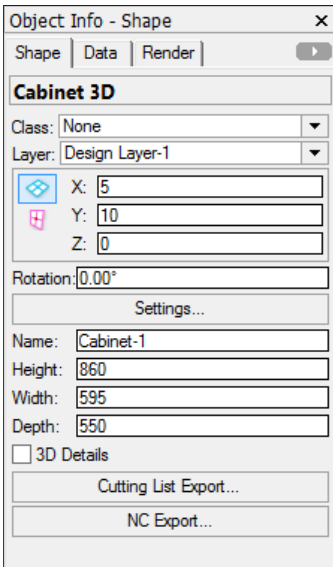

- Click on the **Settings...** button.

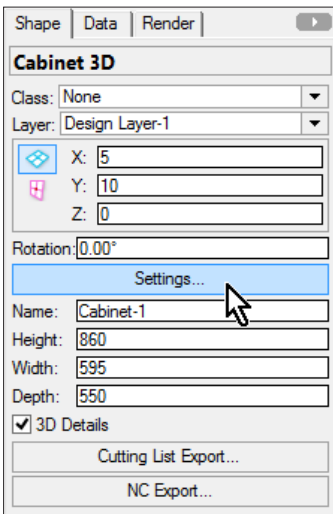

- This will open the **Settings...** dialog box. This is where you will do most of your editing.
- The dialog box is divided into seven sections, you can see these sections on the left.
- The first main part of this dialog box is the **Base**. The base is used to control the class, height, width, depth, type, and the construction of the carcass.
- Put in the correct size and construction.

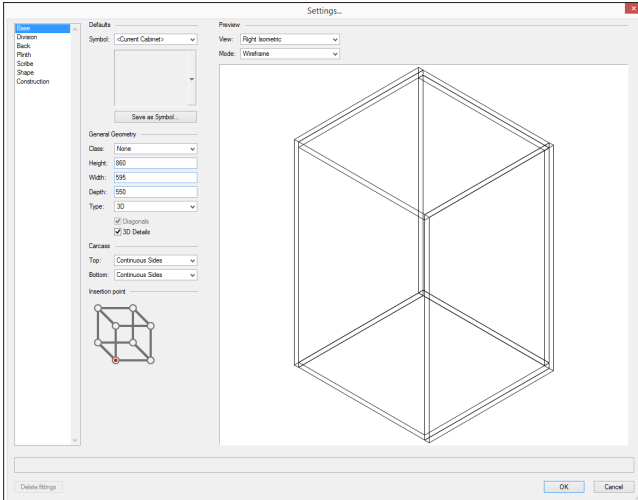

- On the list of options on the left side, click on **Division**.
- The division is similar to the front design in the classic cabinet. In other words this is where you divide your cabinet into parts and assign drawers, doors, shelving, etc.
- Instead of using divisions horizontal and vertical uses the concept of box and column.

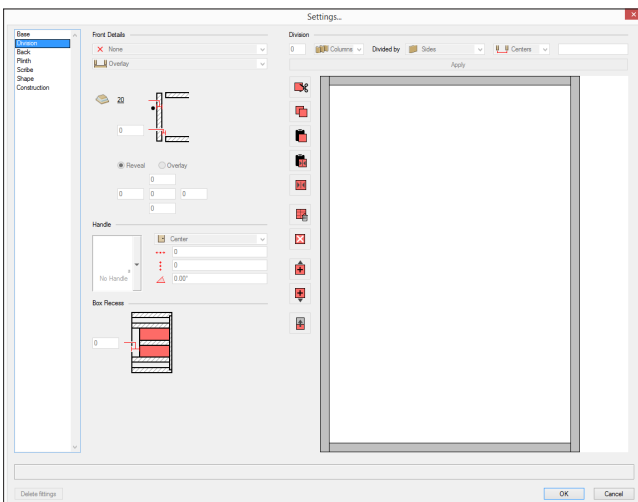

- Instead of using divisions horizontal and vertical uses the concept of box

and column.

- Click once in the center of the unit.
- The entire front of the unit should highlight in red.

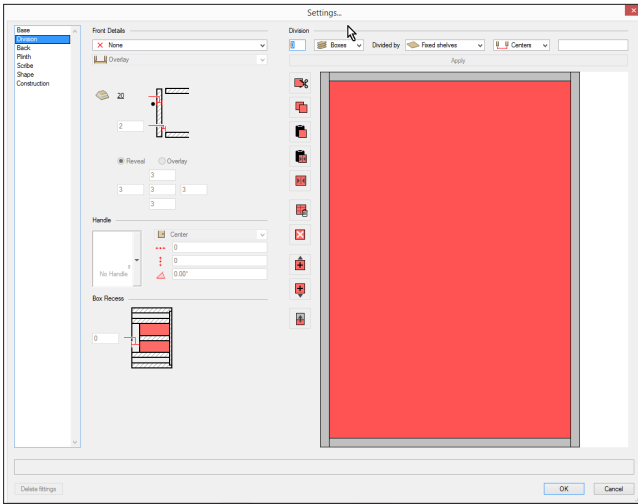

- For this example we want to create the same three drawer unit that we created with the classic cabinet. Create three boxes.
- Type in # # 150 (6in).
- This is code. The # means use the remainder. So typing in two # and the specific dimension means that we want to use the specific dimension at the top (because it is the last number) and two equal remaining divisions for the rest of the unit.

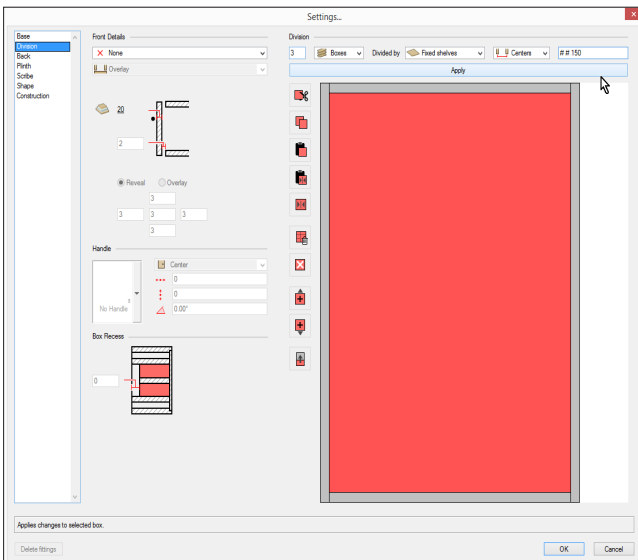

- Click on the **Apply** button.
- When you first apply the boxes, the default option is to have shelves between each box.

- Go to the pop-up menu and choose **None**.

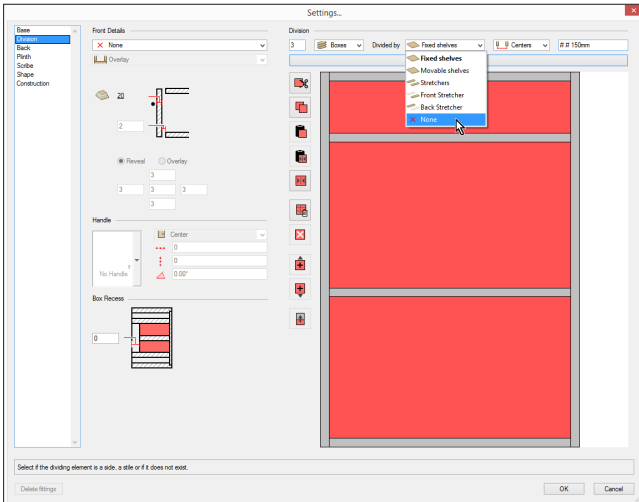

- Click on the **Apply** button once more.

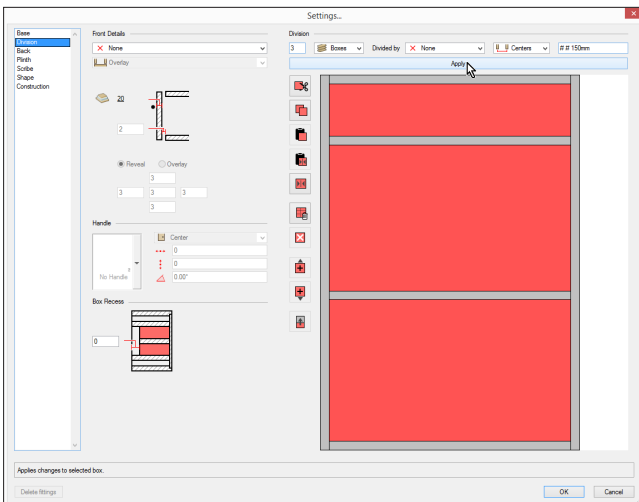

- The shelves will be replaced.
- Click once in the top box.
- The box will highlight.

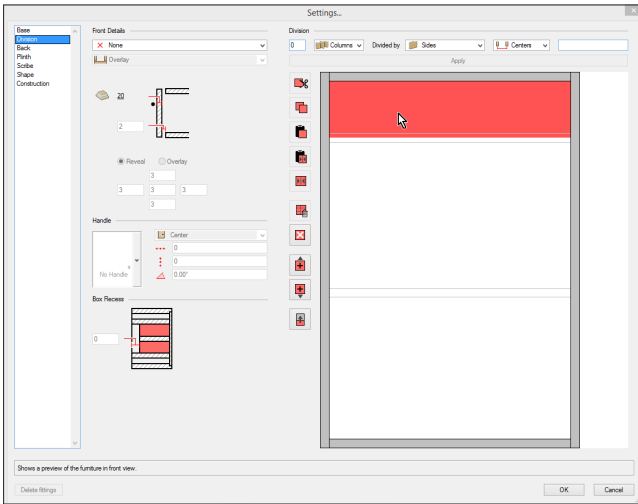

- Under the heading **Front Details**, there is a pop-up menu to choose drawers or doors.
- Choose **Drawer**.

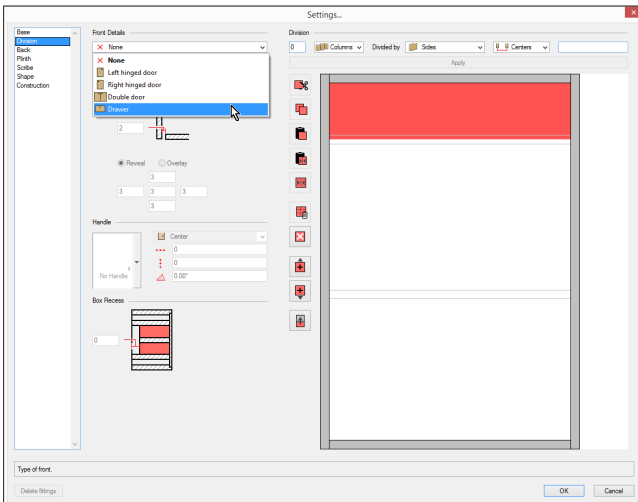

- After choosing the drawer option, click on the icon to choose the handle.
- You can choose from handlers that are in your current file or you can choose from the default set of handles that comes with InteriorCAD.

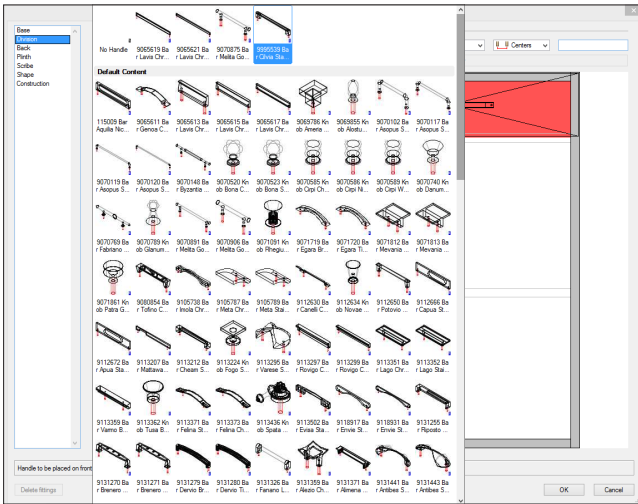

- Unlike the classic cabinet, the drawer handle position is controlled by the savings on this dialog box. You can choose the location of the handle from the pop-up menu next to the drawer handle icon, you can choose the rotation and you can input an offset dimension for the handle.

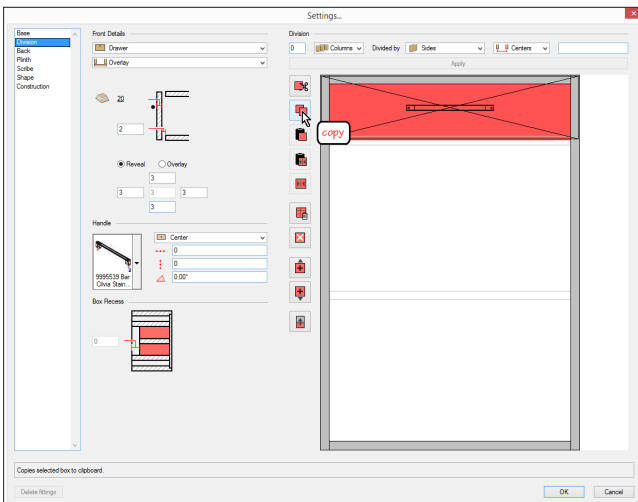

- When you have finished your settings for this drawer, you can click on the copy icon to copy the settings of the drawer.
- Copying the savings will make it quick to create another area that has a matching drawer.
- Click once in the next box position down (the middle second).
- Click once on the **Paste** button.

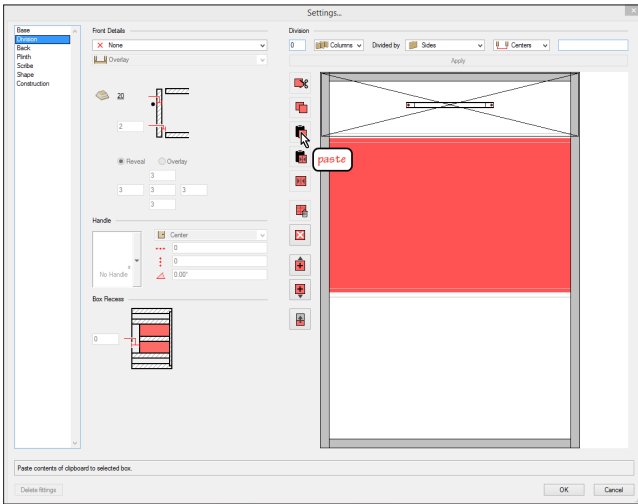

- This will paste the settings from the first drawer on the second.
- Click once in the next box down (the bottom drawer).

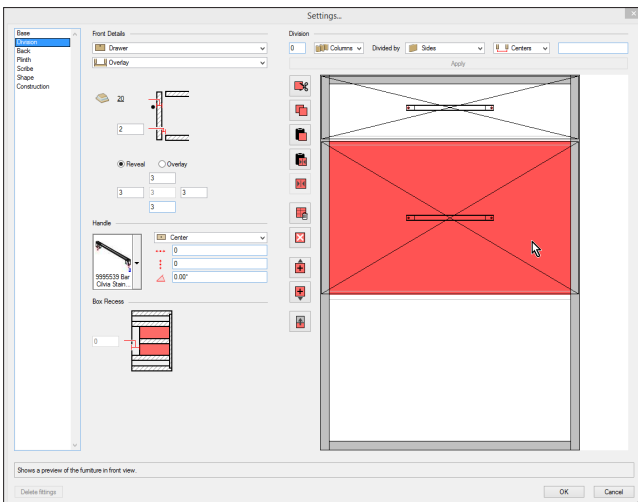

- Click once more on the **Paste** button.

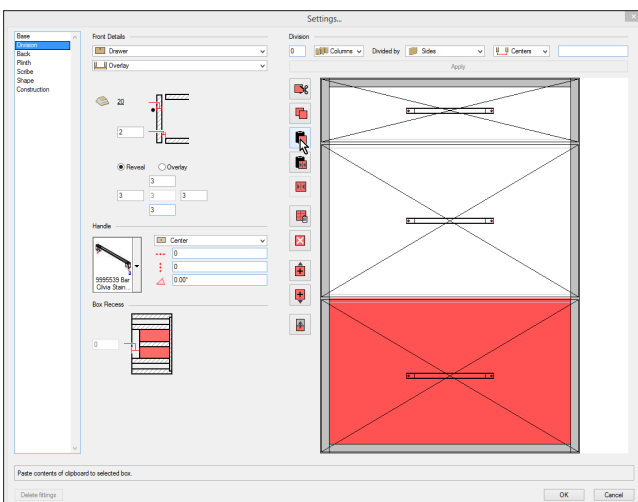

- That has created the front design for the cabinet.
- On the left side of the dialog box click on the **Back** option.
- This is where you choose the options for the back construction. You can adjust the back thickness, location, and construction.
- Change the settings to suit your construction.

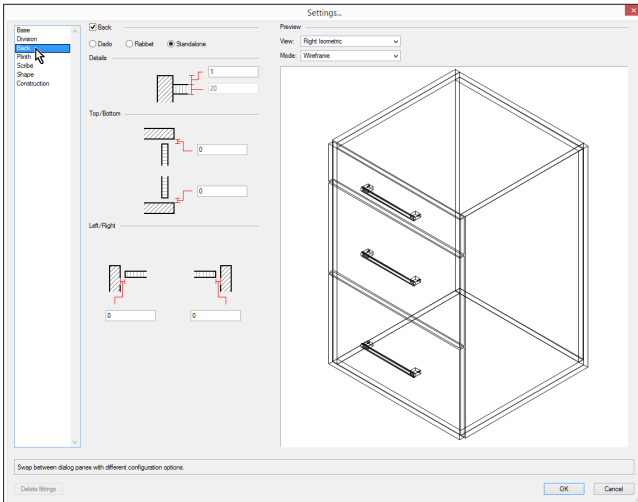

- On the left side of the dialog box click once on the **Plinth** option. This is where you choose kick what toe space construction.

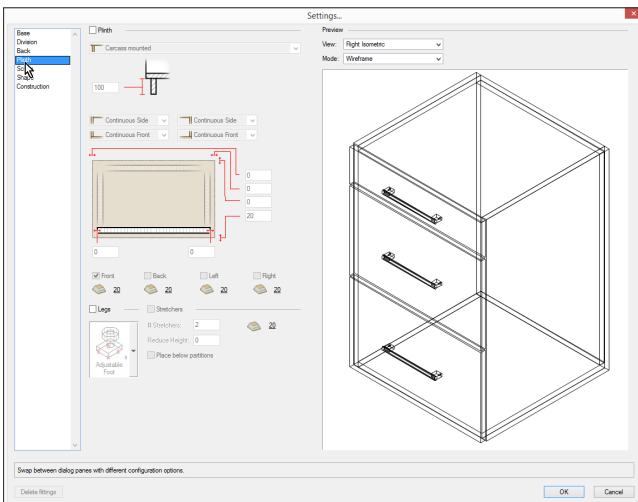

- To activate the Plinth option, click on the tick box at the top left of the dialog box.
- There is a click-able picture in the middle of the dialog box. This box allows you to click on parts of the plan to turn on or turn off the plinth. In my example I turned off all of the areas of the plinth except for the front.
- You can choose to have legs to support your cabinet.
- Click on the tick box next to the legs option. This will activate the legs

for your cabinet.

- Click on the symbol browser to locate the required legs.
- When you assign a plinth to your cabinet The overall height of the cabinet does not change. the height of your plinth is subtracted from the carcass of the cabinet.

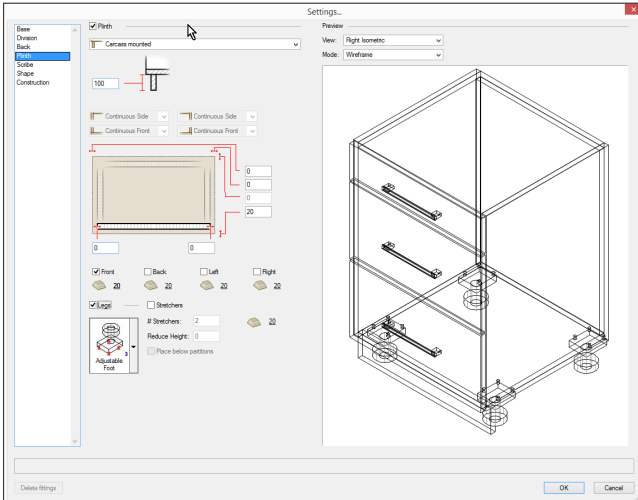

- Click on the **OK** button to return back to the drawing.

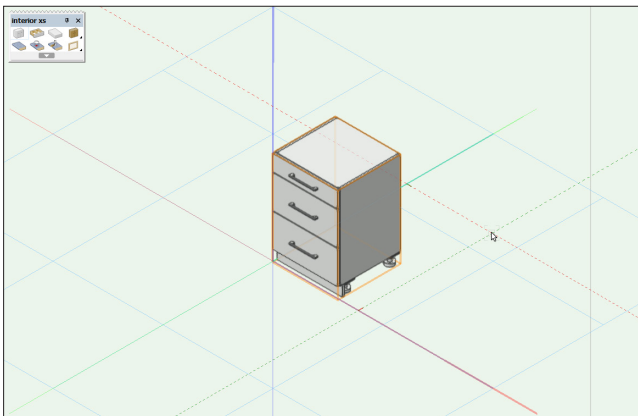

- Another productive technique is saving this unit as a symbol.
- Double click on a cabinet.
- Click on the **Save As Symbol...** button.

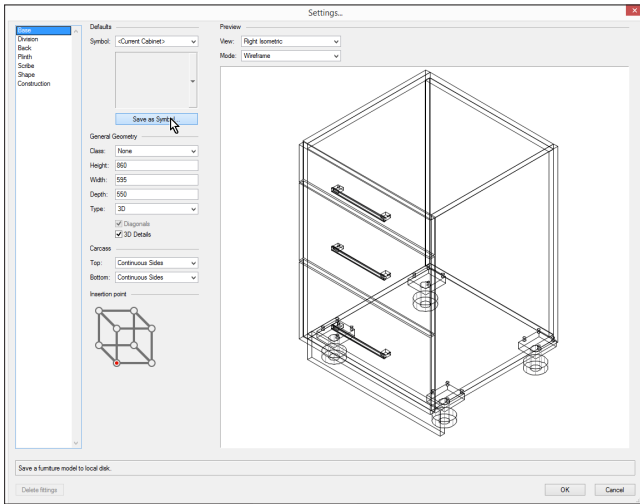

- Name the symbol.
- Click on the **OK** button.

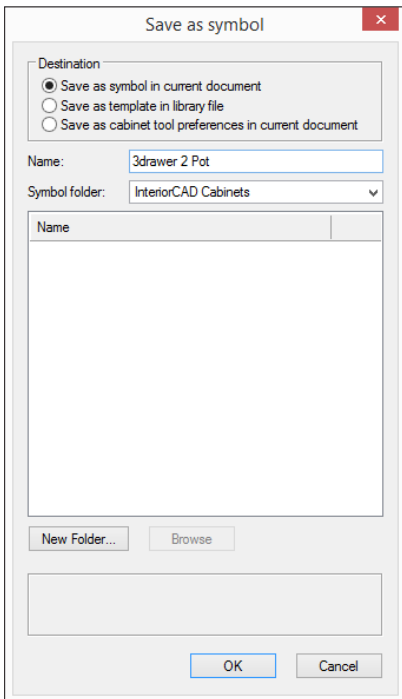

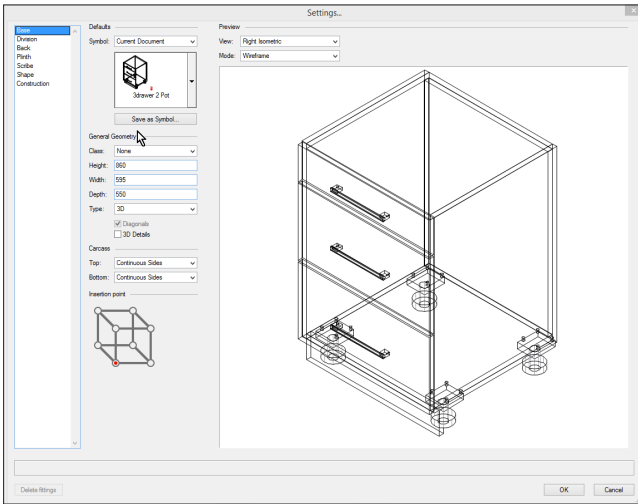

- The symbol appears in the Resource Manager. In this example I have saved my cabinets into a symbol folder to make them easier to find.

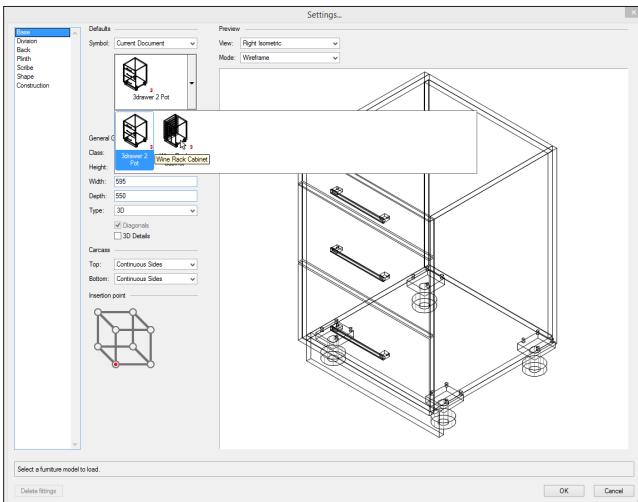

- Choose the required symbol.

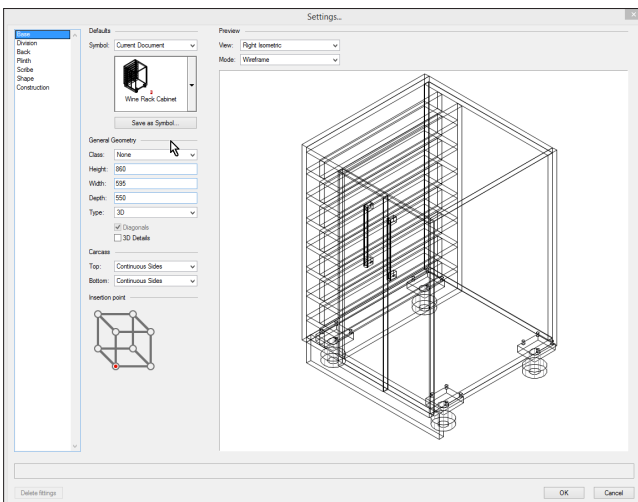

- Click on the **OK** button to return to the drawing. The selected cabinet will be updated.

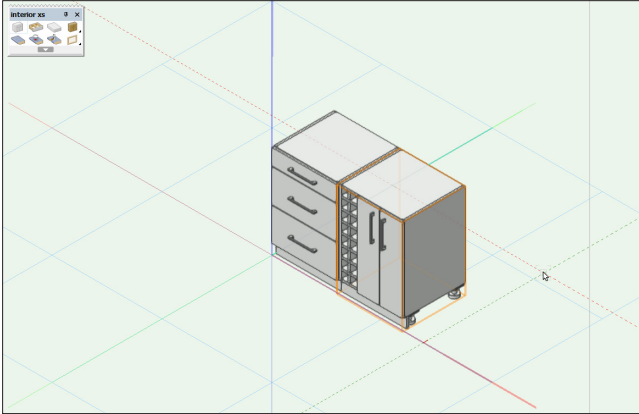

- Create a copy of your first unit. Later on we can convert these units into symbols, but for now we need to keep copies of the work we do.
- Double-click on the interior CAD cabinet to open the **Settings...** dialog box.

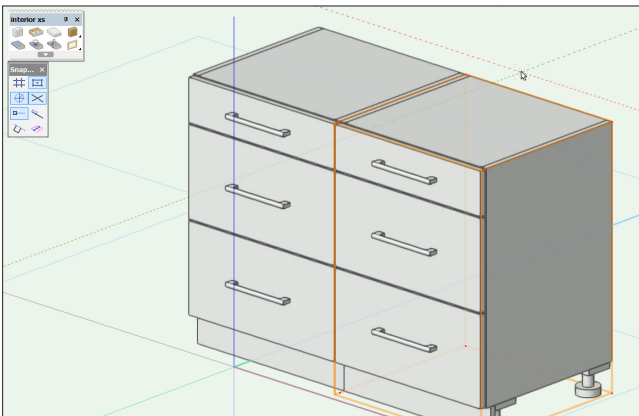

- Click on the Division tab.

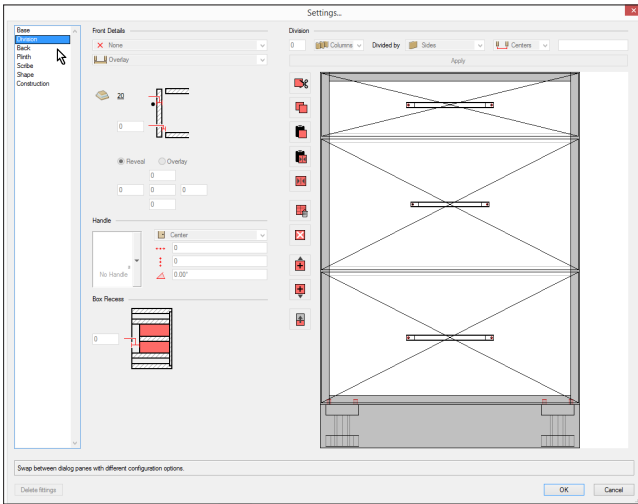

- Click once on one of the drawers.

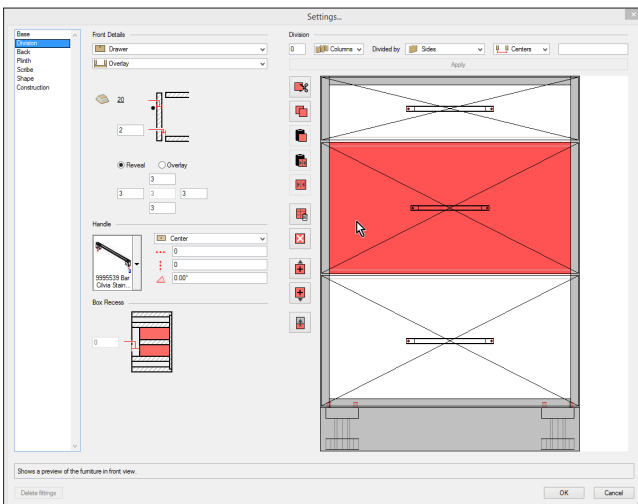

- Click on the up button to move up to the higher part of the front design.

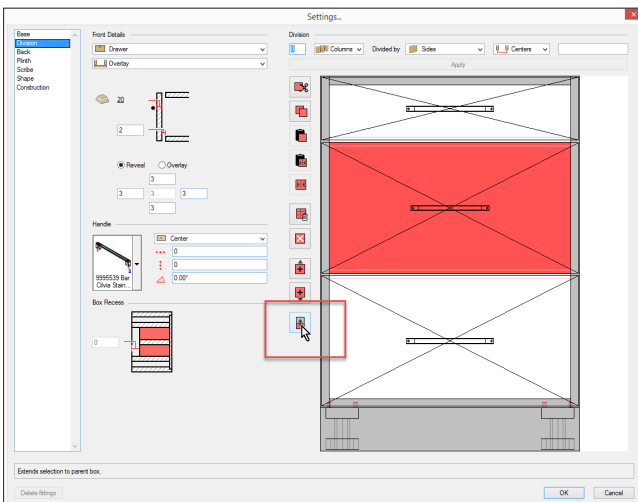

- If you need to, click once again so that the entire front design is

highlighted in red.

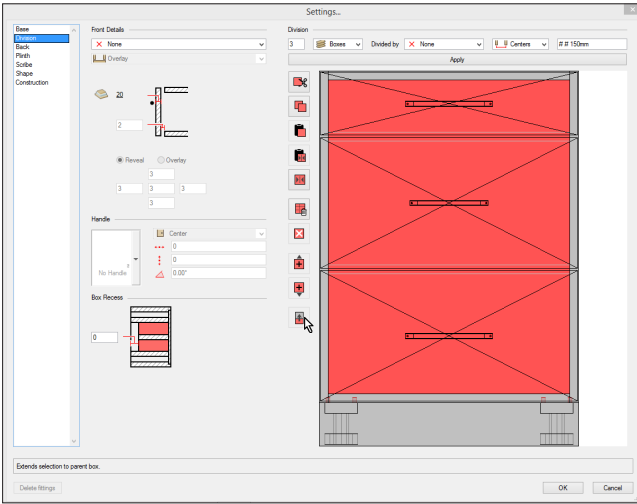

- Click once on the **Cut** button.

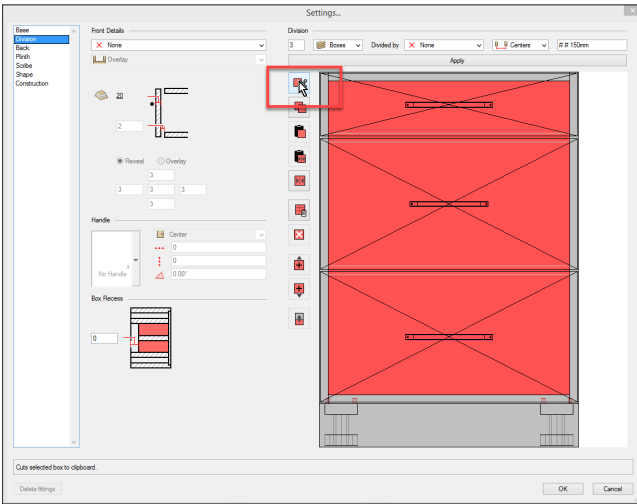

- Click once to remove all of the door and drawers.

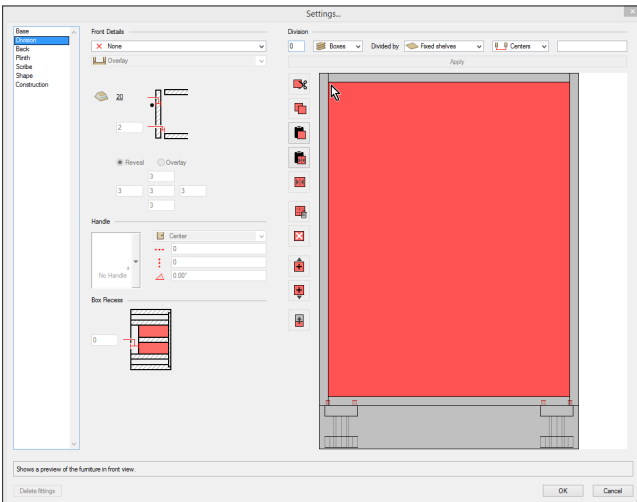

- Now we can add the divisions to create the horizontal area for the top drawer and another area below for the doors. Create two boxes.
- The size of the boxes should be # **150**. This will create a drawer at the top with a specific size (**150mm, 6"**) and the area below will be whatever is left over for the doors.
- On the left side of this dialog box is an area (**Front Design**) to choose the type of material between the divisions.
- Click on this pop-up menu and choose **None**.
- Click once on the **Apply** button.

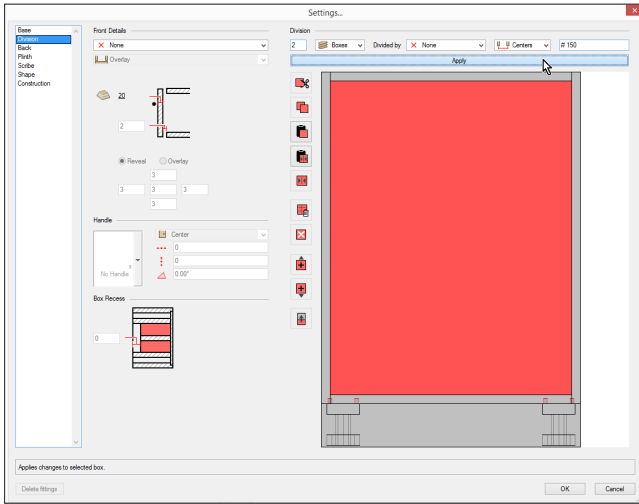

- In this image you can see that the material between the top and bottom divisions is just too thin lines. This means that there is no shelf, no stretches, nothing between these two areas. If you wanted stretches between these two areas (which would be useful for the doors to close against) then you can choose to have a front stretcher between these two divisions rather than nothing.

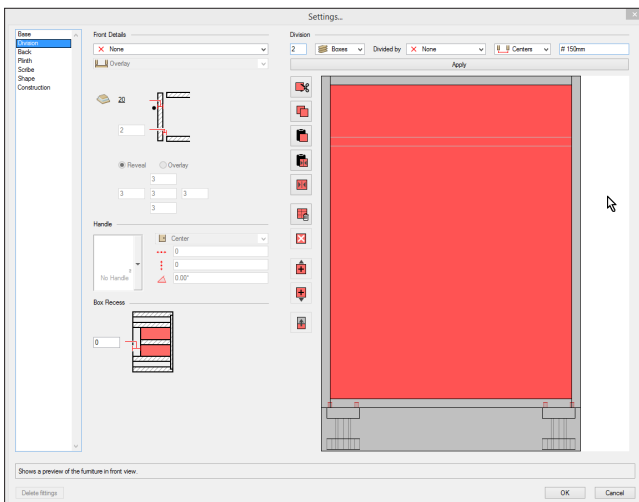

- Click once on the top division and create a drawer. We have previously created drawers so I will not go through all of the details.

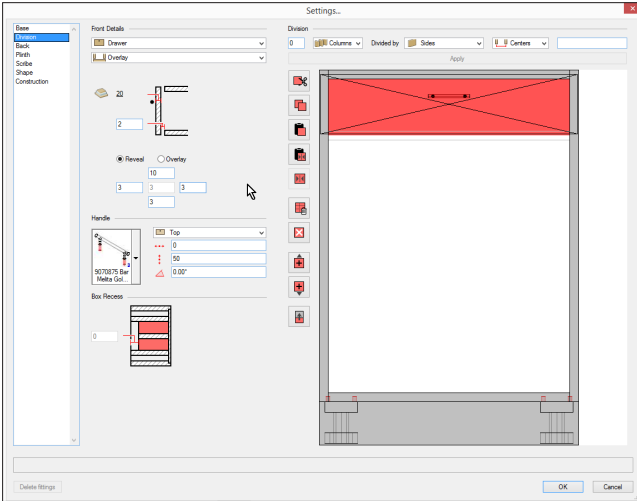

- Click once in the bottom division.

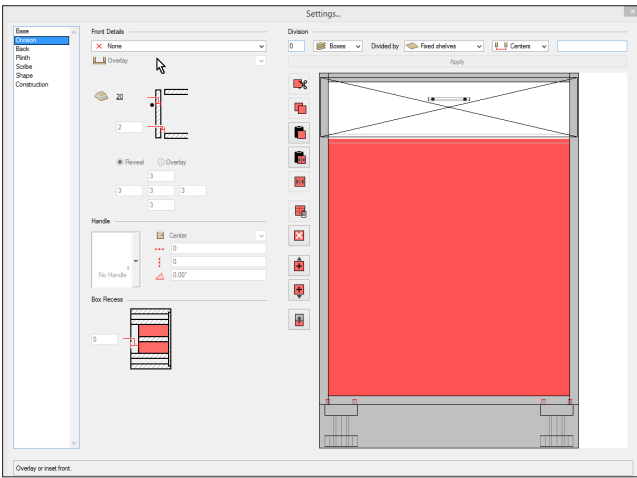

- From the Front Design pop-up menu choose Double Doors.

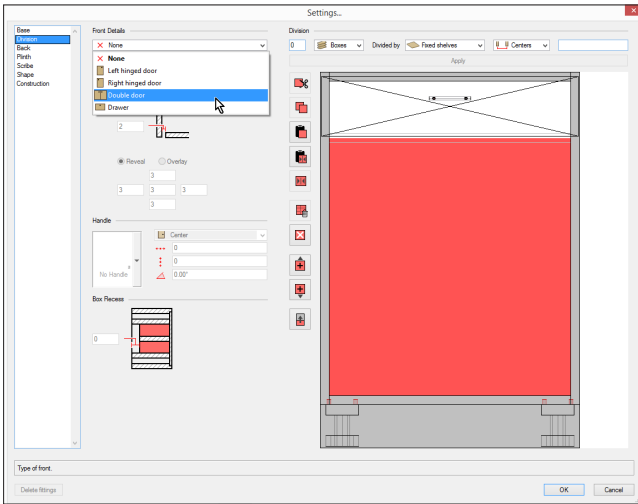

- Add door handles to the doors.

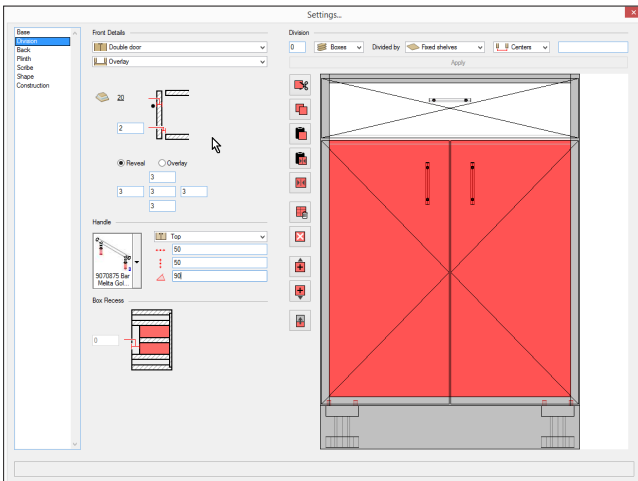

- Click on the **OK** button to return to the drawing.

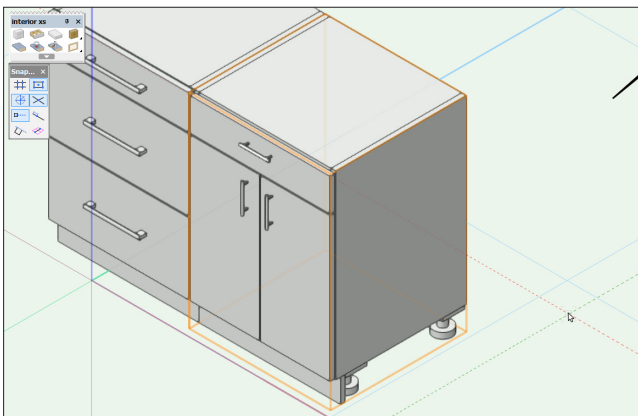

- Once you have the object in your drawing, you can use the Object Info palette to change the width of the unit. Because we have chosen double doors, Vectorworks will update these doors if we change the unit width.

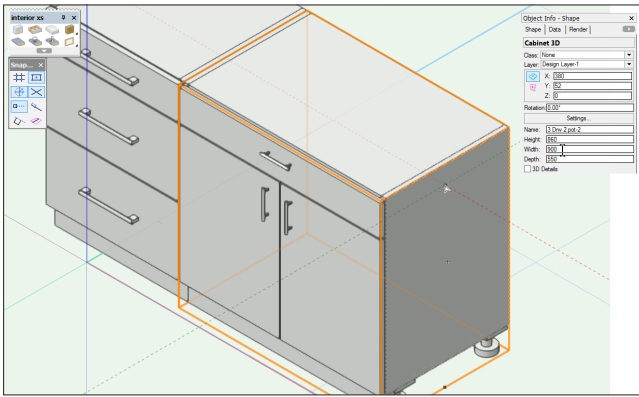

Wine Rack

- Create a copy of your unit.

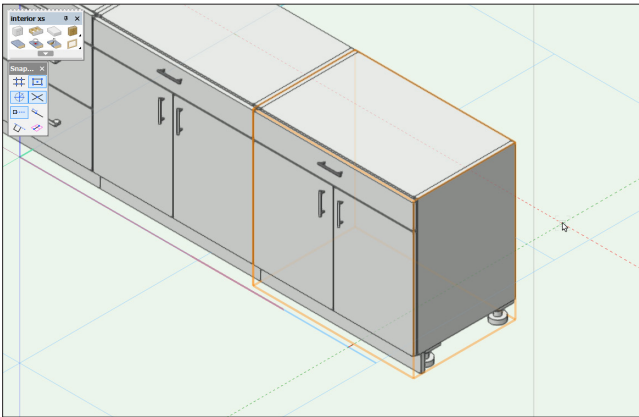

- Double-click on the interiorCAD cabinet to open the **Settings...** dialog box.
- Click on the **Division** tab.
- Remove all the drawers and doors.

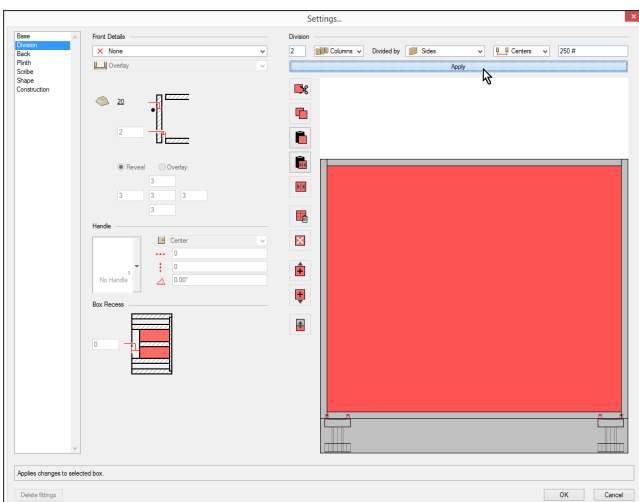

- Create **two** columns.
- The size of the columns should be **250 # (10" #)**.
- Go to the B pop-up menu.
- Click on this pop-up menu and choose **Side**.
- Click once on the **Apply** button.

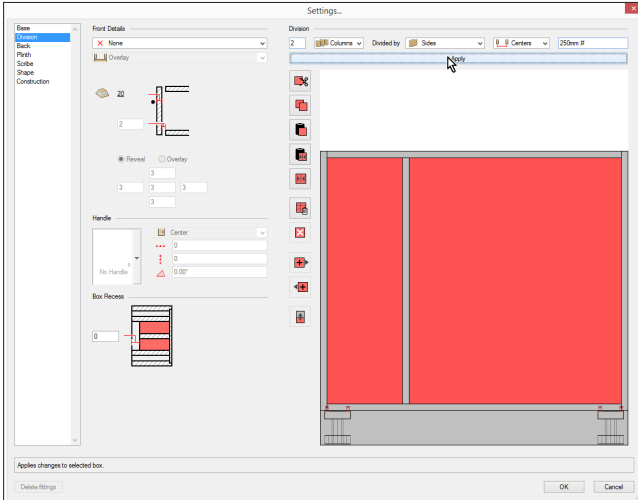

- Click once on the left-hand column, the area for the wine rack.
- Create **six** boxes with fixed shelves between them.

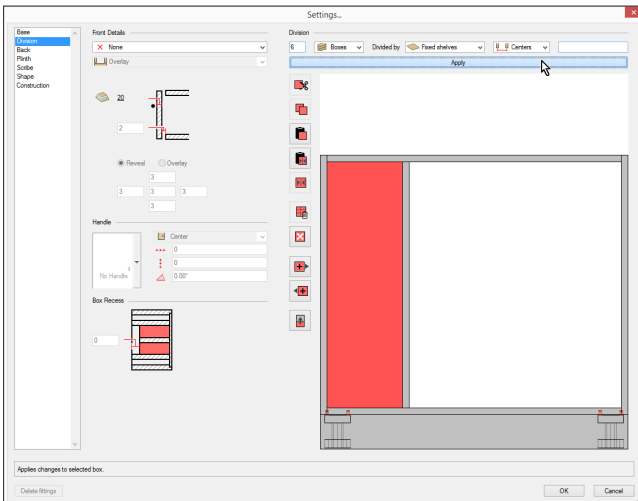

- Click on the **Apply** button.
- Click once on the top box.
- Divide this into **two** columns with a fixed shelf between them.

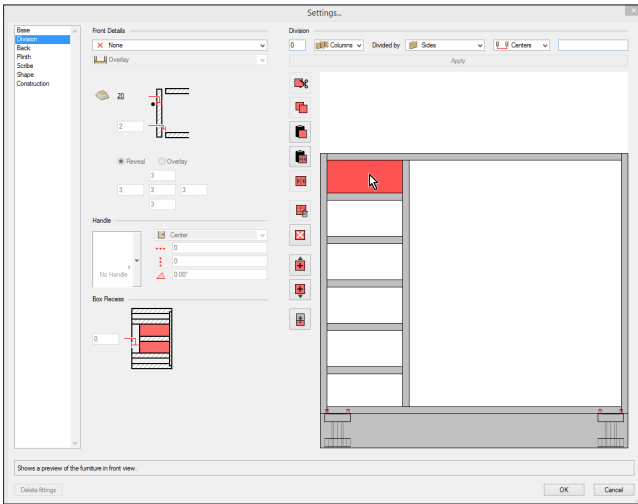

- Use the up button to move up one level so that both columns are selected.

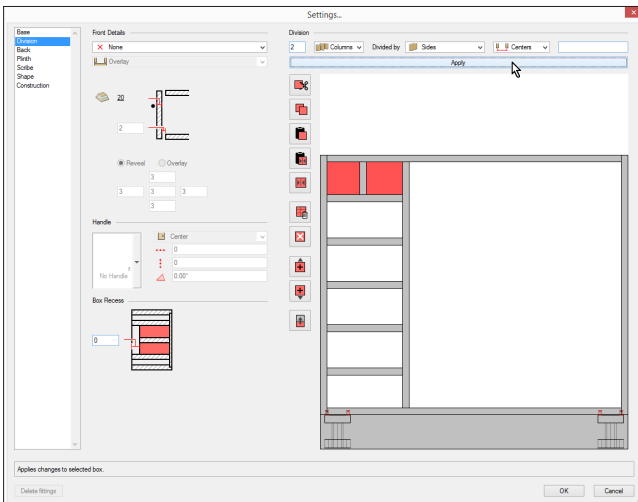

- Click on the **Copy** icon to copy this construction.

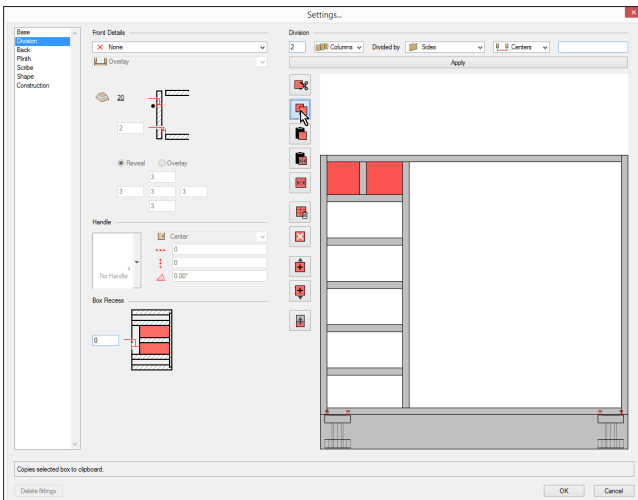

- Click once in the next box down.
- Click on the **Paste** icon to place the construction from the box above.

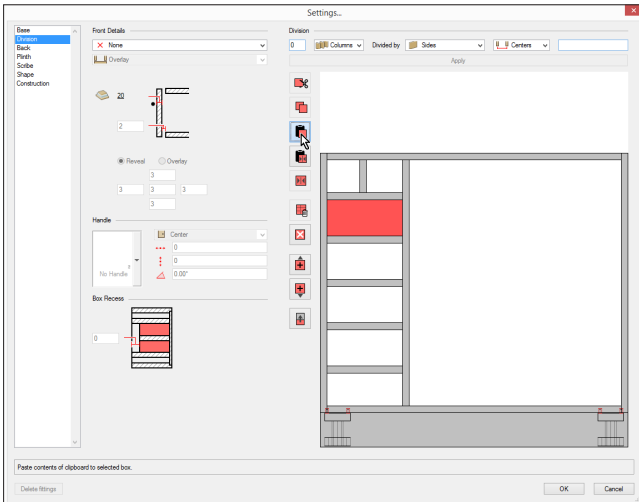

- Move to each box and paste the construction so that all of the wine rack is created.

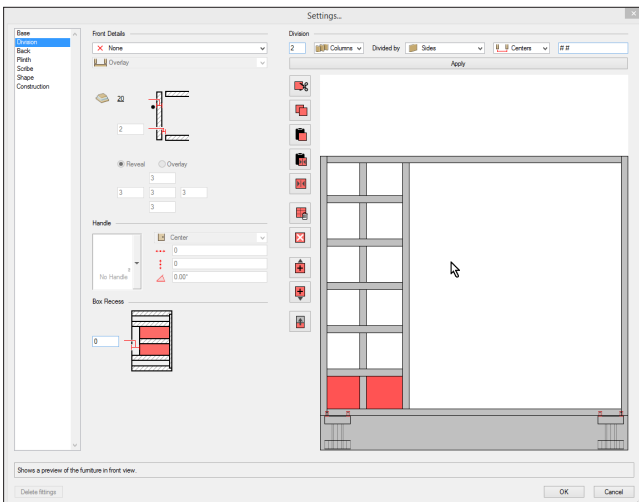

- Click once in the right hand division.
- From the **Front Design** pop-up menu choose Double Doors.
- Add door handles to the doors

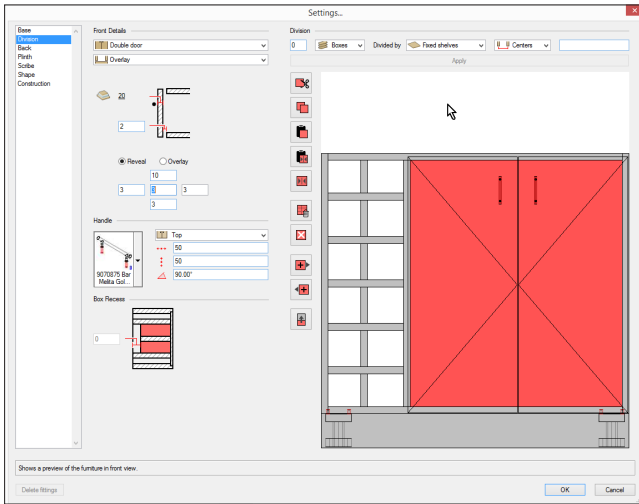

- Click on the **OK** button to return to the drawing

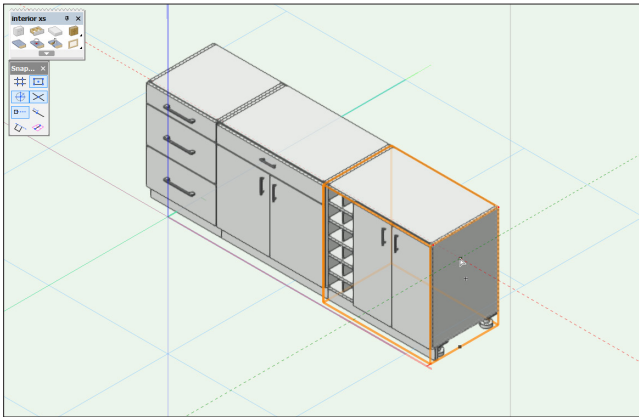

Intermediate Topics

These are topics for intermediate users. I think that if you are learning interiorcad, the beginner topics are enough, but if you want to go further, then these topics should allow you to use interiorcad more fully.

The first topic is to assign materials and textures to the unit. The second topic is to cover some techniques to create more detailed units.

Materials

When you create a unit, you can choose the detailed construction of the unit. For example, you can choose the board construction, the covering to the board, the finish to the board, and any edging on the board.

- For this example I will be using the Custom 3D cabinet. Although the Classic cabinet has a different dialog, the system is similar.
- Double click on a unit.

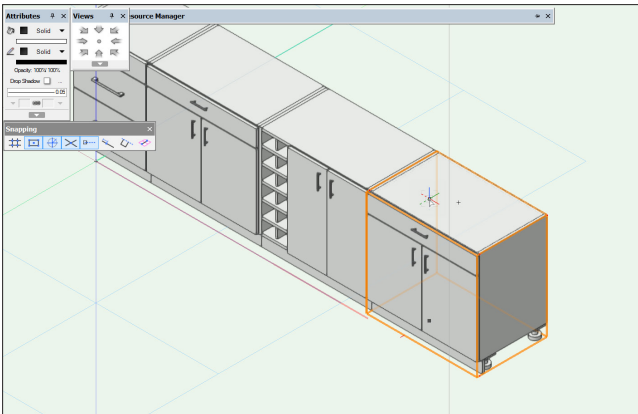

- This opens the Settings... dialog.
- On the left side, click on the **Construction** tab.
- Each part of the cabinet has a option to control the construction.
- Choose the first part of the cabinet. In this cabinet this it the **Cabinet Shelf/Stretche**r. If your cabinet does not have any shelves, you might have a different part.
- After selecting the part, click on the search button for the **Material**.

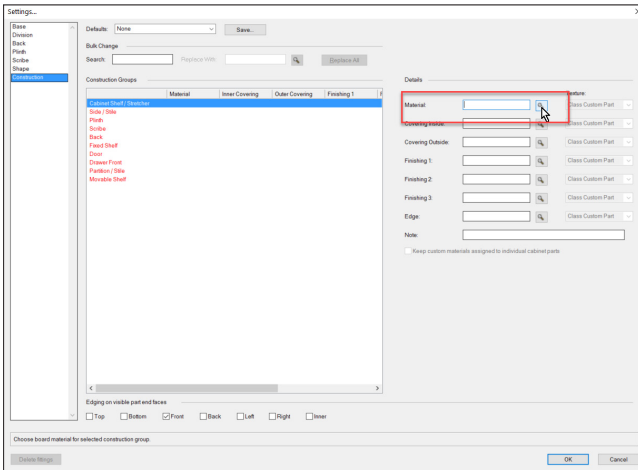

- This opens the dialog box to choose the material.

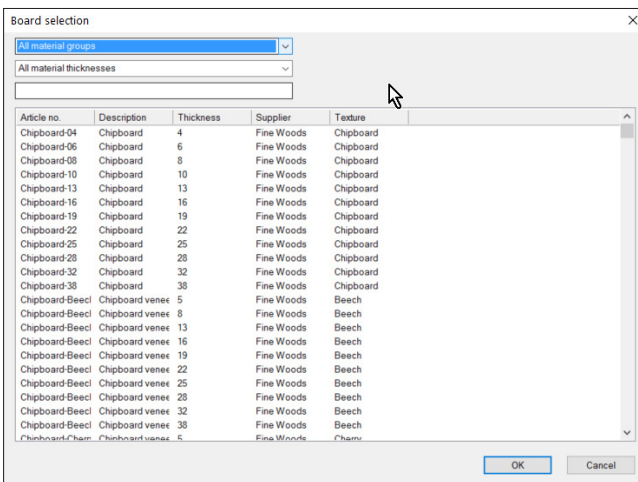

- There are hundreds of boards to choose from.
- The boards have been grouped together, in Material Groups. Material Groups make to easier to filter the boards, to find the one you require.
- In this case, I have chosen laminated walnut.

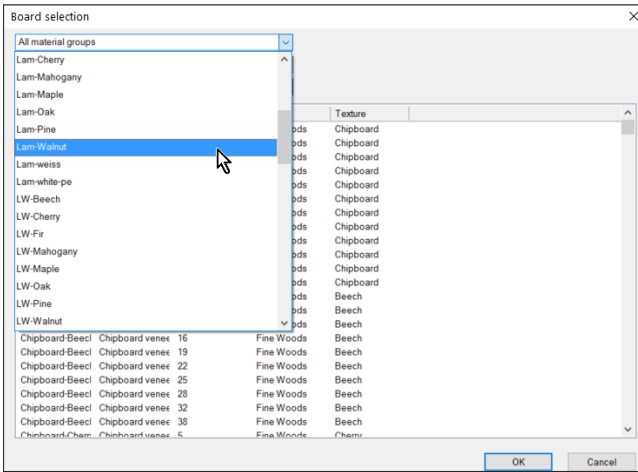

- Choosing the material group will filter the long list of materials, to make it easier to find boards.
- Click on the required board.
- Click on the **OK** button.

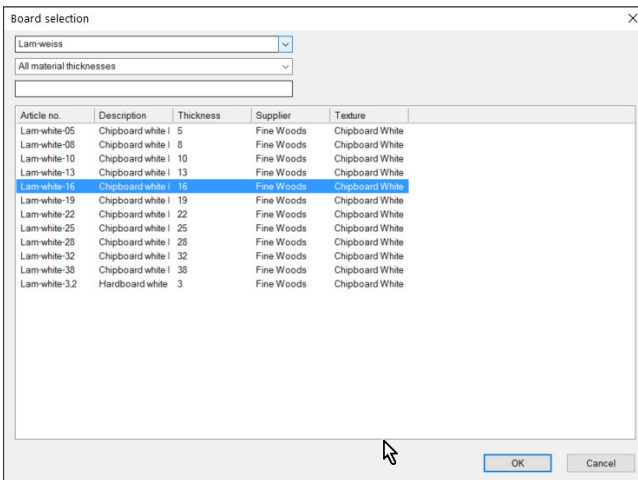

- After choosing the board, you can use the same technique for the covering and finishing.
- This image shows choosing the edging for the board.

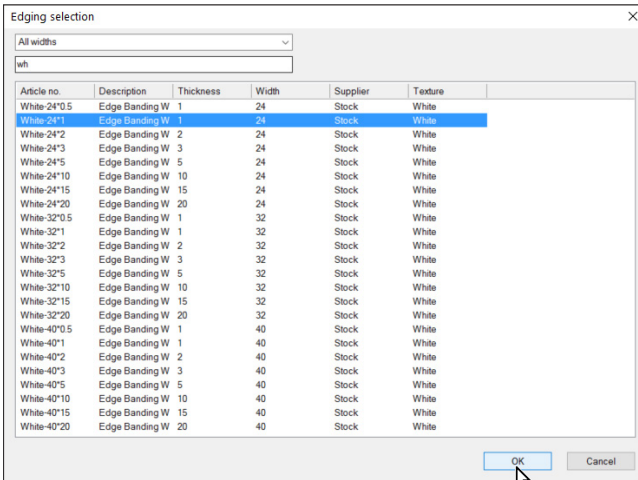

- You can choose which edges of the board need edging, by using the options at the bottom of the settings dialog.
- When you choose the material it also selects the texture. The selected texture can be changed by clicking on the texture and choosing a different one.

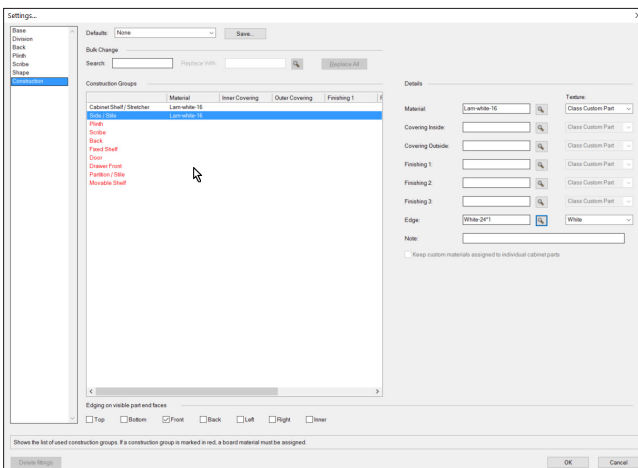

- Check all the options you have selected for the first part.

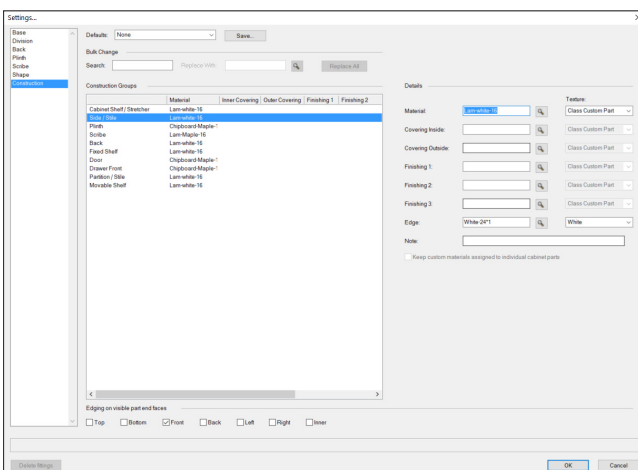

- Click on the next part and set all the options for the material.

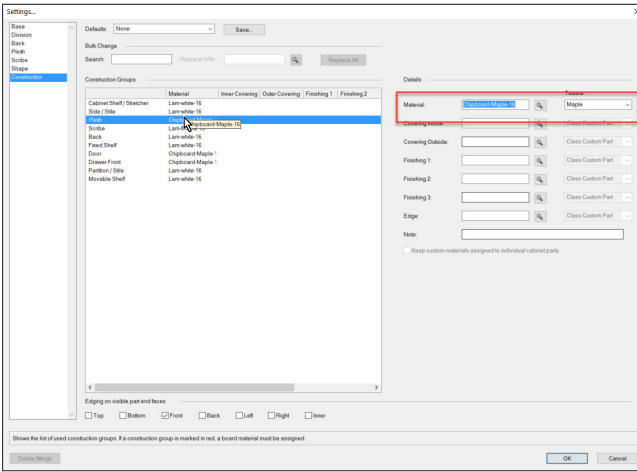

- Set the materials for all the parts.
- When you return to the rendered view, you should see the textures on the cabinet.

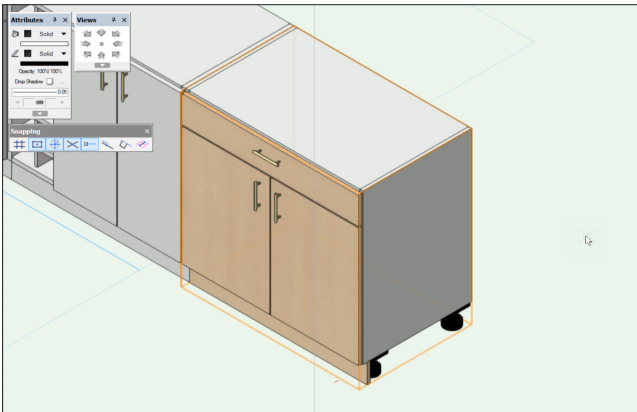

Controlling The Carcass

It is quite common to want to control the carcass in more detail. For example, you might want to change the top of the cabinet so that instead of having a solid top it has room for a kitchen sink. In this case you would want to change the solid top to stretches.

In this example I will be using the custom cabinet, not the classic cabinet.

- Double-click on the cabinet to open the **Settings...** dialog box.
- On the left side click on the tab to control Divisions.

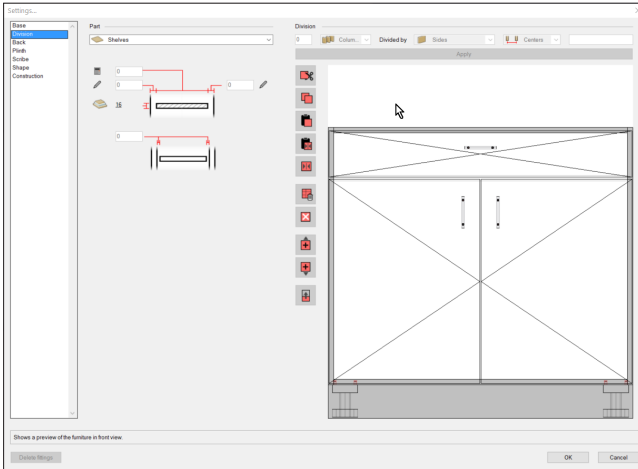

- Click on the top of the carcass.
- The top shelf will highlight.

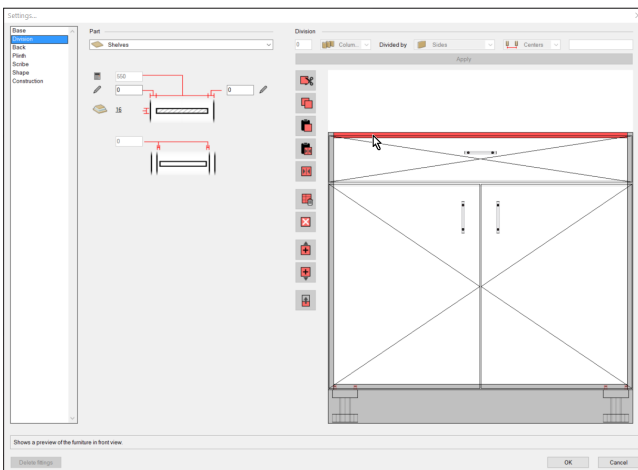

- Go to the **Front Design** pop-up menu and choose **Stretches**. This will replace the solid top with two rails.

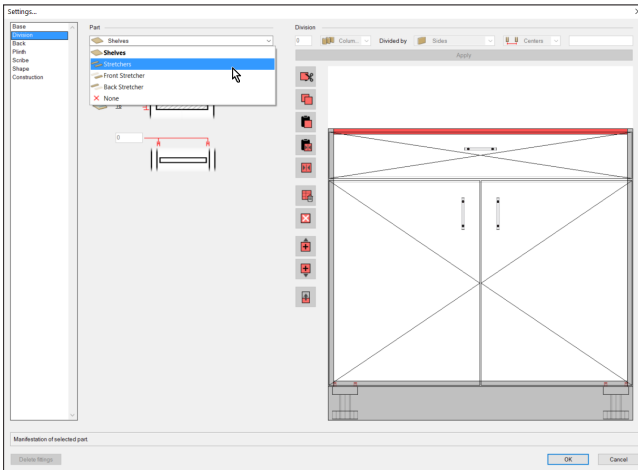

- Adjust the settings of the stretches to suit your design.

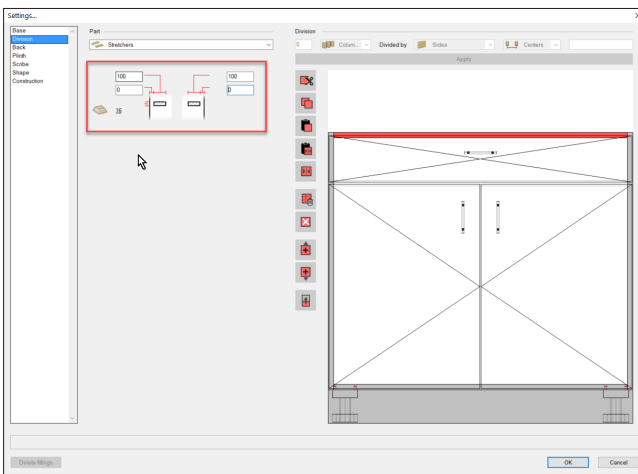

- Click on the **OK** button to return back to the drawing.

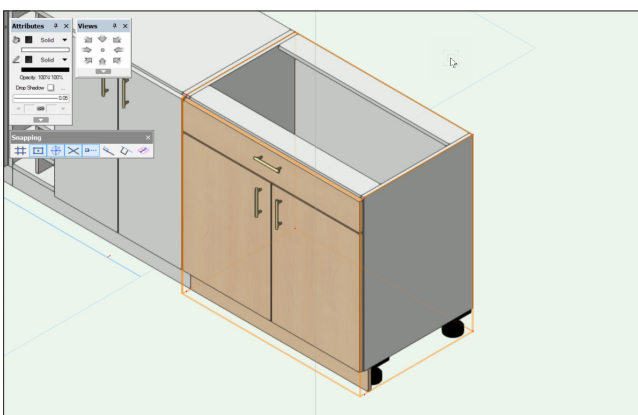

- Another technique that you might want is the ability to turn off a side of the carcass. You might need to do this where you have two cabinets butting into each other.
- Double-click on the cabinetto open the **Settings...** dialog box.

- On the left side click on the tab to control **Divisions**.

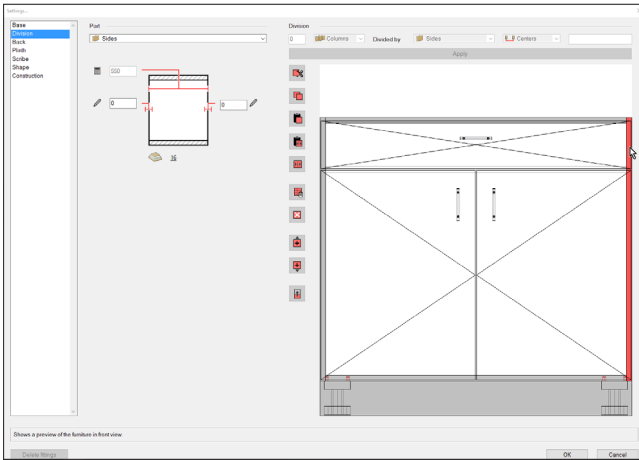

- Click on the side of the carcass.
- The side will highlight.
- Go to the **Front Design** pop-up menu and choose **None**.

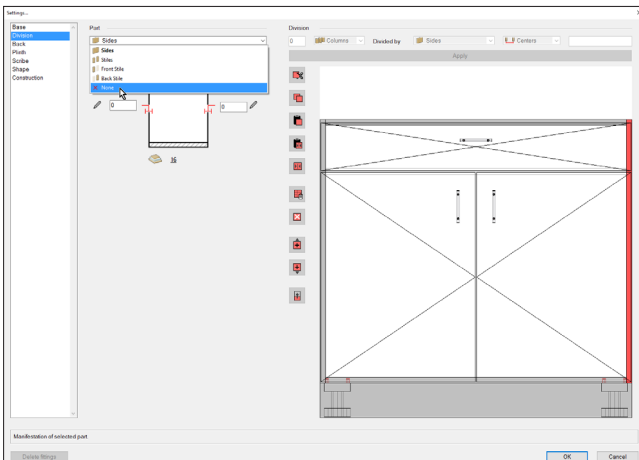

- Click on the **OK** button to return back to the drawing.

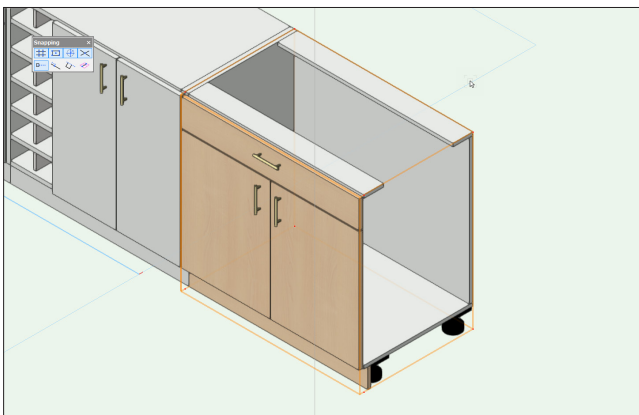

- The last technique that I want to look at is the ability to turn off the back

of the carcass.

- Double-click on the cabinet to open the **Settings...** dialog box.
- On the left side click on the tab to control **Back**.
- Turn off the **Back** option on the back will be removed from the cabinet

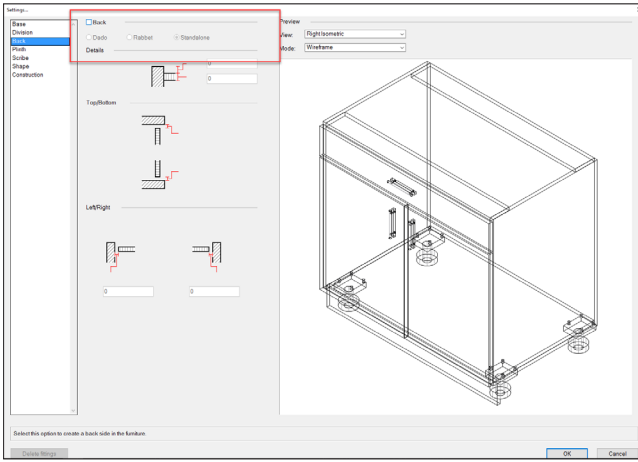

- Click on the **OK** button to return back to the drawing.

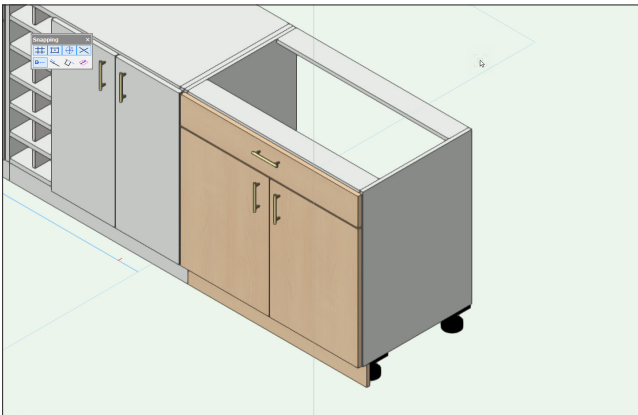

Conclusion

InteriorCAD does not come standard with Vectorworks. This is an additional purchase that you have to make. If you are working with interior design, restaurant design, or you need to make cabinetry for your projects, then this extra cost will soon be outweighed by your ability to quickly create the cabinets you require.

This manual has only touched on some of the basic functions of interior CAD XS. We have not looked at the ability to create framed doors and drawers, and we haven't looked at the ability to create a worktop with a sink.

I believe it's clear that interiorCAD is a very valuable addition to Vectorworks. Because it creates its objects as BIM objects, you can use them to create your drawings in detail.

Thank you

We trust that you have enjoyed working through this manual and that it has been informative and constructive.

For more information, please visit: <http://learn.archoncad.com/>. If you just want someone to help you learn Vectorworks, to carry out some Vectorworks contract work, or you want someone to make Vectorworks easier, contact us, as this is a service that we also offer:

jon@archoncad.com

Thank you again,
Jonathan Pickup
May 2017

