

# Suction cup OB65x170P Polyurethane 60, brass 3/8" NPSF female, OB65X170P.5E.N40W

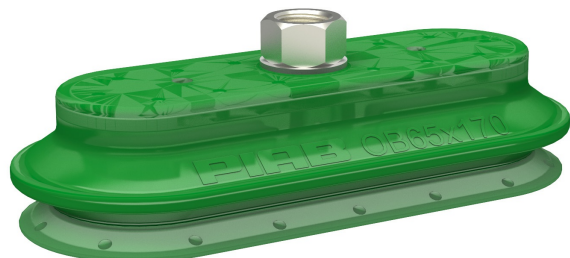

- Suitable for level adjustment. Can handle objects with height differences and varying shapes, for example embossed or corrugated plates.
- Lifting movement to separate small and thin objects.
- Dual hardness allowing strength and stability in conjunction with softness and flexibility.
- DURAFLEX® material features the elasticity of rubber in combination with the wear resistance of polyurethane.
- The DURAFLEX® material is mark-free.

## General

Curve radius	1.50 in
Movement, vertical max.	0.63 in
Application	Mark Free
Material	Polyurethane (PU60)
Suction cup model	OB
Suction cup shape	Oval Bellows
Volume	10.7 in <sup>3</sup>
Weight	8.50 oz

## Fitting

Fitting size	1/8"
Fitting style	Female
Fitting type	NPSF-thread
Fitting option	None

## Dimension

Height	2.15 in
Outer diameter	6.97 in
Width	2.99 in

## Performance — lifting forces

		
6 -inHg	29.2 lbf	38.2 lbf
18 -inHg	69.7 lbf	98.9 lbf
27 -inHg	120 lbf	135 lbf

## Material

	Polyurethane (PU60)
Color	Green transparent
Hardness	60 Shore A
Temperature	50 – 122 °F

## Material resistance

	Polyurethane (PU60)
Alcohol	N/A
Concentrated acids	+
Ethanol	+
Hydrolysis	+
Methanol	-
Oil	+++
Oxidation	-
Gasoline	+
Wear resistance	+++
Weather and ozone	+++

## Dimensional drawings

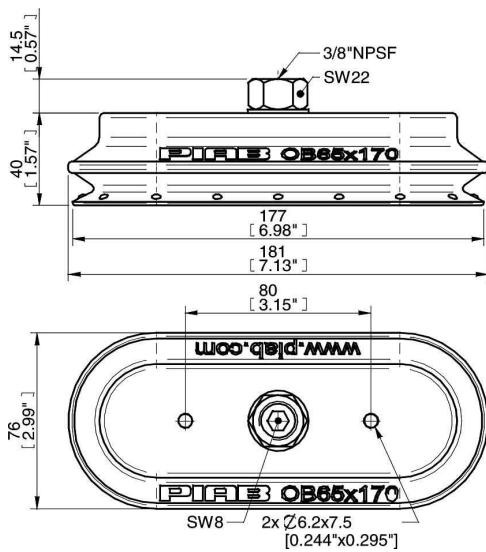

## Spare parts

	Part no.
Suction cup OB65x170P Polyurethane 60 with collar for Vacuum Gripper System (VGS)	OB65X170P.5E

## Accessories

	Part no.
Suction cup OB65x170P Polyurethane 30/60 with collar for Vacuum Gripper System (VGS)	OB65X170P.5K
Thread insert G3/8" male, with O-ring and mesh filter for Vacuum Gripper System (VGS)	01.07.148