

Suction cup F20 Silicone, M5 female, 0101270

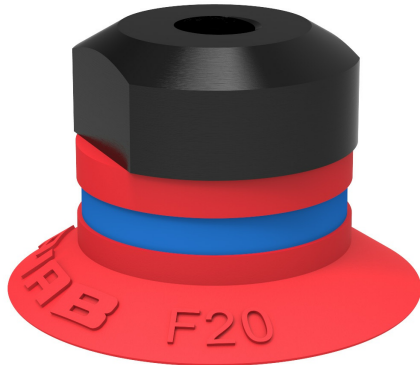

- Suitable for flat objects.
- Good stability and little inherent movement.
- Recommended when the lifting force is parallel to the surface of the object.
- Cleats prevent thin, sensitive objects from being deformed and gives extra friction when the lifting force is parallel.



General

Curve radius	18 mm
Movement, vertical max.	1.5 mm
Application	Dry sheet metal
Material	Silicone (SIL)
Suction cup model	F
Suction cup shape	Flat
Volume	1 cm ³
Weight	1.2 g

Fitting

Fitting size	None
Fitting style	Female
Fitting type	M-thread
Fitting option	None

Dimension

Height	14 mm
Outer diameter	22 mm

Performance — lifting forces

		
20 -kPa	6 N	5 N
60 -kPa	14.5 N	8 N
90 -kPa	19 N	8.5 N

Material

	Silicone (SIL)
Colour	Red
Hardness	50 °Shore A
Temperature	-40 – 200 °C

Material resistance

	Silicone (SIL)
Alcohol	++
Concentrated acids	-
Ethanol	N/A
Hydrolysis	+
Methanol	N/A
Oil	-
Oxidation	+++
Petrol	-
Wear resistance	++
Weather and ozone	+++

Dimensional drawings

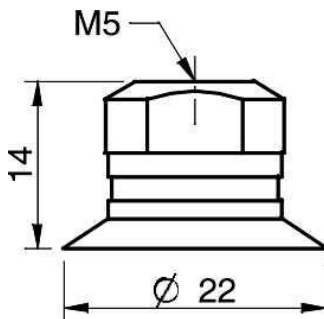

Spare parts

	Item no.
Suction cup F20 Silicone	0101130
Fitting M5 female	3250003

Accessories

	Item no.
Suction cup F20 Chloroprene	0101129
Fitting M5 female, with dual flow control valve	3251001
Fitting G1/8" male/M5 female, with mesh filter	0101152
Fitting G1/8" male/M5 female, with dual flow control valve	3251004
Fitting G1/8" male/M5 female, PA	3150196
Fitting G1/8" male, with mesh filter and dual flow control valve	3251002
Fitting G1/8" male, with mesh filter	3250085
Fitting 5xM5 female, with dual flow control valve	3251005
Fitting 5xM5 female	0100260
Fitting 1/8" NPT male, with dual flow control valve	3251003
Fitting G1/8" male/M5 female	3250004
Fitting 1/8" NPT male, with mesh filter	3250088