

# WRC Wide Rail Ball Type Linear Guide Series

## WRC Product Feature

The **cpc** WRC Linear Guide Series has a wide rail which can absorb larger torque from Mr direction. With the O-type arrangement for the four row ball circulation design, the contact angle between the rail and ball is 45 degrees which can realize the 4 directional load effects. In addition, the runner block for the same size uses larger and more balls, so will outperform competitor's models by 10% to 30% regarding load capabilities. The products have characteristics of high load, high moment, and high rigidity.



## Low-noise, high-quality, and high-speed patent ball chain

WRC ball chain patent design provides large contact area between ball which can provide better maintenance of oil film; achieve low noise; balls can operate with higher speed; extend the product service life.

Low noise ball chain

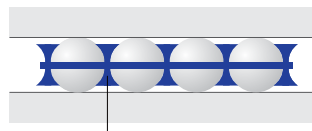

The contact point is between balls and ball chain, so the surface pressure is low.

Traditional Ball type linear guide

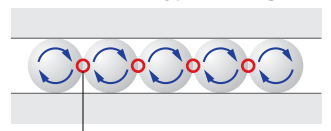

The Ball type linear guide's contact point is only between balls, thus the surface pressure is high.

## Reinforcement plate patent design

Using 2 stainless steel reinforcement plates, the L type design can fasten the screws onto the top and bottom of the runner block, reinforcing the rigidity of the end caps and cladding.

The WRC type uses the stainless steel reinforcement plates to strengthen the bottom latches, while increasing X-axis direction force capacity, and increasing operation speed.

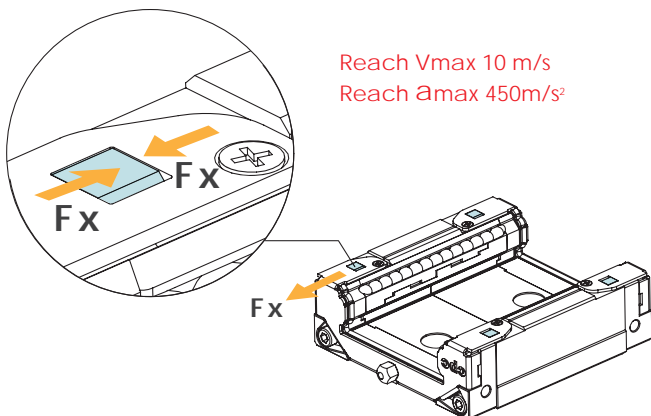

## Lubrication Design Inner oil storage and oil supply system design

Inner PU Lubrication Storage Pad design does not increase the length of the runner block. Besides, it contact directly with all balls; ensure long term lubrication effects; conform to environmental protection needs; low maintenance costs; moreover, it present excellent performance when used in short stroke.



Upper Lubrication Storage Pad

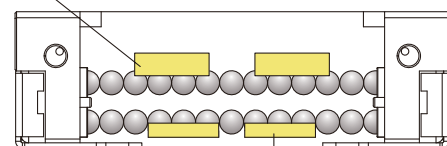

Bottom Lubrication Storage Pad

# WRC Wide Rail Ball Type Linear Guide Series

## Dustproof design

### Stainless Steel Reinforcement Plate

With clearance between rail profile for less than 0.3mm, the plate can scrape large items such as iron filings to protect the end seals.

### Inner Seals

The inner seals can protect foreign objects from sliding into the rails while maintaining low friction. It can also allow the lubrication oil to be maintained inside the runner block and prolong the re-lubrication interval.

### Bottom Seals

The bottom seals can prevent foreign objects from entering the bottom and prevent lubrication from leaking out. With full sealing design, it reduces the amount of oil usage, prolong the re-lubrication interval, and prolong the service life.

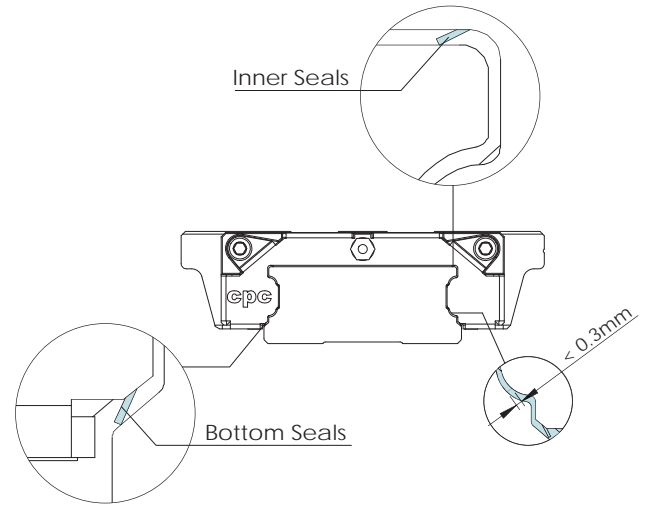

## Dimension Table

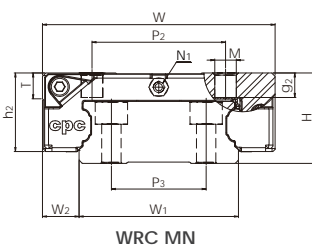

WRC MN

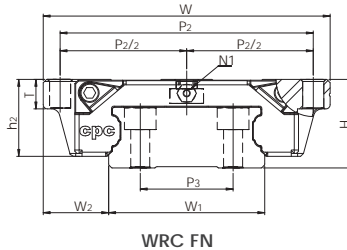

WRC FN

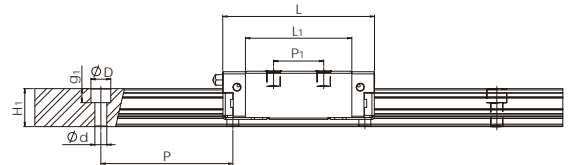

Model Code	Mounting Dimensions		Rail Dimensions(mm)						Block Dimensions(mm)								Load Capacities (kN)		Static Moment (Nm)			
	H	W <sub>2</sub>	W <sub>1</sub>	H <sub>1</sub>	P	P <sub>3</sub>	D <sub>x</sub> d <sub>x</sub> g <sub>1</sub>	W	L	L <sub>1</sub>	h <sub>2</sub>	P <sub>1</sub>	P <sub>2</sub>	M <sub>x</sub> g <sub>2</sub>	M <sub>1</sub>	T	N <sub>1</sub>	C	C <sub>0</sub>	M <sub>r0</sub>	M <sub>p0</sub>	M <sub>y0</sub>
WRC21/15MN	21	8.5	37	14.4	50	22	7.5x4.5x5.3	54	57.5	40.3	18.3	19	31	M5x5	-	6	M3	9.9	17.5	315	105	105
WRC21/15FN	21	15.5	37	14.4	50	22	7.5x4.5x5.3	68	57.5	40.3	18.3	29	60	M5x7	M4	7	M3	9.9	17.5	315	105	105
WRC27/20MN	27	10	42	18	60	24	7.5x4.5x5.3	62	69	52	24	32	46	M6x7	-	10	M3	17.1	30.0	605	230	230
WRC27/20FN	27	19	42	18	60	24	7.5x4.5x5.3	80	69	52	24	40	70	M6x11	M5	11	M3	17.1	30.0	605	230	230
WRC35/25MN	35	15.5	69	21	80	40	11x7x9	100	105	86	29	50	76	M8x8	-	14	M6	30.7	57.7	1960	710	710
WRC35/25FN	35	25.5	69	21	80	40	11x7x9	120	105	86	29	60	107	M8x14	M6	14	M6	30.7	57.7	1960	710	710

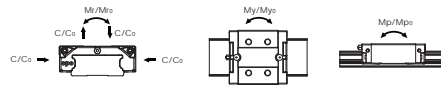

The above rating load capacities and static moment are calculated according to ISO14728 standard. The rating life for basic dynamic load rating is defined as the total 100km travel distance that 90% of a group of identical linear guides can be operated individually under the same conditions free from any material damage caused by rolling fatigue. When the standard of 50km travel distance is applied, the above basic dynamic load rating C of ISO 14728 should be multiplied by 1.26 for conversion.

## Ordering information Model code

WRC	21/15	M	N	B	2	Z	C	V1	P	-1480L	-20	-20	II	/J
Customization code														
Number of rails on the same moving axis														
End hole pitch (mm)														
Starting hole pitch (mm)														
Rail length (mm)														
Accuracy grade : UP, SP, P, H, N														
Preload class : VC, V0, V1, V2														
C: with ball chain														
Z: with lubrication storage pad														
Block quantity														
Seal type : B: Low friction S: Standard														
Block length : N: standard														
Block width : M: standard F: flanged														
Block type : 21/15, 27/20, 35/25														
Product type : WRC: Wide Rail Ball Type Linear Guide Series														

\* Please note that the specifications are subject to change without notice due to product improvements.