



4560 BUCKLEY ROAD • LIVERPOOL, NY USA 13088
315.437.1611 • FAX 315.437.1903 • EMAIL: FLEXHOSE@FLEXHOSE.

Installation and Maintenance Instructions for Flexible Rubber Connectors and Expansion Joints

INSTALLATION

- 1) Expansion joint elastomer must be chemically compatible with the media in the piping system. If in doubt about suitability, refer to a Chemical Resistance Data Table (see link at bottom) or contact our office for guidance.
- 2) Check system pressure and temperature and do not exceed recommended performance limits. Operation beyond design limits will result in premature failure.
- 3) Be sure all pipelines are supported so expansion joints do not carry the pipe load.
- 4) Piping system must be adequately anchored to limit the pipe movements the joint must absorb. If anchoring is not possible, control units must be used so that movements (axial, lateral, and angular) do not exceed maximum published allowable movements. Movement beyond recommended guidelines will result in premature failure.
- 5) The expansion joint should be installed close to a main anchor and should be followed by properly spaced pipe guides to prevent displacement of the line.
- 6) Do not mate butterfly valves or inlet side of check valve.
- 7) Initial pipe misalignment must not exceed 1/8" in any direction.
- 8) If the expansion joint must be installed with an initial misalignment, compression, or extension, then the maximum allowable movements are reduced by the amount of the initial deflection.
- 9) Install joints with neutral face to face dimension as shown on the submittal drawing.
- 10) Clean all foreign matter from faces of mating metal flanges. The rubber must mate with a smooth, clean surface.
- 11) Apply a thin coat of graphite in water or glycerin prior to installation. This will enable easy removal at a future time. When removal is necessary, small wooden wedges may be used to break the seal between metal and rubber without damage to the joint.

- 12) Insert bolts from the arch side of the expansion joint so that bolts do not interfere with the arch during compression. Tighten the bolts by alternating around the flange until all bolts are tightened evenly. Initial bolt torque should be as follows:

Bolt Torque Recommendations	
Sphere Size	Bolt Torque
1 1/2" to 2 1/2"	45 ft./lbs.
3" to 10"	60 ft./lbs.
12" to 20"	80 ft./lbs.

- 13) When installing the NNDFU, the union nut closest to the sphere body should be held stationary while the large center nut of the union is tightened securely. This will ensure that adequate pressure will be maintained between the sealing face of the metal union and the rubber bead of the sphere body. Continue to check and periodically re-tighten the union connections as necessary.
- 14) Do not cover expansion joints with insulation as this makes it difficult to detect leaks and could restrict movement of the joint. Insulation on joints on the hot side is not recommended. The use of insulation on the rubber body will not allow heat to vent to atmosphere. If heat is not allowed to dissipate the body will dry out quickly and greatly reduce the life expectancy.
- 15) Welding should not be performed in the vicinity of a rubber joint. If it is imperative to weld nearby, cover the joint with a welding cloth and pack the pipe in dry ice to prevent heat transfer. (Do not allow temperature of the rubber to reach 275 degrees F.)
- 16) To help protect the outer cover from sunlight aging (or ozone attack), neoprene joints should be painted with a Hypalon paint once a year.

MAINTENANCE

- 1) Check all connection tightness one week after placing joint in service, as the rubber will take a slight set. Continue to check periodically thereafter. (See Install 12)
- 2) Check bolts whenever changing over from one medium to another or when there are repeated temperature swings in the line.
- 3) Periodically check the outside cover of the joint for damage. Replace any joint with cracks or gouges.
- 4) During maintenance shutdowns, remove joints and inspect the interior for deterioration. Replace any joint which shows signs of wear.
- 5) For critical lines, it is recommended that a spare expansion joint be kept on hand to be used in the event of failure. This will minimize equipment downtime while a replacement joint is ordered.

DuPont has a comprehensive elastomer chemical resistant chart at: https://mscrm-dupont.secure.force.com/CRG_Home

www.flexhose.com • 1.877.TRI FLEX

A world of difference in critical piping connections since 1968.TM

Installation Instructions

Control Unit Assembly

(Excerpt from Technical Handbook of Rubber Expansion Joint Fluid Sealing Association)

A control unit is a system of two or more control rod (tie rod) assemblies placed across an expansion joint from flange to flange to minimize possible damage to the expansion joint caused by excessive motion of the pipeline. This excessive motion could be caused by the failure of an anchor or some other piece of equipment in the pipeline. Figure 1 shows the proper assembly of an expansion joint with control unit details. The control rod assemblies are set at the maximum allowable expansion and/or contraction of the joint and will absorb the static pressure thrust developed at the expansion joint. When used in this manner, they are an additional safety factor, minimizing possible failure of the expansion joint and possible damage to the equipment. Control units will adequately protect the joints but the user should be sure that pipe flange strength is sufficient to withstand total force that will be encountered. The term "Control Unit" is synonymous with the term "Tie Rod" as defined by the standards of the Expansion Joint Manufacturer's Association (EJMA).

Control units may be required to compensate for both extension and compression movements.

Extension: Control units must be used when it is not feasible in a given structure to provide adequate anchors in the proper locations. In such cases, the static pressure thrust of the system will cause the expansion joint to extend to the limit set by the control rods which will then preclude the possibility of further motion that would tend to lengthen the joint. Despite the limiting action that control rods have on the joint, they must be used when proper anchoring cannot be provided. It cannot be emphasized too strongly that rubber expansion joints, by the virtue of their function are not designed to take end thrusts and, in all cases where such are likely to occur, proper anchoring is essential. If this fact is ignored, premature failure of the expansion joint is a foregone conclusion.

Compression: Pipe sleeves can be installed over the control rods. The purpose of these sleeves is to prevent excessive compression in the expansion joint. The length of this pipe sleeve should be such that the expansion joint cannot be compressed beyond the maximum allowable compression figure stated by the manufacturer. See Table 1.

INSTALLATION

- 1) Install the expansion joint at its normal face to face dimension between the pipe flanges.
- 2) During Step 1, install the control rod plates (gusset plates) at equal distances around the outer circumference of the pipe flange. Bolt each gusset plate behind the pipe flange at each location.
- 3) Place a steel washer on each control rod bolt and insert through the third hole in each plate. Steel washers are to be positioned at each outer surface of the control rod plate. See Figure 1.
- 4) Position the nut so there is a gap equal to the joint's maximum extension between the nut and the steel washer. Lock this nut in place by tack welding the nut to the rod before installation. If two jam nuts are furnished with the control rod assembly, tighten the jam nuts together to prevent loosening.
- 5) If excessive compression exists, optional compression sleeves, sized to allow the expansion joint to compress only to its normal limit, should be slipped over each rod prior to installation.
- 6) Rated compression and extension for Style NNS and NND spherical connectors are shown in Table 1. These two dimensions are critical in setting the nuts and sizing compression spacers.

Figure 1

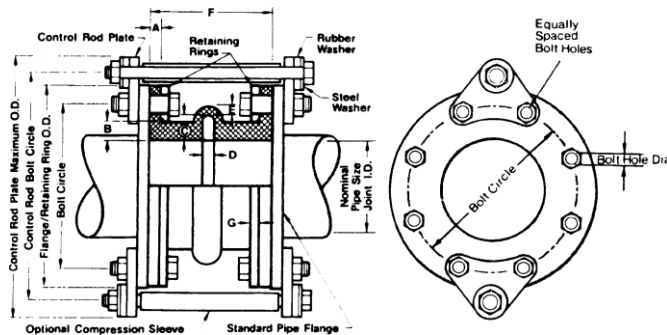

Table 1
Movement Capabilities

NNS Single-Sphere Connector			NND Double -Sphere Connector		
Joint Size ID x F/F	Maximum Compression	Maximum Extension	Joint Size ID x F/F	Maximum Compression	Maximum Extension
1.5"x6"	1/2"	3/8"			
2"x6"	1/2"	3/8"	2"x7"	1"	3/4"
2.5"x6"	1/2"	3/8"	2.5"x7"	1"	3/4"
3"x6"	1/2"	3/8"	3"x7"	1"	3/4"
4"x6"	5/8"	3/8"	4"x9"	1.25"	1"
5"x6"	5/8"	3/8"	5"x9"	1.25"	1"
6"x6"	5/8"	3/8"	6"x9"	1.25"	1"
8"x6"	5/8"	3/8"	8"x13"	1.5"	1"
10"x8"	3/4"	1/2"	10"x13"	1.5"	1"
12"x8"	3/4"	1/2"	12"x13"	1.5"	1"
14"x8"	3/4"	1/2"	14"x13.75"	1.5"	1 3/16"
16"x8"	3/4"	1/2"			
18"x8"	3/4"	1/2"			
20"x8"	3/4"	1/2"			

Table 2: Bolt Torque Recommendations

Sphere Size	Bolt Torque
1 1/2" to 2 1/2"	45 ft./lbs.
3" to 10"	60 ft./lbs.
12" to 20"	80 ft./lbs.



Installation Instructions

StopLink™ Cable Control Unit Assembly

Without proper anchoring a flexible expansion joint may very well over-extend from pressure thrust damaging the integrity of the device. To minimize possible damage from over-extension caused by pressure thrust, excessive movement of the piping system or from anchor failure a control device is recommended. Traditionally a control unit is a system of two or more control rod (tie rod) assemblies placed across an expansion joint from flange to flange to minimize this possible damage. The disadvantage to the use of standard control rods is it is necessary to set the jam nuts properly in the field (at installation) to insure movement is limited to the joints capability. With the use of the StopLink; cable length is factory pre-set, designed for the maximum rated sphere extension, so there are no jam nuts to set in the field. StopLinks are designed to adequately protect the joints but the user should be sure that pipe flange strength is sufficient to withstand total force that will be encountered.

Expansion Joint Extension: is encountered when a piping system contracts (cools down). It will also occur through pressure thrust when it is not feasible in a given structure to provide adequate anchors in the proper locations. The static pressure thrust of a piping system will cause the expansion joint to extend to the limit set by the control cables and retard further motion that would over-extend the joint (beyond its design capability). It cannot be stated too strongly that rubber expansion joints, by the nature of their design are not designed to take end thrusts, proper anchoring is essential. If proper anchoring and/or protection from over-extension is ignored, premature failure of the expansion joint will ultimately occur.

Expansion Joint Compression: occurs in the typical application when a piping system expands (heats up). Confirm that the amount of pipe expansion anticipated is within the compression capability of the flexible expansion joint. If protection is required from possible over-compression a standard control rod assembly should be utilized (with optional pipe stops) to help protect the expansion joint from over compression. It is not recommended that pipe stops be used with the StopLink Cable Control assembly.

INSTALLATION

- 1) Typically an expansion joint is installed at its neutral face to face dimension between the pipe flanges.
- 2) The flanges on the sphere rotate (prior to tightening) to allow bolt hole alignment
- 3) Verify the number of StopLink sets required to handle the system pressure as indicated in the table below
- 4) During Step 1, install the StopLink plates (gusset plates) at equal distances around the outer circumference of the mating pipe flange. They should be installed so the cable is in a straight line across the expansion joint. This will reduce stress on the cable and the cable ends. Bolt each gusset plate behind the mating pipe flange at each location
- 5) The StopLink cable length is factory pre-set, designed for the maximum rated sphere extension, so it will not be taunt when the joint is at its neutral face-to-face dimension.
- 6) Follow the installation instructions that accompany the sphere for additional information regarding tightening and inspection.

**Table
StopLink Pressure Capabilities**

NND or NNS nominal Sphere Size	Maximum Working / Test Pressure (PSI)	Number of sets required (gussets and cables per set)	Maximum Working/Test Pressure (PSI)	Number of sets required (gussets and cables per set)
2"	225 / 338	One (4 gussets, 2 cables)		
2-1/2"	225 / 338	One (4 gussets, 2 cables)		
3"	225 / 338	One (4 gussets, 2 cables)		
4"	225 / 338	One (4 gussets, 2 cables)		
5"	225 / 338	One (4 gussets, 2 cables)		
6"	225 / 338	One (4 gussets, 4 cables)		
8"	225 / 338	One (4 gussets, 4 cables)		
10"	175 / 265	One (4 gussets, 4 cables)	225 / 338	Two (8 gussets, 8 cables)
12"	125 / 190	One (4 gussets, 4 cables)	225 / 338	Two (8 gussets, 8 cables)

MAINTENANCE

In a typical application no maintenance is required for the StopLink. During routine inspection of the sphere the StopLink cables should be inspected for any damaged or frayed wires. Also look for any corrosion in the cables and cable end fittings. In the event damage or corrosion is evident the StopLink assembly should be replaced immediately.

www.flexhose.com • 1.877.TRI FLEX

A world of difference in critical piping connections since 1968.TM