



SuperStor Ultra EVO

Stainless Steel Storage Tanks

Installation

Start-Up

Maintenance

Parts

Warranty

For Residential and Commercial Use

SSU EVO CB Models



WARNING

This manual must only be used by a qualified installer / service technician. Read all instructions in this manual before installing. Perform steps in the given order. Failure to do so could result in substantial property damage, severe personal injury, or death.

California Proposition 65 Warning: This product contains chemicals known to the State of California to cause cancer, birth defects, or other reproductive harm.

NOTICE

The manufacturer reserves the right to make product changes or updates without notice and will not be held liable for typographical errors in literature.

The surfaces of these products contacted by potable (consumable) water contain less than 0.25% lead by weight as required by the Safe Drinking Water Act, Section 1417.

NOTE TO CONSUMER: PLEASE KEEP ALL INSTRUCTIONS FOR FUTURE REFERENCE.

SPECIAL ATTENTION BOXES	
The following defined terms are used throughout this manual to bring attention to the presence of hazards of various risk levels or to important product information.	
	DANGER
DANGER indicates an imminently hazardous situation which, if not avoided, will result in serious personal injury or death.	
	WARNING
WARNING indicates a potentially hazardous situation which, if not avoided, could result in personal injury or death.	
	CAUTION
CAUTION indicates a potentially hazardous situation which, if not avoided, may result in moderate or minor personal injury.	
CAUTION	
CAUTION used without the safety alert symbol indicates a potentially hazardous situation which, if not avoided, may result in property damage.	
CAUTION	
CAUTION used without the safety alert symbol indicates a potentially hazardous situation which, if not avoided, may result in property damage.	
NOTICE	
NOTICE is used to address practices not related to personal injury.	

Foreword

This manual is intended to be used in conjunction with other literature provided with the storage tank. This includes all related control information. It is important that this manual, all other documents included with this system, and additional publications be reviewed in their entirety before beginning any work.

Installation should be made in accordance with the regulations of the Authority Having Jurisdiction, local code authorities, and utility companies which pertain to this type of water heating equipment.

Authority Having Jurisdiction (AHJ) – The AHJ may be a federal, state, local government, or individual such as a fire chief, fire marshal, chief of a fire prevention bureau, labor department or health department, building official or electrical inspector, or others having statutory authority. In some circumstances, the property owner or his/her agent assumes the role, and at government installations, the commanding officer or departmental official may be the AHJ.

NOTE: HTP reserves the right to modify product technical specifications and components without prior notice.

For the Installer

This storage tank must be installed by qualified and licensed personnel. The installer should be guided by the instructions furnished with the storage tank, and by local codes and utility company requirements.

Installations Must Comply With:

Local, state, provincial, and national codes, laws, regulations, and ordinances.

Table of Contents

Part 1 - General Safety Information	2
A. When Servicing the Water Heating System	3
B. System Water	3
C. Freeze Protection	3
D. Water Temperature Adjustment	3
Part 2 - Prepare the Storage Tank	3
A. Locating the Storage Tank	3
B. Water Chemistry Requirements	4
Part 3 - Piping	4
A. Plumbing	4
B. Tankless Coil Connections	4
C. Hot Water Outlet	5

D. Temperature and Pressure Relief Valve	6
E. Potable Expansion Tank	6
F. Scalding	6
G. Applications	7
Part 4 - Control and Wiring	7
A. Control	7
B. Wiring	7
C. Wiring Diagram	7
Part 5 - Start-Up and Operation	7
Part 6 - Maintenance and Troubleshooting	8
Ten (10) Year Limited Warranty	10
Customer Installation Record Form	12

 WARNING	
From the Uniform Plumbing Code 2000 - Section 510 - Protection From Damage	
<p>1. All storage tanks installed in areas where they may be subjected to mechanical damage shall be suitably guarded against such damage by being installed behind adequate barriers or by being elevated or located out of the normal path of a vehicle using any such garage.</p> <p>2. In seismic zones 3 and 4, storage tanks shall be anchored or strapped to resist horizontal displacement due to earthquake motion. Strapping shall be at points within the upper one-third (1/3) and lower one-third (1/3) of its vertical dimensions. At the lower point, a minimum distance of four (4) inches (102 mm) shall be maintained above the controls with the strapping.</p> <p>3. A storage tank supported from the ground shall rest on level concrete or other approved base extending not less than three (3) inches (76 mm) above the adjoining ground level.</p> <p>4. When a storage tank is located in an attic, attic-ceiling assembly, floor-ceiling assembly, or floor-subfloor assembly where damage may result from a leaking storage tank, a watertight pan of corrosion resistant materials shall be installed beneath the storage tank with a minimum three-quarter (3/4) inch (20 mm) diameter drain to an approved location.</p>	

Part 1 - General Safety Information

This storage tank is approved for indoor installations only and is not intended for use in swimming pool applications. Clearance to combustible materials: 0" top, bottom, sides, and back. Tank must have room for service: 24" front and 6" sides are minimum recommended service clearances. (A combustible door or removable panel is acceptable front clearance.) This storage tank has been approved for closet installation and installation on combustible flooring. Install the storage tank in a location where temperature and pressure relief valve discharge or a leak will not result in damage to the surrounding area.

 WARNING	
Installer - Read all instructions in this manual before installing. Perform steps in the given order.	
User - This manual is for use only by a qualified heating installer / service technician. Have this storage tank serviced / inspected annually by a qualified service technician.	
NOTE: Obey all local codes. Obtain all applicable permits before installing the storage tank.	
NOTE: Install all system components and piping in such a manner that does not reduce the performance of any fire rated assembly.	

WARNING

NOTE: If the storage tank is exposed to the following, do not operate. Immediately call a qualified service technician.

- 1. Fire
- 2. Damage
- 3. Water

Failure to adhere to these guidelines can result in substantial property damage, severe personal injury, or death.

CAUTION

High heat sources (sources generating heat 100°F / 37°C or greater, such as stove pipes, space heaters, etc.) may damage plastic components of the storage tank as well as plastic vent pipe materials. Such damages ARE NOT covered by warranty. It is recommended to keep a minimum clearance of 8" from high heat sources. Observe heat source manufacturer instructions, as well as local, state, provincial, and national codes, laws, regulations and ordinances when installing this storage tank and related components near high heat sources.

Do not use this storage tank for anything other than its intended purpose (as described in this manual). Doing so could result in property damage and WILL VOID product warranty.

NOTICE

UNCRATING THE STORAGE TANK - Any claims for damage or shortage in shipment must be filed immediately against the transportation company by the consignee.

A. When Servicing the Water Heating System

To avoid electric shock, disconnect electrical supply before performing maintenance.

To avoid severe burns, allow storage tank and associated equipment to cool before servicing.

B. System Water

Do not use petroleum-based cleaning or sealing compounds in a water heating system. Gaskets and seals in the system may be damaged. This can result in substantial property damage.

Do not use "homemade cures" or "patent medicines". Damage to the storage tank, substantial property damage, and/or serious personal injury may result.

C. Freeze Protection

NOTE: Consider piping and installation when determining tank location. Place the storage tank as close to the boiler as possible in a location not prone to freezing.

CAUTION

Failure of the storage tank due to freeze related damage IS NOT covered by product warranty.

D. Water Temperature Adjustment

If the storage tank is going to have a set temperature above 120°F, you must use an ASSE 1017 rated mixing valve to avoid severe burns or death from scalding temperatures.

WARNING

Households with small children, disabled, or elderly persons may require a 120°F or lower temperature setting to prevent severe personal injury or death due to scalding.

Part 2 - Prepare the Storage Tank

Remove all sides of the shipping crate to allow the tank to be moved into its installation location.

A. Locating the Storage Tank

This storage tank is certified for indoor use only. DO NOT INSTALL OUTDOORS. Outdoor installations ARE NOT covered by warranty.

Choose a location for the storage tank as centralized to the piping system as possible. Also, locate the storage tank and domestic water piping where it will not be exposed to freezing temperatures. All piping should be insulated. Additionally, place the storage tank so that the drain, controls, and inlets/outlets are easily accessible.

WARNING

This storage tank must be installed upright in the vertical position as described in this manual. DO NOT attempt to install this storage tank in any other orientation. Doing so will result in improper storage tank operation and property damage, and could result in serious personal injury or death.

Ensure the location can support the entire filled weight of the storage tank. Failure to properly support the storage tank could result in property damage, severe personal injury, or death.

CAUTION

COLD WEATHER HANDLING - If the storage tank has been stored in a very cold location (BELOW 0°F) before installation, handle with care until the components come to room temperature. Failure to do so could result in damage to the storage tank.

All water heaters eventually leak. Locate the water heater where any leakage from the relief valve, related piping, tank, or connections will not result in damage to surrounding areas or lower floors of the building. Any water heater should be installed in such a manner that if it should leak the resulting flow of water will not cause damage to the area in which it is installed. National Plumbing codes require a drain pan for any water heater installation. This drain pan should be sized with a maximum depth of 2", and a minimum diameter 2" greater than the diameter of the water heater. The drain pan should empty into an open drain line. This drain line should be 3/4" ID minimum, piped to an open drain. Leakage damages ARE NOT covered by warranty. Failure to install a drain pan is the sole responsibility of the owner and/or installer. Reference UPC 2000 (Uniform Plumbing Code) Section 510 - Protection from Damage or IPC 200 (International Plumbing code) Section 504 - Safety Devices. Leakage damages ARE NOT covered by warranty.

In addition, water leak detection devices and automatic water shutoff valves are readily available at plumbing supply houses. IT IS HIGHLY RECOMMENDED BY THE MANUFACTURER TO INSTALL WATER LEAK DETECTION DEVICES AND AUTOMATIC SHUTOFF VALVES IN ANY WATER HEATER INSTALLATION WHERE A LEAKAGE OF WATER COULD RESULT IN PROPERTY DAMAGES.

NOTE: To save on heating costs and improve energy efficiency keep the distance between the boiler and storage tank to a minimum to reduce heat loss from excess piping and keep friction loss at a minimum. Ensure all piping between the boiler and storage tank is properly insulated to minimize heat loss.

The storage tank may be located some distance from the boiler provided the circulator meets flow requirements. The greater the distance from the boiler to the storage tank the longer the response will be to a call for hot water.

This storage tank must be installed vertical on a level surface.

NOTE: In the State of California, the storage tank must be braced, anchored, or strapped to avoid moving during an earthquake. Contact local utilities for code requirements in your area. Visit <http://www.dsa.dgs.ca.gov> or call 1-916-445-8100 and request instructions.

However, applicable local codes shall govern installation. For residential storage tanks of a capacity of greater than 52 gallons, consult the local building jurisdiction for acceptable bracing procedures.

NOTE: If you do not provide the minimum clearances shown in Figure 1, it might not be possible to service the storage tank without

removing it from the space.

NOTE: A combustible door or removable panel is acceptable front clearance.

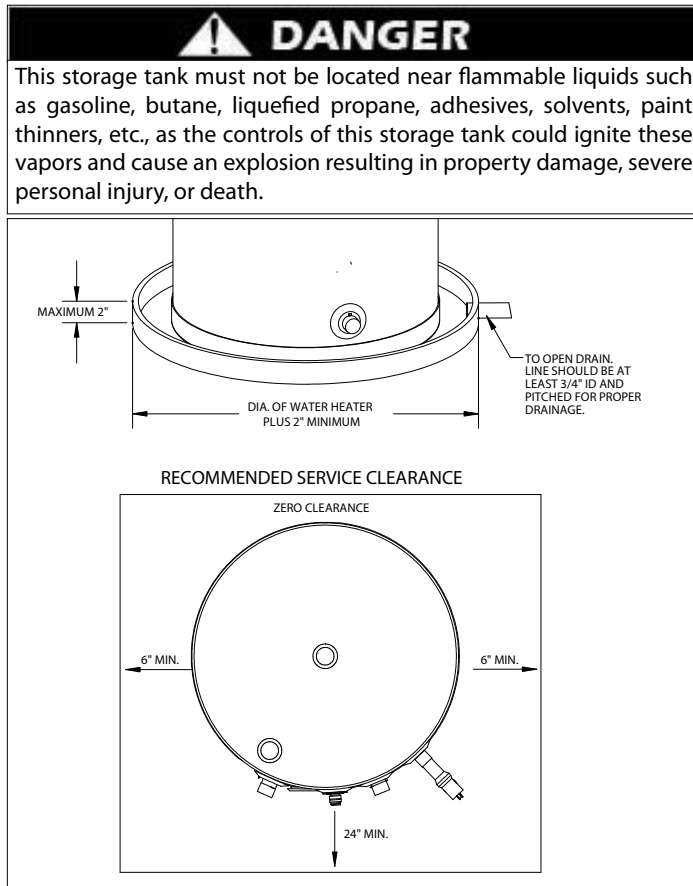

Figure 1 - Recommended Service Clearances

B. Water Chemistry Requirements

CAUTION

Chemical imbalance of the water supply may affect efficiency and cause severe damage to the storage tank and associated equipment. Water quality must be professionally analyzed to determine whether it is necessary to treat the water. Various solutions are available to adjust water quality. Adverse water quality will affect the reliability of the system. In addition, operating temperatures above 135°F will accelerate the build-up of lime scale and possibly shorten tank service life. Failure of a storage tank due to lime scale build-up, low pH, or other chemical imbalance IS NOT covered by the warranty.

The water must be potable, free of corrosive chemicals, sand, dirt, and other contaminants. It is up to the installer to ensure the water does not contain corrosive chemicals or elements that can damage the heat exchanger. Potable water is defined as drinkable water supplied from utility or well water in compliance with EPA secondary maximum contaminant levels (40 CFR Part 143.3). If the water contains contaminants higher than outlined by the EPA, water treatment is recommended and additional, more frequent maintenance may be required.

If you suspect that your water is contaminated in any way, discontinue use of the storage tank and contact an authorized technician or licensed professional.

Water pH between 6.5 and 8.5

- pH levels below 6.5 can cause an increase in the rate of corrosion. pH of 8.5 or higher can potentially cause lime scale build-up
- Maintain water pH between 6.5 and 8.5. Check with litmus paper or have it chemically analyzed by a local water treatment company.

- If the pH is not between 6.5 and 8.5, consult a local water treatment company for solutions.

Hardness less than 12 grains (200 mg/L)

- Hardness levels above the required amounts can lead to lime scale build-up throughout the system. Water below 5 grains/gallon (85 mg/L) may be over softened.
- Consult local water treatment companies for unusually hard water areas (above the required amounts) or for other treatment solutions if water is being over softened (below 5 grains/gallon [85 mg/L]).

Chloride concentration less than 100 ppm (mg/L)

- Do not fill storage tank or operate with water containing chlorides in excess of 100 ppm (mg/L).
- Using chlorinated fresh water should be acceptable as levels are typically less than 5 ppm (mg/L).
- Do not connect the storage tank to directly heat swimming pool or spa water.

Total Dissolved Solids (TDS) less than 500 ppm (mg/L)

- Total dissolved solids are minerals, salts, metals, and charged particles that are dissolved in water.
- The greater the amounts of TDS present, the higher the corrosion potential due to increased conductivity in the water.
- If using softened water to fill the storage tank, it is still possible to have high TDS. This water can be corrosive. Consult local water treatment companies for other treatment solutions to reduce this affect.

***NOTE:** To promote storage tank service life, it is strongly recommended to follow the maintenance procedures in this manual.

Part 3 - Piping

A. Plumbing

It is mandatory that all plumbing be done in accordance with federal, local, and state plumbing codes and practices. Failure to properly install the storage tank WILL VOID the warranty. It is also necessary to use both thread tape and pipe dope on all mechanical plumbing connections.

CAUTION

When filling the storage tank, open a hot water tap to release air in the tank and piping. Failure to do so could lead to improper operation and damage to components.

The use of heat, such as blow torches, near the tank may cause distortion to the high density polyethylene wrapper. Such damage is NOT covered by warranty. Exercise caution whenever using heat sources near tank.

Never use dielectric fittings or galvanized steel fittings on any domestic water connections. Use only copper or brass fittings. Failure to do so will result in premature storage tank failure. Such failure IS NOT covered by warranty.

B. Tankless Coil Connections

Use a 3/4" nominal minimum pipe size. On the tank, the tankless inlet is to be connected to a bronze or stainless steel circulator with the arrow pointing away from the tank and toward the tankless coil. This pipe will also have a tee for the cold supply to the tankless coil. (An optional check valve may be installed between the cold supply line and circulator to prevent short circulating the tankless coil. This may cause poor supply pressure, or noisy operation depending upon the type of installation.)

On the tank, tankless outlet, use both thread tape and pipe dope and connect a 3/4" (minimum) tube adapter and connect this to the hot tankless coil outlet on the boiler.

NOTE: See "Typical Installation", Figure 3.

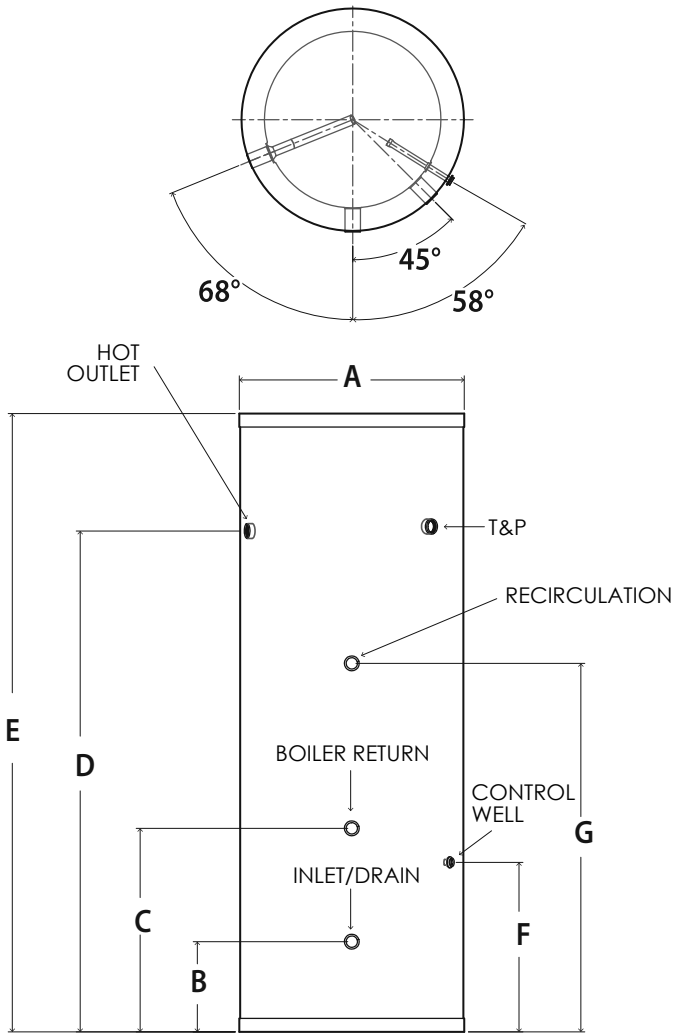

30/45/60/80/119 GALLON

MODEL	DIMENSIONS							TEST PRESSURE	WORKING PRESSURE	WEIGHT (LBS)	CONNECTION SIZES
	A	B	C	D	E	F	G				
SSU EVO - 30CB	19.84"	7.95"	17.95"	33.54"	42.125"	14.95"	28.5"	300 PSI	150 PSI	70	3/4" NPT
SSU EVO - 45CB	19.84"	7.95"	17.95"	44.17"	54.625"	14.95"	32.5"			88	
SSU EVO - 60CB	22.99"	8.66"	18.66"	43.31"	52.625"	15.66"	32.9"			105	
SSU EVO - 80CB	22.99"	8.66"	18.66"	59.89"	72"	15.66"	37.6"			135	1-1/2" NPT
SSU EVO - 119CB	28.11"	9.65"	19.65"	56.49"	74"	16.65"	35.4"			223	

Figure 2 - Specifications and Dimensions

C. Hot Water Outlet

30 - 60 Gallon Storage Tanks: Use 3/4" NPT nominal pipe size. A T&P port is included.

80 and 119 Gallon Storage Tanks: Use 1 1/2" NPT nominal pipe size. A T&P port is included.

NOTE: For more information, see "G. Applications".

D. Temperature and Pressure Relief Valve

On all models, an appropriate temperature and pressure (T&P) valve must be supplied and installed as detailed in the piping diagrams in this installation manual.

Use both thread tape and pipe dope to install an NPT brass T&P relief valve for hot water storage tanks, as required by local codes but not less than valves certified as meeting the requirements for relief valves for hot water heaters (ANSI Z21.22 and CAN 1-4.4) by a nationally recognized lab that maintains periodic inspection of production listed equipment. Make sure the relief valve is sized to the BTU/Hour capacity of the boiler. The T&P valve must be plumbed down so discharge can exit at least 6" above the structural floor. The relief line cannot be in contact with any live electrical parts. If the relief valve constantly weeps install an expansion tank. See expansion tank manufacturer's instructions for suggestions.

WARNING

Do not thread a cap or plug into the relief valve or relief valve line under any circumstances! Explosion and property damage, serious injury, or death may result.

To avoid water damage or scalding due to relief valve operation:

- Discharge line must be connected to relief valve outlet and run to a safe place of disposal. Terminate the discharge line in a manner that will prevent possibility of severe burns or property damage should the relief valve discharge.
- Discharge line must be as short as possible and the same size as the valve discharge connection throughout its entire length.
- Discharge line must pitch downward from the valve and terminate at least 6" above the floor drain, making discharge clearly visible.
- The discharge line shall terminate plain, not threaded, with a material serviceable for temperatures of 375°F or greater.
- Do not pipe discharge to any location where freezing could occur.
- No valve may be installed between the relief valve and storage tank or in the discharge line. Do not plug or place any obstruction in the discharge line.
- Test the operation of the relief valve after filling and pressurizing the system by lifting the lever. Make sure the valve discharges freely. If the valve fails to operate correctly, immediately replace with a new properly rated relief valve.
- Test T&P valve at least once annually to ensure the waterway is clear. If valve does not operate, turn the storage tank "off" and call a plumber immediately.
- Take care whenever operating relief valve to avoid scalding injury or property damage.

FAILURE TO COMPLY WITH THE ABOVE GUIDELINES COULD RESULT IN FAILURE OF RELIEF VALVE OPERATION, RESULTING IN POSSIBILITY OF SUBSTANTIAL PROPERTY DAMAGE, SEVERE PERSONAL INJURY, OR DEATH.

RE-INSPECTION OF T&P RELIEF VALVES: T&P valves should be inspected AT LEAST ONCE EVERY THREE YEARS, and replaced if necessary, by a licensed plumbing contractor or qualified service technician to ensure that the product has not been affected by corrosive water conditions and to ensure that the valve and discharge line have not been altered or tampered with illegally. Certain naturally occurring conditions may corrode the valve and its components over time, rendering the valve inoperative. Such conditions can only be detected if the valve and its components are physically removed and inspected. **Do not attempt to conduct an inspection on your own.** Contact your plumbing contractor for a re-inspection to assure continued safety.

WARNING
FAILURE TO RE-INSPECT THE T&P VALVE AS DIRECTED COULD RESULT IN UNSAFE TEMPERATURE AND/OR PRESSURE BUILD-UP WHICH CAN RESULT IN PROPERTY DAMAGE, SERIOUS PERSONAL INJURY, OR DEATH.

E. Potable Expansion Tank

A potable hot water expansion tank may be required to offset heated water expansion. If there is a back flow preventer or any other type of no return or check valve in the system a thermal expansion tank IS MANDATORY. The expansion tank must be sized for the entire water volume of the hot water system. A weeping relief valve indicates the need for an expansion tank. See the Typical Expansion Tank example in the Piping section for details.

F. Scalding

A water heating system can deliver scalding water. Be careful whenever using hot water to avoid scalding injury. Certain appliances such as dishwashers and automatic clothes washers may require increased water temperatures. By setting the thermostat to obtain the increased water temperature required by these appliances you may create the potential for scald injury.

To protect against injury, install a mixing valve in the water system. This valve will reduce point of use discharge temperatures by mixing cold and hot water in branch supply lines. Such valves are available from your local plumbing supplier.

Table 3 details the relationship of water temperature and time with regard to scald injury and may be used as a guide in determining the safest water temperature for your applications.

DANGER



Water temperature over 125°F can cause severe burns instantly or death from scalds. Children, disabled and elderly are at highest risk of being scalded. See instruction manual before setting temperature at water heater. Feel water before bathing or showering. Temperature limiting valves are available, see manual.

Approximate Time / Temperature Relationships in Scalds	
120°F	More than 5 minutes
125°F	1 1/2 to 2 minutes
130°F	About 30 seconds
135°F	About 10 seconds
140°F	Less than 5 seconds
145°F	Less than 3 seconds
150°F	About 1 1/2 seconds
155°F	About 1 second

Table 1 - Approximate Time / Temperature Relationships in Scalds

G. Applications

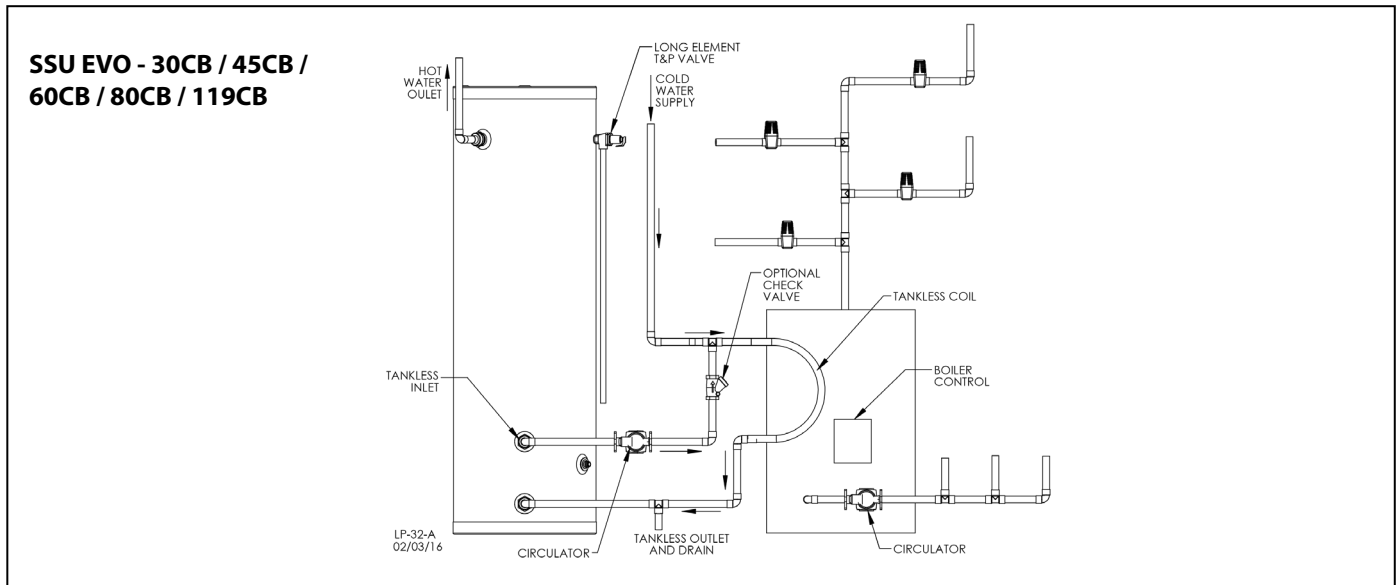

Figure 3 - Typical Storage Tank Installation - SSU EVO - 30CB / 45CB / 60CB / 80CB / 119CB

PIPING NOTES:

The following notes are applicable to all of the piping applications demonstrated on this page.

1. Check valves are optional. Circulators may have Internal Flow Checks (IFCs).
2. If a backflow preventer or no return valve is installed a thermal expansion tank suitable for potable water must be sized and installed on the cold water inlet between the storage tank and the backflow preventer.

Part 4 - Control and Wiring

A. Control

Install control element into the control well and tighten into place with screws on the control body. Thermal conductive paste is recommended. Once the control is operational, it is important to make sure the control is maintaining the desired operating temperature.

B. Wiring

Wiring is to be done in accordance with all applicable local and state codes. Turn off all power related to the water heating system before starting any wiring procedures. It is recommended that a disconnect switch be installed between the boiler control and the storage tank.

CAUTION

When wiring the controls be sure to label all wires to ease future maintenance. Wiring errors can cause improper and dangerous operation.

C. Wiring Diagram

Part 5 - Start-Up and Operation

1. Fill the storage tank by opening the cold water shut-off valve. Make certain any drain valves are completely closed. Purge air from the system by opening a hot water outlet at a fixture in a kitchen or bathroom. When water flows freely from the outlet, the system is purged.

CAUTION

When filling the storage tank, open a hot water tap to release air in the tank and piping to ensure proper storage tank operation. Failure to ensure the storage tank is full before turning on the system could result in damage to the water heating system and property damage. Such damages ARE NOT covered by warranty.

2. Check the system for leaks.

CAUTION

Fix any leaks before continuing the installation. Failure to do so could result in property damage or personal injury.

3. After ensuring there are no leaks within the system, flush the system to clear any soldering residue. Many soldering fluxes contain Zinc Chloride, which can corrode stainless steel.

Draw at least three times the volume of the storage tank to properly flush the system.

4. Initiate a call for hot water. Ensure each zone valve or circulator operates only when its thermostat calls for heat. Purge each zone of air to ensure proper operation.

5. Set the storage tank to the desired temperature. Boiler high limit should be set at least 20°F higher than the storage tank temperature setting. Set the low limit of the control at the minimum setting - this will call the burner on only to satisfy the tank control.

A storage tank temperature setting of 120°F is recommended. However, a lower temperature setting may be required to comply with local and state codes for normal operation. Installation conditions may require a higher or lower temperature setting. A mixing valve in conjunction with a high temperature setting may be used for high

demand applications (spas, hot tubs, whirlpools).

6. When the system is completely flushed, purged of air, and the temperature is set, turn on the water heating system. Observe operation. Ensure the boiler shuts down after the storage tank set point is satisfied.

Part 6 - Maintenance and Troubleshooting

Periodic maintenance should be performed by a qualified service technician to ensure all equipment is operating safely and efficiently. The owner should make necessary arrangements with a qualified heating contractor for periodic maintenance of the water heating system. Installer must also inform the owner that the lack of proper care and maintenance may result in hazardous conditions.

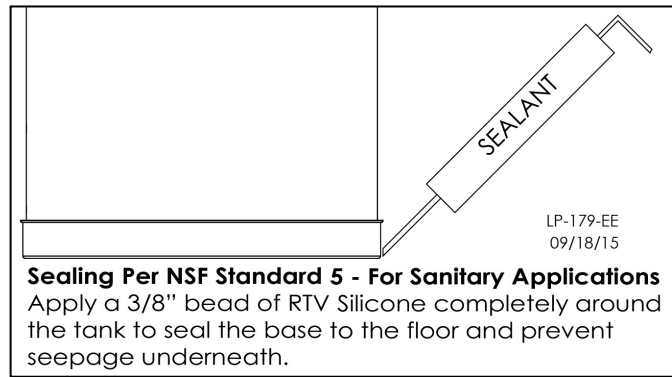



Figure 4 - Sealing the Storage Tank for Sanitary Applications

Annual Maintenance Activities		Date Last Completed			
System		1st Year	2nd Year	3rd Year	4th Year
Piping	Check system piping for any sign of leakage; make sure pipes are properly supported.				
Visual	Do a full visual inspection of all system components. Ensure all components (water treatment systems, mixing valves, circulators, etc.) are operating properly and have been maintained.				
Functional	Test all functions of the system. Perform any maintenance required by local codes. Verify system pressure is in the safe operating range.				
Temperatures	*Verify safe settings on Mixing Valve (if installed in system).				
Electrical					
Smoke and CO Detectors	*Verify devices are installed and working properly. Change batteries if necessary.				
Circuit Breakers	Check to see that the circuit breaker is clearly labeled. Exercise circuit breaker.				
Connections	Check wire connections. Make sure they are tight.				
Relief Valve and Drain Valve					
Relief Valve	Lift and release the relief valve on the storage tank. Make certain that the valve operates properly by allowing several gallons to flush through the discharge line. Replace if valve is blocked or does not operate properly. NOTE: TAKE CAUTION WHEN OPERATING RELIEF VALVE. DISCHARGED WATER MAY PRESENT A SCALD RISK.				
Drain Valve	Open the drain valve and drain a few quarts of water from the bottom of the tank to flush any hard water deposits. Replace if valve is blocked or does not operate properly. NOTE: TAKE CAUTION WHEN OPERATING DRAIN VALVE. DRAINED WATER MAY PRESENT A SCALD RISK.				
Final Inspection					
Checklist	Verify that you have completed the entire checklist. WARNING: FAILURE TO DO SO COULD RESULT IN SERIOUS INJURY OR DEATH.				
Homeowner	Review what you have done with the homeowner.				
Initial and Date after Inspection / Service. Continue Inspections Annually beyond the Fourth Year.					

Table 2 - Maintenance Activities Checklist - *If Applicable to System

Troubleshooting			
No Hot Water		Not Enough Hot Water	
Problem	Possible Solution	Problem	Possible Solution
Zone valve not opening	Open manually to replace	Zone valve restriction	1" full bore replace zone valve
Circulator not operating	Check or replace	Circulator arrow reversed	Reverse circulator
Tank control set too low	Raise tank temperature*	Tank temperature too low	Raise tank temperature*
Control set too low	Raise control temperature	Boiler temperature too low	Raise boiler temperature
Wiring incorrect	Check wiring	Boiler sized too small	Check sizing chart
Tank control failure	Replace control	Tank sized too small	Check sizing chart
Zone valve failure	Replace valve	Demand flow rate too high	Install mixing valve. Raise tank temperature
Circulator failure	Replace circulator	Air trap in loop	Purge air
Air trap in loop	Purge air		Install flow regulator
		Heat and tank come on together	Check wiring or set indirect as priority over heating
			Draw tank down and lower thermostat. Recheck.
		Not enough space heat	Boiler sized too small. Consult chart.
		Slow recovery	Circulator head capacity too low
T&P Valve Discharges		Hot Tubs, Spas, Multiple Showers, High Demand	
Problem	Possible Solution	Problem	Possible Solution
Tank temperature too high	Lower tank temperature	Pressure too low	Check line pressure for restriction
Water expands when heated	Install expansion tank	Tank recovery slow	Slow startup boiler. See chart
Water pressure too high	Install pressure reducing valve	Not enough hot water	Boiler sized too small. See chart
			Check flow rate. Compare to chart
Demand too great. Check flow rates and compare to chart. Install mixing valve and/or flow restricting valve and raise tank and boiler temperature.*			

Table 3 - Troubleshooting - *See scald warning below.

 WARNING
The risk of scald injury increases as you increase water temperature. Use a water tempering or mixing valve and extreme caution when using hot water to avoid scald injury. Consult codes for conformance. Failure to follow the instructions in this warning statement could result in serious personal injury or death from scalds.

CAUTION
If draining of the storage tank is necessary, open the T&P valve or a hot water tap to prevent vacuum buildup in the tank and piping.

**Coil Booster Stainless Steel Storage Tank
Ten (10) Year Limited Warranty
For Residential and Commercial Use**

HTP warrants each coil booster stainless steel storage tank to be free from defects in materials and workmanship according to the following terms, conditions, and time periods. UNLESS OTHERWISE NOTED THESE WARRANTIES COMMENCE ON THE DATE OF INSTALLATION. This limited warranty is only available to the **original consumer purchaser** (hereinafter "Owner") of the storage tank, and is non-transferable.

COVERAGE

A. This warranty covers the storage tank assembly ONLY. The storage tank assembly consists of a stainless steel storage tank, insulation, and outer jacket.

B. Should a defect or malfunction result in a leakage of water from the storage tank within the above-stated warranty periods due to defective material or workmanship, malfunction, or failure to comply with the above warranty, with such defect or malfunction having been verified by an authorized HTP representative, HTP will replace the defective or malfunctioning storage tank with a replacement of the nearest comparable model available at the time of replacement. The replacement storage tank will be warranted for the unexpired portion of the applicable warranty period of the original storage tank.

C. In the event of a leakage of water of a replacement storage tank due to defective material or workmanship, malfunction, or failure to comply with the above warranty, HTP reserves the right to refund to the Owner the published wholesale price available at the date of manufacture of the original storage tank.

D. If government regulations, industry certification, or similar standards require the replacement storage tank to have features not found in the defective storage tank, the Owner will be charged the difference in price represented by those required features. If the Owner pays the price difference for those required features and/or to upgrade the size and/or other features available on a new replacement storage tank, the Owner will also receive a complete new limited warranty for that replacement storage tank.

E. If at the time of a request for service the Owner cannot provide a copy of the original sales receipt or the warranty registration, the warranty period for the storage tank shall then end ten (10) years from the date of manufacture of the storage tank and NOT the date of installation of the storage tank.

F. This warranty extends only to storage tanks utilized in heating applications that have been properly installed by qualified professionals based upon the manufacturer's installation instructions.

G. It is expressly agreed between HTP and the Owner that repair, replacement, or refund are the exclusive remedies of the Owner.

OWNER RESPONSIBILITIES

The Owner or Qualified Installer / Service Technician must:

1. Have a relief valve bearing the listing marks of the American Society of Mechanical Engineers (ASME) installed with the storage tank assembly in accordance with federal, state, and local codes.
2. Have a vacuum relief valve certified to ANSI Z21.22 - Relief Valves for Hot Water Supply Systems - installed with the storage tank assembly in accordance with federal, state, and local codes and in installations prone to vacuum related damages.
3. Maintain the storage tank in accordance with the maintenance procedure listed in the manufacturer's provided instructions. Preventive maintenance can help avoid any unnecessary breakdown of the storage tank and keep it running at optimum efficiency.
4. Maintain all related system components in good operating condition.
5. Use the storage tank in an open system, or in a closed system with a properly sized and installed thermal expansion tank.

6. Use the storage tank at water pressures not exceeding the working pressure shown on the rating plate.

7. Keep the storage tank free of damaging scale deposits.

8. Make provisions so if the storage tank or any component or connection thereto should leak, the resulting flow of water will not cause damage to the area in which it is installed.

WARRANTY EXCLUSIONS

This limited warranty will not cover:

1. Any storage tank purchased from an unauthorized dealer.
2. Any storage tank not installed by a qualified heating installer / service technician, or installations that do not conform to ANSI, CSA, and/or UL standards, as well as any applicable national or local building codes.
3. Service trips to teach the Owner how to install, use, maintain, or to bring the storage tank installation into compliance with local building codes and regulations.
4. The workmanship of any installer. The manufacturer disclaims and does not assume any liability of any nature caused by improper installation, repair, or maintenance.
5. Electricity or fuel costs, or increased or unrealized savings for same, for any reason whatsoever.
6. Any water damage arising, directly or indirectly, from any defect in the storage tank or component part(s) or from its use.
7. Any incidental, consequential, special, or contingent damages or expenses arising, directly or indirectly, from any defect in the storage tank or the use of the storage tank.
8. Failure to locate the storage tank in an area where leakage of the tank or water line connections and the relief valve will not result in damage to the area adjacent to the storage tank or lower floors of the structure, as well as failure to install the storage tank in or with a properly sized drain pan routed to an approved drainage location.
9. Any failed components of the system not manufactured by HTP as part of the storage tank.
10. Storage tanks repaired or altered without the prior written approval of HTP.
11. Damages, malfunctions, or failures resulting from improper installation, or failure to install the storage tank in accordance with applicable building codes/ordinances or good plumbing and electrical trade practices; or failure to operate and maintain the storage tank in accordance with the manufacturer's provided instructions.
12. Damages, malfunctions, or failures resulting from failure to operate the storage tank at pressures not exceeding the working pressure shown on the rating label.
13. Failure to operate the storage tank in an open system, or in a closed system with a properly sized and installed thermal expansion tank.
14. Failure or performance problems caused by improper sizing of the storage tank, expansion device, or piping.
15. Damages, malfunctions, or failures resulting from vacuum conditions.
16. Damages, malfunctions, or failures caused by operating the storage tank with modified, altered, or unapproved components, or any component / attachment not supplied by HTP.
17. Damages, malfunctions, or failures caused by abuse, accident, fire, flood, freeze, lightning, electrochemical reaction, acts of God and the like.
18. Tank failures (leaks) caused by operating the storage tank in a corrosive or contaminated atmosphere.
19. Failure of the tank due to the accumulation of solid materials or lime deposits.
20. Any damage or failure resulting from improper water chemistry. WATER CHEMISTRY REQUIREMENTS – Water pH between 6.5 and 8.5. Hardness less than 12 grains (200 mg/L). Chloride concentration less than 100 ppm (mg/L). TDS less than 500 ppm (mg/L).
21. Any damages, malfunctions, or failures resulting from the use of

dielectric unions.

22. Production of noise, taste, odors, discoloration, or rusty water.
23. Storage tanks replaced for cosmetic reasons.
24. Storage tanks that are not defective, but must be replaced during the warranty period as a result of reasonable wear and tear.
25. Damages, malfunctions, or failures resulting from the use of any attachment(s) not supplied by HTP.
26. Storage tanks installed outside the fifty states (and the District of Columbia) of the United States of America and Canada.
27. Storage tanks moved from the original installation location.
28. Storage tanks that have had their rating labels removed.

PROCEDURES FOR WARRANTY SERVICE REQUESTS

Any claim for warranty assistance must be made immediately upon finding the issue. First, please consult the HTP Warranty Wizard (<http://www.htpproducts.com/Warranty-Wizard.html>) to check warranty eligibility. You may also contact HTP Technical Support at 1-800-323-9651 for questions or assistance. Warranty coverage requires review and approval of the issue with HTP Technical Support or through the Warranty Wizard prior to a full unit replacement. Any claim for warranty reimbursement will be rejected if prior approval from HTP is not obtained in advance of a full unit replacement. Final determination will be made as part of the warranty claim process.

When submitting a warranty claim the following items are required:

1. **Proof of purchase or installation of the product** – Typically a copy of the invoice from the installing contractor, the receipt of the purchase of the product, or an original certificate of occupancy for a new home.
2. **Clear pictures (or video) of the following:**
 - a. Serial number tag (sticker)
 - b. The product
 - c. The product issue / failure whenever possible
 - d. A picture of the piping near the product
 - e. For gas fired products, a picture of the venting, including how it exits the building

All claims will be reviewed by HTP within three (3) business days. If additional information is required and requested by the HTP Claims Department you will have thirty (30) days to provide it. When all requested information is provided HTP will respond within three (3) business days. The claim will be automatically closed if requested information is not provided within thirty (30) days. Claims will not be reopened without HTP Warranty Supervisor approval.

During the claims process a product that must be replaced will be given a designation of either a) field scrap, or b) return to HTP. If the product must be returned to HTP, the returned product must arrive at HTP within thirty (30) days of the date of our request to return the product. After receipt of the returned product HTP may require as many as thirty (30) additional days for product testing. **NOTE: Any components or heaters returned to HTP for warranty analysis will become the property of HTP and will not be returned, even if credit is denied.**

If you have questions about the coverage of this warranty, please contact HTP at the following address or phone number: 225 DYER ST., 1st Floor. Providence, RI, 02903, Attention: Warranty Service Department, 1(800) 323-9651.

SERVICE, LABOR, AND SHIPPING COSTS

Except when specifically prohibited by the applicable state law, the Owner, and not the Manufacturer, shall be liable for and shall pay for all charges for labor or other expenses incurred in the removal, repair, or replacement of the storage tank or any component part(s) claimed to be defective or any expense incurred to remedy any defect in the product. Such charges include, but are not necessarily limited to:

1. All freight, shipping, handling, and delivery costs of forwarding a new storage tank or replacement part(s) to the owner.
2. All costs necessary or incidental in removing the defective storage tank or component part(s) and installing a new storage tank or replacement part(s).
3. All administrative fees incurred by the Owner, as well as material required to complete, and/or permits required for, installation of a new storage tank or replacement part(s), and
4. All costs necessary or incidental in returning the defective storage tank heater or component part(s) to a location designated by the manufacturer.

LIMITATIONS OF YOUR HTP WARRANTY AND REMEDIES

THE FOREGOING WARRANTIES ARE EXCLUSIVE AND ARE GIVEN AND ACCEPTED TO THE FURTHEST EXTENT UNDER APPLICABLE LAW IN LIEU OF ANY AND ALL OTHER WARRANTIES, EXPRESS OR IMPLIED, INCLUDING WITHOUT LIMITATION THE IMPLIED WARRANTIES OF MERCHANTABILITY AND FITNESS FOR A PARTICULAR PURPOSE AND ANY OBLIGATION, LIABILITY, RIGHT, CLAIM OR REMEDY IN CONTRACT OR TORT, WHETHER OR NOT ARISING FROM HTP'S NEGLIGENCE, ACTUAL OR IMPUTED. THE REMEDIES OF THE OWNER SHALL BE LIMITED TO THOSE PROVIDED HEREIN TO THE EXCLUSION OF ANY OTHER REMEDIES INCLUDING WITHOUT LIMITATION, INCIDENTAL OR CONSEQUENTIAL DAMAGES, SAID INCIDENTAL AND CONSEQUENTIAL DAMAGES INCLUDING, BUT NOT LIMITED TO, PROPERTY DAMAGE, LOST PROFIT OR DAMAGES ALLEGED TO HAVE BEEN CAUSED BY ANY FAILURE OF HTP TO MEET ANY OBLIGATION UNDER THIS AGREEMENT INCLUDING THE OBLIGATION TO REPAIR AND REPLACE SET FORTH ABOVE. NO AGREEMENT VARYING OR EXTENDING THE FOREGOING WARRANTIES, REMEDIES OR THIS LIMITATION WILL BE BINDING UPON HTP. UNLESS IN WRITING AND SIGNED BY A DULY AUTHORIZED OFFICER OF HTP. THE WARRANTIES STATED HEREIN ARE NOT TRANSFERABLE AND SHALL BE FOR THE BENEFIT OF THE OWNER ONLY.

NO OTHER WARRANTIES

This warranty gives the Owner specific legal rights. The Owner may also have other rights that vary from state to state. Some states do not allow the exclusion or limitation of incidental or consequential damages so this limitation or exclusion may not apply to the Owner.

These are the only written warranties applicable to the storage tank manufactured and sold by HTP. HTP neither assumes nor authorizes anyone to assume for it any other obligation or liability in connection with said storage tanks.

HTP reserves the right to change specifications or discontinue models without notice.

Customer Installation Record Form	
The following form should be completed by the qualified installer / service technician for you to keep as a record of the installation in case of a warranty claim. After reading the important notes at the bottom of the page, please also sign this document.	
Customer's Name	
Date of Installation	
Installation Address	
Product Name / Serial Number(s)	
Comments	
Installer's Code / Name	
Installers Phone Number	
Signed by Installer	
Signed by Customer	

IMPORTANT

Customer: Please only sign after the qualified installer / service technician has fully reviewed the installation, safety, proper operation, and maintenance of the system. If the system has any problems please call the qualified installer / service technician. If you are unable to make contact, please call your sales representative.

Distributor / Dealer: Please insert contact details.