

THE MONTHLY NEWSLETTER TO HELP OUR CLIENTS BUILD BETTER BUSINESSES

July 2017

P1: Thought Of The Month

Prioritise Your Business Growth Tasks to GROW

P2: W.A.Y.M.I.S.H.

Why Are You Making It So Hard?

P3: Dumb Criminals

This Month's Incredible Dumb Criminals True Story

P5: Target Market(s)

How To Identify Your Perfect Target Market(s)

P7: Brain Tracker

Pit Your Wits Against This Month's Brain Tracker Challenge

P8: Bet You Didn't Know

"Nothing great was ever achieved without enthusiasm."

Ralph Waldo Emerson

"Prioritise Your Business Growth Tasks To GROW"



Boo! Welcome to the July Issue of 'The Business Builder Newsletter'.

As you're reading this newsletter, it's worth pointing out that we're ALREADY over half way through 2017.

I don't know about you, but the years seem to be getting quicker and quicker?

Our lives are getting busier. There are infinitely more interruptions to our working day than ever before. Mobile phones and e-mail have become massive 'Time Vampires' sucking the time out of your day.

Never before has it been so, so important to manage your time more effectively AND more efficiently.

So let me ask you a few simple questions...

From the beginning of 2017 to the end of June, what have you accomplished in your business? How far have you moved forward? What have you changed to ensure 2017 is your best year yet?

It pains me to say this, but arguably 99% of business owners have done very little to change their business's fortunes in 2017. I sincerely hope you are NOT one of them.

Remember, if you keep doing what you've been doing, you'll get what you always got.

Adhering to the key principle of this newsletter will ensure you don't fall into the same trap as many of your competitors and other business owners: "Simply apply at least one strategy every month from this

Continued on page 2...

Why Are You Making It So Hard?

Continued from page 1...

newsletter and your business will be unrecognisable in 12 months' time."

If time or, more importantly, a lack of time is your problem, or excuse, you have to do something right now to make time.

If you don't plan to implement at least one strategy a month, you'll get to the end of each year and wonder why your business isn't a step closer to where you want it to be. It's not rocket science.

"Lack of time is NOT an excuse. You must make time to grow and manage your business"

Yes, we all have many other tasks to do each and every day. But prioritising has to be your mantra.

Nothing is more important than growing and managing your business. Therefore, you have to prioritise the tasks that move it forward. Simple.

Yet I wonder how effective you are at doing this?

Time will tell!

SA

One of the things we like to explore with clients is an area of their business that rarely gets much attention—but IS ALWAYS CLOSELY SCRUTINISED BY CUSTOMERS — and that's the buying process. In other words... how can you make it EASIER for customers to buy from you?

In their excellent book *WAYMISH: Why Are You Making It So Hard For Me To Give You My Money?* authors Ray Considine and Ted Cohn identify several areas where businesses actually make it more difficult than easy to deal with them. And like virtually everything else we recommend to clients and other business owners, it's very easy to put this right.

Now, before we look more closely at this, I strongly advise you to walk through your own buying process.

Doing this will immediately identify 'sticking points' in your sales process that you've so far probably taken for granted.

So here are the four main elements of WAYMISH that you need to focus on to make doing business as easy as possible for your customers...

W.A.Y.M.I.S.H. #1: Making Customers Wait

Having to wait for service is one of the biggest complaints in any business. It sends a message to customers that

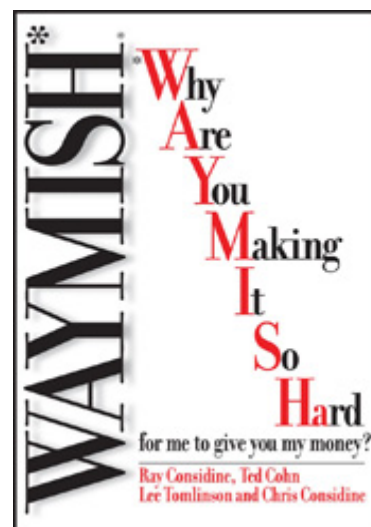

WAYMISH—How easy is it to buy from your company?

their time doesn't count... and neither do they.

Don't just think in terms of making people wait for meetings and appointments – this covers a multitude of areas...

- Answering the phone
- Answering the office door
- People in waiting areas
- Delivery of product
- Meetings/appointments/ estimates/consultations, etc.
- Management of queues
- Parking spaces available
- Engaged tones when ringing into the office

All these things irritate people, so getting them right will give you a significant edge over your competition. A good example of



Why Are You Making It So Hard?

this is the leading supermarkets, who put on extra cashiers if more than two people are waiting in a queue!

W.A.Y.M.I.S.H. #2: Accessibility

How accessible is the business? That doesn't necessarily mean your location. Here are the things you need to consider...

- Opening Times: It still amazes me that many legal firms close for lunch - stupid. Make it easy for your customers.

Ask them when they would prefer the business to open. Change opening and closing times.

Having opening and closing times to suit customers rather than staff is what you must strive to achieve.

Clearly you don't want to pander to your customers, but maybe staying open late one evening a week will be a massive hit with existing and new customers?

- Days Of Business: How many days a week is your business open? Even open on Sunday if you have to. Again, the business needs to be open on days your customers are most likely to visit. By the same token, there's no point in opening on days that customers don't buy.

- 24/7: Having a website makes the business open 24/7.
- Easy Access To Products/ Services: The good retail stores understand this completely. They know that product placement can make huge differences to the sales of certain items.

For example, manufacturers will pay a premium to the top supermarkets for their products to be placed at waist/eye level on certain aisles, because they know product placement can mean the difference between making some sales and making large volumes of sales.

W.A.Y.M.I.S.H. #3: Payment Options

Have as many payment options as possible available to customers.

You really are restricting sales if the business only offers one or two payment options.

Allow customers to pay by cash, cheque, credit cards, bank transfer, online payments, etc.

Then also look closely at structuring payments so customers can spread their payments. In the current economic climate, if you can restructure payment terms so customers pay in instalments, this can have an immediate effect on your business and, of course, your cash flow.

The point is this—what can you do to make it easier?

Continued on page 4...



Dumb Criminals

La Plata, Maryland:

Wesley Jumper, 36, and Shawn Stewart, 36, are apparently very dirty and very stupid.

How else could you explain their decision to 1) steal \$500 worth of soap and shampoo from a CVS drugstore, and 2) use a Good Humour ice cream truck as their getaway vehicle? The truck, which Stewart used for a day job, was easy enough for the police to spot, and the men were promptly arrested.

No word on what happened to the confiscated Nutty Buddies.

Why Are You Making It So Hard?

...Continued from page 3

Remember, it doesn't matter what business you're in—you can use these tactics. It also lends itself to monthly billing. For example, a restaurant can create a 'Members Club' whereby customers pay a monthly membership fee that entitles them to dine twice a month. And so on.

I urge you to look carefully at how you can incorporate this into your business. The easier you make it for your customers to buy from you – the more sales you'll generate!

W.A.Y.M.I.S.H. #4: Making It Difficult To Contact The Business

Since the advent of the internet, this has risen to almost epidemic proportions.

How often do you find a product or service online and, before buying, you want to ask a few questions? Then, to your frustration and later disgust, you can't find any way to get in contact with the supplier. It's like they've hidden their phone number and they don't want you to contact them.

This is a prime example of losing huge volumes of sales by not making it easy for people to get in contact with the business. Showcase your phone number and email



Making it easy to buy includes effectively managing your queues. If you're not in retail, there are still many areas of your business that this still applies to—such as phone queues, parking and waiting areas!

address on all your marketing pieces.

Don't make it hard.

Make it unbelievably easy for people to reach the business.

Furthermore, I advise you to scrutinise your signage.

I visit a lot of businesses, especially our clients' offices, retail outlets and restaurants.

I've often noticed, especially when visiting for the first time, how either insufficient signage or none at all makes it frustratingly hard to find them.

You must NEVER take this for granted. Having clear signage not only makes it easy for people to find you, but also

showcases and promotes your business. It's the cheapest form of advertising, you should make maximum use of it.

I like to term all these elements as your '**slippery slope**'. Once someone is interested in your business and, figuratively speaking, they step onto your slope, you make it so slippery, so easy for them to travel down it, that they can't get off – until they buy, that is! That's what W.A.Y.M.I.S.H. is all about.

Now it's your turn. Look at your own business and apply W.A.Y.M.I.S.H. to it and you'll increase your sales significantly (without spending a penny)!



How To Identify Your Perfect Target Market(s)



Steve Hackney—Helping you to quickly grow your business

So let's show you how to do this using the lawn-cutting service.

Let's say they have two prime target markets—large lawns and small lawns.

The lazy way to do this is to combine both target markets in the ad (just like 'Garden Busters' opposite). But this weakens the message significantly. What you need is two different ads—one for each target market...

Now, remember one of the golden rules of business growth is using multimedia across the 3 Business Multipliers. So, as an example, you'd want to create other Marketing Pieces such as a sales letter for each target market.

As a simple exercise, now we know who our target market is, we can easily identify properties in the local area with large lawns, for example.

We can easily get our hands on a local area map showing all properties and the amount of land each one has. Too much effort, I hear you say? Well, think about it, do the exercise once—and it's done. And you now have your target market identified perfectly.

You can then mail (or even hand-deliver) your sales letter to each home, and because it's written with the target market in mind (ones with large lawns) it will connect with them.

You then set up a simple follow-up

programme (say, once a month) to each household and within a short period of time—the business will be flourishing. And remember that's just for one target market.

Look, whether you like it or not, you have to be this detailed in your marketing. You have to put the effort in at the front end to get the rewards. But there is no other activity as important as this.

Here are our 6 key questions to help you identify your ideal target market (s)...

1. What do you do well and enjoy at the same time?

If you are offering a range of products/services, there may be one in particular which you do better than the others. If so, which types of customers could benefit most from it?

2. Which product/service is the most profitable?

If you offer more than one product or service (you must!), there will be certain ones that are more profitable than others. Once you know the answer to this, you can then ask yourself which types of customers are these products/services most suitable for.

3. Who are your best customers? Do 20% of your customers generate 80% of your profits?

Find out who your best customers are. Analyse your database or accountancy software.

What proportion of your profits do these top customers contribute? What product/service are they buying? Is there a commonality?

4. Do your best customers have any similarities?

If you sell your product/service to other businesses, what are the similarities? Look at the following indicators:

- Industry type
- Turnover



Cryptic Puzzle Of The Month

These words can all have a letter added and then be rearranged to make a new 5-letter word, e.g. noun UNION
NOUN + I = UNION.

The 7 added letters are an anagram of a 7-letter word. What is the 7-letter word, and what are the new words?

MAIL

EXIT

GOSH

CITY

NEWT

DENY

MINI

ANSWER ON PAGE 7

How To Identify Your Perfect Target Market(s)

- Geographic location
- Number of employees
- The position or job title of the senior buyer for your services
- Number of offices or retail/distribution outlets

If you sell your product to consumers, what are their similarities? Look at the following indicators:

- Income
- Joint income
- Geographic location
- Number of children
- Age
- Lifestyle habits and hobbies
- Employment type
- Their industry type
- What cars they drive

5. What is the profitability of each customer?

This is a very important exercise for you to undertake. Look at all your customers and start analysing them in terms of profit. What you'll find is the customer list can be broken down or segmented into 2-5 different profit categories. It makes sense to focus on the most lucrative groups.

In some cases, you will realise some groups are costing you money. If that's the case, you need to get rid and quick!

6. Does the business have any expertise relating to specific types of businesses or people?

You may find the business has expertise in one or more areas which benefit certain types of customers more than others. For example, the business may be a firm of chartered accountants, but 'start-up businesses' are the real area of expertise.

In this instance, it would make sense to target new and start-up businesses.

Note About New Businesses

If your business is new, it won't have any or many customers to base most of this information on. So here's what to do...

Ring up at least 15 potential prospects in each different niche that you are thinking about. 'Prospects' can be friends, business colleagues or family – it doesn't matter. Tell them you are 'thinking' of setting up a new business and you'd really like to ask them a few questions. Many people are only too happy to help. You must make it clear that you are not trying to sell them anything!

Now you can find out what they want. What's missing from their current provider? What they like and dislike, etc. This approach should give you loads of ideas for deciding which specific market(s) to focus on.

Now Answer The Following 8 Questions To Ensure You've Chosen The Right Markets

Remember, you must ask this set of questions FOR EACH TARGET MARKET YOU'VE IDENTIFIED...

- What are the main needs, wants, problems and frustrations of your target market?
- How does the product or service address each of these issues?
- Do they have the money to pay for your product?
- Will they pay a premium for a better product?
- Where are they? Can the business service them successfully in these geographic areas?
- Are there many of them? How many in total? (Depending on the product or service sold, you will want to make sure there are enough customers to ensure your healthy existence!)
- Is competition in this segment weak?
- Does the business already have credibility with the target market(s)?

This isn't essential but it will give you a head start. Those markets for which the business has relevant experience and credibility (Social Proof—testimonials, etc.) are, of course, your best and quickest options.

By answering 'YES' to the majority of these questions, you can be confident that your chosen target market(s) will be very lucrative for you. But don't forget to tailor the message to each specific target market. **SH**



Super Referral Program

We have created our Referral Scheme to reward our clients for recommending us. **We will pay you £100** when your referral has joined up to one of our packages and paid their first month's fees. **Even if your referral decides not to join us we will still give you a gift voucher as a thank you for recommending DNS.** Although we think this is a very generous amount we have decided that it is not enough so we have added an additional twist to our referral scheme! Not only do you receive £100 as a referral fee, but we also want to offer you something extra to make it even sweeter.

If 3 of your referrals join DNS in 2017 you get 50% discount off your fees for Jan 18 to Dec 18.

If 5 of your referrals join DNS in 2017 you get 100% discount off your fees for Jan 18 to Dec 18.



What Clients Say About DNS Accountants

“Genuine Interest And Commitment To Support Me”

“I have been working with Elena for over three years and have always found her to be extremely helpful. She has supported me with a wide range of business and financial queries and when I am asking something she is getting back to

she has a genuine interest and commitment to support me. “In my opinion, the way she works and her dedicated support to clients should be a reference the accountancy field. I would not hesitate to recommend her to anyone who is looking for professional accounting services.”
*Albert Nemet
 Nemet Management Consulting Ltd*



Brain Tracker: How Many Words Can You Find?

Using the BrainTracker grid below, how many words can you find? Each word must contain the central C and no letter can be used twice, however, the letters do not have to be connected. Proper nouns are not allowed, however, plurals are. Can you find the nine letter word?

Excellent: 11 words. Good: 9 words. Average: 8 words.

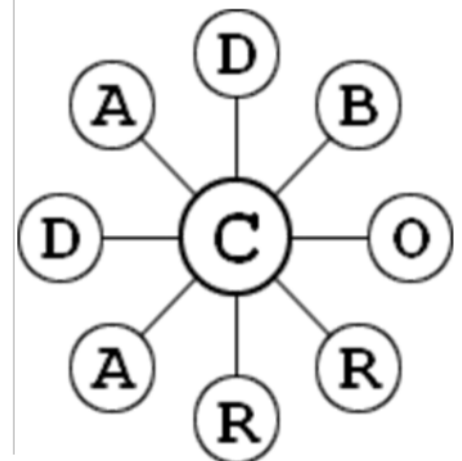

We are experts at helping our clients financially manage and grow their business!

“Outstanding Focus, Knowledge and Professionalism”

me promptly and in a professional manner.

“The personal service I receive and the interest she shows in my business assures me that

“This is to place on record the outstanding focus, knowledge and professional in Abdul Shakoor in all his engagements with Vichag to date. Really appreciate his speed and courtesy in replying to emails and closure of actions on him. He is truly an asset to DNS.

“Overall I am happy to say that your Payroll team and VAT team supporting Abdul are doing a marvellous job. Please pass on my best wishes to them.

“Best of luck for a steady growth of DNS in the years to come.”
*Subbarao Chaganty
 Vichag Limited*

CRYPTIC PUZZLE ANSWER			
MAIL	+	C	= CLAIM
EXIT	+	S	= EXIST
GOSH	+	T	= GHOST
CITY	+	H	= ITCHY
NEWT	+	I	= TWINE
DENY	+	E	= NEEDY
MINI	+	M	= MINIM

And the letters CSTHIEM spell CHEMIST.

Bet You Didn't Know



- If you can see a rainbow you must have your back to the sun.
- The Mad Hatter in Alice in Wonderland was a symbolic character for the hat makers in towns of the late 1800's. The large felt hats of the day had supports made out of lead. The lead caused an organic form of psychosis (brain damage) to develop in the hat makers causing them to be declared crazy.
- The number 57 on a Heinz ketchup bottle represents the number of varieties of pickle the company once had.
- A lightning bolt generates temperatures five times hotter than those found at the sun's surface!
- A 'jiffy' is an actual unit of time for 1/100th of a second.
- The sentence "The quick brown fox jumps over a lazy dog." uses every letter of the alphabet!
- Thomas Edison, light bulb inventor, was afraid of the dark!
- A crocodile really does produce tears, but they're not due to sadness. The tears are glandular secretions that work to expel excess salt from the eyes. Hence, "crocodile tears" are false tears.
- Babies are born with 300 bones, but by adulthood we have only 206 in our bodies.
- In Disney's Fantasia, the Sorcerer's name is Yensid, which is Disney spelled backward.

Our Contact Details:

DNS Accountants

Pacific House
382 Kenton Road
Harrow HA3 8DP
Tel: 03300 886686
Email: info@dnsaccountants.co.uk
www.dnsaccountants.co.uk



© Copyright DNS Accountants

Ask Us About Our Unique Accounting Services...

Key Services:

-  *Business Start-up Service*
-  *Tax Planning*
-  *Company Accounts*
-  *Self Assessment Tax Returns*
-  *Construction Industry Scheme*
-  *Landlord Property Tax*
-  *VAT*
-  *Payroll*
-  *Bookkeeping*

Other Unique Benefits:

- Small Business and Contractor Experts
- Award Winning Accountants
- Free Online Accounting Software
- Expert In-house Tax Consultants
- No Penalty Guarantee

**CALL US ON 03300 886686 TO ARRANGE
A FREE NO OBLIGATION MEETING**

