

NXR thermal overload relay

Overview

Applicable scope

NXR thermal overload relays (hereinafter abbreviated as thermal relays) are suitable for overload and phase loss protection for uninterrupted or intermittent AC motors with AC frequency of 50 Hz/60 Hz, a voltage up to 690 V, and a current of (0.1-630)A.

The thermal relays also provide temperature compensation, action indication, automatic and manual reset, stop, and testing functions. The products are characterized by stable and reliable performance. The thermal relays can be plugged into contactors or installed independently.

Compliant standards: IEC/EN 60947-4-1, IEC/EN 60947-5-1.

Structural characteristics

- Three-phase bi-metal sheet type or electronic type (NXR-200, NXR-630), with a tripping level of 10A
- With phase loss protection
- With a device for continuous adjustment of setting current
- With temperature compensation
- With action indication
- With testing mechanism
- With stop bottom
- With manual and automatic reset button (NXR-200 and NXR-630 only have manual reset)
- With one NO contact and one NC contact that are electrically separable
- Installation method: Plugged into contactor (NXR-12, 25, 38, 100) or installed independently (NXR-200, 630)
- Protection characteristics

Operation environment

Type	Operation and installation conditions
Installation type	III
Pollution degree	3
Compliant standards	IEC/EN 60947-4-1, IEC/EN 60947-5-1
Certification mark	CE
Enclosure protection degree	IP20 (NXR-12, 25, 38, 100)
Ambient temperature	Operation temperature limits: -35°C~+70°C. Normal operation temperature range: -5°C~+40°C. The 24-hour average temperature should not exceed +35°C. For use beyond the normal operation temperature range, see "Instructions for use in abnormal conditions" in the annex.
Altitude	Not exceeding 2000m above sea level
Atmospheric conditions	The relative humidity should not exceed 50% at the upper temperature limit of +70°C. A higher relative humidity is allowed at a lower temperature, e.g. 90% at +20°C. Special precautions should be taken against occasional condensation due to humidity variations.
Installation conditions	The angle between the installation surface and the vertical surface should not exceed ±5°.
Shock and vibration	The product should be installed in places without significant shaking, shock, and vibration.



Description

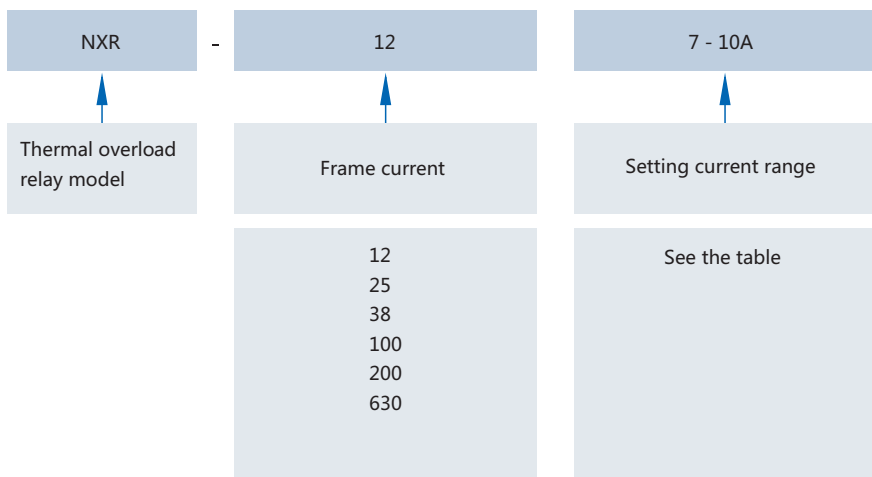

Frame	Setting current
12	0.1-0.16A
	0.16-0.25A
	0.25-0.4A
	0.4-0.63A
	0.63-1A
	1-1.6A
	1.25-2A
	1.6-2.5A
	2.5-4A
	4-6A
	5.5-8A
	7-10A
9-12A	

Frame	Setting current
25	0.1-0.16A
	0.16-0.25A
	0.25-0.4A
	0.4-0.63A
	0.63-1A
	1-1.6A
	1.25-2A
	1.6-2.5A
	2.5-4A
	4-6A
	5.5-8A
	7-10A
9-13A	
12-18A	
17-25A	

Frame	Setting current
38	23-32A
	30-38A
100	23-32A
	30-40A
	37-50A
	48-65A
	55-70A
200	63-80A
	80-93A
	80-100A
630	80-160A
	100-200A
	125-250A
	200-400A
	315-630A

Selection example:

"NXR-25 7-10A" represents a NXR 3P thermal overload relay with a frame current class of 25 and a setting current range between 7A and 10A.

NXR thermal overload relay

Quick selection and matching table

Product appearance	Rated current A	Specification of matching fuse (RT16 recommended) A	Model of matching contactor
		gG	
 <p>NXR-12</p>	0.1~0.16	2	 <p>NXC-06M, 09M, 12M</p>
	0.16~0.25	2	
	0.25~0.4	2	
	0.4~0.63	2	
	0.63~1	4	
	1~1.6	4	
	1.25~2	6	
	1.6~2.5	6	
	2.5~4	10	
	4~6	16	
	5.5~8	20	
	7~10	20	
9~12	25		
 <p>NXR-25</p>	0.1~0.16	2	 <p>NXC-06, 09, 12, 16, 18, 22, 25, 32, 38</p>
	0.16~0.25	2	
	0.25~0.4	2	
	0.4~0.63	2	
	0.63~1	4	
	1~1.6	4	
	1.25~2	6	
	1.6~2.5	6	
	2.5~4	10	
	4~6	16	
	5.5~8	20	
	7~10	20	
9~13	25		
12~18	35		
17~25	50		
 <p>NXR-38</p>	23~32	63	 <p>NXC-25, 32, 38</p>
	30~38	80	
 <p>NXR-100</p>	23~32	63	 <p>NXC-40, 50, 65, 75, 85, 100</p>
	30~40	100	
	37~50	100	
	48~65	100	
	55~70	125	
	63~80	125	
	80~93	160	
80~100	160		
 <p>NXR-200</p>	80~160	315	 <p>NXC-120, 160, 185, 225</p>
	125~200	315	
 <p>NXR-630</p>	125~250	800	 <p>NXC-225, 265, 330, 400, 500, 630</p>
	200~400	800	
	315~630	800	

NXR thermal overload relay

Parameters

Item	NXR-12	NXR-25	NXR-38	NXR-100	NXR-200	NXR-630		
Current level	12	25	38	100	200	630		
Rated insulation voltage V	690	690	690	690	690	690		
Rated impulse withstand voltage V	6000	6000	6000	6000	6000	6000		
Enclosure protection degree	IP20	IP20	IP20	IP20	-	-		
Phase loss protection	Yes	Yes	Yes	Yes	Yes	Yes		
Manual and automatic reset	Yes	Yes	Yes	Yes	Manual	Manual		
Temperature compensation	Yes	Yes	Yes	Yes	Yes	Yes		
Trip indication	Yes	Yes	Yes	Yes	Yes	Yes		
Test button	Yes	Yes	Yes	Yes	Yes	Yes		
Stop button	Yes	Yes	Yes	Yes	Yes	Yes		
Installation method	Plugged	Plugged	Plugged	Plugged	Independent	Independent		
Integrated auxiliary contact	1NO+1NC	1NO+1NC	1NO+1NC	1NO+1NC	1NO+1NC	1NO+1NC		
AC-15 380V/400V/415V rated current A	1.5	1.5	1.5	1.5	1.5	1.5		
DC-13 220V rated current A	0.2	0.2	0.2	0.2	0.2	0.2		
Conductor cross section mm ²	Main circuit	Single-core or stranded wire	1~4	1~6	4~10	4~35	25~95	50~2×185
		Wiring screw	M3.5	M4	M4	M10	M8	M10
		Tightening torque (N·m)	0.8	0.8	0.8	0.8	1.2	1.2
	Auxiliary circuit	Single-core or stranded wire	1~2.5	1~2.5	1~2.5	1~2.5	1~2.5	1~2.5
		Wiring screw	M3.5	M3.5	M3.5	M3.5	M3.5	M3.5
		Tightening torque (N·m)	1.2	1.7	1.7	10	10	20

Protection characteristics

Item	No.	Multiples of setting current		Action time	Test conditions
Overload protection	1	1.05		Without action in 2 hours	Start from cold state
	2	1.2		Act within 2 hours	Start from hot state (after No. 1)
	3	1.5		Act within 2 minutes	Start after thermal equilibrium is reached under setting current
	4	7.2		2s < T _p ≤ 10s	Start from cold state
Phase loss protection	5	Any two phases	The other phase	Without action in 2 hours	Start from cold state
		1.0	0.9		
	6	1.15	0	Act within 2 hours	Start from hot state (after No. 5)

Trip characteristics

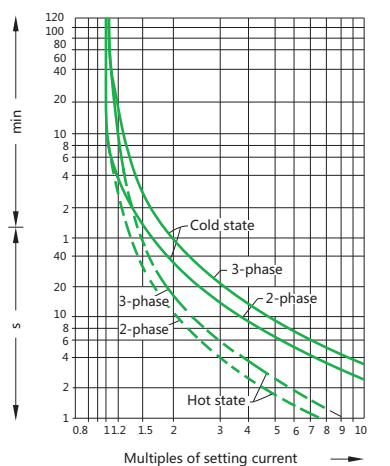

Thermal relay time Vs current characteristics curve (+20°C)

NXR thermal overload relay

Product front view



Dimensions and installation

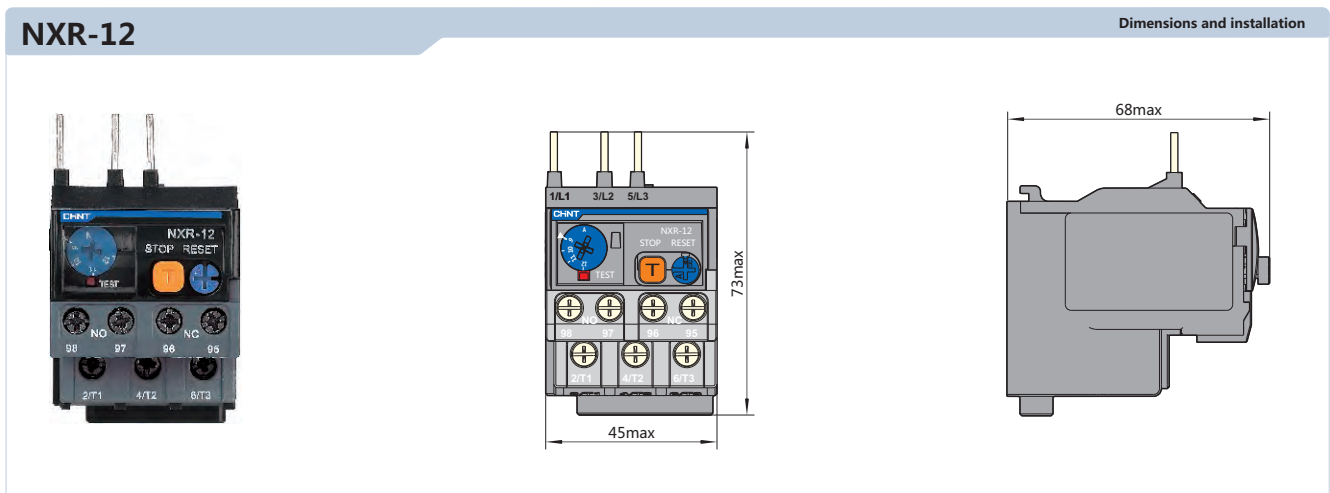

NXR thermal overload relay

NXR-25

Dimensions and installation

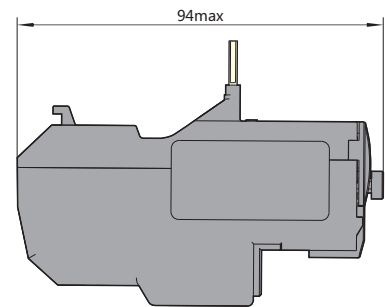
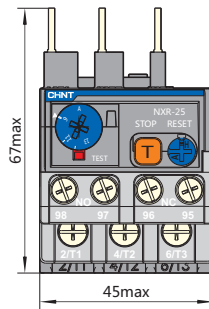

NXR-38

Dimensions and installation

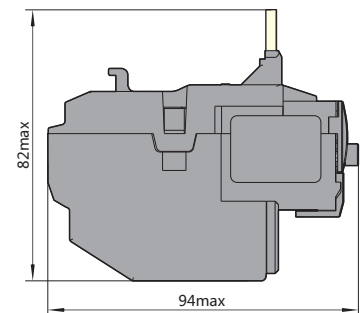
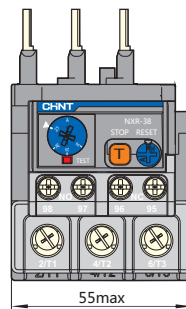

NXR-100

Dimensions and installation

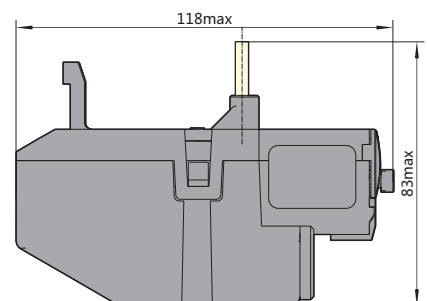
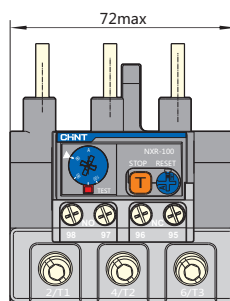

NXR thermal overload relay

NXR-200

Dimensions and installation

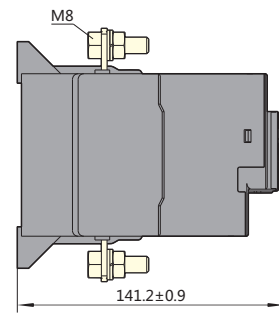
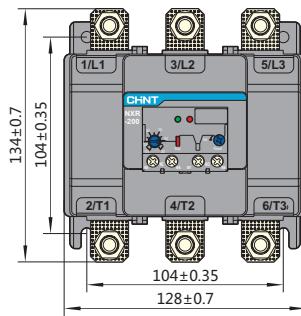

NXR-630

Dimensions and installation

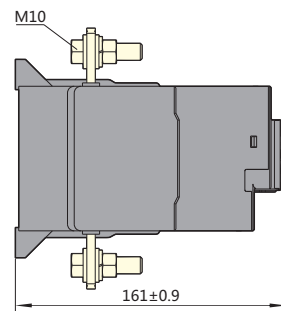
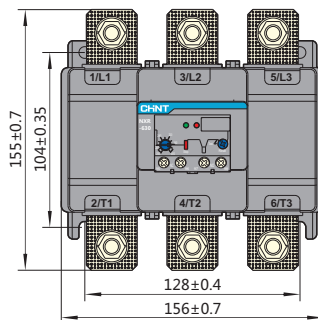

Sizes of combination with contactors

NXC-06M + NXR-12

Dimensions and installation

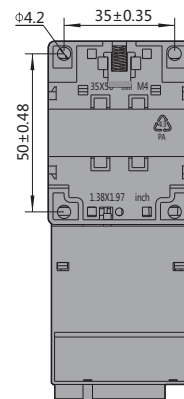
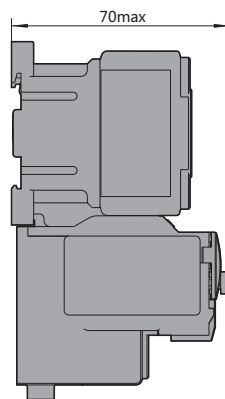
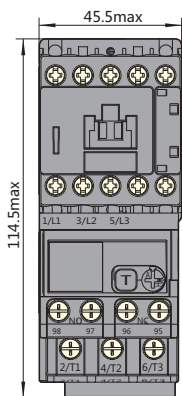

NXR thermal overload relay

NXC-09 + NXR-25

Dimensions and installation

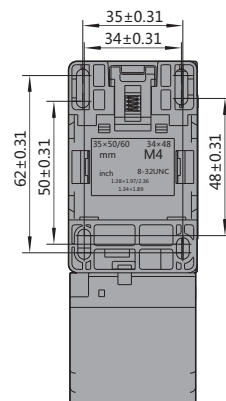
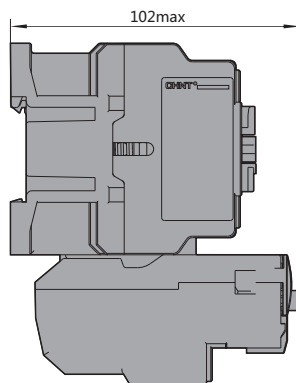
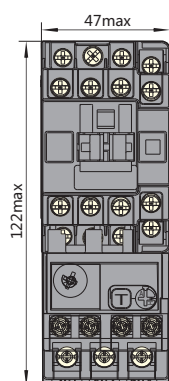

NXC-18 + NXR-25

Dimensions and installation

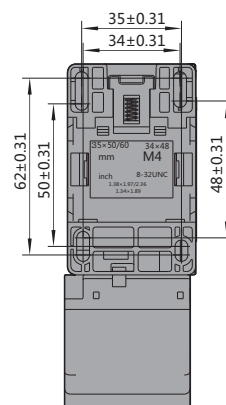
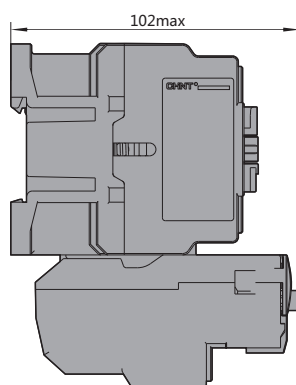
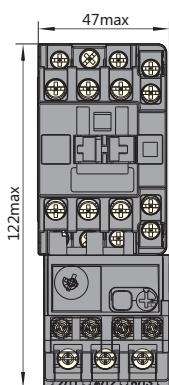

NXC-38 + NXR-25

Dimensions and installation

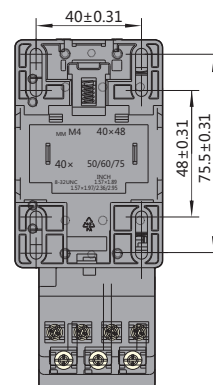
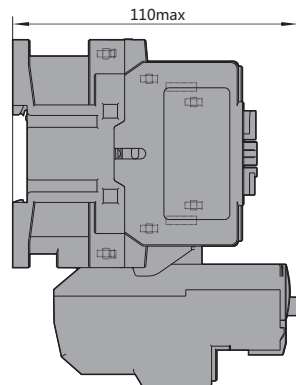
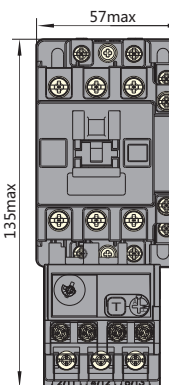

NXR thermal overload relay

NXC-38 + NXR-38

Dimensions and installation

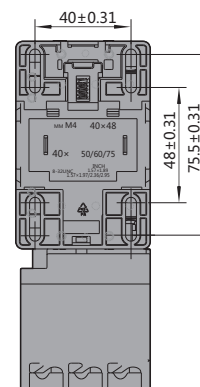
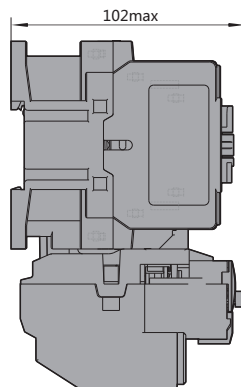
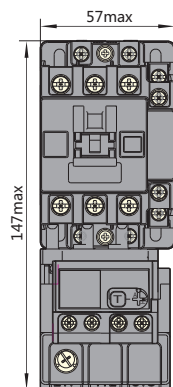

NXC-40 + NXR-100

Dimensions and installation

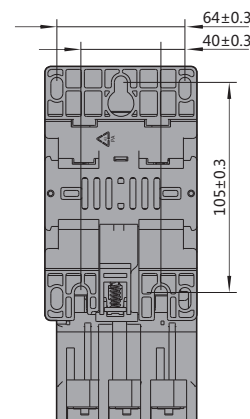
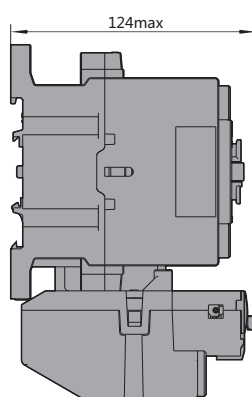
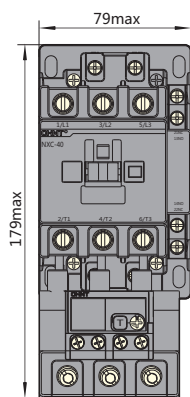

NXC-75 + NXR-100

Dimensions and installation

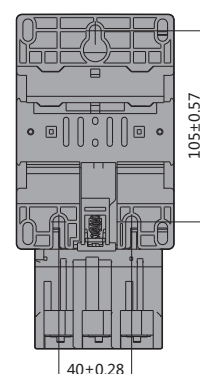
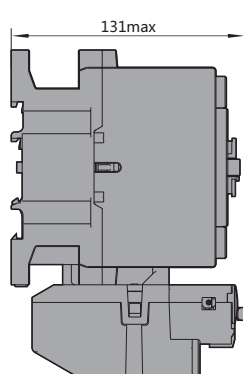
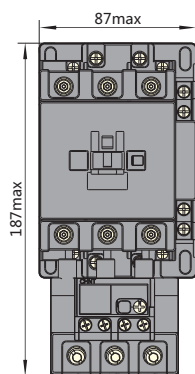

Wiring diagrams

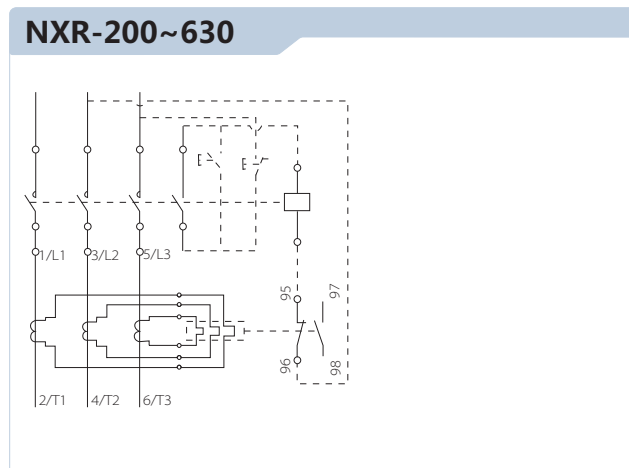
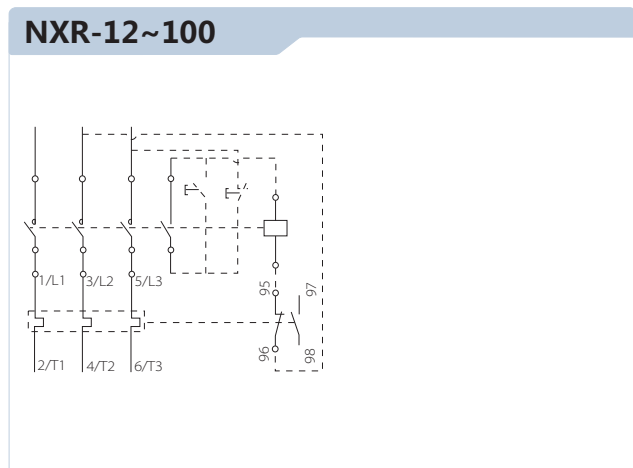

Annex I: Instructions for use in abnormal conditions

- IEC/EN 60947-4-1 standard defines normal operation temperature range for products. Use of products in the normal range will not cause significant impact on their performance.
- At an operation temperature higher than +40°C, the tolerable temperature rise of products needs to be reduced. The rated operation current should be adjusted to prevent product damage, shortened service life, lower reliability, or impact on action characteristics. At a temperature lower than -5°C, impact of changes to the heat dissipation system on the action characteristics of the products should be considered.
- The temperature compensation coefficients at an ambient temperature higher than +40°C and lower than -5°C are given below. The compensation coefficients corresponding to -35°C and +70°C environments are given in the table below. No corrections are required for NXR-200 and NXR-630.

Operation ambient temperature		-35°C	+70°C
Temperature compensation coefficients for NXR-12, 25, 38, 100	Multiple of stable current	1.05	0.9
	Multiple of trip current	1.4	1.2

NXR-12, 25, 38, 100 Temperature compensation curve

