

# VILLAGE OF STOCKBRIDGE NEWSLETTER

Fall/Winter 2017



## CONTACTS AT A GLANCE!

## VILLAGE OFFICE HOURS

### VILLAGE BOARD

Roman Kappus Jr.	Marilyn Behnke
Amy Zahringer	Dean Bornemann
Greg Zickuhr	Tim Lemke
Bruce Rubin	

### CLERK/TREASURER

Lisa Averkamp	439-1700
villageofstockbridge@tds.net	

### WATER/SEWER UTILITY COMMISSION

Roman Kappus Jr.	James Ecker
Dean Bornemann	Bruce Rubin
Chuck Schumacher	Amy Zahringer

### WATER/SEWER UTILITY

Cindy Strebe, Clerk	439-1220
Zach Propson (MCO)	
Bruce Genskow (MCO)	
MCO On Call Number	920-636-8057
villageofstockbridgutilities@gmail.com	

### BUILDING INSPECTOR

Paul Birschbach	378-2857 or 849-9274
binspector@frontier.com	

### ZONING CODE ADMINISTRATOR

Roman Kappus Jr.	841-6867
------------------	----------

### ASSESSOR

Les Ahrens, Grota Appraisals	262-253-1142
LesAhrens@wi-assessor.com	

### GARBAGE & RECYCLING

Advanced Disposal	849-9544 x 104
-------------------	----------------

### LAW ENFORCEMENT

Calumet County Sheriff's Dept.	849-2335
--------------------------------	----------

### SNOW REMOVAL

County & State Roads	
Calumet County Hwy Dept.	849-1434

Village Streets	
J&E Construction	439-1555

**Monday - Thursday 8 a.m. - 3 p.m.**

(closed during lunch hour)

Exceptions due to offsite meetings, election related duties, trainings, illness or vacation will be noted on the front door & voicemail.

If a resident or business owner would require a meeting at another time with the Clerk, outside of these posted hours, please call 439-1700 to schedule and that will always be accommodated.

If you ever need to drop something off for any Village representative, outside regular office hours, there is a secure drop box near the front door. Also, you can leave a voicemail message at 439-1700 and a return call will be made as soon as possible.

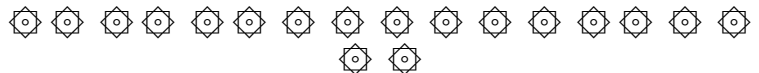

Please note the tax collection hours on Page 3 of this newsletter and please read the entire article for all the information regarding tax collection.

## OVERNIGHT PARKING RESTRICTIONS

Just a friendly reminder that parking citations will be issued on vehicles parked on Village Streets between the hours of 2:30 a.m. - 6:30 a.m.

**November 15<sup>th</sup>  
through March 31<sup>st</sup>**



# CALENDAR OF EVENTS



## **OCTOBER**

### **7<sup>TH</sup> OCTOBERFAST 5K RUN/WALK & KIDS OBSTACLE COURSE**

The Stockbridge Schools PTO group is, once again, organizing a 5K run/walk for the entire family to enjoy. You can sign up at the Stockbridge School office or go to the Stockbridge School PTO Facebook page and complete the sign up form in the link provided.

### **13<sup>TH</sup> – 15<sup>TH</sup> RURAL ARTS ROADTRIP**

Enjoy a weekend in October traveling the scenic roads of Calumet County! Go on the self-guided tour of over 80+ handmade artists representing one of kind arts such as: stained glass, jewelry, handwoven apparel, upcycled furniture, paintings and much more! There are also stops along the way to share in the unique culinary offerings of the East Shores of Lake Winnebago. Check out their website at [www.ruralartsroadtrip.com](http://www.ruralartsroadtrip.com).

### **31<sup>ST</sup> TRICK OR TREATING AND COSTUME CONTEST** sponsored by Stockbridge Fire Department & Stockbridge Lions Club

Stockbridge's tradition is to always hold trick or treating on Halloween! Participating homes should put on porch lights. Ghosts & goblins will be out from 5 – 7, with costume contest at Fire Station to follow.

## **NOVEMBER**

### **11<sup>TH</sup> STOCKBRIDGE SCHOOLS 15<sup>th</sup> ANNUAL CRAFT FAIRE**

Located in the Middle & High School gyms from 9:00 a.m. – 1:00 p.m. Great variety of 80+ arts & crafts vendors! If you are interested in being a vendor, contact Missy at [missybunnell10@gmail.com](mailto:missybunnell10@gmail.com).

## **FEBRUARY**

### **10<sup>TH</sup> OPENING DAY STURGEON SPEARING SEASON**

Participate in this time honored tradition by obtaining your license from the DNR by October 31<sup>st</sup>. If you or someone you know rents shanties for the spearing season on Lake Winnebago and/or the Upriver Lakes, please send the contact information to Ryan Koenigs at [ryan.koenigs@wisconsin.gov](mailto:ryan.koenigs@wisconsin.gov). Shanty rental information is very popular (and helpful) to first-time sturgeon spearkers.

### **20<sup>TH</sup> FEBRUARY PRIMARY ELECTION**

Polling place for the Town & Village of Stockbridge's registered voters is at the Community Hall (attached to the Fire Station) at 175 S. Military Rd. All pertinent election information can be found on the Village website at [www.villageofstockbridge.org](http://www.villageofstockbridge.org).

## **MARCH**

### **3<sup>RD</sup> STURGEON BANQUET**

Join the camaraderie that only the Sturgeon Spearing season can bring to the Lake Winnebago area! Share stories of the season and celebrate with the honorees that speared the largest fish! Great raffle prizes, award ceremony, food & beverages! Tickets will be available at the State Bank of Chilton – Stockbridge location.

## **APRIL**

### **3<sup>RD</sup> SPRING ELECTION**

Polling place for the Town & Village of Stockbridge's registered voters is at the Community Hall (attached to the Fire Station) at 175 S. Military Rd. All pertinent election information can be found on the Village website at [www.villageofstockbridge.org](http://www.villageofstockbridge.org).



# IMPORTANT TAX COLLECTION INFORMATION

The Village office is open for in-person tax collection Mondays - Thursdays 8:00 a.m. – 3:00 p.m. (closed during the lunch hour) from the day the tax bills are mailed from the Calumet County Treasurer until January 31<sup>st</sup>. Any exceptions to these hours due to an outside meeting or illness are always posted on the front door.

Please note that paying your taxes in person is not a requirement. The secure drop box located near the front door of the Village office is always available: 24 hours a day, seven days a week. Any payment deposited in the drop box on or before December 31<sup>st</sup> is entered as a payment made & applied in 2017. Any payments dropped off by January 31<sup>st</sup> are considered a timely payment.

Payments can also be mailed to Village of Stockbridge, PO Box 292, Stockbridge WI 53088. Mailed payments postmarked by December 31<sup>st</sup> will be entered as a payment in 2017. Payments postmarked by January 31<sup>st</sup> are entered as a timely first installment payment. If you require a receipt to reflect your payment date for your accountant or tax preparer, please include a self-addressed, stamped envelope with your payment.

If your bank, mortgage or escrow company forwards your tax payment to the Village, but you'd also like confirmation that the payment has been received, please call to inquire at 439-1700 or email your inquiry to [villageofstockbridge@tds.net](mailto:villageofstockbridge@tds.net).

If you've received an escrow check that is for more than the tax amount, refund checks will be cut & mailed on a bi-monthly schedule.

Also, your **second installment payments** that are due by July 31<sup>st</sup> are due directly to the Calumet County Treasurer at 206 Court St., Chilton WI 53014. The local Treasurer does not process the second installment payments.

The Treasurer will be collecting in person taxes during regular office hours. The office will not be open on Friday, December 29<sup>th</sup>, Saturday, December 30<sup>th</sup> or Sunday, December 31<sup>st</sup>.

You are welcome to leave your payment in the secure drop box and it will be processed as a timely payment on Tuesday, January 2<sup>nd</sup> or if post marked by December 31<sup>st</sup>. The mailing address for the Village of Stockbridge is PO Box 292, Stockbridge WI 53088.

## PROPERTY TAX BREAKOUT (Typical Year Example)

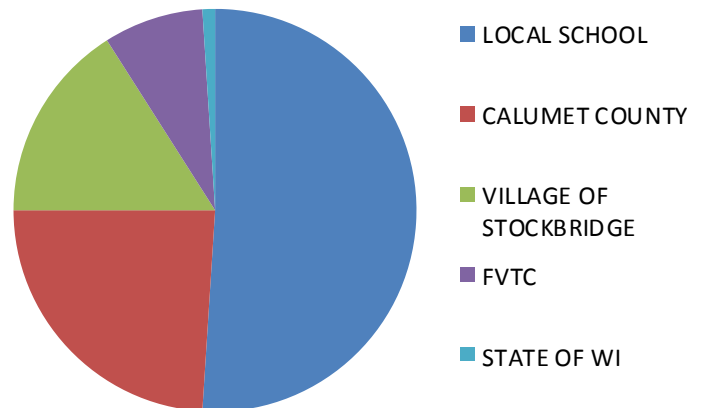

Check out the FAQ tab on the Village website at [www.villageofstockbridge.org](http://www.villageofstockbridge.org).

Great spot to find quick answers to your questions!

# TAX BILL BASICS



The responsibility of the Village's appointed Assessor, Grota Appraisal, is to discover, list, and value uniformly all taxable property in the Village. This work is done to ensure the equitable distribution of the total tax burden within the community. It does not determine the total amount of revenues to be raised.

The tax levy is established by the State, County, local municipality, and school districts, to cover their expenses. The total tax levy is then divided among all owners in proportion to the amount of property they own. These breakdowns are shown on your tax bill.

The local treasurer collects your full payment (if made by January 31st) or your first installment payment. All local municipal treasurers are then responsible for paying out to the other taxing entities (ie...County, State, FVTC & local schools) their proportionate share of the taxes collected by January 31<sup>st</sup>.

All second installment payments are to be paid directly to the Calumet County Treasurer, as indicated on your tax bill.

## VILLAGE BUDGETING & TAX LEVY DETAILS



As mentioned above, your property tax bill consists of money needed by the State of WI, Calumet County, FVTC, local public school and the Village (no, the Village does not keep all the money collected by taxes).

The typical breakout of a tax bill for Village residents will look like this:

- LOCAL SCHOOL DISTRICT: 51% of total tax bill
- CALUMET COUNTY: 24% of total tax bill
- VILLAGE OF STOCKBRIDGE: 16% of total tax bill
- FOX VALLEY TECH: 8% of total tax bill
- STATE OF WI: 1% of total tax bill

So, how does your Village elected officials set the tax levy for the Village? This process starts in September with a budget work session meeting. The current year's expenses and revenues are reviewed during this meeting. There is also a large spreadsheet that the Village Board members review with

approximately (90) different budget line items. These line items are broken down by expenses and receipts. The Board carefully reviews all projects or needs in all areas of budget expenses, including streets, parks, Fire Department, insurance, snow removal, public safety, planning/engineering, community development and more.

These budgetary numbers are also weighed against any changes in expected revenue (keep in mind that the State has cut shared revenue to local municipalities in the past years). Not only have there been cuts in revenue, the State has also imposed levy limits!

What is a levy limit? Well, let's clarify what a levy is first. The tax levy is the amount of money needed, from tax payers, for a municipality to operate. As a simple example, let's look at it this way:

Example: The Village anticipates receiving revenue from the State Shared Revenue program, State road aids, licenses, permits and fees in the amount of \$200,000 but the expenses to run the Village are anticipated to be \$450,000, the difference of \$250,000 is the amount of money (or levy) that the Village will need to ask the tax payers to cover.

The levy limit imposed by the State of Wisconsin is calculated by a worksheet and the Village cannot exceed the levy that the State imposes without a referendum.

At the time this newsletter was printed, the Board was still in their budget process. Updated tax breakouts can be found on the Village's website at [www.villageofstockbridge.org](http://www.villageofstockbridge.org) on the Tax & Assessment tab or can be viewed in person at the Village office or a request for information can be emailed to the Clerk at [villageofstockbridge@tds.net](mailto:villageofstockbridge@tds.net).

Watch for postings on the public posting board, Mud Creek Coffee bulletin board, Post Office bulletin board or on the Village website for all budget work session and budget adoption meeting dates. All meetings are open to the public.



## YARD WASTE SITE NOTICE

When depositing branches at the Yard Waste Site, please do not leave them on the gravel. You are allowed to drive around, on the grass, to the backside of the pile to unload your branches. Thank you for your cooperation!



## SUMP PUMP DISCHARGE

Disconnect sump pump discharges that flow to the street or alley and redirect the flow onto your own property between

**November 1st and April 1st**

This is done to prevent ice buildup on the sidewalks, alley and into the streets which could create a hazard to both motorists and pedestrians.

**No cross connections into the sanitary sewer is permitted per Ordinance – Chapter 32.**

## PLEASE ADOPT A HYDRANT

Please refrain from blowing snow on top of the hydrant near your home or business and keep it free from snow during the winter months.

## VILLAGE WATER & SEWER UTILITIES

The Village Water & Sewer Utility would like to remind all Village of Stockbridge residents that you can now take advantage of two new convenient options for your receiving and paying your monthly utility bills.

1. You can request to have your bills emailed to you. This saves the Utility on the cost of the post cards and postage and ensures your post card doesn't get lost in the mail!
2. You could, alternatively, request that your monthly utility fees be automatically withdrawn from your bank account through the new ACH option!

The forms to request these changes can be found on the Village website at [www.villageofstockbridge.org](http://www.villageofstockbridge.org). Just print off the form, complete and drop off or mail to the Village Office. Or you can also stop into the office to obtain a form or email Cindy at [villageofstockbridgeutilities@gmail.com](mailto:villageofstockbridgeutilities@gmail.com) to request having a form sent to you.

**Questions? Call Cindy at 439-1220**

**FRIENDLY REMINDER:** Please contact Cindy at 439-1220 or email [villageofstockbridgeutilities@gmail.com](mailto:villageofstockbridgeutilities@gmail.com) with your sanitary sewer and water questions and concerns.

## IT WILL BE SNOWMOBILE SEASON SOON!

The Village works with the Calumet Sno Trails club to properly mark trails leading into the Village limits - primarily to gain access for fueling at the gas station and allowing riders an access point and area to park snowmobiles, if they wish to patronize Village businesses.

For as much as we like to promote this winter sport and accommodate a connection for the rider and our businesses, we need to remind all riders that they must also be mindful of all the rules set forth by the trail club, our Village Ordinances 5.01 and Calumet County law enforcement.

**PLEASE STAY ON ALL MARKED TRAILS AND REFRAIN FROM RIDING THE PLOWED SNOW HILL THAT ACCUMULATES ON THE WEST SIDE OF THE GAS STATION!**





## Building & Planning

Before starting any building project, you need to be in compliance with Village, County, State or Federal regulations pertaining to grading, flooding, drainage, water, sewer, zoning, driveways and right-of-ways.

The general application can be found at [www.villageofstockbridge.org](http://www.villageofstockbridge.org) within the FAQ tab. The Clerk, can issue basic permits such as window replacement, fence or roof but if your project entails any structural, electrical or plumbing components, you will need to contact the Building Inspector, Paul Birschbach at 849-9274, to obtain the permit.

Also, depending on the nature of your project, you may also need to have the site plan approved by our Zoning Code Administrator, Roman Kappus, as he is the one that would make sure the size, setbacks etc. comply with our zoning code. His contact information can be found on page one of the newsletter.

Building permits are required for many reasons: To protect you, your family, neighborhood and property values. To ensure that the work performed is safe, that it meets environmental standards and complies with Village zoning and construction codes and to protect your property investment and to minimize liability or problems during a future sale of your property.

**Building Inspector:** If you have any questions regarding building code or inspection requirements notices, please contact Village of Stockbridge Building Inspector Paul Birschbach at 920-849-9274.

**Zoning Administrator:** Questions in regard to zoning or Village ordinances should be directed to the Village Office. A review of your site plan would then be forwarded to the Zoning Code Administrator.

**Assessor:** The Village contracts with Grota Appraisals for assessment services. You may contact Linda Baxter at (262) 253-1142.

**ADVANCED DISPOSAL** offers residents information (below) regarding the makeup of their single stream recycling/garbage trucks. If enough residents are interested in seeing a demonstration on how the trucks work, Advanced Disposal has offered to provide a scheduled street side demonstration. Please contact the Village Clerk with your interest, and a demonstration could then be coordinated.

# Single Stream Recycling Truck

The “Split body truck” we use has two separate compartments, for the two separate commodities. As you can see below in the pictures there is a chute that moves, ensuring the trash goes in one compartment, as the recycling goes into the opposite side. Then we go to the landfill and dump only that side (see picture below). After leaving the landfill with the scale ticket for just the trash tonnage we head over to our recycling center and dump just the recycling side out where it is then sorted and recycled properly.

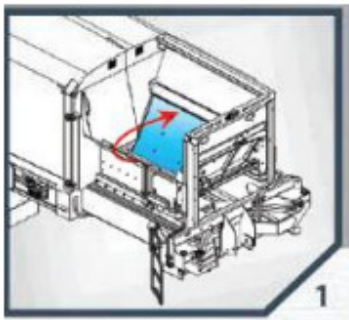

1 With this chute configuration, all the material is dumped into the curbside division of the body.

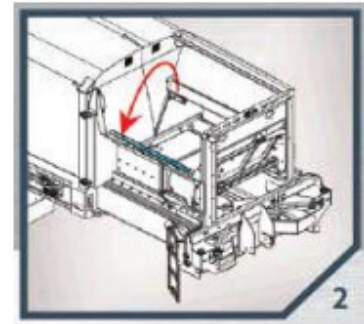

2 Chute in this configuration allows all the material to be dumped in the streetside division of the body.



**NOTE FROM THE VILLAGE PRESIDENT:** I'd like to thank the residents for their patience during this past August road maintenance project on Enterprise, Court and Union Streets. Cooperating with the inconvenience associated with having to park away from your homes, helped ensure a successful road project.

You will notice that the road application was different than the chip-sealing done in years past. This slurry seal application was used to prevent excessive gravel debris from being deposited into our storm sewers. The Village Street Committee will review the durability of this application during the Spring of 2018 to determine if this application will continue to be used.

**Thank you, Roman Kappus, Jr.**

# 2018 GARBAGE & RECYCLING SCHEDULE

<u>MONTH</u>	<u>DATES</u>	<u>EXCEPTIONS</u>	<u>MONTH</u>	<u>DATES</u>	<u>EXCEPTIONS</u>
JANUARY	5, 11, 18, 25	PICK-UP MOVED TO 5 <sup>TH</sup>	JULY	6, 12, 19, 26	PICK-UP MOVED TO 6 <sup>TH</sup>
FEBRUARY	1, 8, 15, 22		AUGUST	2, 9, 16, 23, 30	
MARCH	1, 8, 15, 22, 29		SEPTEMBER	7, 13, 20, 27	PICK-UP MOVED TO 7 <sup>TH</sup>
APRIL	5, 12, 19, 26		OCTOBER	4, 11, 18, 25	
MAY	3, 10, 17, 24		NOVEMBER	1, 8, 15, 23, 29	PICK-UP MOVED TO 23 <sup>RD</sup>
JUNE	1, 7, 14, 21, 28	PICK-UP MOVED TO 1 <sup>ST</sup>	DECEMBER	6, 13, 20, 27	

**VILLAGE GARBAGE & RECYCLING COLLECTION IS ON THURSDAYS, WITH EXCEPTIONS DUE TO HOLIDAYS**

**VILLAGE OF STOCKBRIDGE**  
*“Sturgeon Center of the World”*  
**POST OFFICE BOX 292**  
**STOCKBRIDGE WI 53088-0292**

**RETURN SERVICE REQUESTED**

---

Our newsletter is published two times a year and mailed to all Village of Stockbridge property owners. It is also available on our website at [www.villageofstockbridge.org](http://www.villageofstockbridge.org)

---