

SIDE-TO-SIDE GANGING

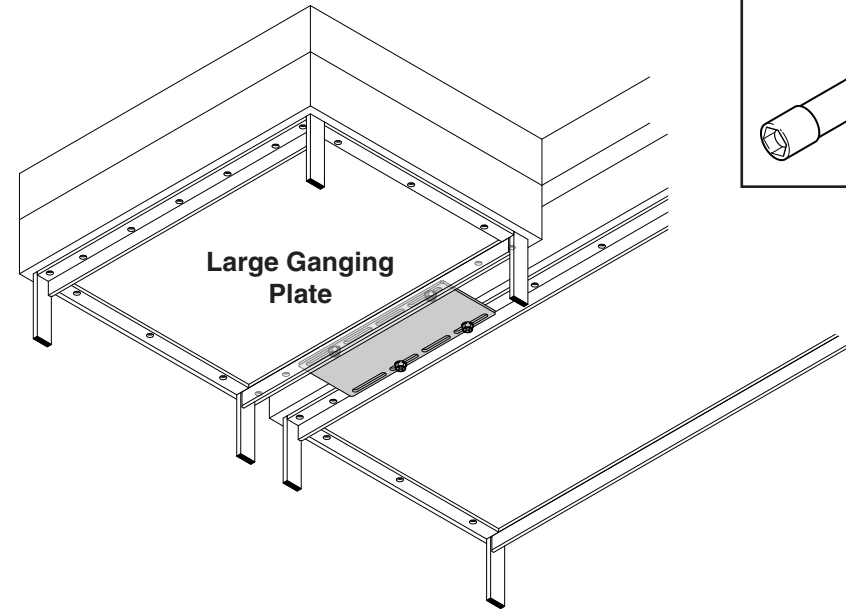

GANGING OFF THE FRONT OF A LOUNGE

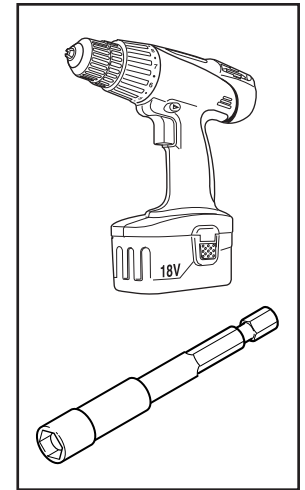

NOTES:

- When ganging off the front of a lounge, use the larger ganging plate because of the cushion overhang.
- All other ganging scenarios (bench to bench, bench to side of lounge, side of lounge to side of lounge) will use the smaller ganging plate.
- When ganging off the side of the lounge, the arm should not be attached. (Lounges can be specified with both arms, one arm, or without arms)

If you have a problem, question, or request, call your local dealer, or Coalesse at 1.800.627.6770 Or visit our website: www.coalesse.com

© 2011 Coalesse
San Francisco, California U.S.A.
Printed in U.S.A.

Side-to-Side Ganging

1. Remove two (2) rear screws that attach the steel base frame on the two products that need to be ganged together.

NOTE: These holes will be used for mounting the ganging plate so make sure the holes used are the same relative location on each product.

2. Attach small ganging plate using screws provided.

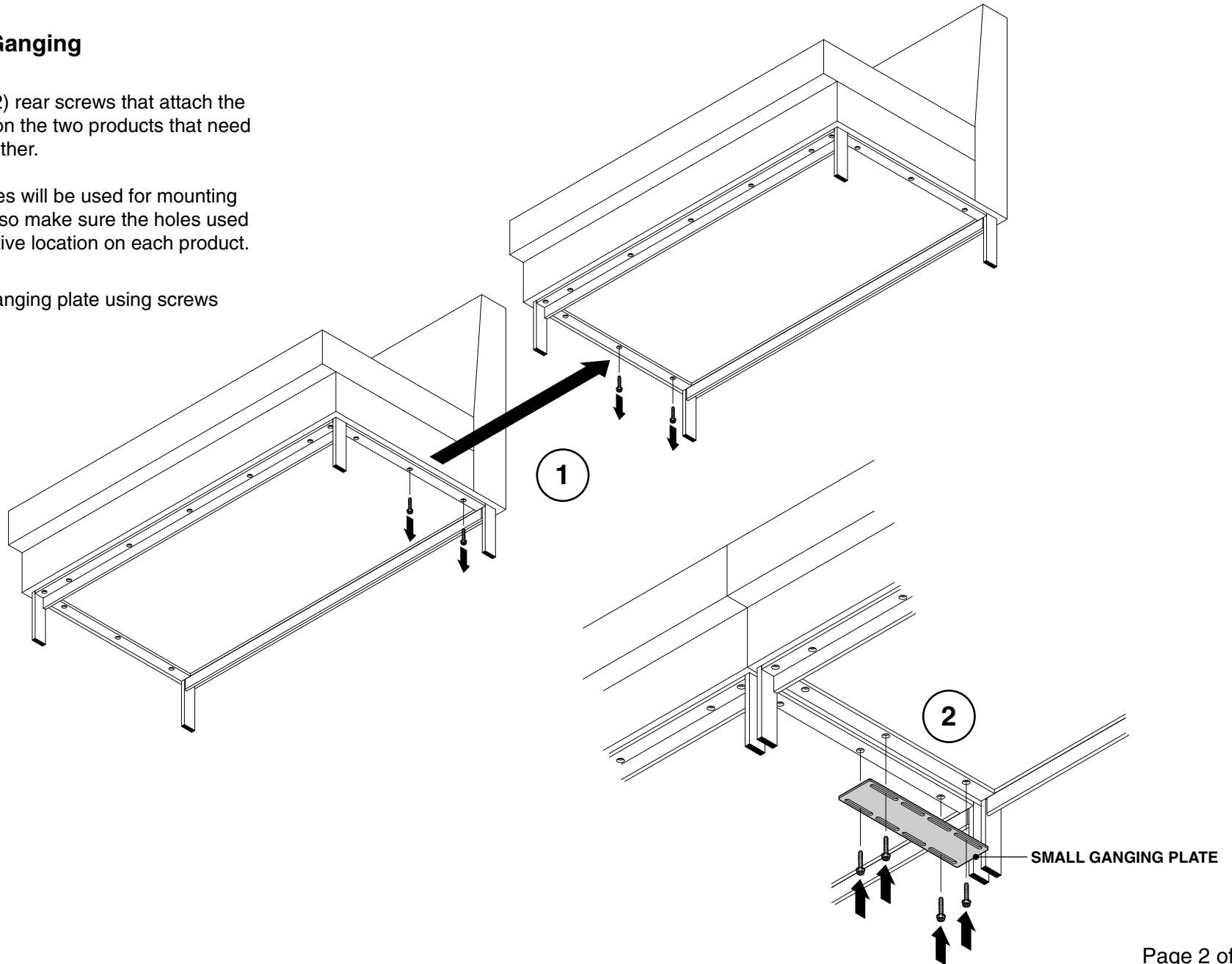

Ganging off the Front of a Lounge

1. Remove two (2) front screws that attach the steel base frame on the two products that need to be ganged together.

NOTE: These holes will be used for mounting the ganging plate so make sure the holes used are the same relative location on each product.

2. Attach large ganging plate using screws provided.

