

Coped work surface profiles provide a smooth transition between tops.

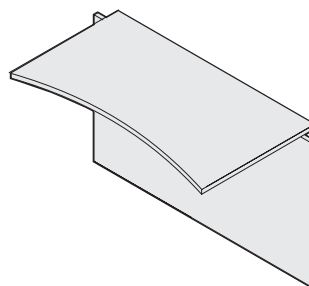

Curved Front Bridge

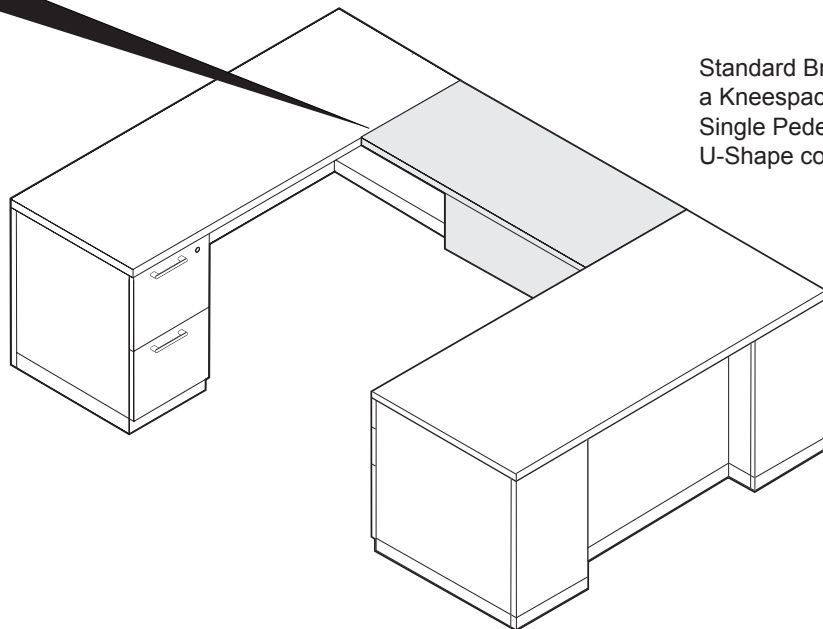

Standard Bridge attached to a Kneespace Credenza and a Single Pedestal Desk form a U-Shape configuration.

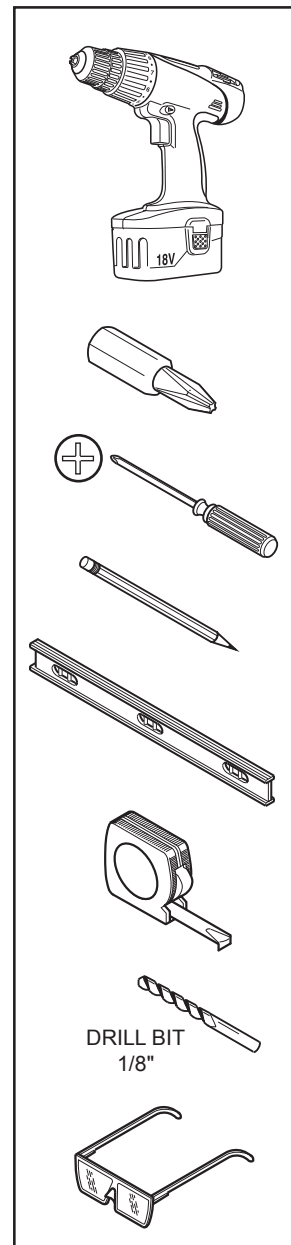

If you have a problem, question, or request, call your local dealer, or Steelcase Line 1 at 888.STEELCASE (888.783.3522) for immediate action by people who want to help you. (Outside the U.S.A., Canada, Mexico, Puerto Rico, and the U.S. Virgin Islands, call: 1.616.247.2500) Or visit our website: www.steelcase.com
© 2006 Steelcase Inc.
Grand Rapids, MI 49501
U.S.A.
Printed in U.S.A.

1. Insert (3) connecting bolts into the holes on the bridge worksurface as shown.

2. Align modesty panel with bridge worksurface (2a). As modesty panel is lowered, make sure holes align with connecting bolts on bridge worksurface (2b).

3. Insert (3) camlocks into holes in the modesty panel (3a), making sure the arrow on cam locks are pointing toward the connecting bolts (3b). Secure with a quarter turn.

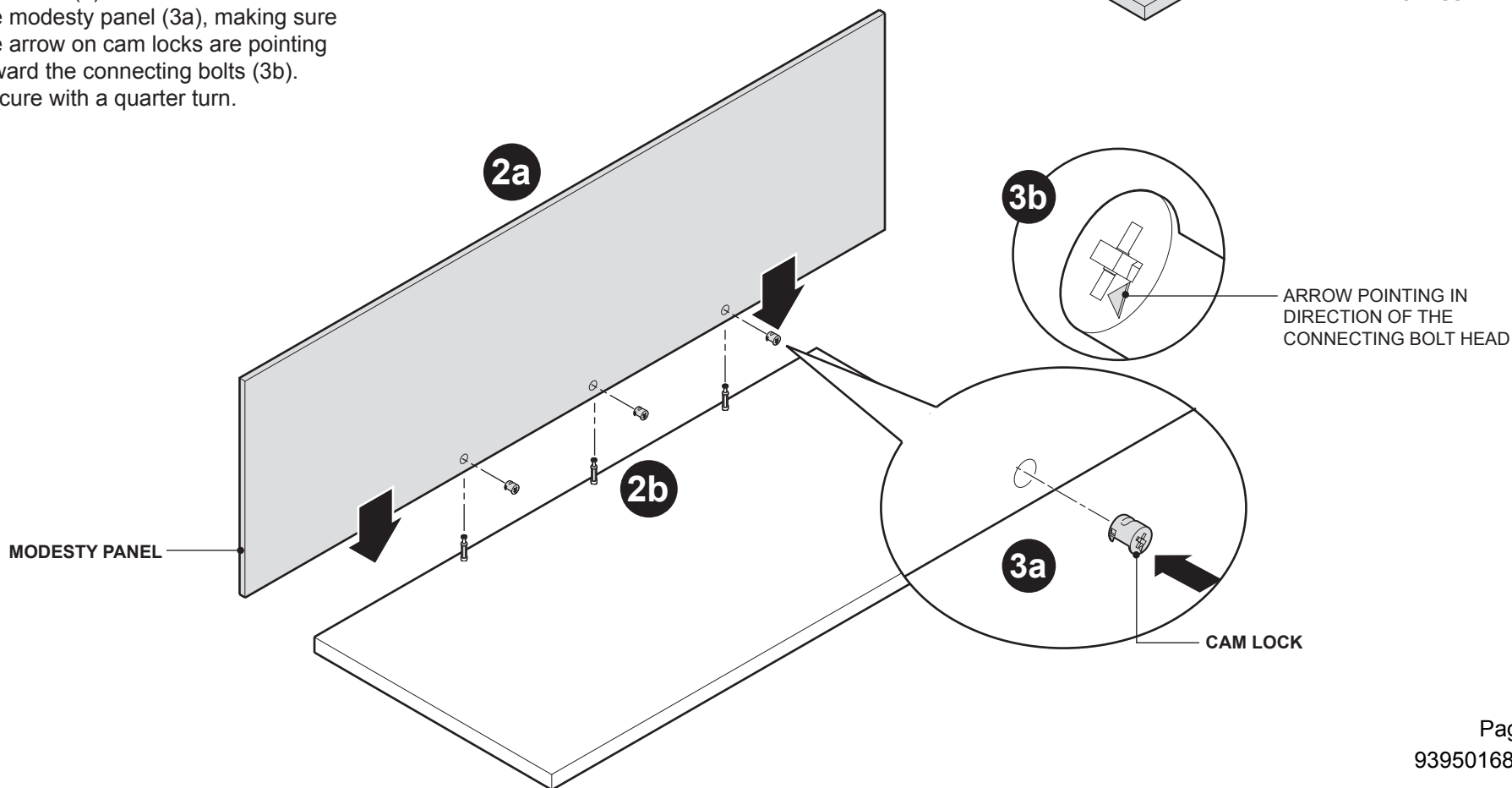
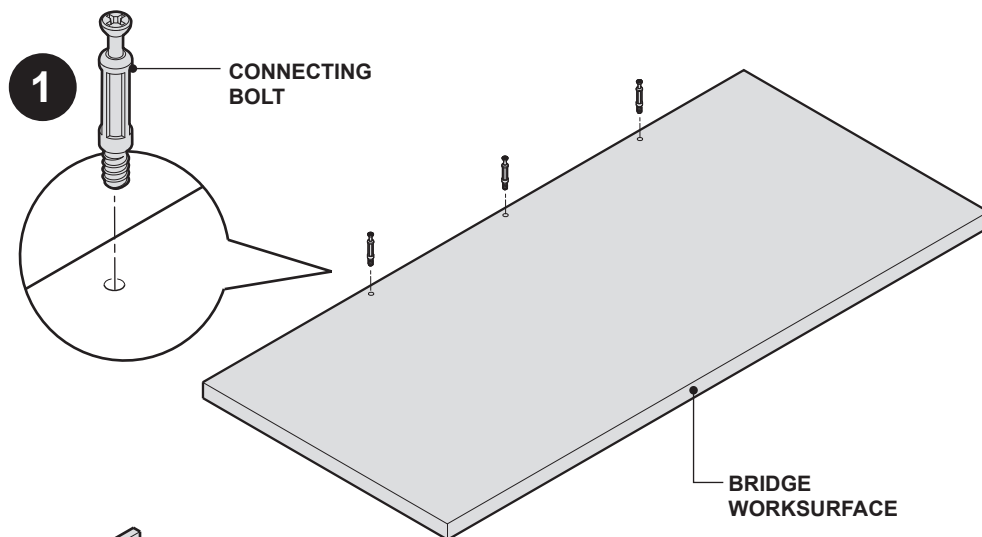

4. Install a pair of mounting brackets onto the underside of tops of adjoining units. Position brackets (4a), drill pilot holes (4b), then secure with screws provided (4c).

Note: at delivery, the mounting brackets may be found attached to the bottom of the worksurface for ease of shipping.

5. Move adjoining units into approximate positions.

6. Put bridge assembly into place so that it rests on brackets.

7. Secure bridge top to brackets (5) screws each side.

8. Secure bridge back panel to adjacent end panels.

9. Level units as needed.

