



- TETHER RETROFIT KIT CONSISTS OF:**
-  TETHER
 -  5/16-18 x 3/8" SELF TAPPING SCREW
 -  #8-18 x 1/2" SELF DRILLING SCREW

1. Drill a 1/8" diameter hole at the location shown (1a). Using a #8-18 x 1/2" self drilling screw, secure the tether to the top of any 90°, 120°, 135° and specifiable angle junction cover (1b).

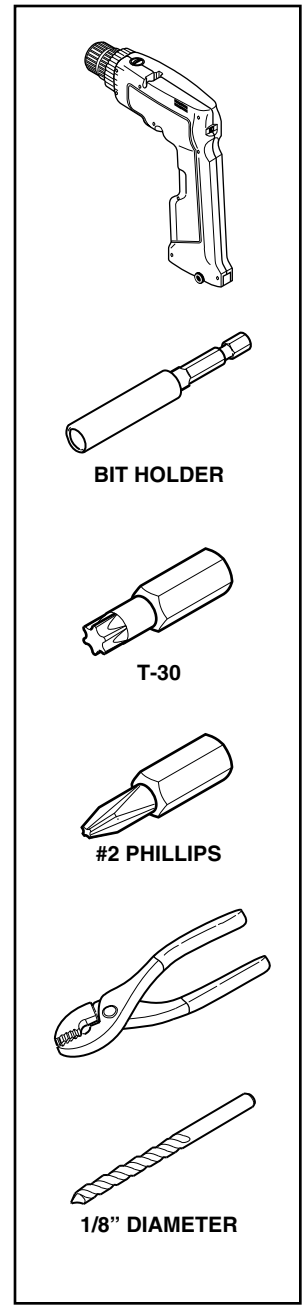
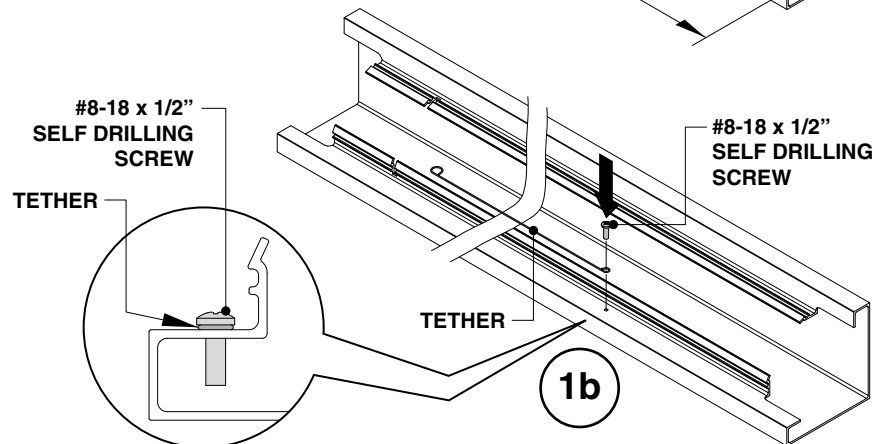
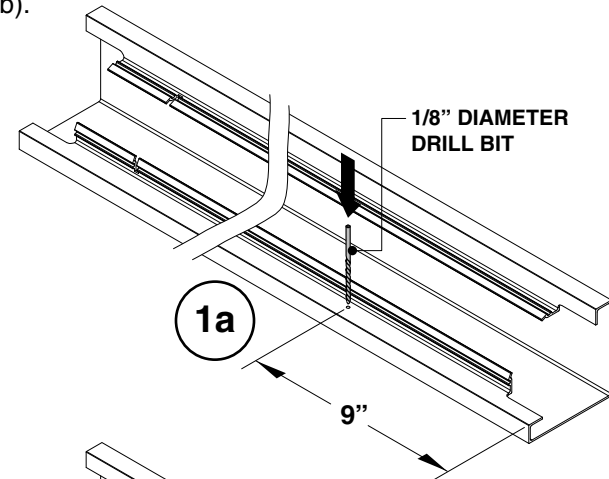

If you have a problem, question, or request, call your local dealer, or Steelcase Line 1 at **888.STEELCASE** (888.783.3522) for immediate action by people who want to help you.

(Outside the U.S.A., Canada, Mexico, Puerto Rico, and the U.S. Virgin Islands, call: 1.616.247.2500) Or visit our website: www.steelcase.com

© 2014 Steelcase Inc.
Grand Rapids, MI 49501
U.S.A.

Printed in U.S.A.

2. Attach tether to vertical post of corner junction using 5/16-18 x 3/8" self tapping screw as shown.

3. Assemble junction cover per assembly direction 939502319 - page 4.

TIP: If a junction cover appears to fit loosely and to prevent junction cover dislodgement, especially next to doors, use a pair of pliers to flair the flanges outward a bit to increase the fit between flange and junction blocks. This only needs to be done where the junction cover meets the junction blocks.

