

Campfire™ Skate Table

turnstone®

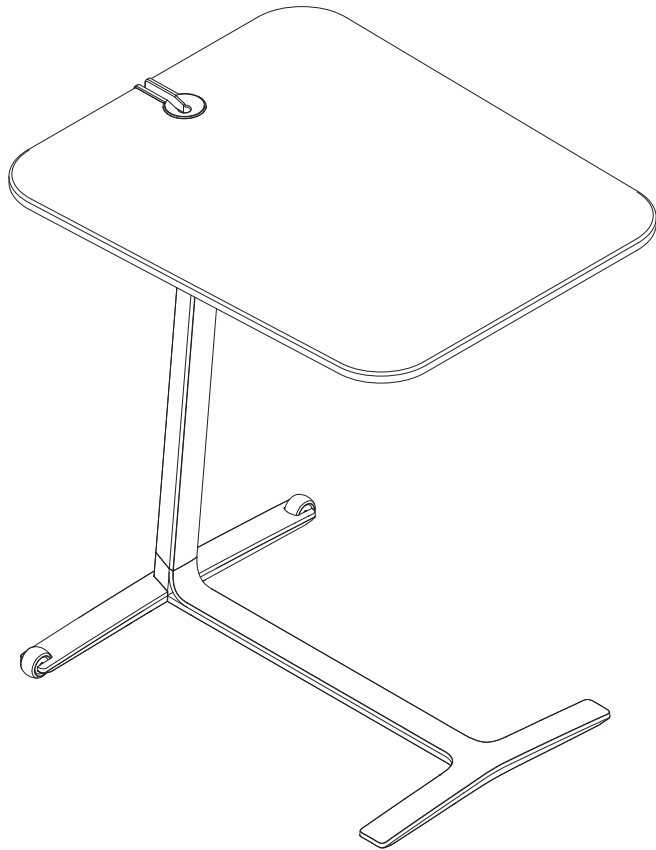

1. Place top assembly upside down on a clean, scratch resistant surface. Install threaded rod into the top bracket, and hand tighten.

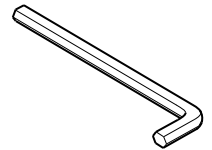
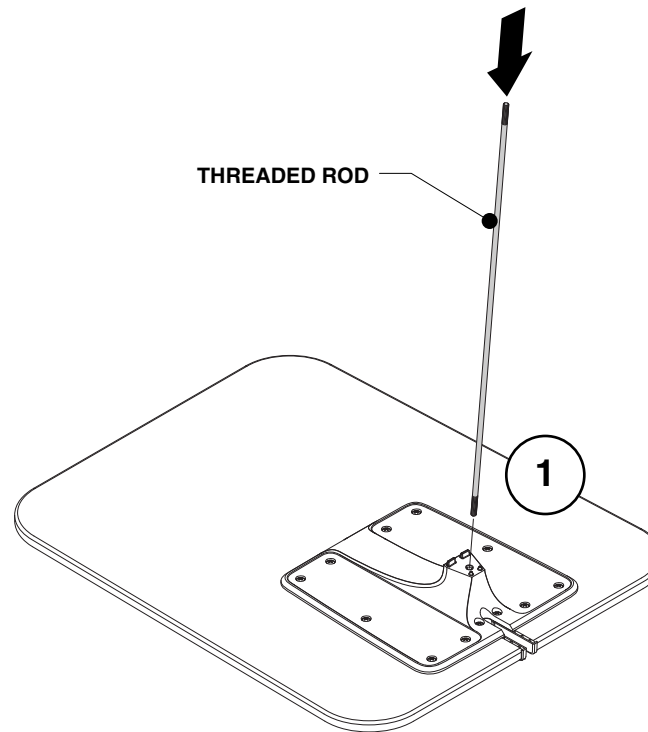

5MM HEX WRENCH
(PROVIDED)

2. Place the leg extrusion over the threaded rod (2a) and insert into the round & rectangular locating detents on the top bracket (2b).

3. Place the base assembly onto the threaded rod & leg extension with locating detents on the base assembly (same as step 2b). Secure with tooth washer and nut. Torque nut to 50 in*lbs.

WARNING: Do not twist leg extrusion or base assembly during assembly.

