

If you have a problem, question, or request, call your local dealer, or Steelcase Line 1 at **888.STEELCASE** (888.783.3522) for immediate action by people who want to help you. (Outside the U.S.A., Canada, Mexico, Puerto Rico, and the U.S. Virgin Islands, call: 1.616.247.2500) Or visit our website: www.steelcase.com

© 2010 Steelcase Inc.
Grand Rapids, MI 49501
U.S.A.

Printed in U.S.A.

Seat Replacement

1. Place plastic seat bottom side up on a covered or protected worksurface.
2. Set chair frame on plastic seat so that the front wire is captured by the lip on the front of the plastic seat. The six bosses on bottom of seat must project thru the holes in the side plates of the seat frame.
3. Using a standard 1/2" socket and spinner handle, drive internal tooth lock washer over bosses to rest securely against side plates.

NOTE: It is important that very firm pressure be applied at each boss to force the plastic and steel bracket tightly together at the time the washers are being driven onto the plastic bosses.

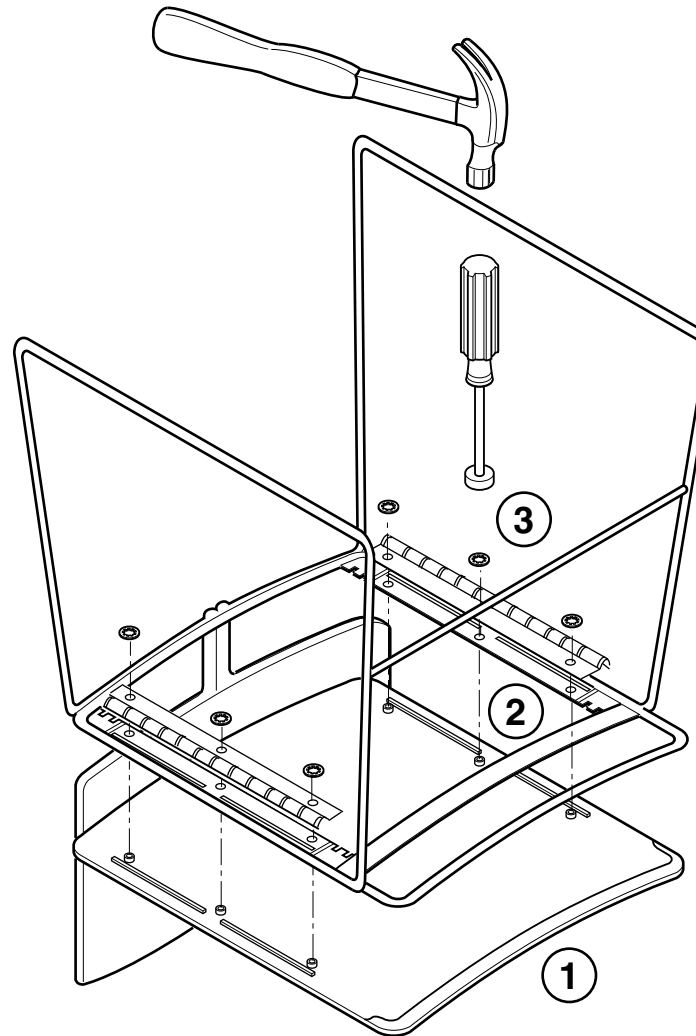

Back Replacement (For Chairs Built After June 18, 1994)

1. Remove screw.
2. Remove old chair back.
3. Replace with new chair back.
4. Secure with screw (Torque to 25 ± 5 in/lbs).

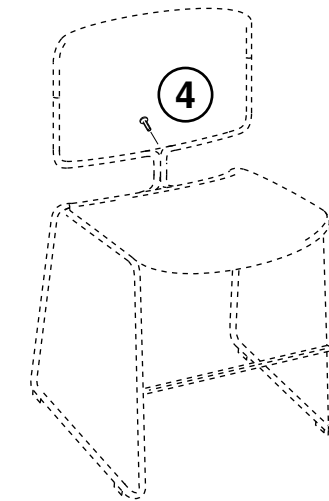
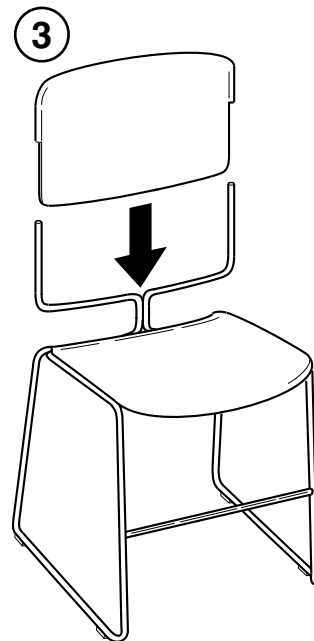
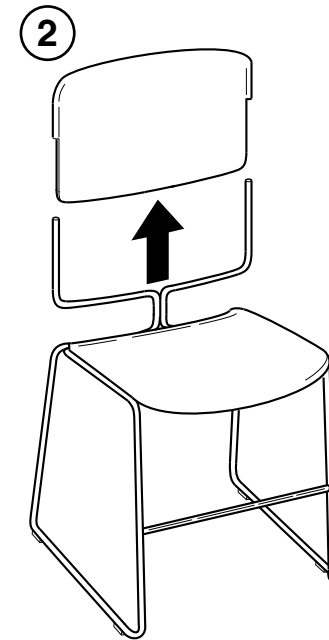
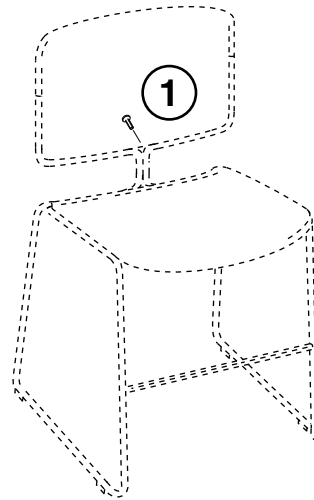

Back Replacement (For Chairs Built Before June 18, 1994)

1. Remove screws.
2. Remove old chair back.
3. Replace with new chair back.
4. Secure with screws (Torque to 4-18 in/lbs).

