

# ASSEMBLY INSTRUCTIONS MANUAL DE MONTAGEM / INSTRUCCIONES DE ARMADO

WALL CABINET 3 DOORS  
AEREO 3P  
ARMARIO DE PAREDE 3 PUERTAS

Reference  
Referência  
Referencia **250484** | Revise  
| Revisão  
| Revisión **00**

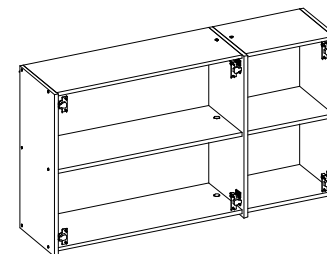

**YOU WILL NEED  
VOCÊ VAI PRECISAR DE / USTED NECESITARÁ**

Tools not supplied  
Ferramentas não fornecidas / Herramientas no incluidas

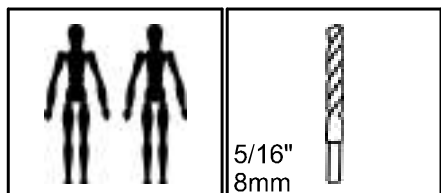

2 People  
2 Pessoas  
2 Personas

Drill bit  
Broca  
Taladro

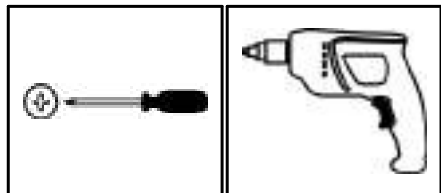

Screwdriver Phillips  
Chave Phillips  
Destornillador cruz

Drill machine  
Furadeira  
Taladro

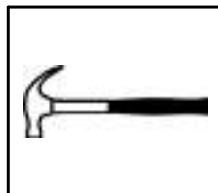

Hammer  
Martelo  
Martillo

**MAXIMUM RECOMMENDED WEIGHT  
BEING THIS EVENLY DISTRIBUTED.**  
**PESO MÁXIMO RECOMENDADO SENDO  
ESTE DISTRIBUÍDO UNIFORMEMENTE.**  
**PESO MÁXIMO RECOMENDADO SIENDO  
ESTE UNIFORMEMENTE DISTRIBUIDO.**

	LB	KG
D	11	5
F	22	10

**PARTS IDENTIFICATION  
IDENTIFICAÇÃO DAS PEÇAS / IDENTIFICACIÓN DE LAS PIEZAS**

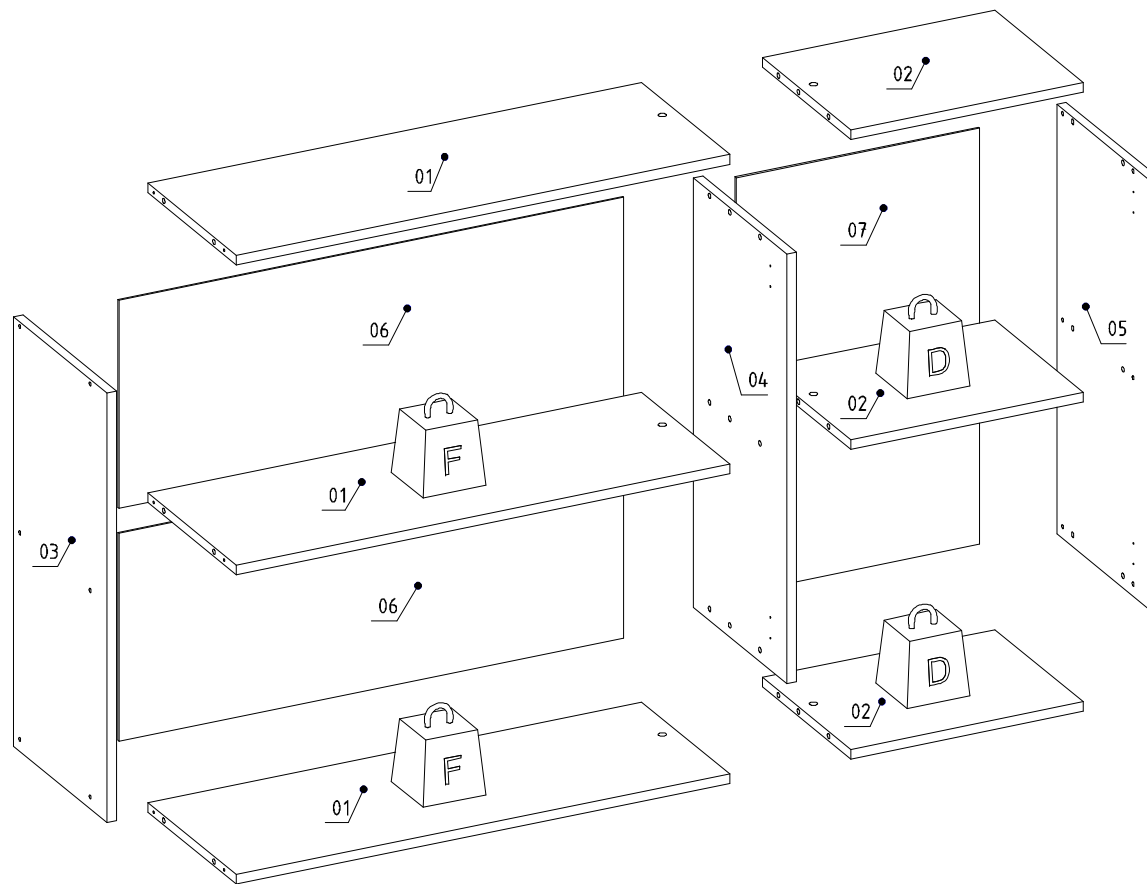

Nº	Measures_Inches	Medidas_cm	Qty./Qtd.
01	30 7/8 x 11 1/8 x 5/8	78.5 x 28.1 x 1.5	3
02	14 5/8 x 11 1/8 x 5/8	37.0 x 28.1 x 1.5	3
03	26 3/8 x 11 3/4 x 5/8	67.0 x 29.7 x 1.5	1
04	26 3/8 x 11 3/4 x 5/8	67.0 x 29.7 x 1.5	1
05	26 3/8 x 11 3/4 x 5/8	67.0 x 29.7 x 1.5	1
06	31 5/8 x 12 3/4 x 1/8	80.3 x 32.4 x 0.3	2
07	25 1/2 x 15 1/4 x 1/8	64.9 x 38.7 x 0.3	1

03

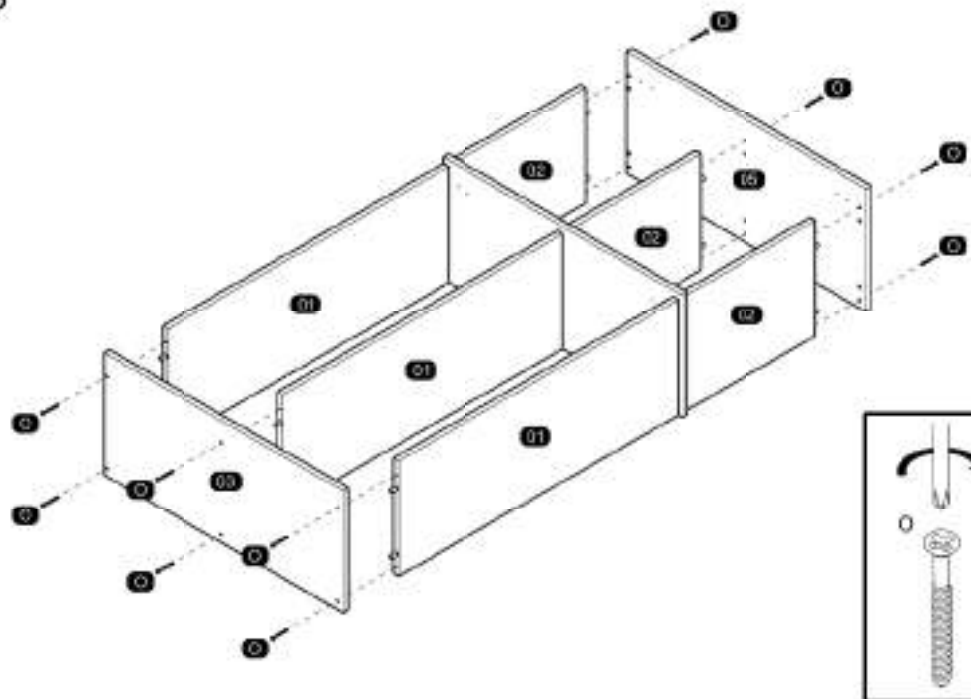

05

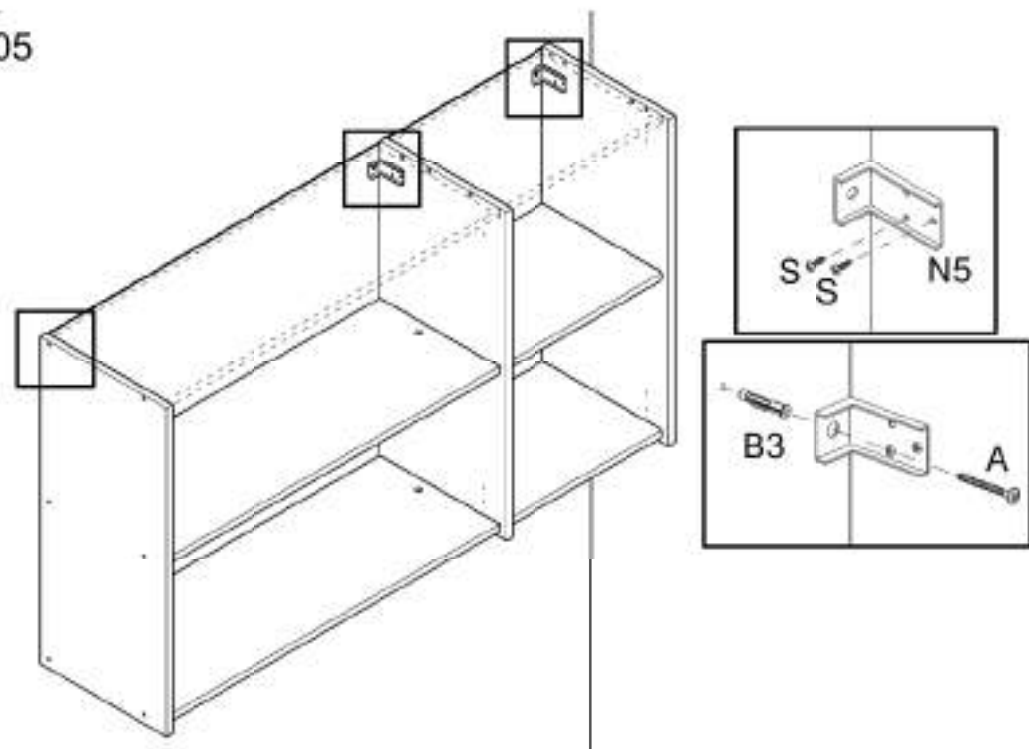

04

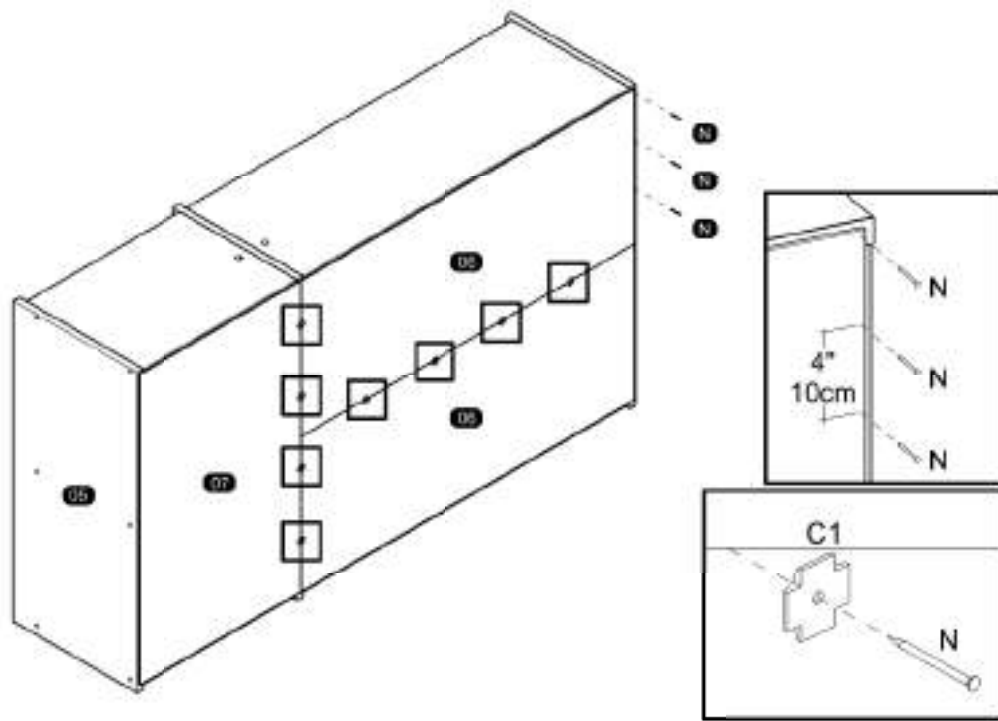

06

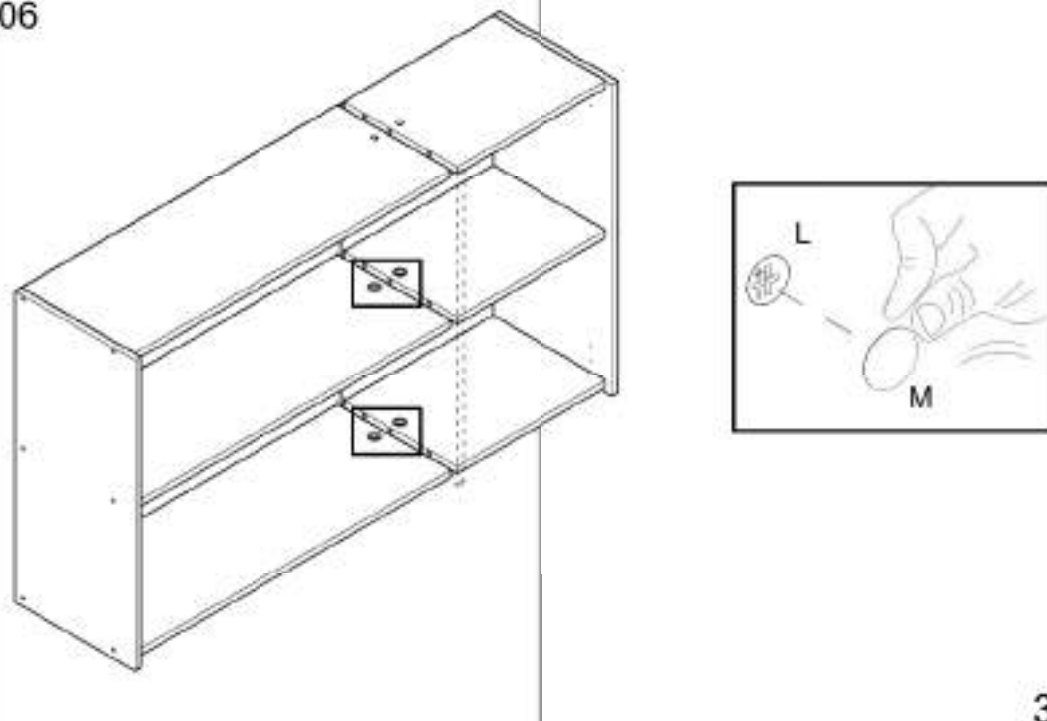

**MOUNTING ON THE CHOSEN DOOR MODEL**  
**MONTAGEM NO MODELO DE PORTA ESCOLHIDO / MONTAJE EN EL MODELO DE PUERTA ELEGIDO**

07

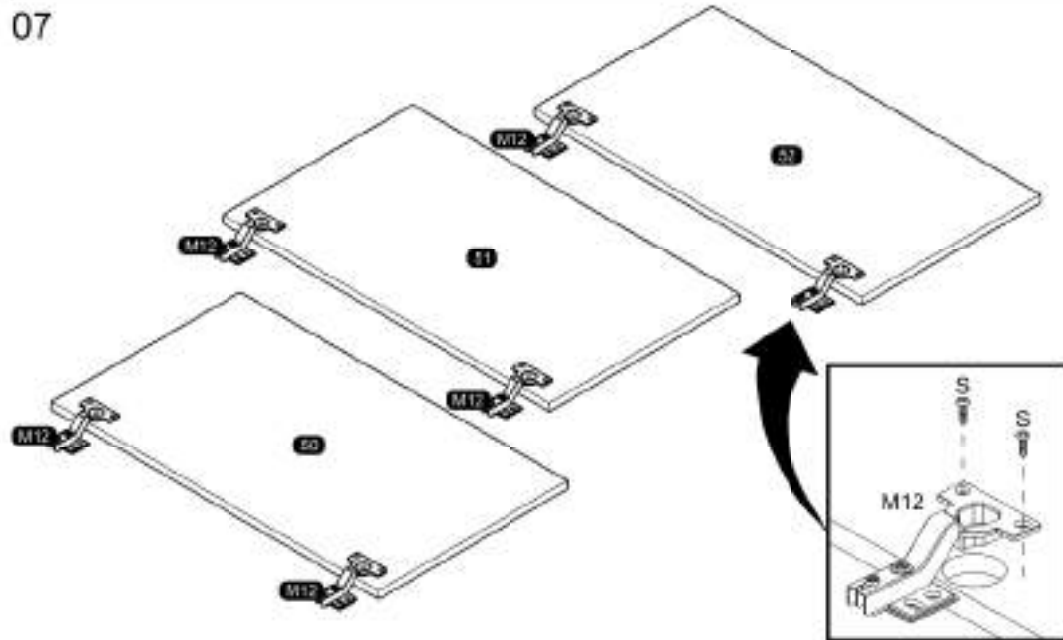

09

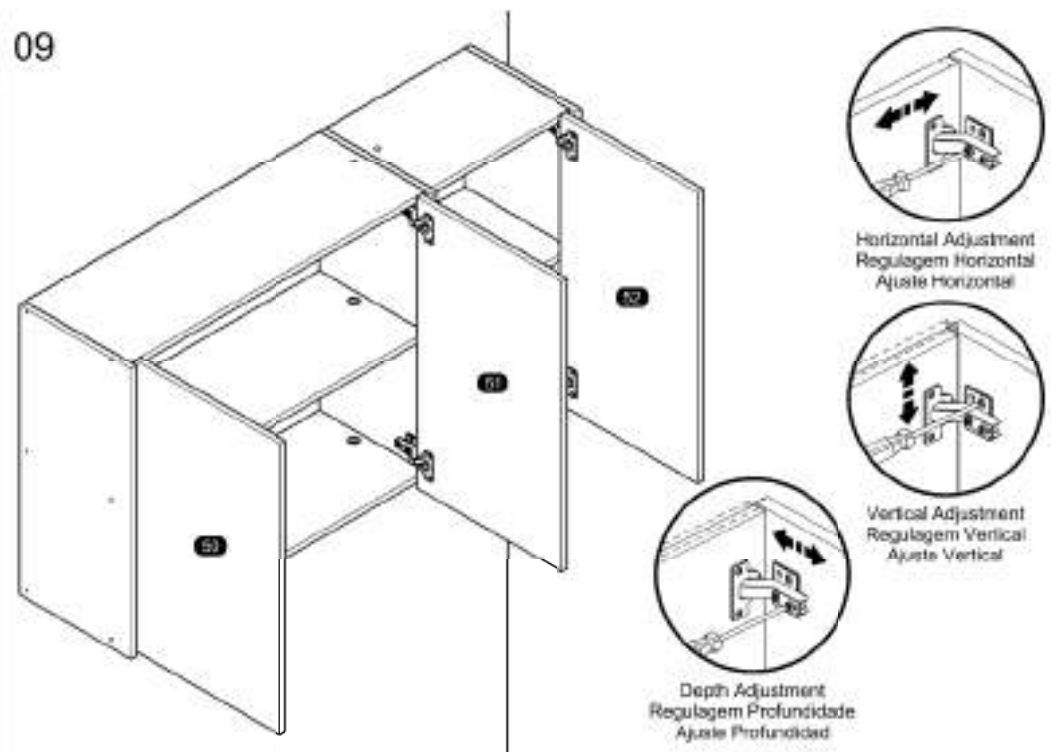

08

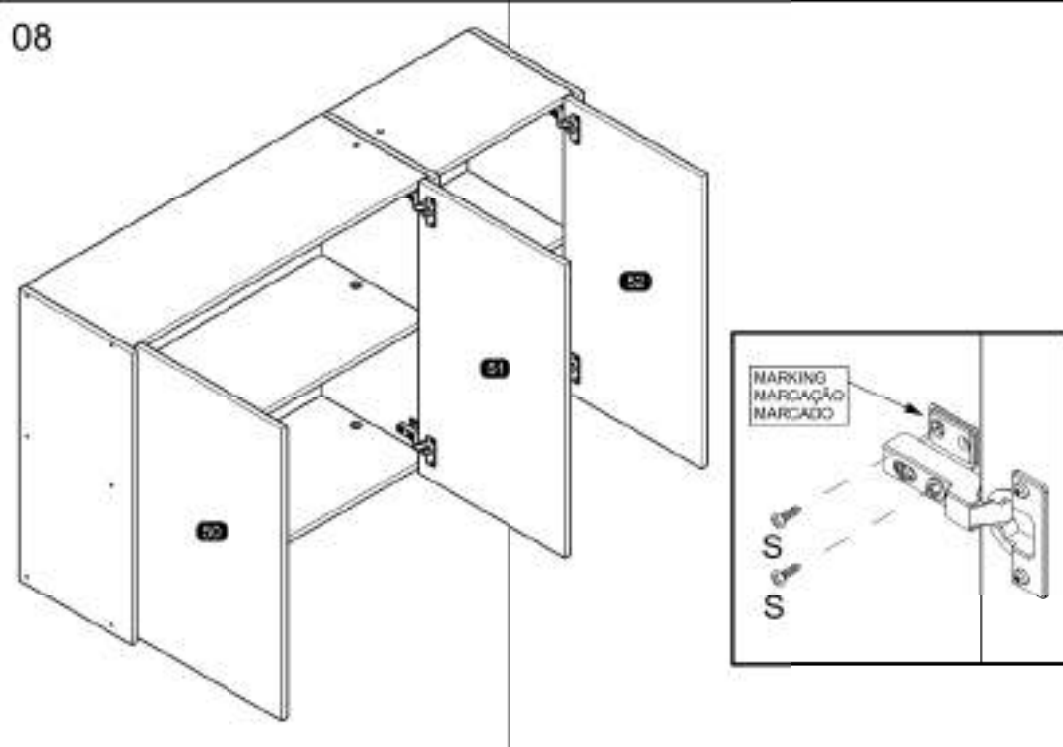

10

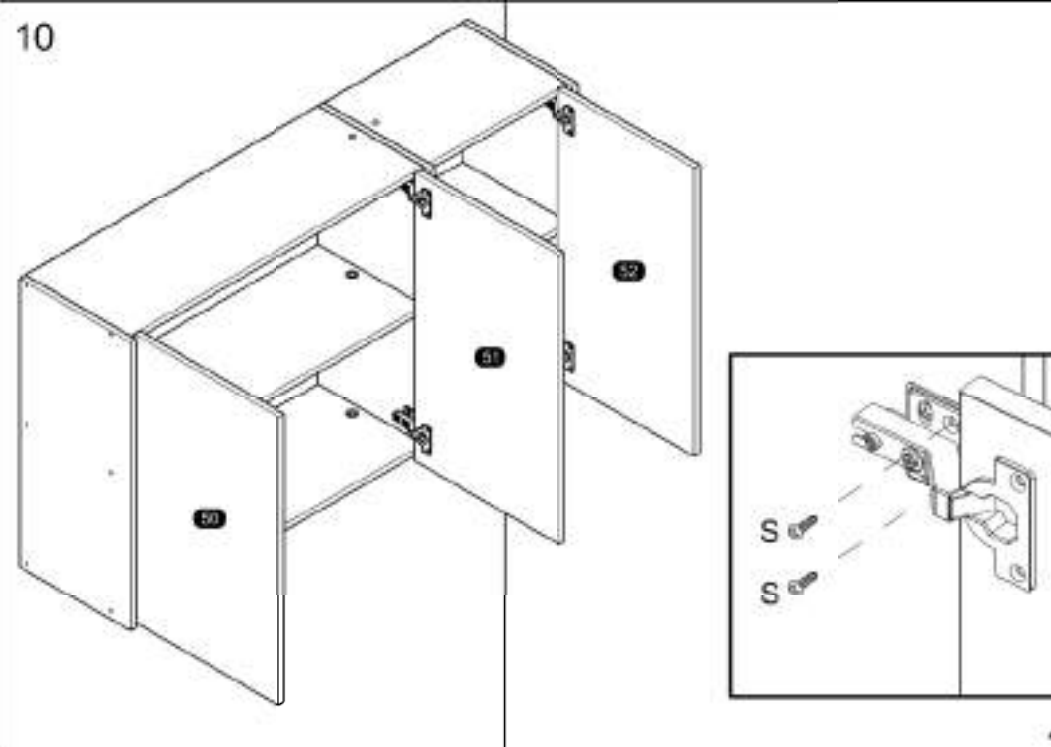

# ASSEMBLY INSTRUCTIONS MANUAL DE MONTAGEM / INSTRUCCIONES DE ARMADO

WALL CABINET 1 FLAP DOOR / 2 SMALLER DOORS

ARMARIO AEREO 1PB / 2P MENOR

ARMARIO DE PARED 1 PUERTA HORIZONTAL / 2 PUERTAS PEQUEÑAS

Reference | Revise  
Referência | Revisão  
Referencia | Revisión

## 250485

## 00

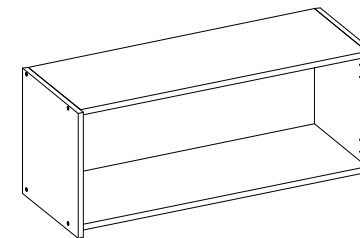

### YOU WILL NEED VOCÊ VAI PRECISAR DE / USTED NECESITARÁ

Tools not supplied  
Ferramentas não fornecidas / Herramientas no incluidas

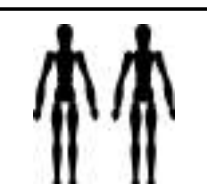

2 People  
2 Pessoas  
2 Personas

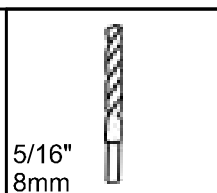

Drill bit  
Broca  
Taladro

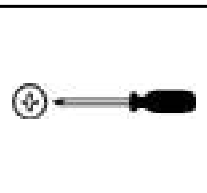

Screwdriver Phillips  
Chave Phillips  
Destornillador cruz



Drill machine  
Furadeira  
Taladro

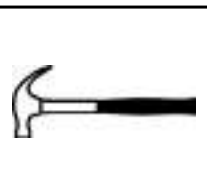

Hammer  
Martelo  
Martillo

MAXIMUM RECOMMENDED WEIGHT BEING THIS EVENLY DISTRIBUTED.  
PESO MÁXIMO RECOMENDADO SENDO ESTE DISTRIBUÍDO UNIFORMEMENTE.  
PESO MÁXIMO RECOMENDADO SIENDO ESTE UNIFORMEMENTE DISTRIBUIDO.

	LB	KG
E	17	8

### PARTS IDENTIFICATION IDENTIFICAÇÃO DAS PEÇAS / IDENTIFICACIÓN DE LAS PIEZAS

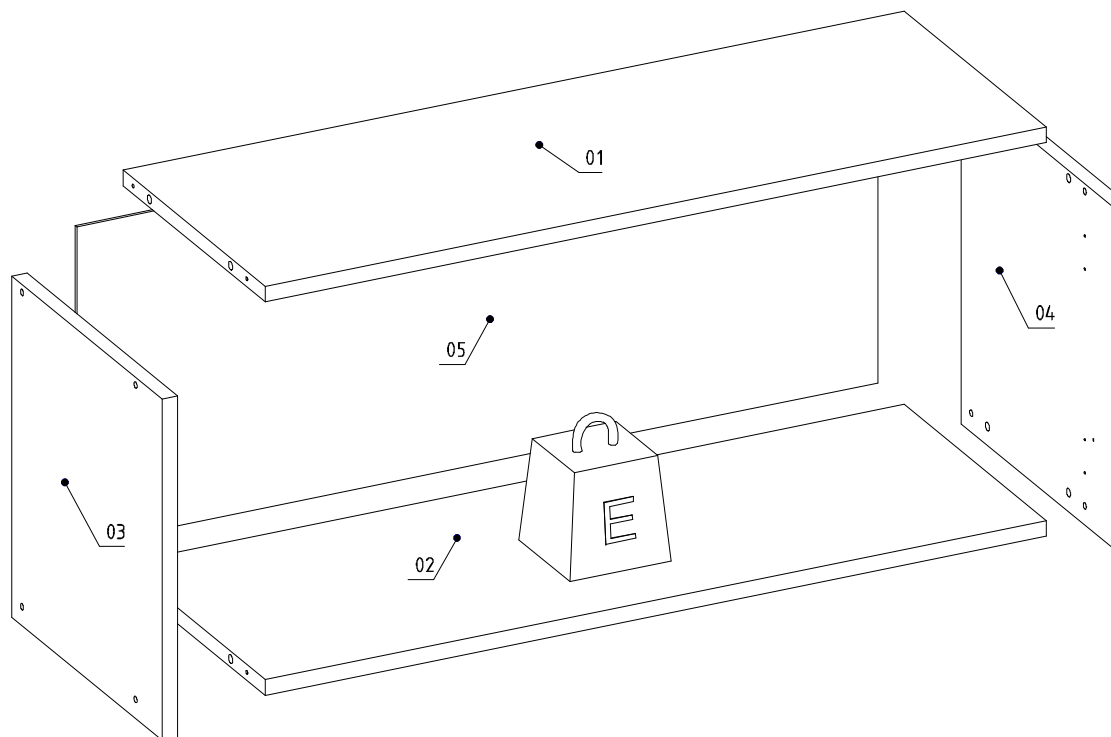

Nº	Measures_Inches	Medidas_cm	Qty./Qtd.
01	30 3/8 x 11 1/8 x 5/8	77.0 x 28.1 x 1.5	1
02	30 3/8 x 11 1/8 x 5/8	77.0 x 28.1 x 1.5	1
03	13 x 11 3/4 x 5/8	33.0 x 29.7 x 1.5	1
04	13 x 11 3/4 x 5/8	33.0 x 29.7 x 1.5	1
05	31 1/8 x 12 1/8 x 1/8	79.0 x 30.9 x 0.3	1

## IDENTIFICATION OF ACCESSORIES IDENTIFICAÇÃO DOS ACESSÓRIOS/ IDENTIFICACIÓN DE ACCESORIOS



The separation of the accessories before you start the assembly will facilitate the same. In case of doubt on the size of the screws and bolts, use the ruler at bottom of page.  
A separação dos acessórios antes de iniciar a montagem facilitará a mesma. Em caso de dúvida no tamanho dos parafusos e cavilhas, utilize a régua ao final da página.  
La separación de los accesorios antes de comenzar el armado facilitará el mismo. En caso de duda sobre el tamaño de los tornillos y taquetes, utilice la regla al pie de página.

A		Flanged head screw Parafuso flangeado / Tornillo de cabeza flangeada	5,0x90 mm	2
B3		Bushing Buchsa expansiva / Tapón	8x50 mm	2
E		Wooden dowel Cavilha / Taquete	8x30 mm	8
N		Nail Prego / Clavo	10x10	20
N5		Support "L" Soporte "L" / Soporte "L"	-	2
O		Flat head screw Parafuso aboto / Tornillo de cabeza plana	4,5x45 mm	8
S		Pan head screw Parafuso panela / Tornillo de pan	3,5x14 mm	16
S7A		Gas piston Pistão a gás / Pistón de gas	-	1
S7B		Side support piston Suporte pistão lateral / Soporte pistón lateral	-	1
S7C		Door support piston Suporte pistão porta / Soporte pistón puerta	-	1
S7D		Pan head screw Parafuso panela / Tornillo de pan	3,5x12 mm	5
Z13		Metal hinge straight Dobradiça reta / Bisagra recta	35 mm	2



### ATENÇÃO!

For hinged doors, the (M12) accessory and (S) fixing screws are supplied in the door package

Na configuração com portas de giro, o acessório (M12) e os demais parafusos de fixação (S) acompanham o produto no volume das portas

Para puertas batientes, el accesorio (M12) y los tornillos de fijación (S) se suministran en el bulto de las Puertas.

M12		Metal hinge super high Dobradiça super alta / Bisagra alta	35 mm	4
S		Pan head screw Parafuso panela / Tornillo de pan	3,5x14 mm	24



## PRE-ASSEMBLE PRÉ-MONTAGEM / PRE ARMADO

01

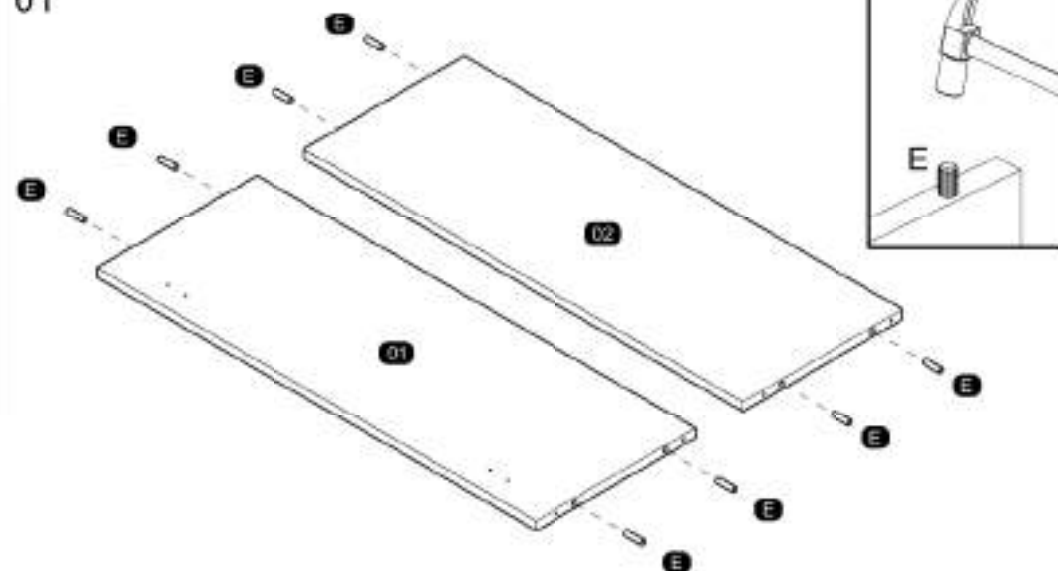

## ASSEMBLY MONTAGEM / ARMADO

02

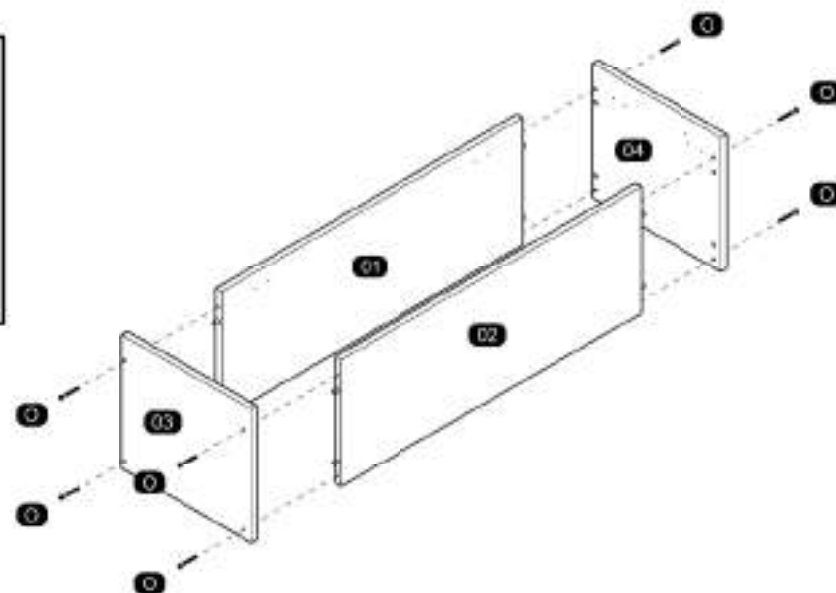
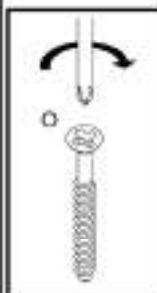

03

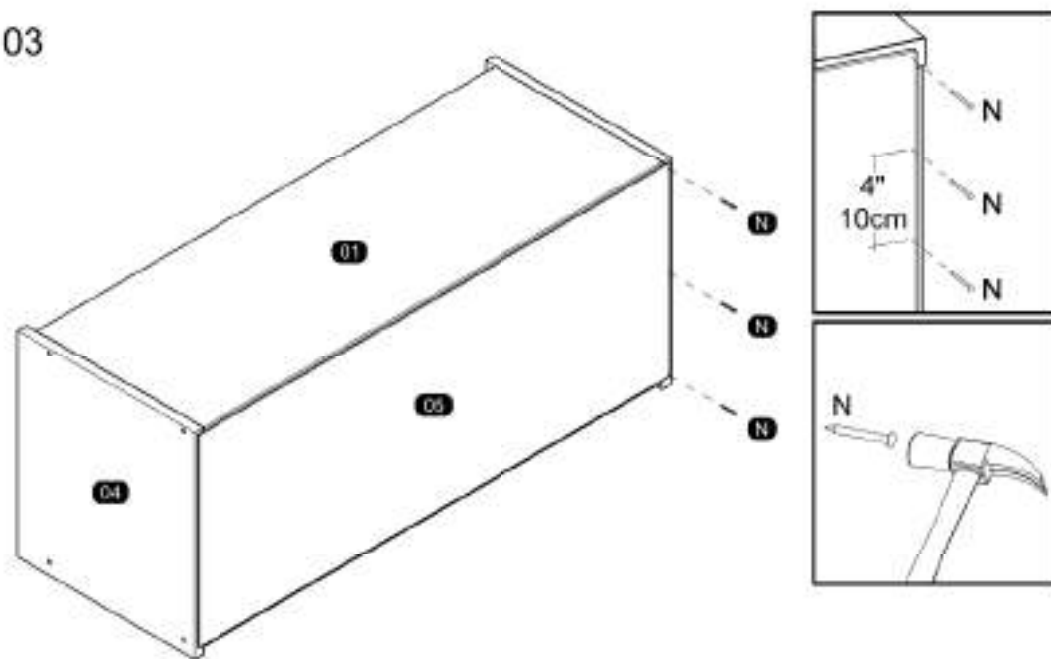

MOUNTING ON THE CHOSEN DOOR MODEL  
 MONTAGEM NO MODELO DE PORTA ESCOLHIDO / MONTAJE EN EL MODELO DE PUERTA ELEGIDO

05

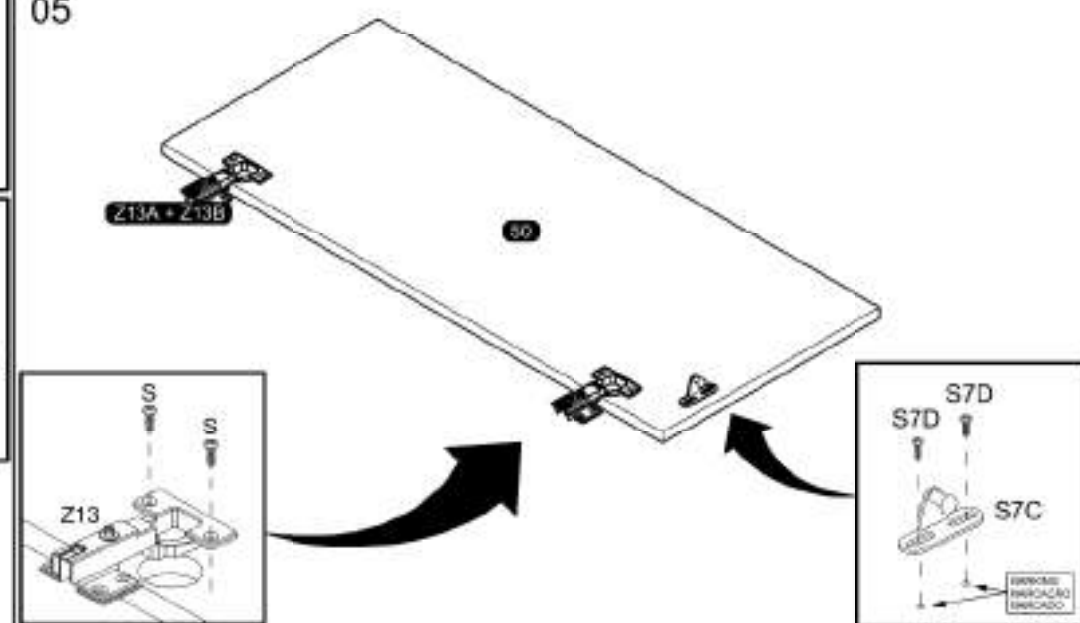

04

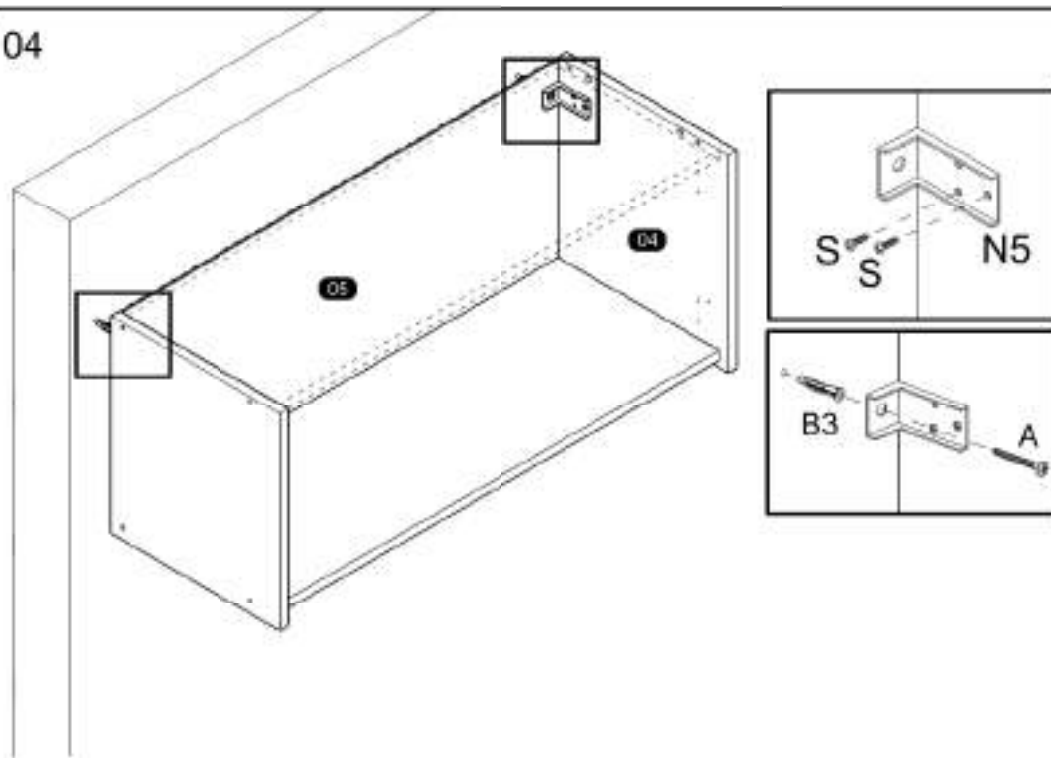

06

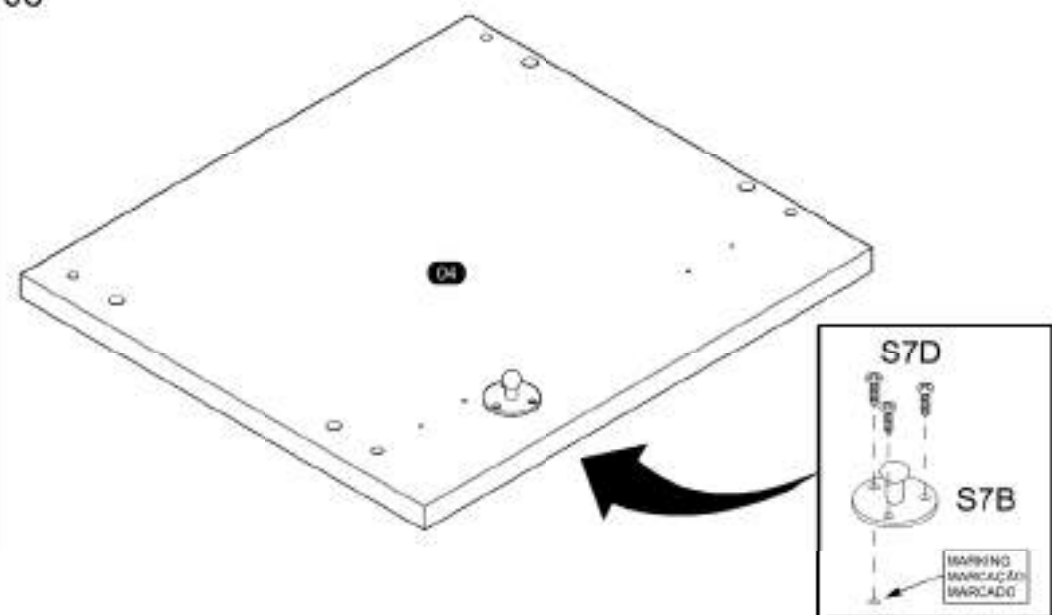

**MOUNTING ON THE CHOSEN DOOR MODEL**  
**MONTAGEM NO MODELO DE PORTA ESCOLHIDO / MONTAJE EN EL MODELO DE PUERTA ELEGIDO**

11

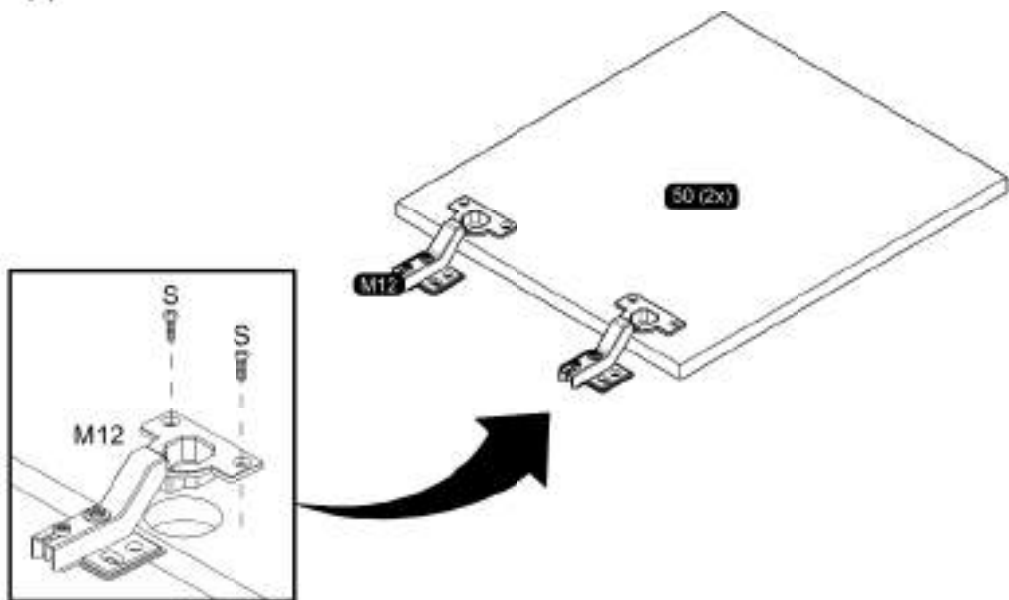

13

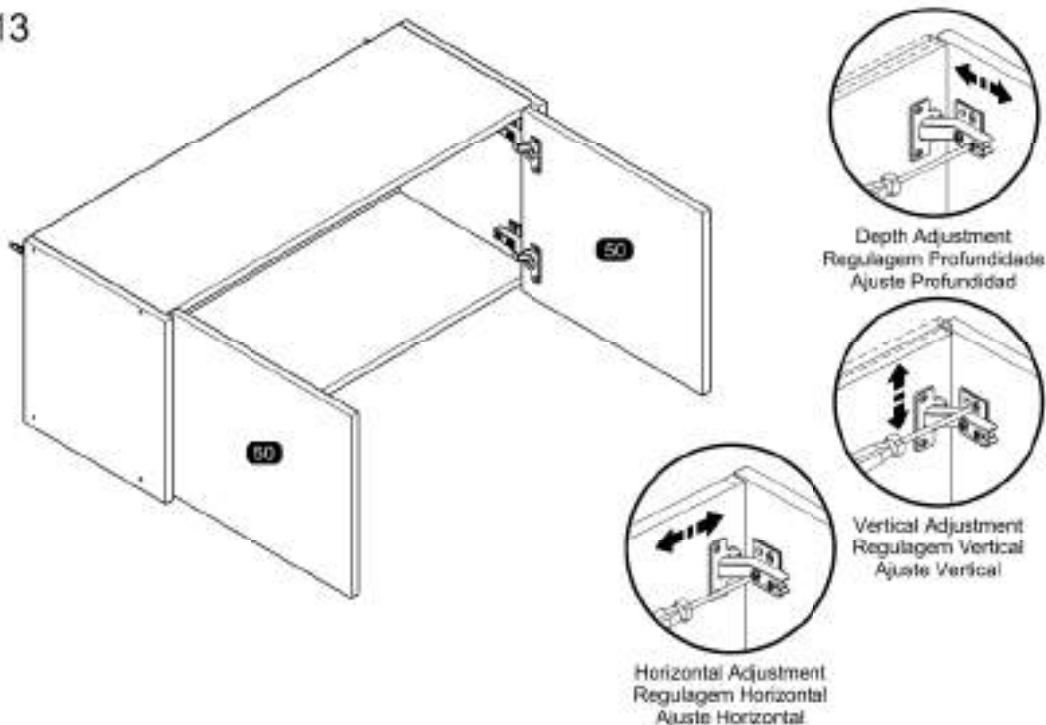

12

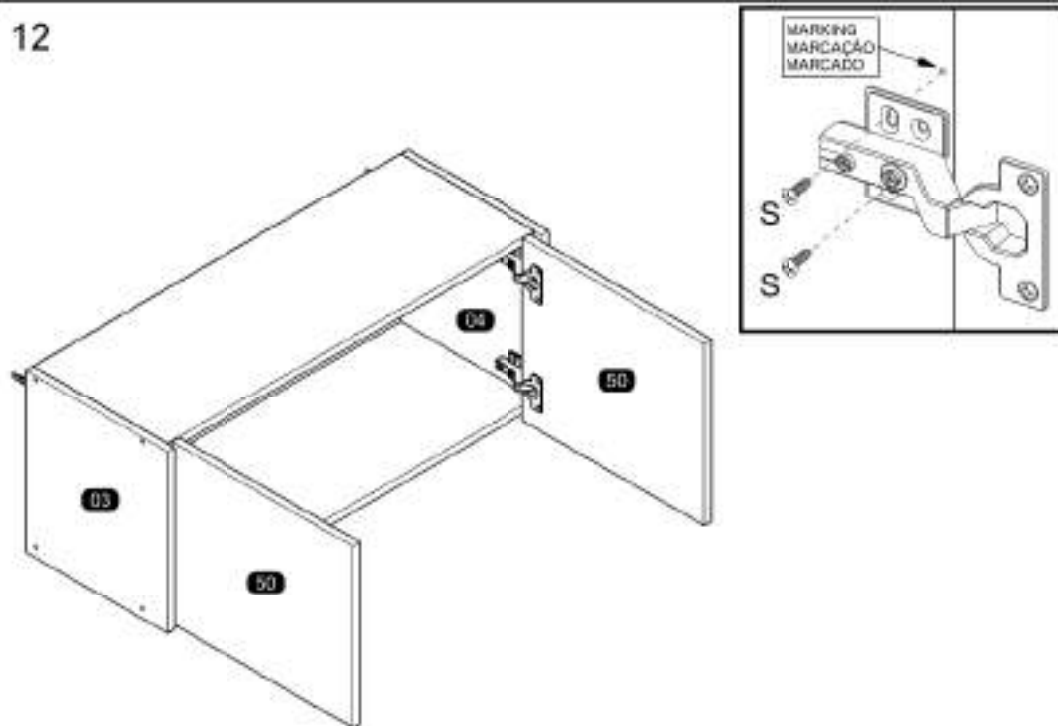

14

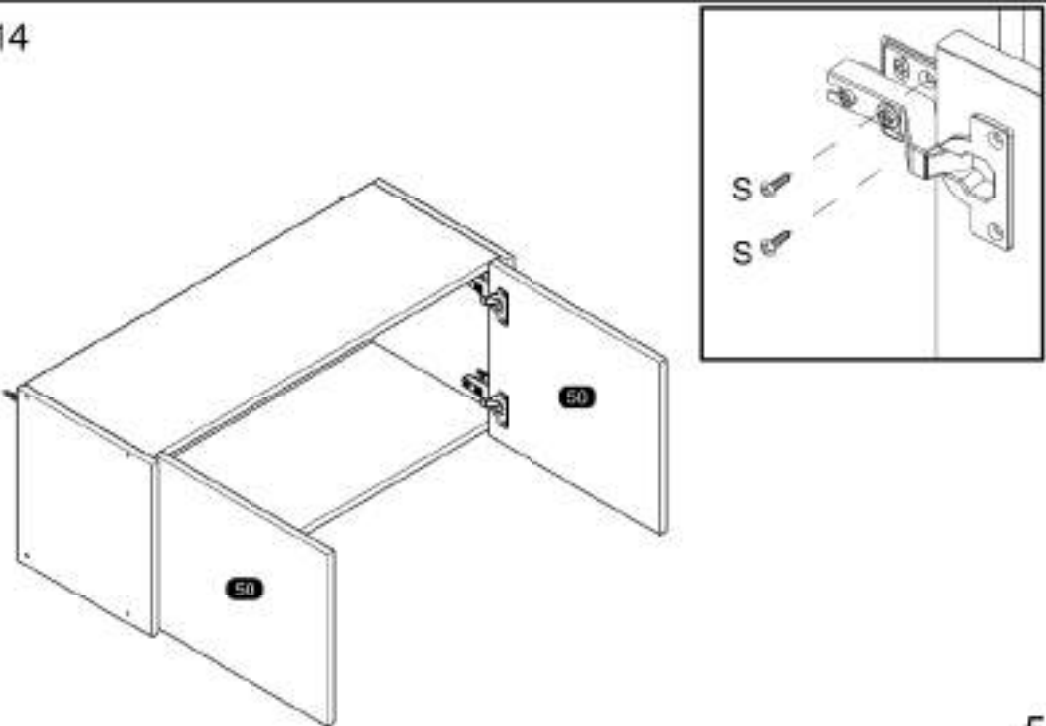

# ASSEMBLY INSTRUCTIONS MANUAL DE MONTAGEM / INSTRUCCIONES DE ARMADO

PANTRY CABINET 2 DOORS  
PANELEIRO 2P  
DESPENSERO 2 PUERTAS

Reference  
Referência  
Referencia **250486** | Revise  
| Revisão  
| Revisión **00**

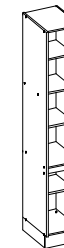

**YOU WILL NEED  
VOCÊ VAI PRECISAR DE / USTED NECESITARÁ**

Tools not supplied  
Ferramentas não fornecidas / Herramientas no incluidas

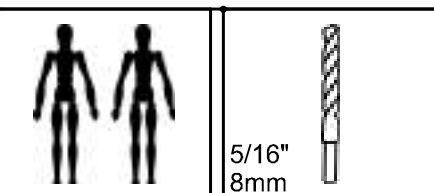

2 People  
2 Pessoas  
2 Personas

Drill bit  
Broca  
Taladro

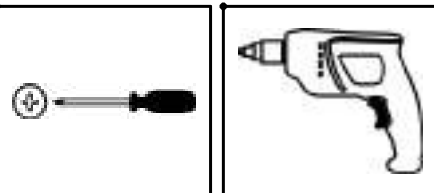

Screwdriver Phillips  
Chave Phillips  
Destornillador cruz

Drill machine  
Furadeira  
Taladro

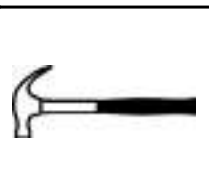

Hammer  
Martelo  
Martillo

**MAXIMUM RECOMMENDED WEIGHT  
BEING THIS EVENLY DISTRIBUTED.**  
**PESO MÁXIMO RECOMENDADO SENDO  
ESTE DISTRIBUÍDO UNIFORMEMENTE.**  
**PESO MÁXIMO RECOMENDADO SIENDO  
ESTE UNIFORMEMENTE DISTRIBUIDO.**

	LB	KG
D	11	5
F	22	10

**PARTS IDENTIFICATION  
IDENTIFICAÇÃO DAS PEÇAS / IDENTIFICACIÓN DE LAS PIEZAS**

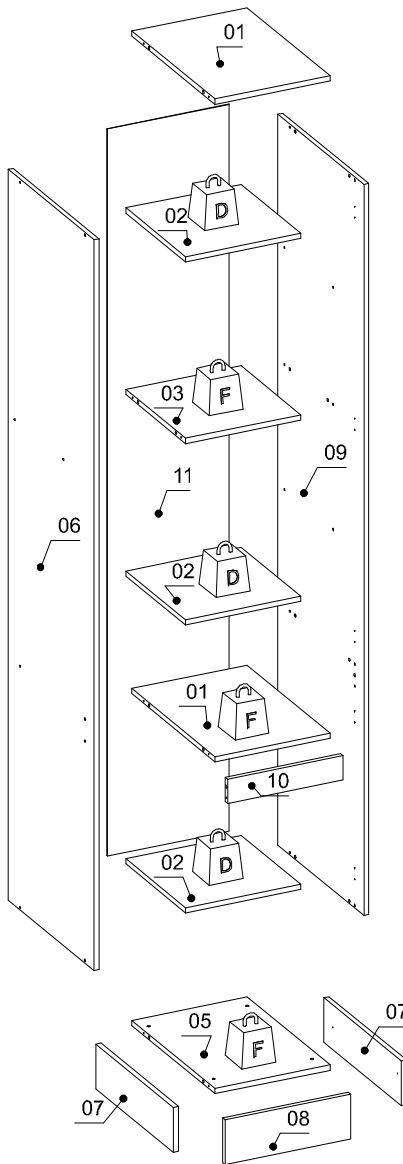

Nº	Measures_Inches	Medidas_cm	Qty./Qtd.
01	13 3/8 x 19 3/8 x 5/8	34.1 x 49.3 x 1.5	2
02	13 3/8 x 14 x 5/8	34.1 x 35.5 x 1.5	3
03	13 3/8 x 14 x 5/8	34.1 x 35.5 x 1.5	1
05	13 3/8 x 19 3/8 x 5/8	34.1 x 49.3 x 1.5	1
06	83 1/2 x 20 1/8 x 5/8	212.0 x 51.0 x 1.5	1
07	18 1/8 x 5 1/8 x 5/8	45.9 x 13.0 x 1.5	2
08	14 5/8 x 5 1/8 x 5/8	37.1 x 13.0 x 1.5	1
09	83 1/2 x 20 1/8 x 5/8	212.0 x 51.0 x 1.5	1
10	13 3/8 x 2 3/4 x 5/8	34.1 x 7.0 x 1.5	1
11	83 x 14 1/4 x 1/8	210.9 x 36.1 x 0.3	1

## IDENTIFICATION OF ACCESSORIES IDENTIFICAÇÃO DOS ACESSÓRIOS/ IDENTIFICACIÓN DE ACCESORIOS



The separation of the accessories before you start the assembly will facilitate the same. In case of doubt on the size of the screws and bolts, use the ruler at bottom of page.  
 A separação dos acessórios antes de iniciar a montagem facilitará a mesma. Em caso de dúvida no tamanho dos parafusos e cavilhas, utilize a régua ao final da página.  
 La separación de los accesorios antes de comenzar el armado facilitará el mismo. En caso de duda sobre el tamaño de los tornillos y taquetes, utilice la regla al pie de página.

A		Flanged head screw Parafuso flangeado / Tornillo de cabeza flangeada	5,0x90 mm	4
B3		Bushing Buchsa expansiva / Tapón	8x50 mm	4
E		Wooden dowel Cavilha / Taquete	8x30 mm	18
H8		Steel bracket Suporte de prateleira / Soporte de reposa	6x8 mm	12
L1		Flat head screw Parafuso chato / Tornillo de cabeza plana	7,0x40 mm	4
L3		Plastic Foot Soporte / Pie Plástico	-	4
M12		Metal hinge super tight Ombraçãca super alta / Bisagra alta	35 mm	5
N		Nail Prego / Clavo	10x10	48
N4		Loop Presilha / Presilla	-	6
N5		Support "L" Suporte "L" / Soporte "L"	-	4
O		Flat head screw Parafuso chato / Tornillo de cabeza plana	4,5x45 mm	18
S		Pan head screw Parafuso cabeça / Tornillo de pan	3,5x14 mm	44



## PRE-ASSEMBLE PRÉ-MONTAGEM / PRE ARMADO

01

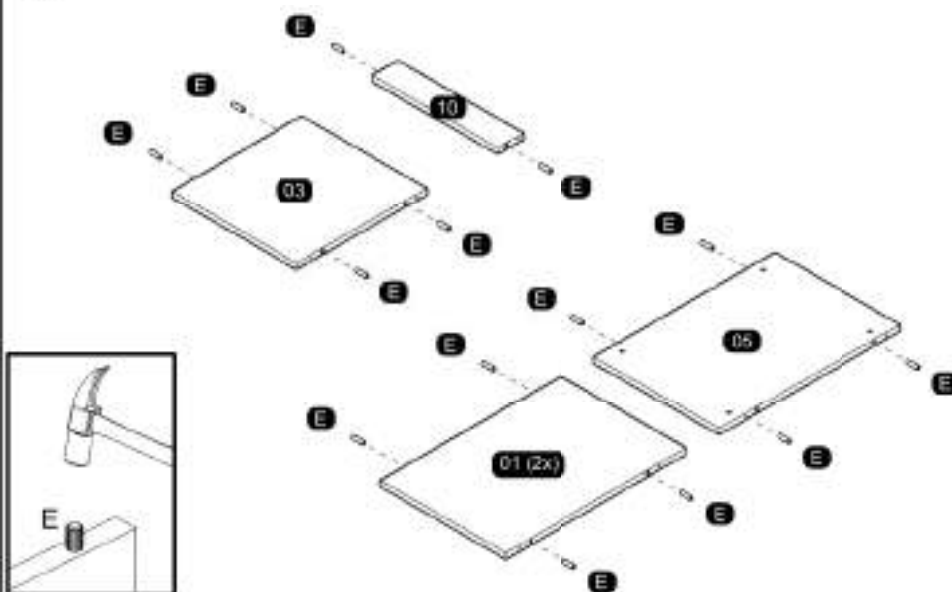

02

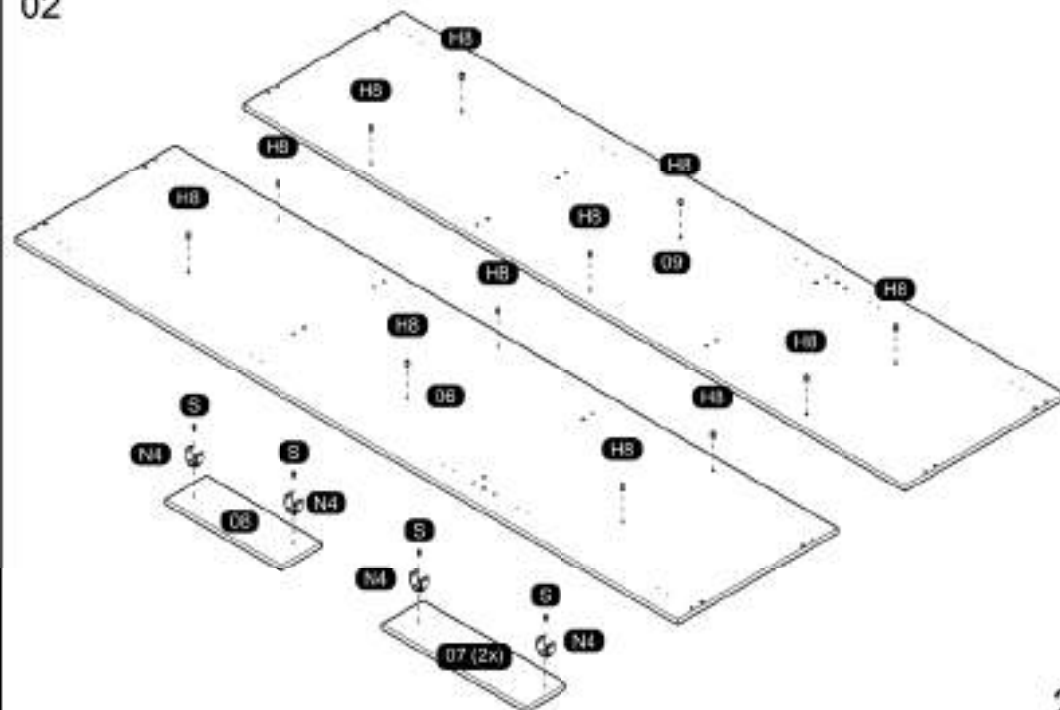

PRE-ASSEMBLE  
PRÉ-MONTAGEM / PRE ARMADO

03

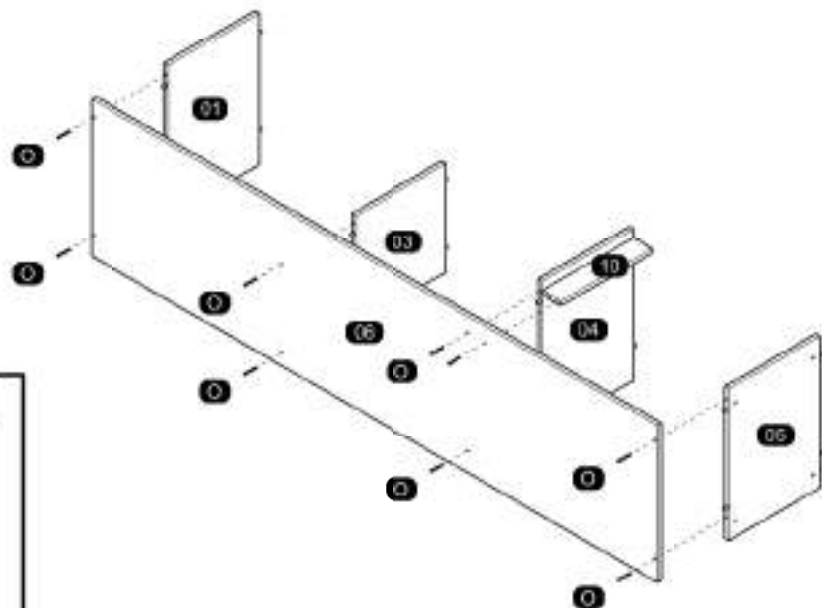

04

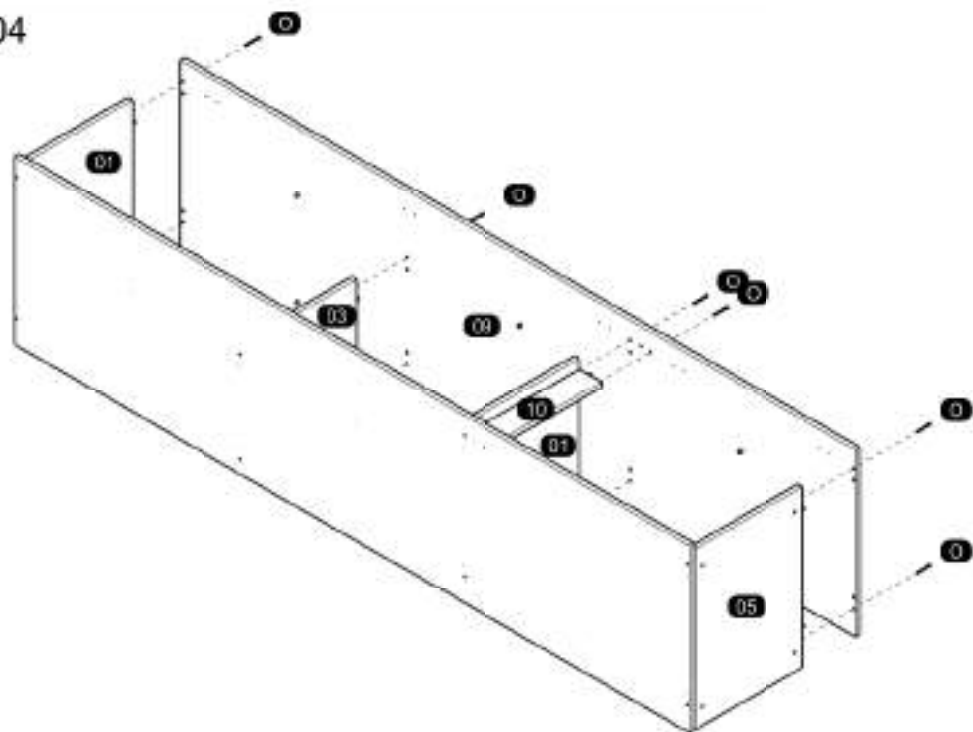

05

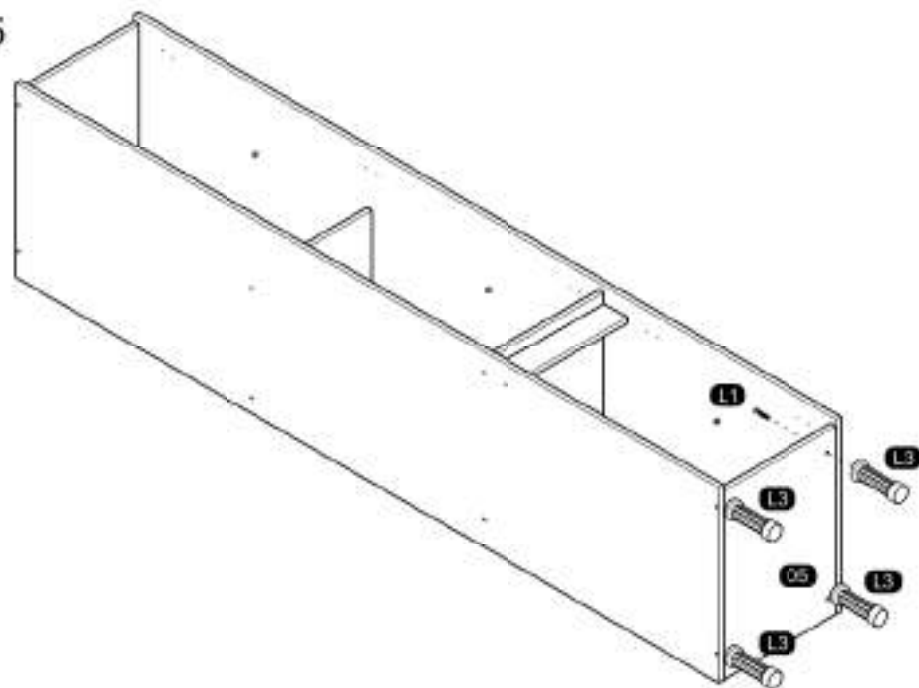

06

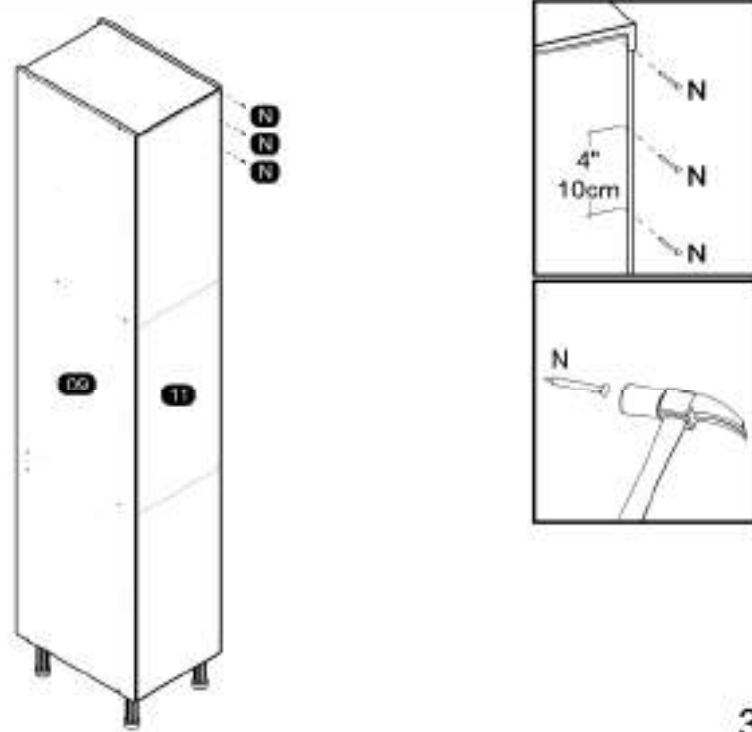

07

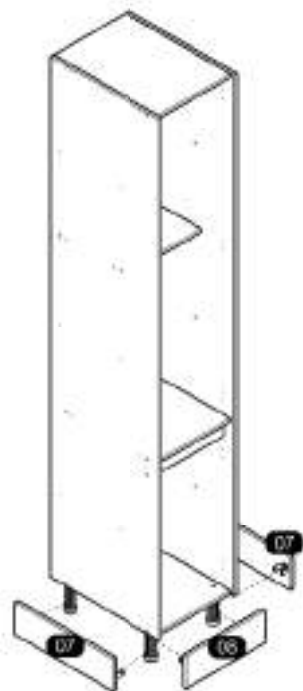

09

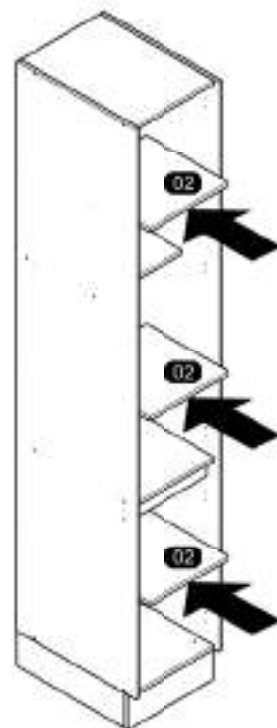

08

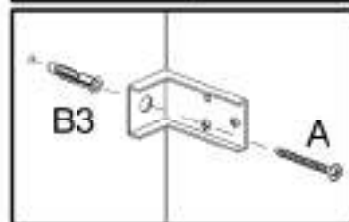
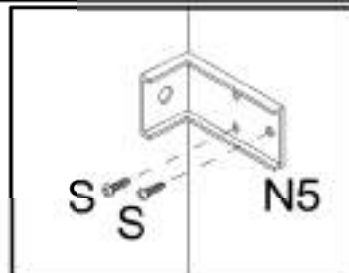
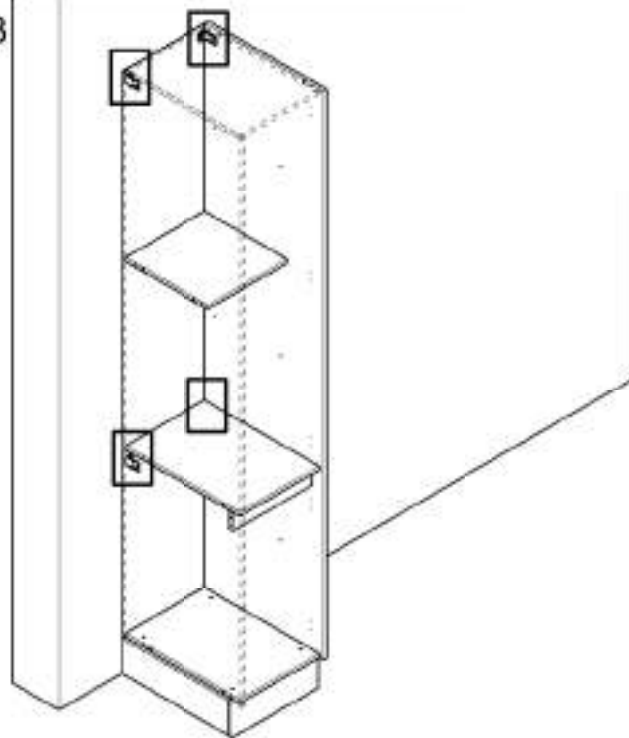

10

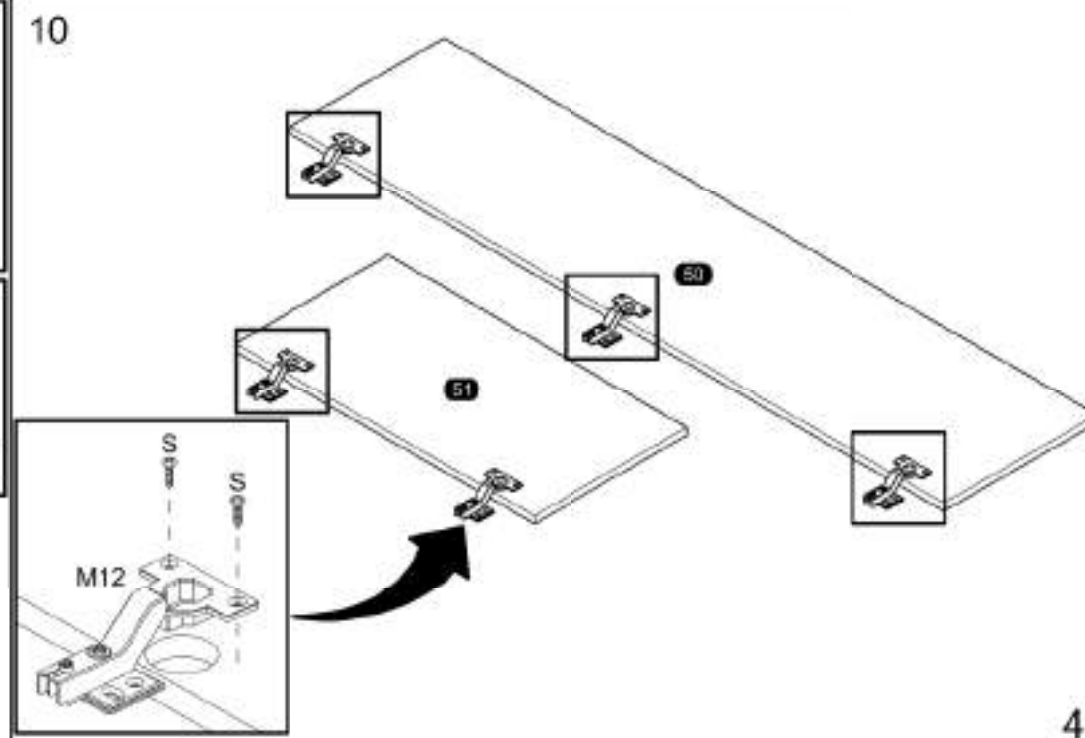

# ASSEMBLY INSTRUCTIONS MANUAL DE MONTAGEM / INSTRUCCIONES DE ARMADO

CABINET 2 DOORS  
BALCAO 2P  
GABINETE 2 PUERTAS

Reference  
Referência  
Referencia **250489** | Revise  
| Revisão  
| Revisión **00**

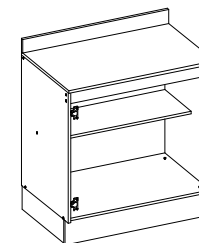

**YOU WILL NEED  
VOCÊ VAI PRECISAR DE / USTED NECESITARÁ**

Tools not supplied  
Ferramentas não fornecidas / Herramientas no incluidas

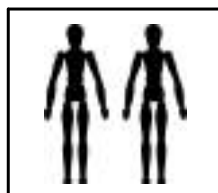

2 People  
2 Pessoas  
2 Personas

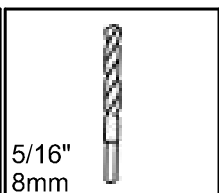

Drill bit  
Broca  
Taladro

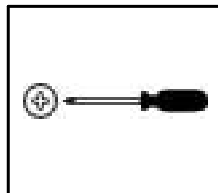

Screwdriver Phillips  
Chave Phillips  
Destornillador cruz



Drill machine  
Furadeira  
Taladro

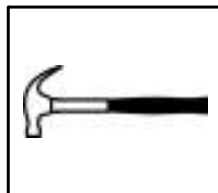

Hammer  
Martelo  
Martillo

**MAXIMUM RECOMMENDED WEIGHT  
BEING THIS EVENLY DISTRIBUTED.**  
**PESO MÁXIMO RECOMENDADO SENDO  
ESTE DISTRIBUÍDO UNIFORMEMENTE.**  
**PESO MÁXIMO RECOMENDADO SIENDO  
ESTE UNIFORMEMENTE DISTRIBUIDO.**

	LB	KG
—		
F	22	10
H	44	20

**PARTS IDENTIFICATION  
IDENTIFICAÇÃO DAS PEÇAS / IDENTIFICACIÓN DE LAS PIEZAS**

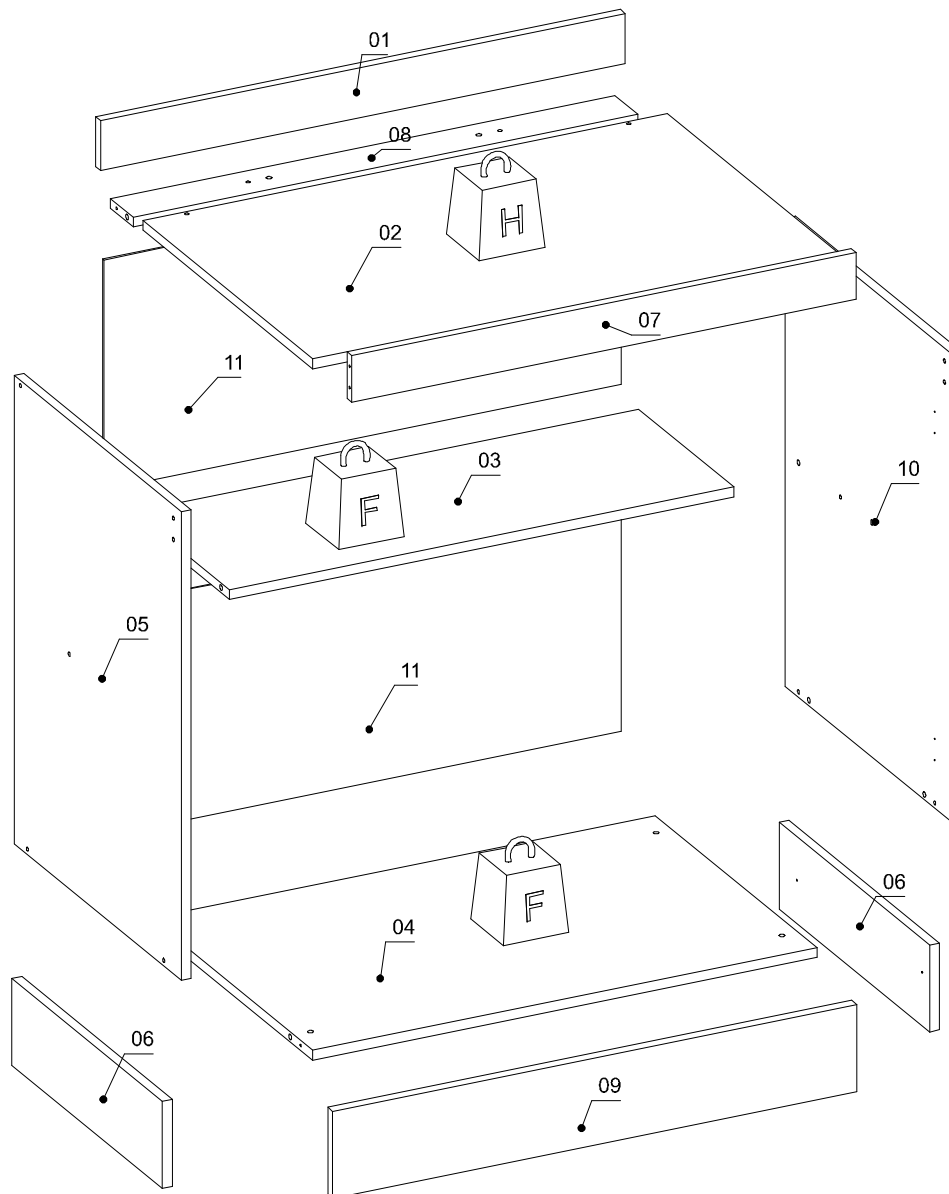

Nº	Measures_Inches	Medidas_cm	Qty./Qtd.
01	31 1/2 x 3 x 5/8	80.0 x 7.5 x 1.5	1
02	31 1/2 x 20 3/8 x 5/8	80.0 x 51.8 x 1.5	1
03	30 1/4 x 11 3/8 x 5/8	76.9 x 29.0 x 1.5	1
04	30 1/4 x 19 3/8 x 5/8	76.9 x 49.3 x 1.5	1
05	27 1/2 x 20 1/8 x 5/8	70.0 x 51.0 x 1.5	1
06	18 1/8 x 5 1/8 x 5/8	45.9 x 13.0 x 1.5	2
07	30 1/4 x 2 3/4 x 5/8	76.9 x 7.0 x 1.5	1
08	30 1/4 x 2 3/4 x 5/8	76.9 x 7.0 x 1.5	1
09	31 1/2 x 5 1/8 x 5/8	79.9 x 13.0 x 1.5	1
10	27 1/2 x 20 1/8 x 5/8	70.0 x 51.0 x 1.5	1
11	31 1/8 x 13 1/2 x 1/8	78.9 x 34.4 x 0.3	2

## IDENTIFICATION OF ACCESSORIES IDENTIFICAÇÃO DOS ACESSÓRIOS/ IDENTIFICACIÓN DE ACCESORIOS



The separation of the accessories before you start the assembly will facilitate the same. In case of doubt on the size of the screws and bolts, use the ruler at bottom of page.  
 A separação dos acessórios antes de iniciar a montagem facilitará a mesma. Em caso de dúvida no tamanho dos parafusos e cavilhas, utilize a régua ao final da página.  
 La separación de los accesorios antes de comenzar el armado facilitará el mismo. En caso de duda sobre el tamaño de los tornillos y taquetes, utilice la regla al pie de página.

A		Flanged head screw Parafuso fangado / Tornillo de cabeza fangada	5,0x60 mm	2
B3		Bushing Buchia expansiva / Tapón	8x50 mm	2
C1		Metal claw Garrá de metal / Goma metal	-	4
D		Flat head screw Parafuso chato / Tornillo de cabeça plana	4,0x40 mm	2
E		Wooden dowel Cavilha / Taquete	8x30 mm	10
L1		Flat head screw Parafuso chato / Tornillo de cabeça plana	7,0x40 mm	4
L3		Plastic foot Sapata / Pá Plástico	-	4
M12		Metal hinge super light Dobradilha super alta / Bisagra alta	35 mm	4
M1		Flat head screw Parafuso chato / Tornillo de cabeça plana	3,5x25 mm	2
N		Nail Prego / Clavo	10x10	36
N4		Loop Presilha / Presilla	-	6
N5		Support "L" Suporte "L" / Soporte "L"	-	2
N7		Wooden dowel Cavilha / Taquete	8x20 mm	2
O		Flat head screw Parafuso chato / Tornillo de cabeça plana	4,5x45 mm	12
S		Pan head screw Parafuso panela / Tornillo de pan	3,5x14 mm	40
Y18		Zamac bracket Cantoneira zamac / Soporte de zamac	13x13 mm	3



## PRE-ASSEMBLE PRÉ-MONTAGEM / PRE ARMADO

01

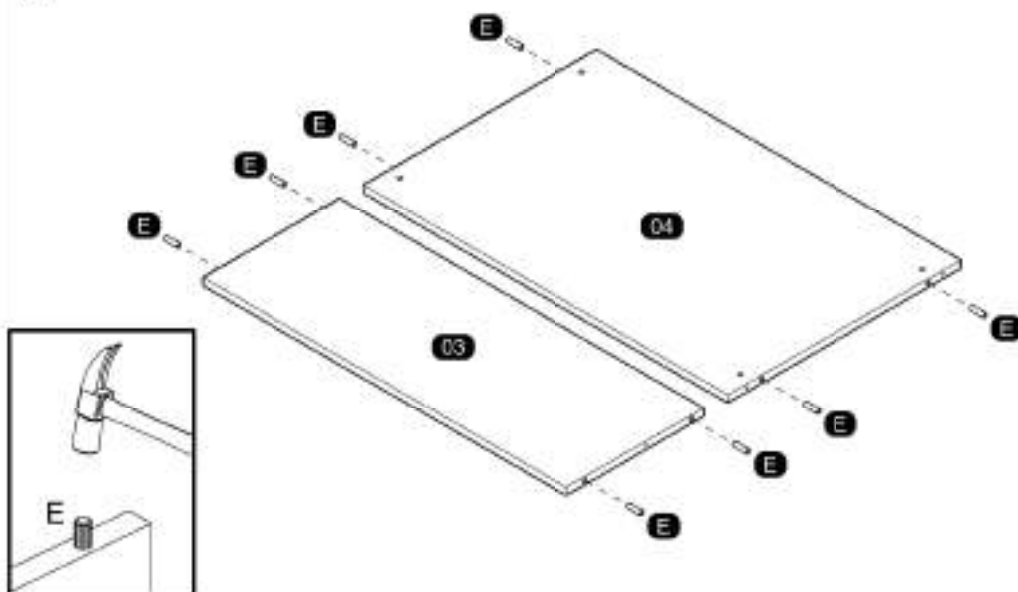

02

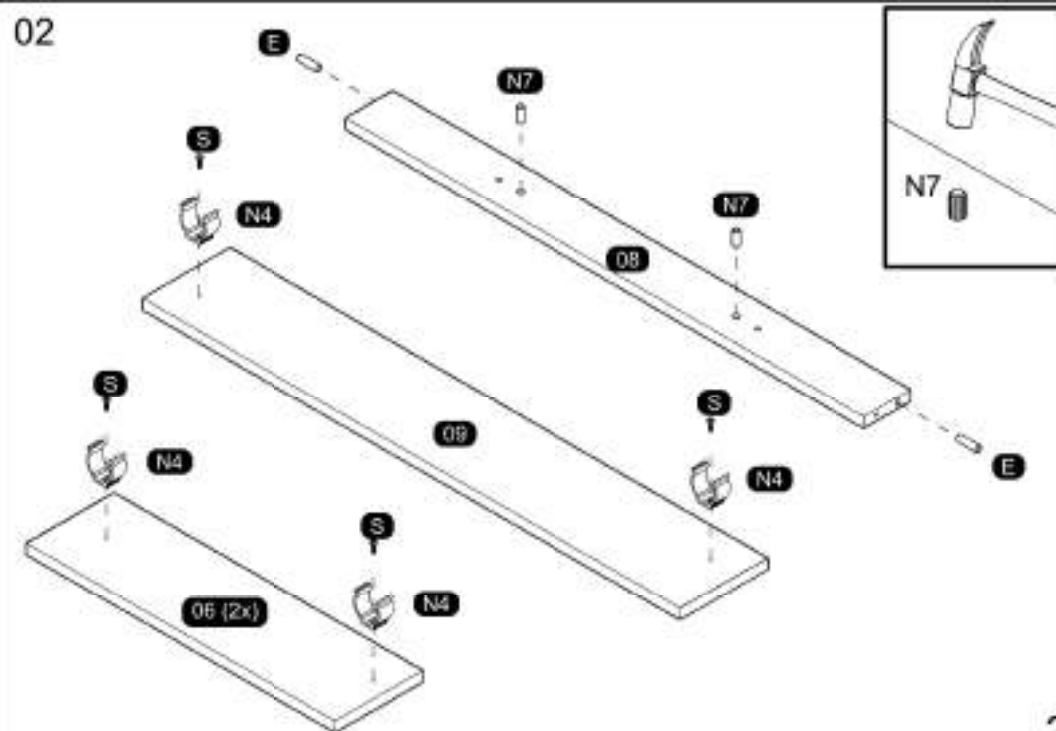

**ASSEMBLY  
MONTAGEM / ARMADO**

03

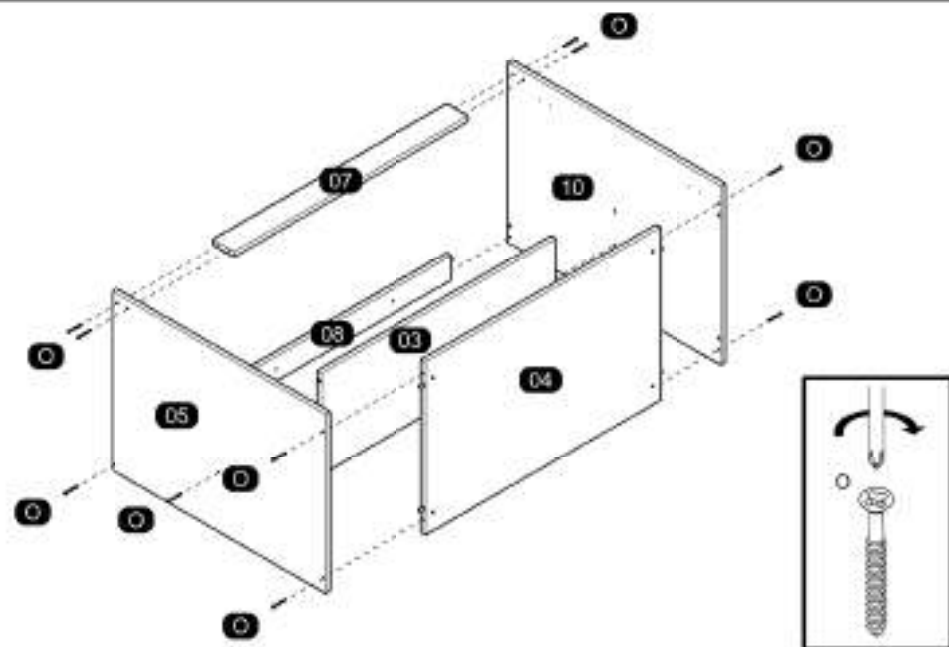

05

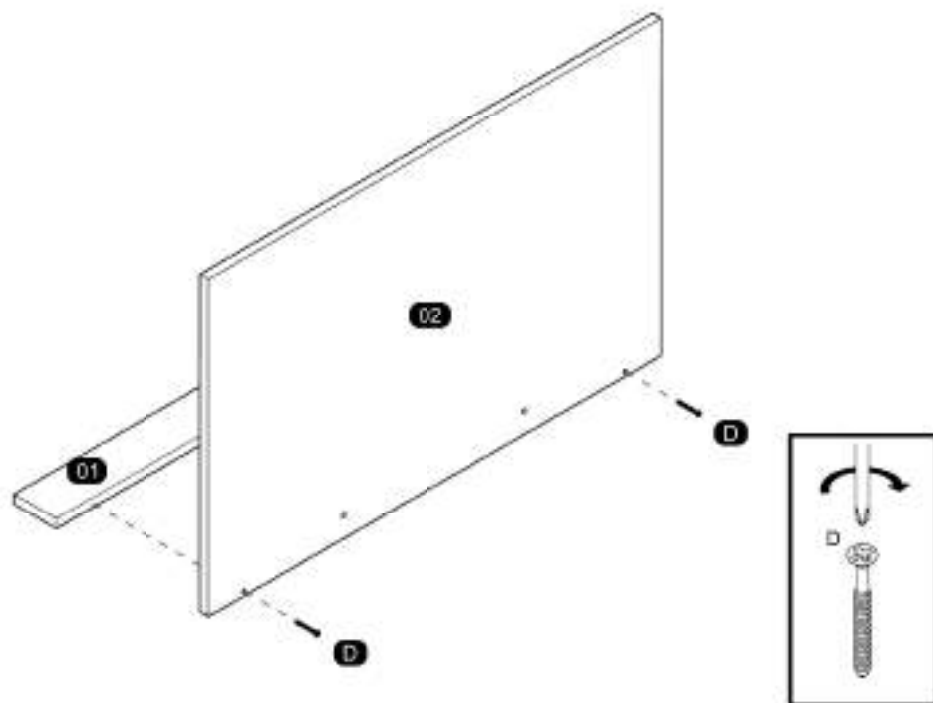

04

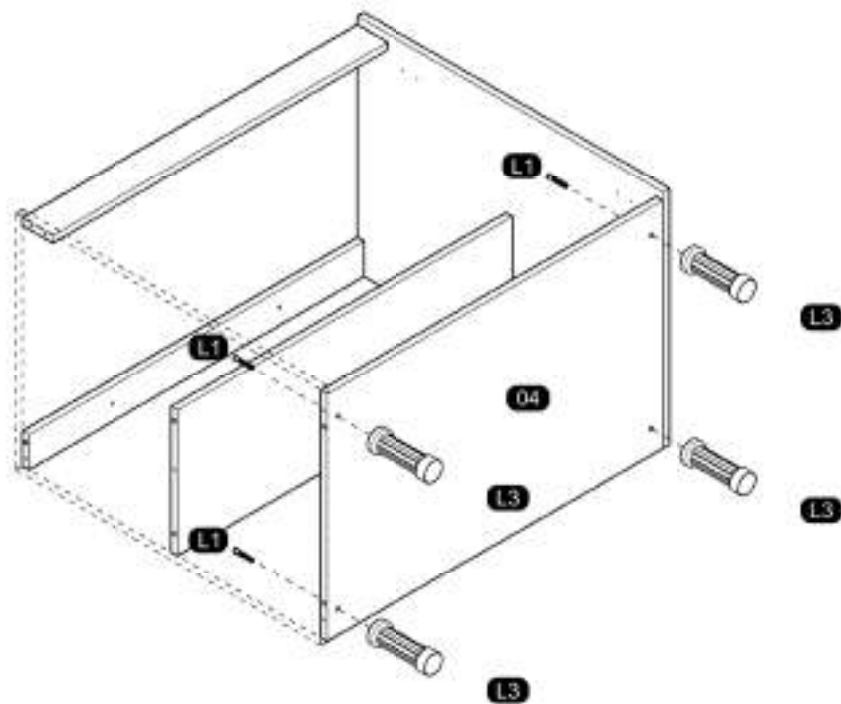

06

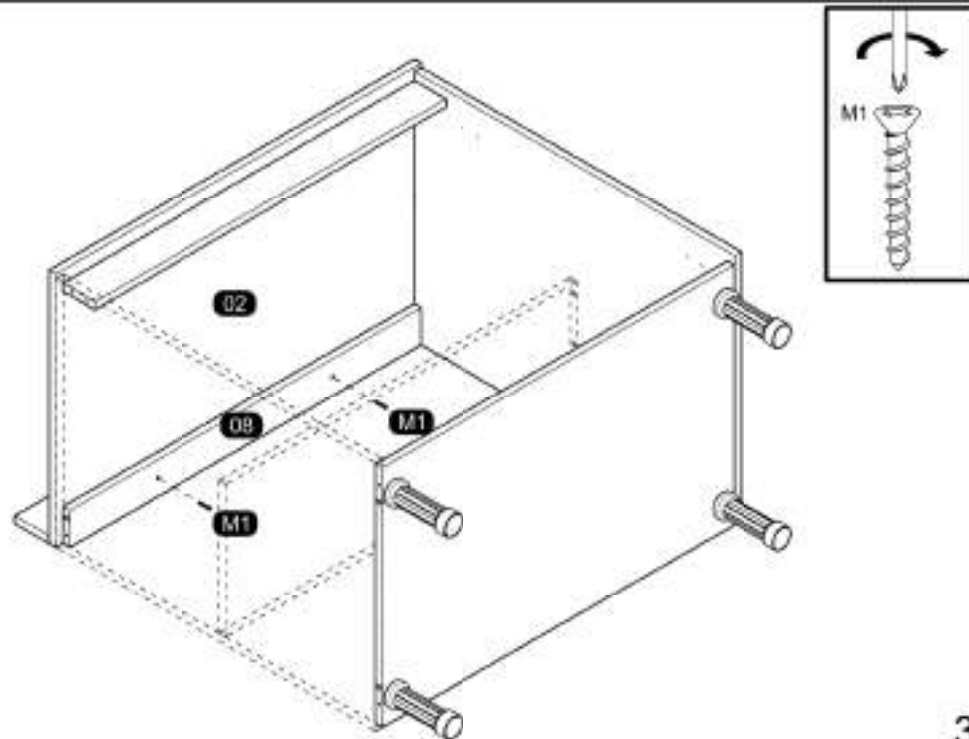

07

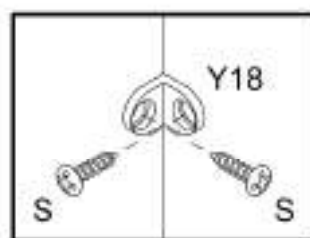
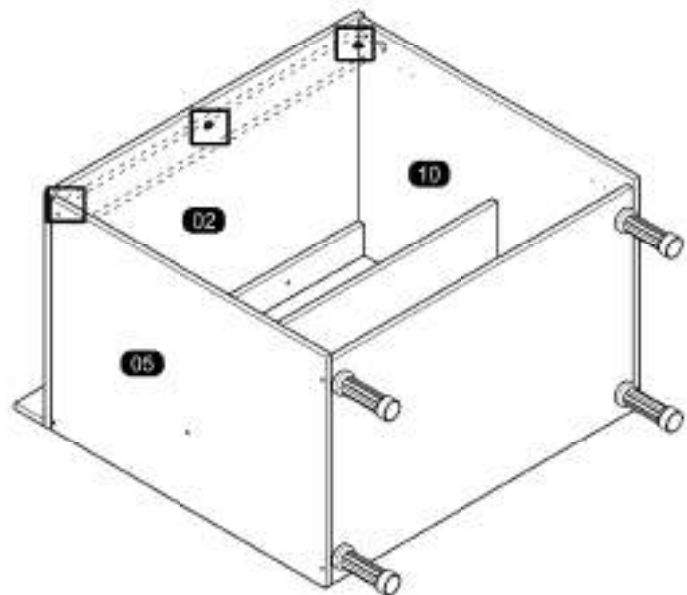

09

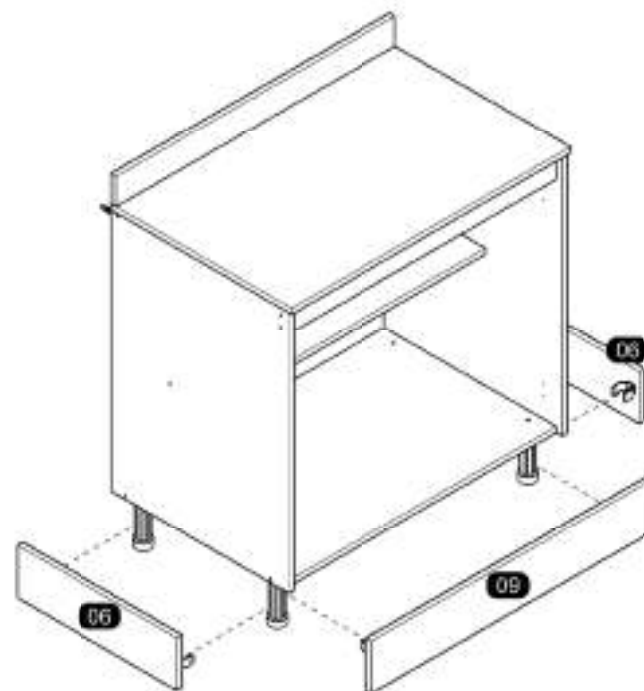

08

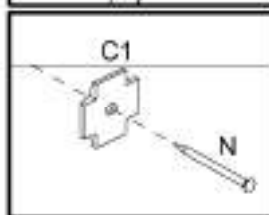
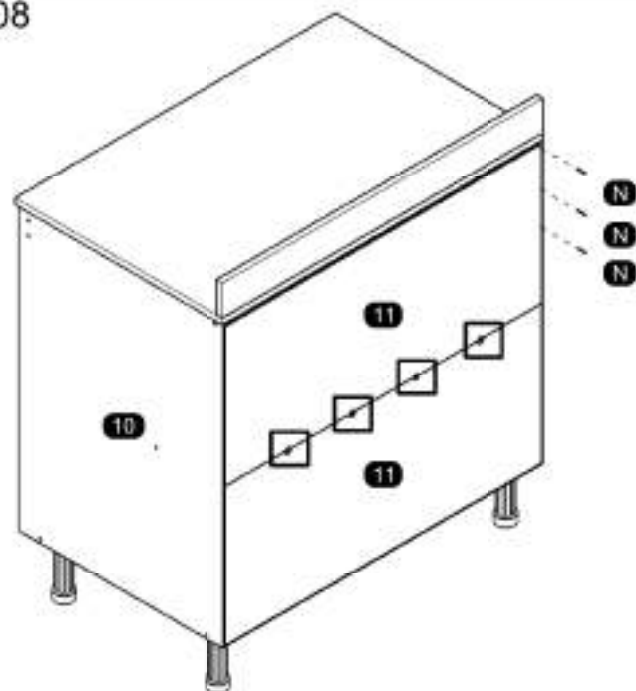

10

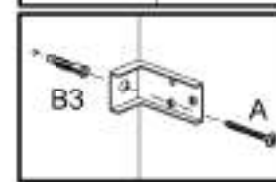
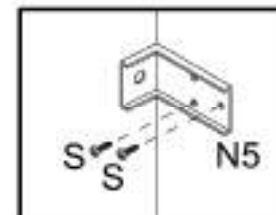
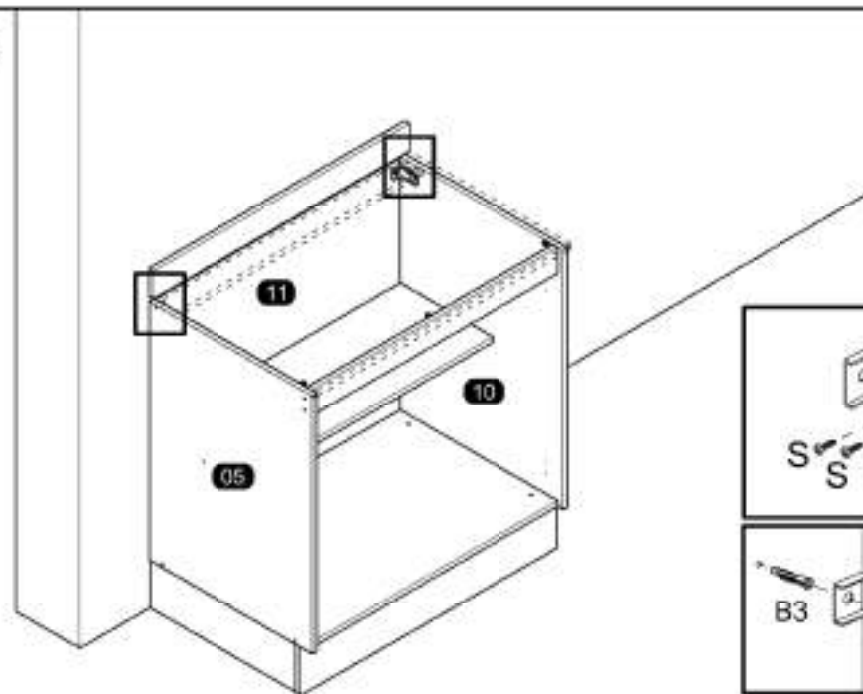

# ASSEMBLY INSTRUCTIONS MANUAL DE MONTAGEM / INSTRUCCIONES DE ARMADO

BASE CABINET 2 DOORS 3 DRAWERS  
BALCAO 2P 3G  
GABINETE 2 PUERTAS 3 CAJONES

Reference  
Referência  
Referencia **250490** | Revise  
| Revisão  
| Revisión **00**

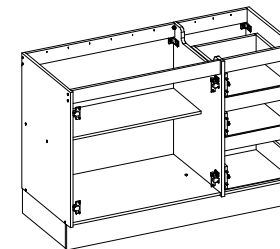

**YOU WILL NEED  
VOCÊ VAI PRECISAR DE / USTED NECESITARÁ**

Tools not supplied  
Ferramentas não fornecidas / Herramientas no incluidas

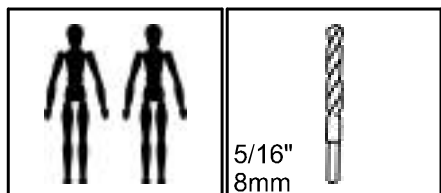

2 People  
2 Pessoas  
2 Personas

Drill bit  
Broca  
Taladro

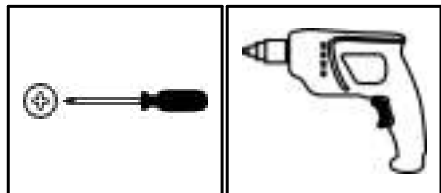

Screwdriver Phillips  
Chave Phillips  
Destornillador cruz

Drill machine  
Furadeira  
Taladro

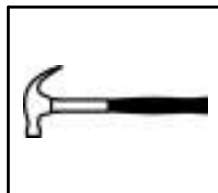

Hammer  
Martelo  
Martillo

**MAXIMUM RECOMMENDED WEIGHT  
BEING THIS EVENLY DISTRIBUTED.**  
**PESO MÁXIMO RECOMENDADO SENDO  
ESTE DISTRIBUÍDO UNIFORMEMENTE.**  
**PESO MÁXIMO RECOMENDADO SIENDO  
ESTE UNIFORMEMENTE DISTRIBUIDO.**

	LB	KG
D	11	5
F	22	10

**PARTS IDENTIFICATION  
IDENTIFICAÇÃO DAS PEÇAS / IDENTIFICACIÓN DE LAS PIEZAS**

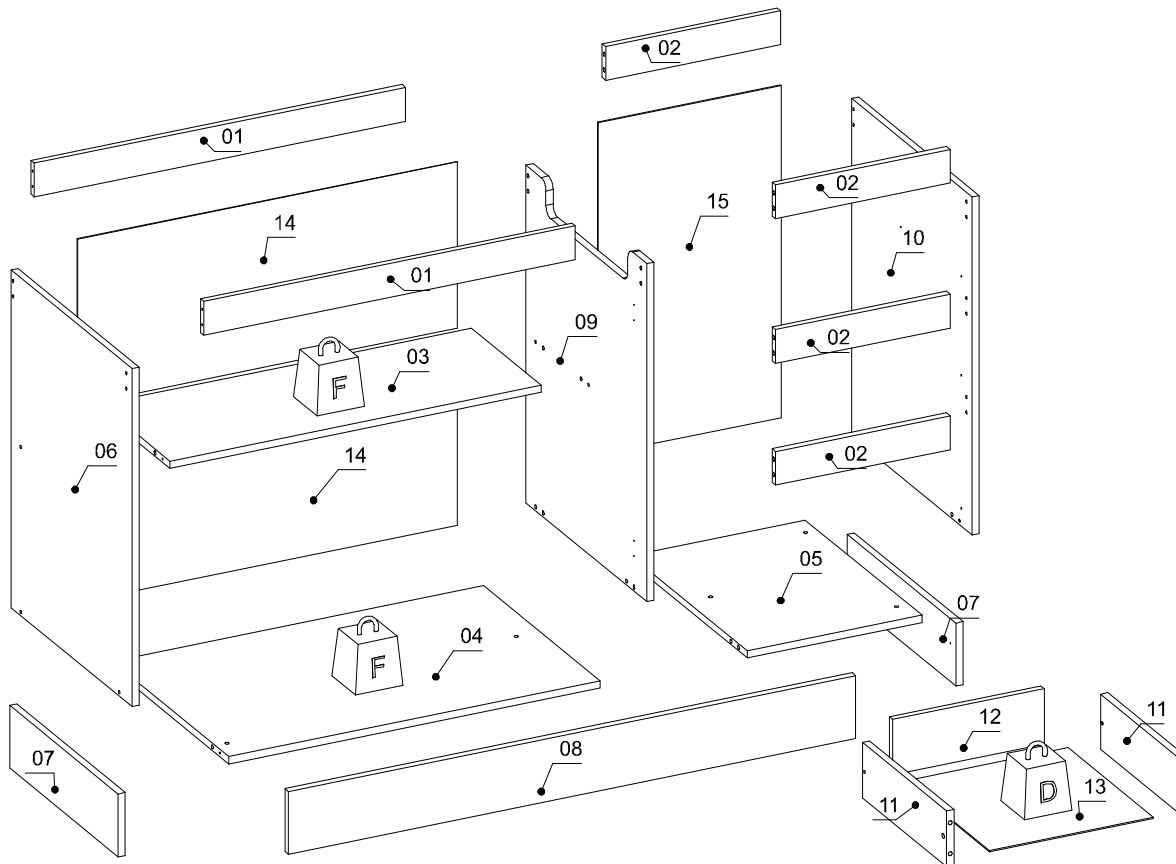

Nº	Measures_Inches	Medidas_cm	Qty./Qtd.
01	30 7/8 x 2 3/4 x 5/8	78.5 x 7.0 x 1.5	2
02	14 1/2 x 2 3/4 x 5/8	36.9 x 7.0 x 1.5	4
03	30 7/8 x 11 5/8 x 5/8	78.5 x 29.4 x 1.5	1
04	30 7/8 x 19 3/8 x 5/8	78.5 x 49.3 x 1.5	1
05	14 1/2 x 19 3/8 x 5/8	36.9 x 49.3 x 1.5	1
06	27 1/2 x 20 1/8 x 5/8	70.0 x 51.0 x 1.5	1
07	18 1/8 x 5 1/8 x 5/8	45.9 x 13.0 x 1.5	2
08	47 1/4 x 5 1/8 x 5/8	119.9 x 13.0 x 1.5	1
09	27 1/2 x 20 1/8 x 5/8	70.0 x 51.0 x 1.5	1
10	27 1/2 x 20 1/8 x 5/8	70.0 x 51.0 x 1.5	1
11	14 x 4 1/2 x 5/8	35.5 x 11.5 x 1.5	6
12	12 5/8 x 4 1/2 x 5/8	32.0 x 11.5 x 1.5	3
13	14 1/8 x 13 5/8 x 1/8	36.0 x 34.6 x 0.3	3
14	31 5/8 x 13 1/2 x 1/8	80.2 x 34.4 x 0.3	2
15	27 1/8 x 15 1/4 x 1/8	68.8 x 38.6 x 0.3	1

## IDENTIFICATION OF ACCESSORIES IDENTIFICAÇÃO DOS ACESSÓRIOS/ IDENTIFICACIÓN DE ACCESORIOS



The separation of the accessories before you start the assembly will facilitate the same. In case of doubt on the size of the screws and bolts, use the ruler at bottom of page.  
 A separação dos acessórios antes de iniciar a montagem facilitará a mesma. Em caso de dúvida no tamanho dos parafusos e cavilhas, utilize a régua ao final da página.  
 La separación de los accesorios antes de comenzar el armado facilitará el mismo. En caso de duda sobre el tamaño de los tornillos y taquetes, utilice la regla al pie de página.

A		Flanged head screw Parafuso fangado / Tornillo de cabeza fangada	5,0x60 mm	3
A3		Trapezoid Trapecio / Trapecio	-	6
B3		Bushing Buchá expansiva / Tapón	8x50 mm	3
C1		Metal claw Garrá de metal / Gansá metal	-	9
D		Flat head screw Parafuso chato / Tornillo de cabeza plana	4,0x40 mm	6
E		Wooden dowel Cavilha / Taquete	8x30 mm	24
F		Wooden dowel Cavilha / Taquete	8x50 mm	6
K		Double minifix screw Haste minifix dupla / Tornillo minifix doble	60mm	2
L		Drum lock Tambor minifix / Tambor minifix	12 mm	4
L1		Flat head screw Parafuso chato / Tornillo de cabeza plana	7,0x40 mm	6
L3		Plastic foot Sapata / Pie Plástico	-	6
L9		Flat head screw Parafuso chato / Tornillo de cabeza plana	3,5x12 mm	30
L17		Telescopic slide Coneção telescópica / Conector telescópico	350 mm	6
M12		Metal hinge super high Dobradiça super alta / Bisagra alta	35 mm	4
N		Nail Prego / Clavo	10x10	87
N4		Loop Presilha / Presilla	-	6
N5		Support "L" Suporte "L" / Soporte "L"	-	3
O		Flat head screw Parafuso chato / Tornillo de cabeza plana	4,5x45 mm	20
P		Pan head screw Parafuso cabeça / Tornillo de pan	4,5x25 mm	6
S		Pan head screw Parafuso cabeça / Tornillo de pan	3,5x14 mm	48
Y18		Zamac bracket Coneção zamac / Soporte de zamac	13x13 mm	6



## PRE-ASSEMBLE PRÉ-MONTAGEM / PRE ARMADO

01

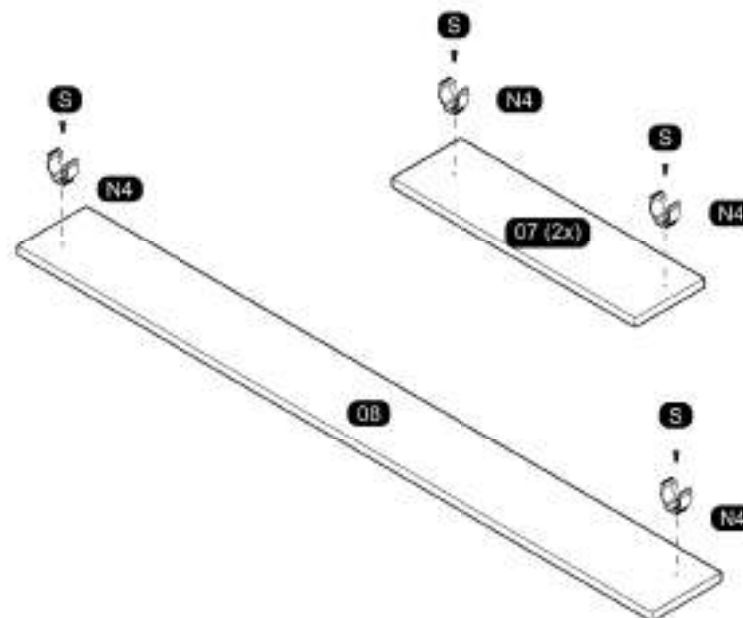

02

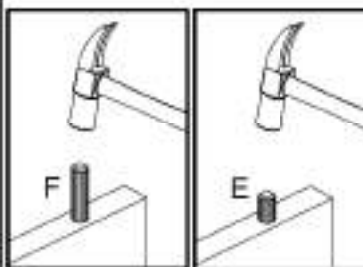
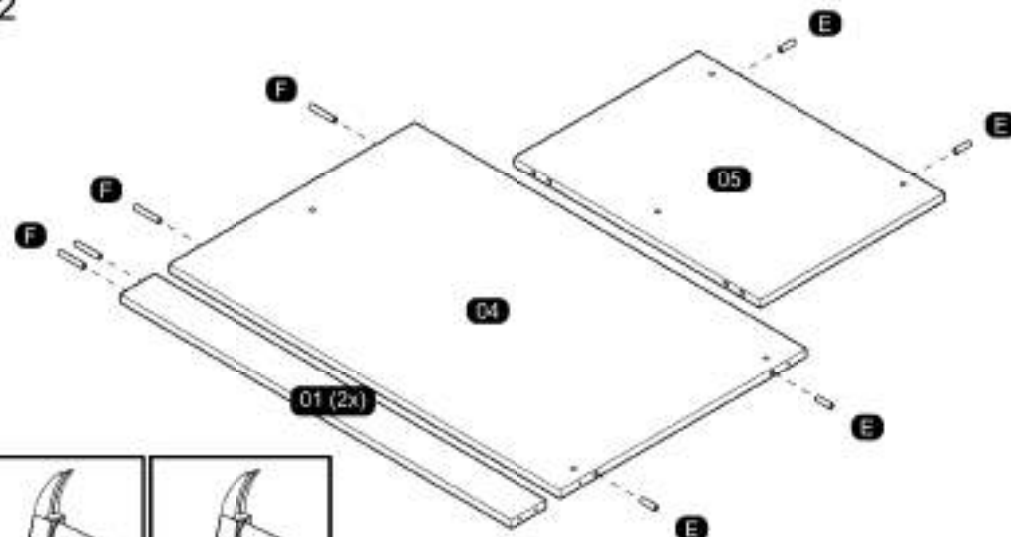



07

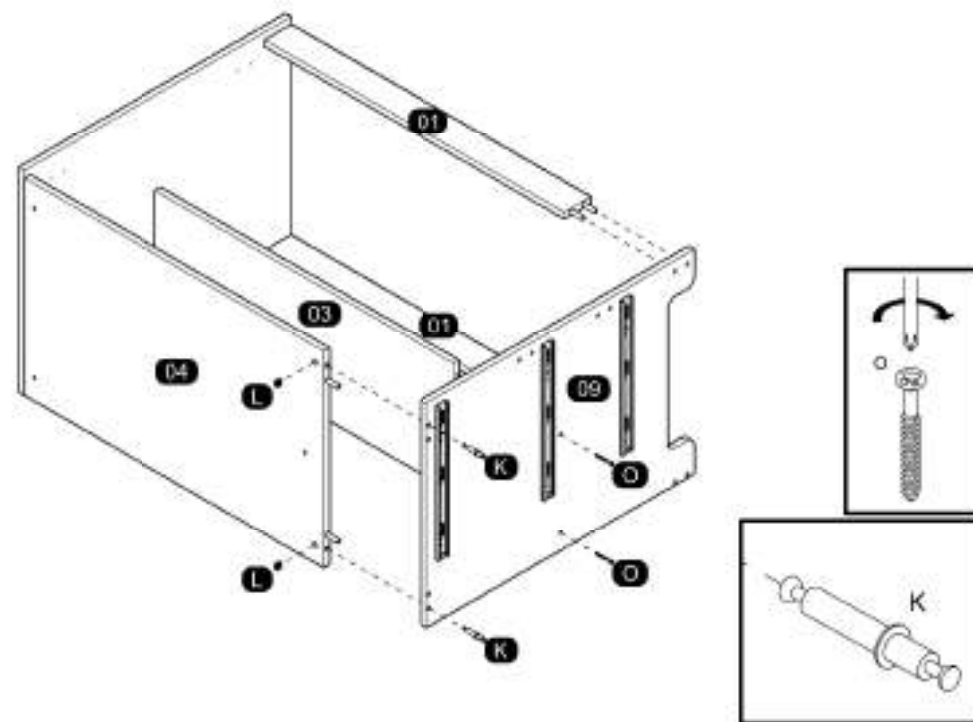

09

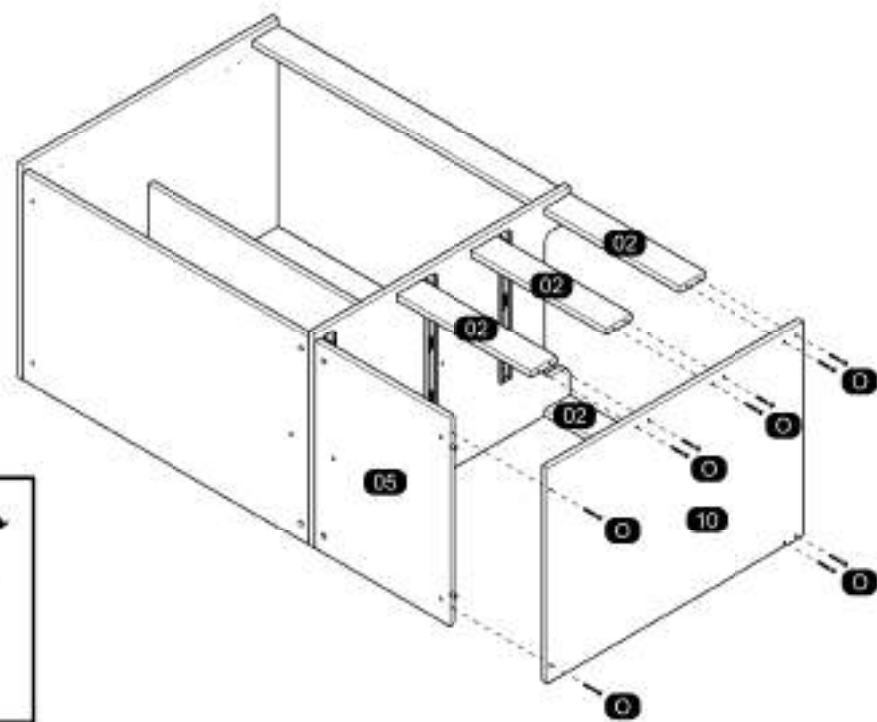

08

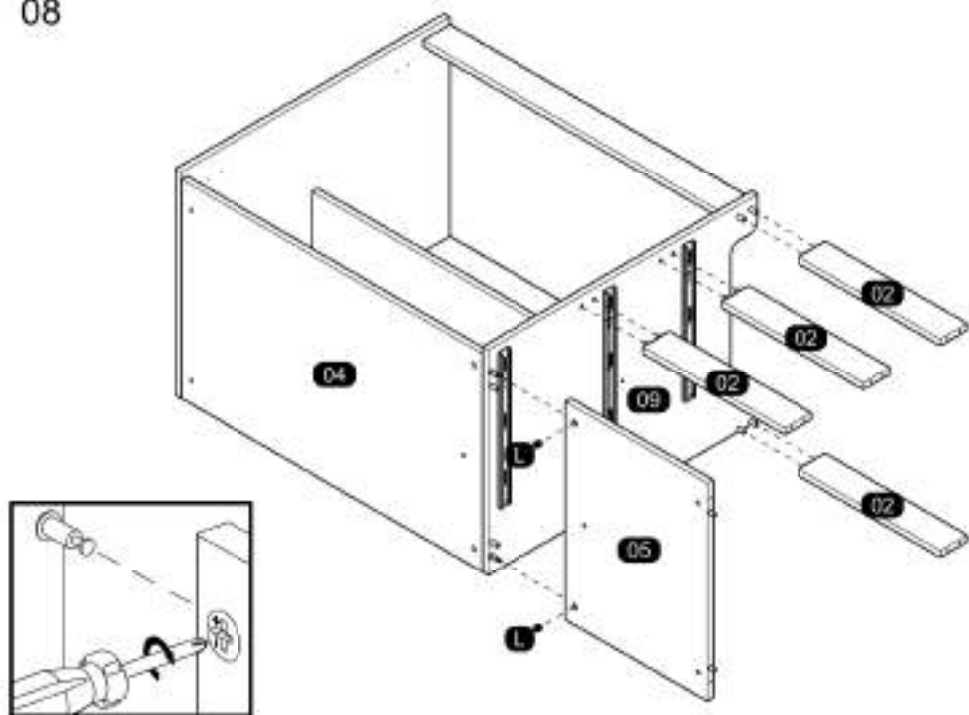

10

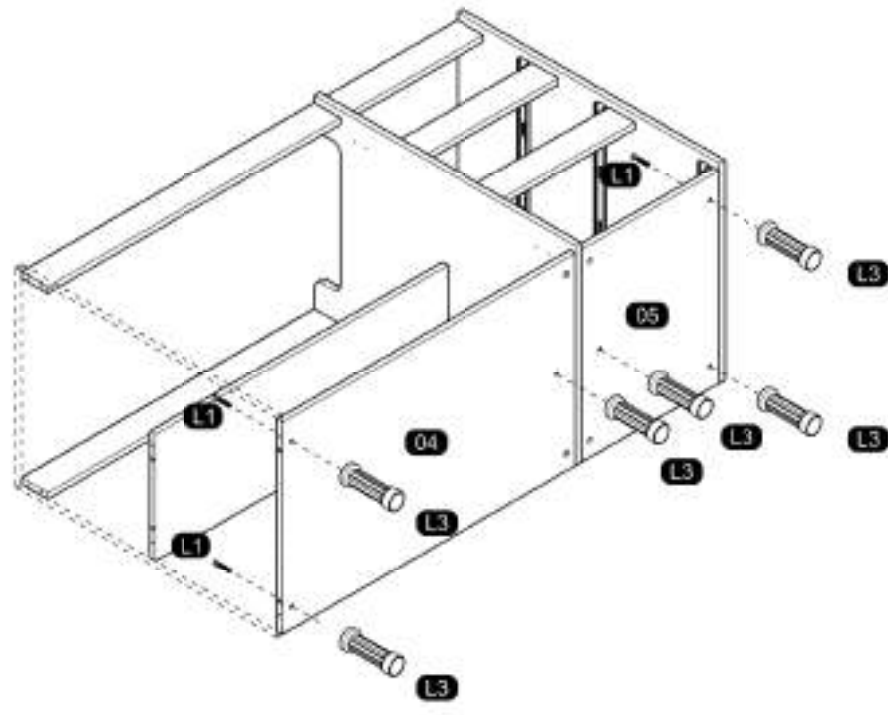



# ASSEMBLY INSTRUCTIONS MANUAL DE MONTAGEM / INSTRUCCIONES DE ARMADO

WALL CABINET 1 FLAP DOOR / 2 SMALLER DOORS

ARMARIO AEREO 1PB / 2P MENOR

ARMARIO DE PARED 1 PUERTA HORIZONTAL / 2 PUERTAS PEQUEÑAS

Reference | Revise  
Referência | Revisão  
Referencia | Revisión

## 250485

## 00

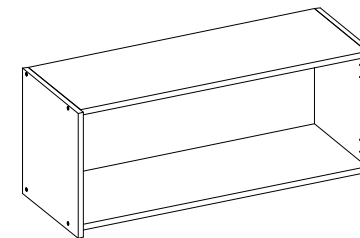

### YOU WILL NEED VOCÊ VAI PRECISAR DE / USTED NECESITARÁ

Tools not supplied  
Ferramentas não fornecidas / Herramientas no incluidas

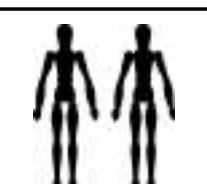

2 People  
2 Pessoas  
2 Personas

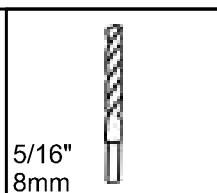

Drill bit  
Broca  
Taladro

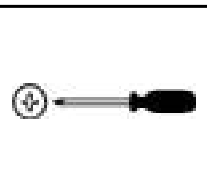

Screwdriver Phillips  
Chave Phillips  
Destornillador cruz



Drill machine  
Furadeira  
Taladro



Hammer  
Martelo  
Martillo

MAXIMUM RECOMMENDED WEIGHT BEING THIS EVENLY DISTRIBUTED.  
PESO MÁXIMO RECOMENDADO SENDO ESTE DISTRIBUÍDO UNIFORMEMENTE.  
PESO MÁXIMO RECOMENDADO SIENDO ESTE UNIFORMEMENTE DISTRIBUIDO.

	LB	KG
E	17	8

### PARTS IDENTIFICATION IDENTIFICAÇÃO DAS PEÇAS / IDENTIFICACIÓN DE LAS PIEZAS

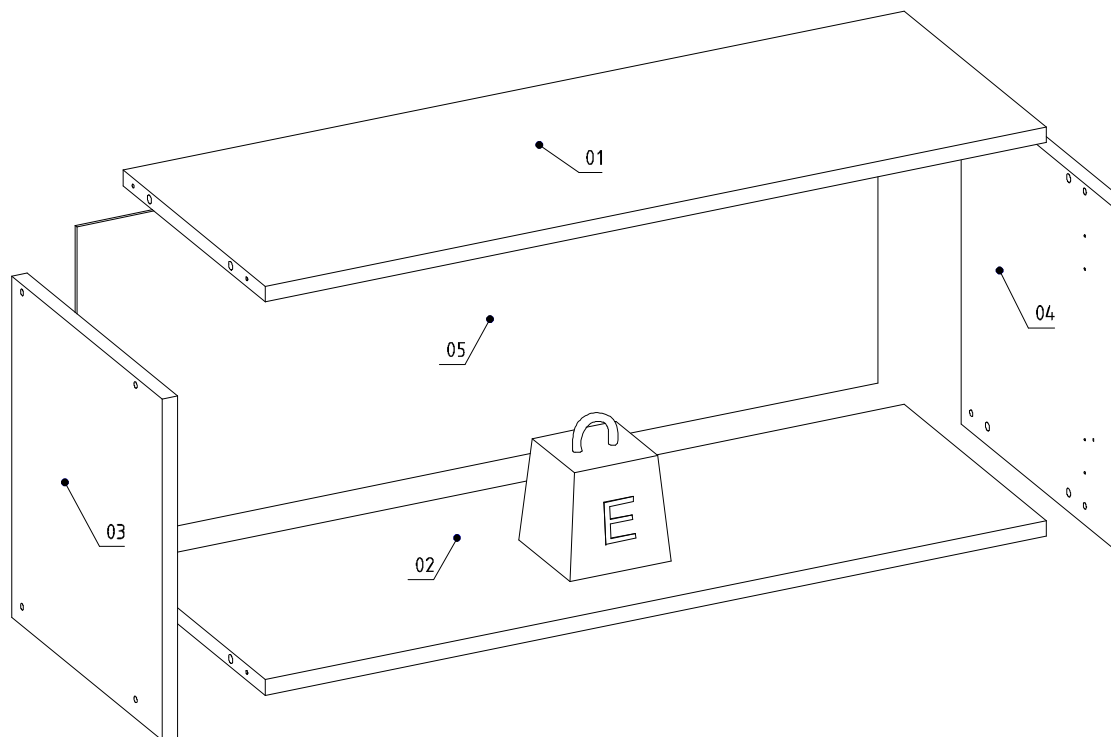

Nº	Measures_Inches	Medidas_cm	Qty./Qtd.
01	30 3/8 x 11 1/8 x 5/8	77.0 x 28.1 x 1.5	1
02	30 3/8 x 11 1/8 x 5/8	77.0 x 28.1 x 1.5	1
03	13 x 11 3/4 x 5/8	33.0 x 29.7 x 1.5	1
04	13 x 11 3/4 x 5/8	33.0 x 29.7 x 1.5	1
05	31 1/8 x 12 1/8 x 1/8	79.0 x 30.9 x 0.3	1

## IDENTIFICATION OF ACCESSORIES IDENTIFICAÇÃO DOS ACESSÓRIOS/ IDENTIFICACIÓN DE ACCESORIOS



The separation of the accessories before you start the assembly will facilitate the same. In case of doubt on the size of the screws and bolts, use the ruler at bottom of page.  
A separação dos acessórios antes de iniciar a montagem facilitará a mesma. Em caso de dúvida no tamanho dos parafusos e cavilhas, utilize a régua ao final da página.  
La separación de los accesorios antes de comenzar el armado facilitará el mismo. En caso de duda sobre el tamaño de los tornillos y taquetes, utilice la regla al pie de página.

A		Flanged head screw Parafuso flangeado / Tornillo de cabeza flangeada	5,0x90 mm	2
B3		Bushing Buchsa expansiva / Tapón	8x50 mm	2
E		Wooden dowel Cavilha / Taquete	8x30 mm	8
N		Nail Prego / Clavo	10x10	20
N5		Support "L" Soporte "L" / Soporte "L"	-	2
O		Flat head screw Parafuso abeto / Tornillo de cabeza plana	4,5x45 mm	8
S		Pan head screw Parafuso panela / Tornillo de pan	3,5x14 mm	16
S7A		Gas piston Pistão a gás / Pistón de gas	-	1
S7B		Side support piston Suporte pistão lateral / Soporte pistón lateral	-	1
S7C		Door support piston Suporte pistão porta / Soporte pistón puerta	-	1
S7D		Pan head screw Parafuso panela / Tornillo de pan	3,5x12 mm	5
Z13		Metal hinge straight Dobradiça reta / Bisagra recta	35 mm	2



### ATENÇÃO!

For hinged doors, the (M12) accessory and (S) fixing screws are supplied in the door package

Na configuração com portas de giro, o acessório (M12) e os demais parafusos de fixação (S) acompanham o produto no volume das portas

Para puertas batientes, el accesorio (M12) y los tornillos de fijación (S) se suministran en el bulto de las Puertas.

M12		Metal hinge super high Dobradiça super alta / Bisagra alta	35 mm	4
S		Pan head screw Parafuso panela / Tornillo de pan	3,5x14 mm	24



## PRE-ASSEMBLE PRÉ-MONTAGEM / PRE ARMADO

01

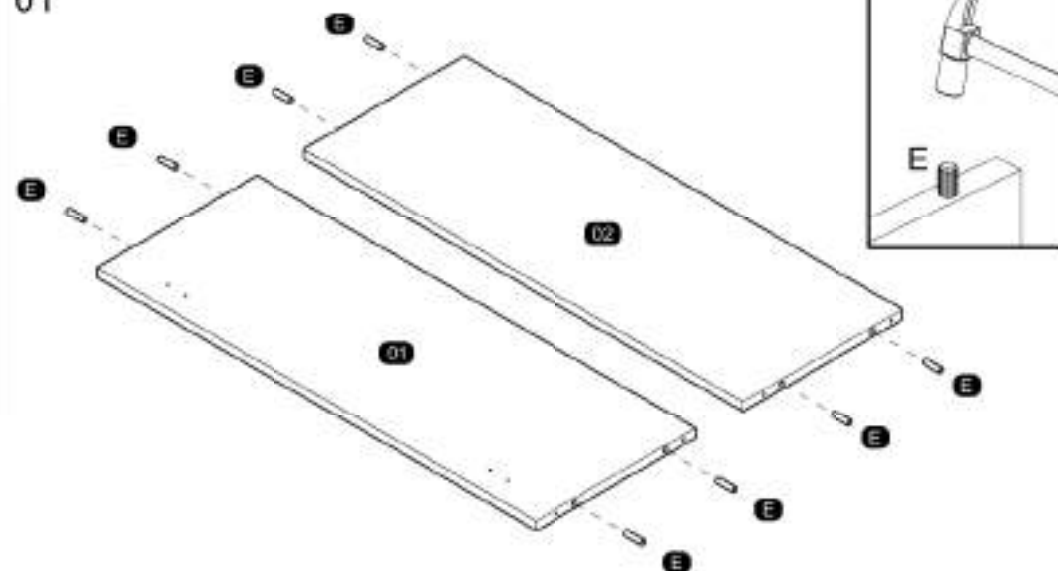

## ASSEMBLY MONTAGEM / ARMADO

02

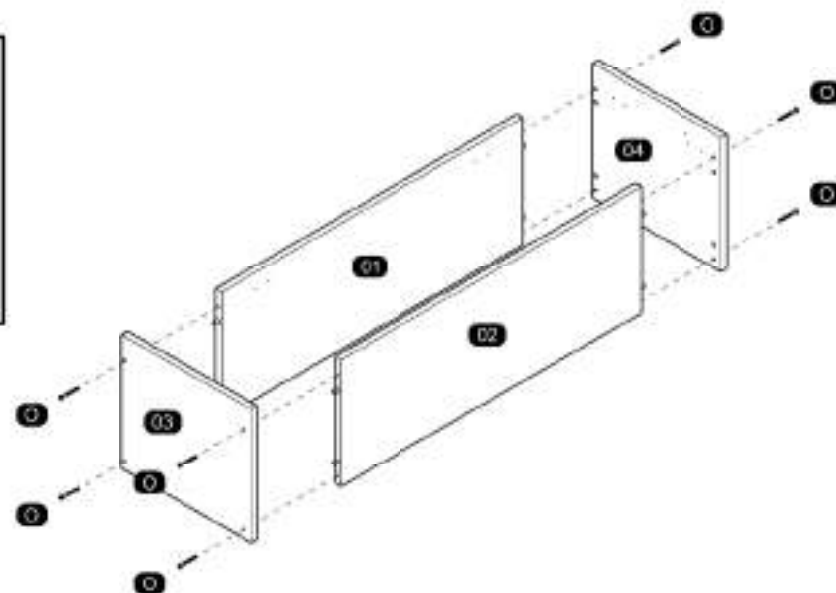
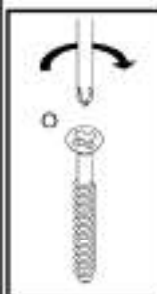

03

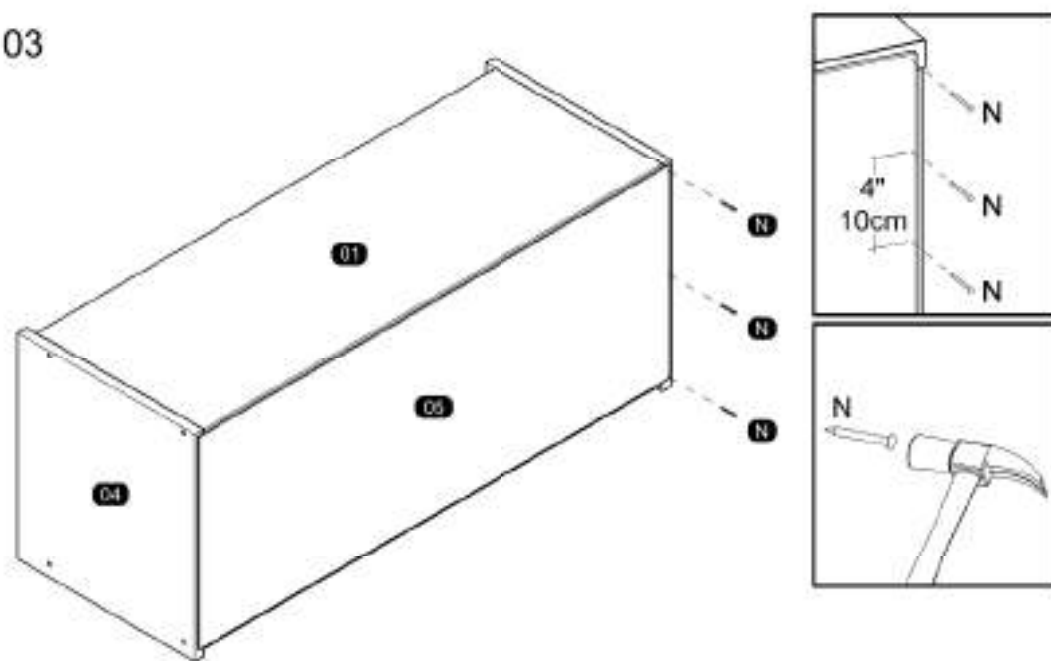

MOUNTING ON THE CHOSEN DOOR MODEL  
 MONTAGEM NO MODELO DE PORTA ESCOLHIDO / MONTAJE EN EL MODELO DE PUERTA ELEGIDO

05

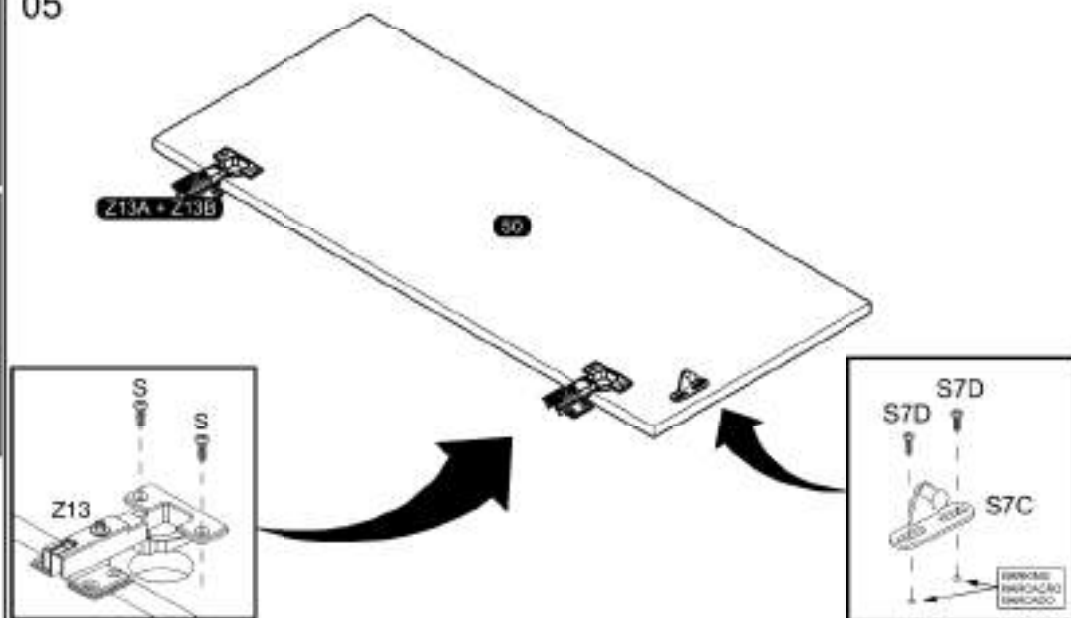

04

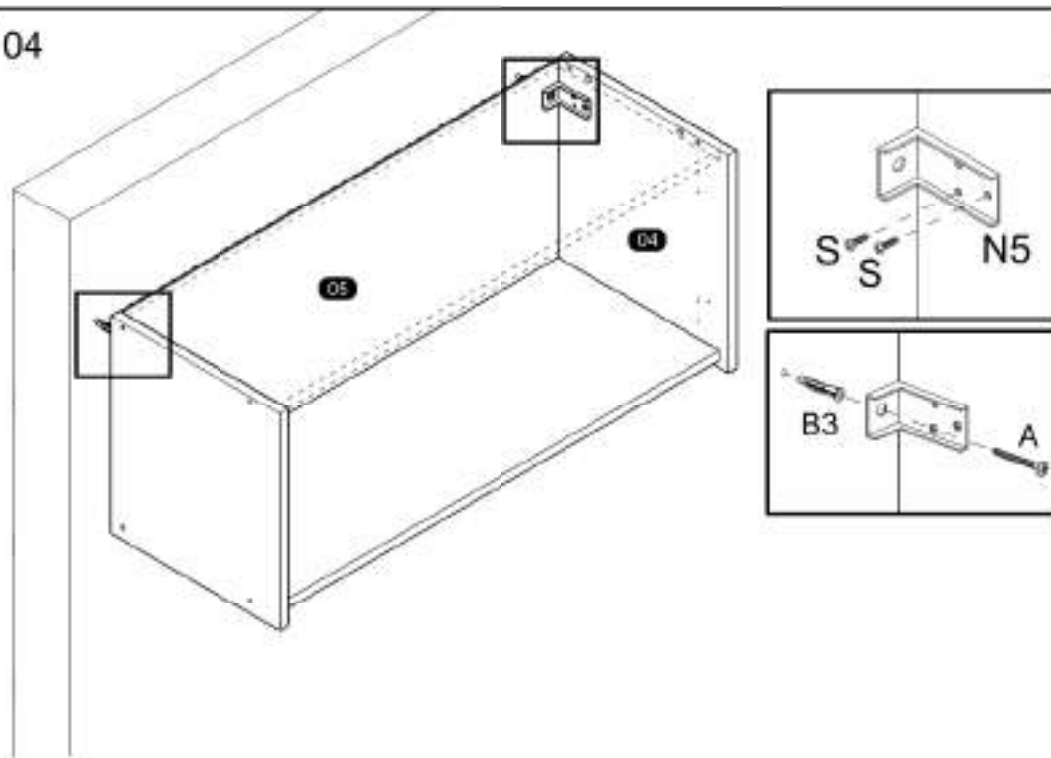

06

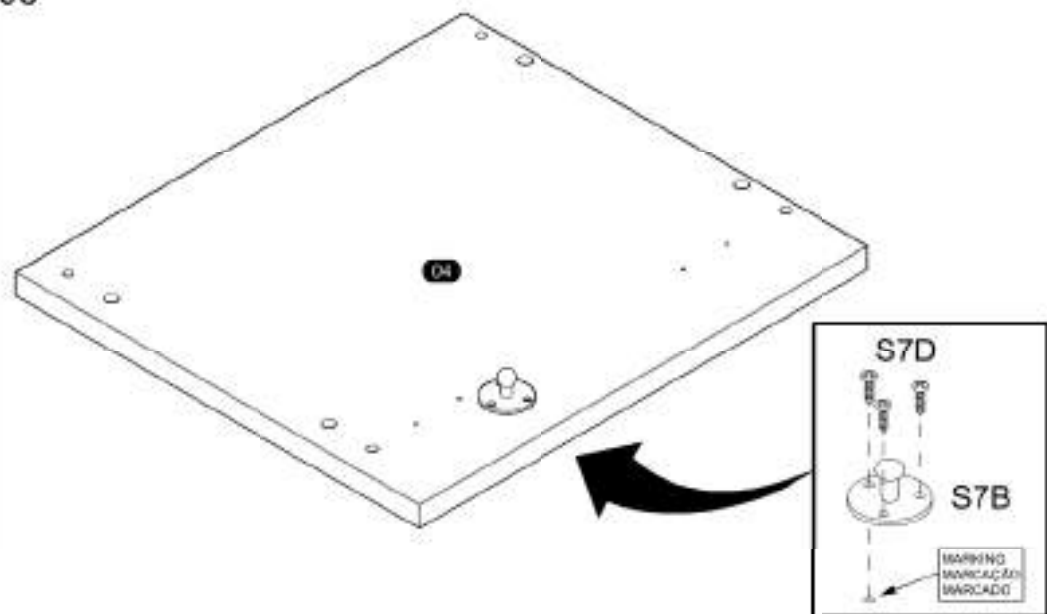

07

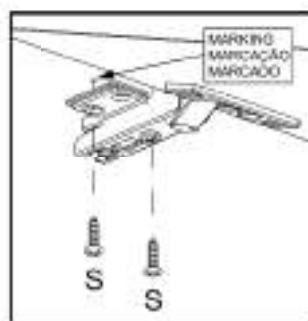
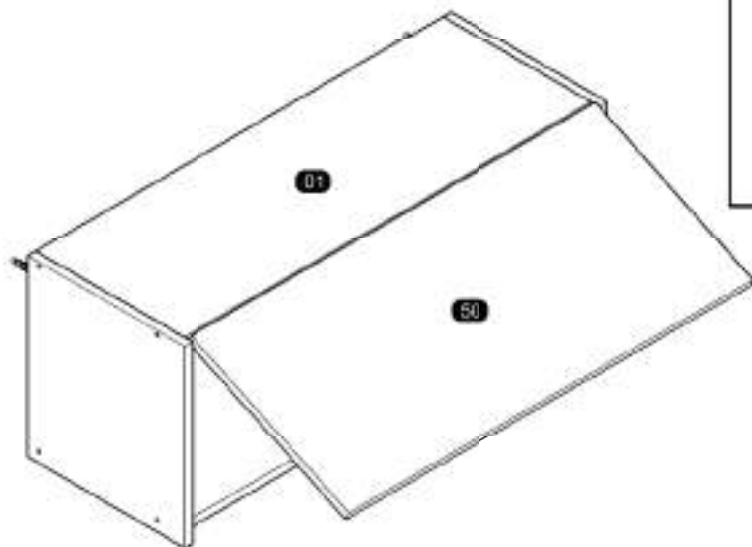

09

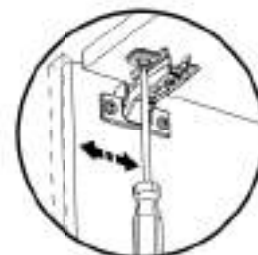
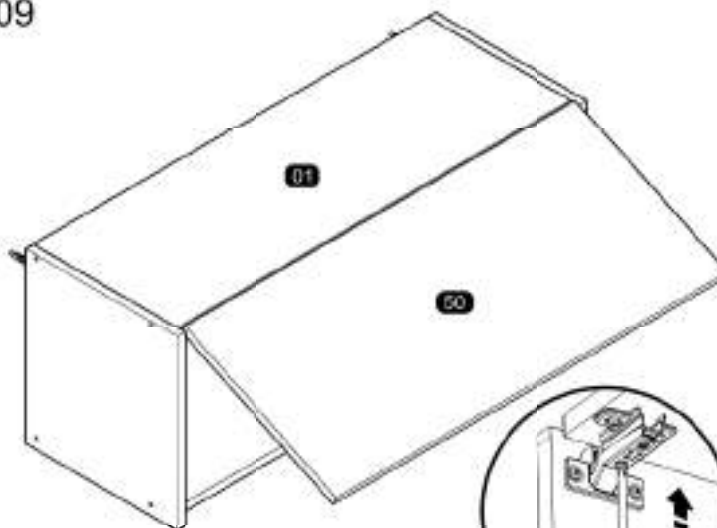

Horizontal Adjustment  
Regulagem Horizontal  
Ajuste Horizontal

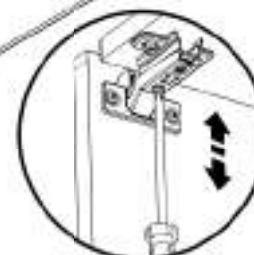

Vertical Adjustment  
Regulagem Vertical  
Ajuste Vertical



Depth Adjustment  
Regulagem Profundidade  
Ajuste Profundidade

08

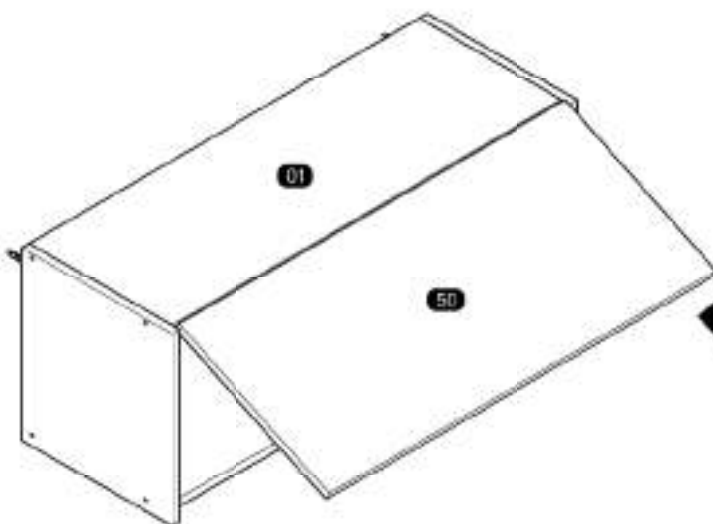

Follow the instruction corresponding to the template you received.  
Siga a instrução correspondente ao modelo que recebeu.  
Siga las instrucciones correspondientes al modelo que recibió.

Model 1 / Modelo 1



Model 2 / Modelo 2

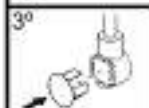

10

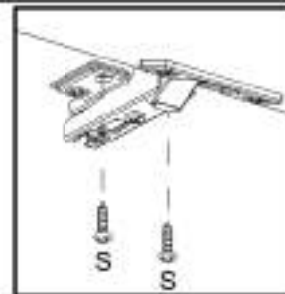
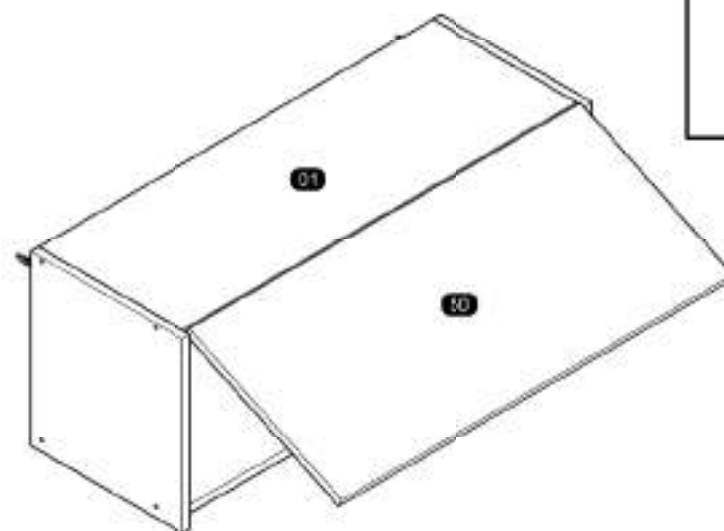

# ASSEMBLY INSTRUCTIONS MANUAL DE MONTAGEM / INSTRUCCIONES DE ARMADO

WALL CABINET 2 DOORS  
AEREO 2P  
ARMARIO DE PAREDE 2 PUERTAS

Reference  
Referência  
Referencia **260031** | Revise  
| Revisão  
| Revisión **00**

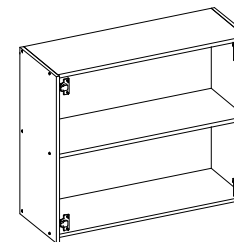

**YOU WILL NEED  
VOCÊ VAI PRECISAR DE / USTED NECESITARÁ**

Tools not supplied  
Ferramentas não fornecidas / Herramientas no incluidas

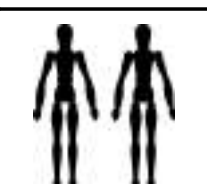

2 People  
2 Pessoas  
2 Personas

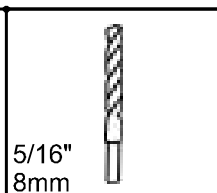

Drill bit  
Broca  
Taladro

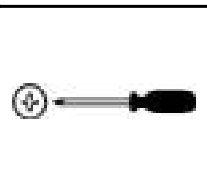

Screwdriver Phillips  
Chave Phillips  
Destornillador cruz



Drill machine  
Furadeira  
Taladro

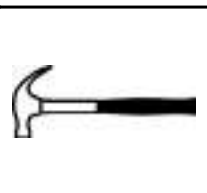

Hammer  
Martelo  
Martillo

 MAXIMUM RECOMMENDED WEIGHT BEING THIS EVENLY DISTRIBUTED.  
PESO MÁXIMO RECOMENDADO SENDO ESTE DISTRIBUÍDO UNIFORMEMENTE.  
PESO MÁXIMO RECOMENDADO SIENDO ESTE UNIFORMEMENTE DISTRIBUIDO.

	LB	KG
F	22	10

**PARTS IDENTIFICATION  
IDENTIFICAÇÃO DAS PEÇAS / IDENTIFICACIÓN DE LAS PIEZAS**

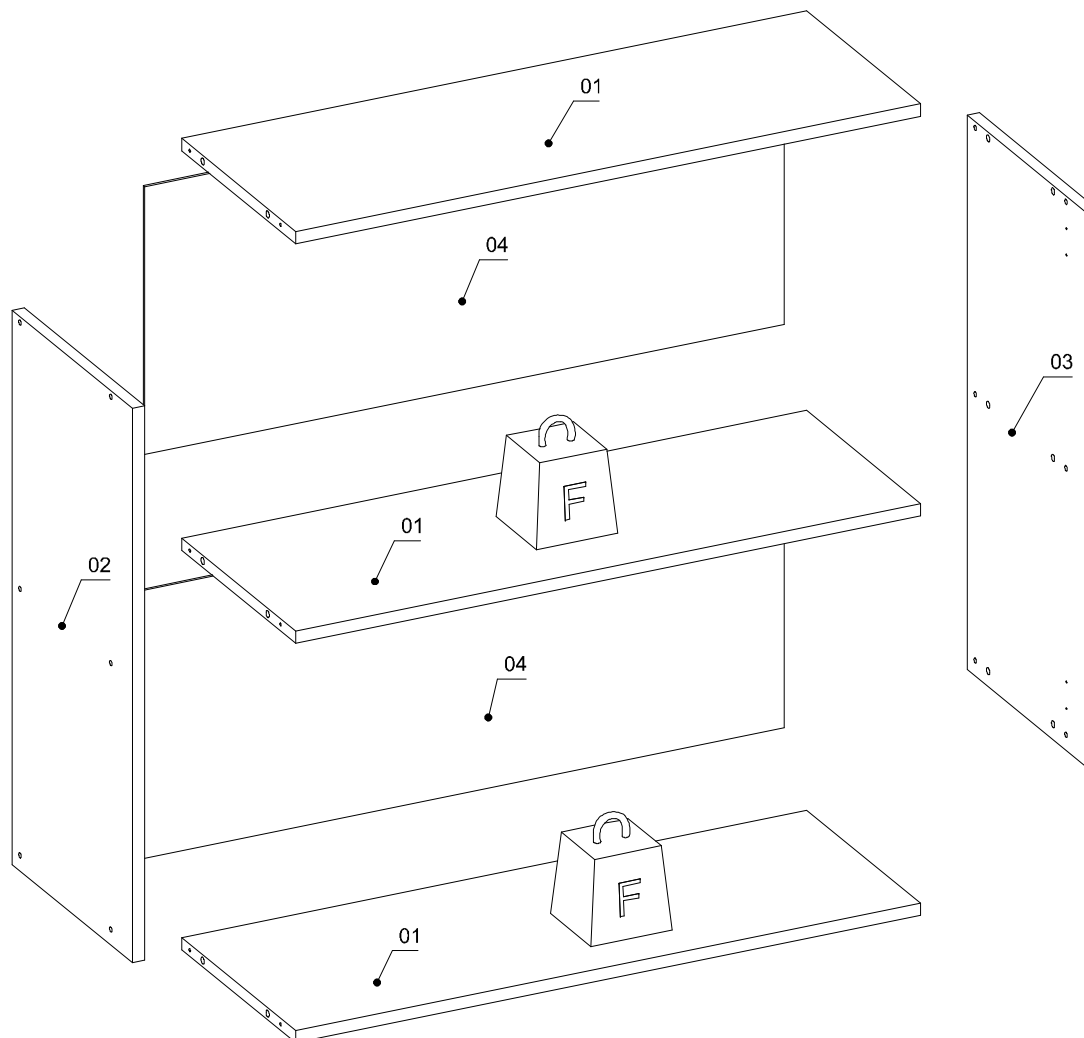

Nº	Measures_Inches	Medidas_cm	Qty./Qtd.
01	30 3/8 x 11 1/8 x 5/8	77.0 x 28.1 x 1.5	3
02	26 3/8 x 11 3/4 x 5/8	67.0 x 29.7 x 1.5	1
03	26 3/8 x 11 3/4 x 5/8	67.0 x 29.7 x 1.5	1
04	31 x 12 3/4 x 1/8	78.8 x 32.4 x 0.3	2

## IDENTIFICATION OF ACCESSORIES IDENTIFICAÇÃO DOS ACESSÓRIOS/ IDENTIFICACIÓN DE ACCESORIOS



The separation of the accessories before you start the assembly will facilitate the same. In case of doubt on the size of the screws and bolts, use the ruler at bottom of page.  
 A separação dos acessórios antes de iniciar a montagem facilitará a mesma. Em caso de dúvida no tamanho dos parafusos e cavilhas, utilize a régua ao final da página.  
 La separación de los accesorios antes de comenzar el armado facilitará el mismo. En caso de duda sobre el tamaño de los tornillos y taquetes, utilice la regla al pie de página.

A		Flanged head screw Parafuso flangeado / Tornillo de cabeza flangeada	5,0x90 mm	2
B3		Bushing Buchsa expansiva / Tapón	8x50 mm	2
C1		Metal claw Garras de metal / Garras metal	-	5
E		Wooden dowel Cavilha / Taquete	8x30 mm	12
M12		Metal hinge super light Dobradiza super alba / Bisagra alba	35 mm	4
N		Nail Prego / Clavo	10x10	37
N5		Support "L" Soporte "L" / Soporte "L"	-	2
O		Flat head screw Parafuso chato / Tornillo de cabeza plana	4,5x40 mm	12
S		Pan head screw Parafuso panel / Tornillo de pan	3,5x14 mm	28



## PRE-ASSEMBLE PRÉ-MONTAGEM / PRE ARMADO

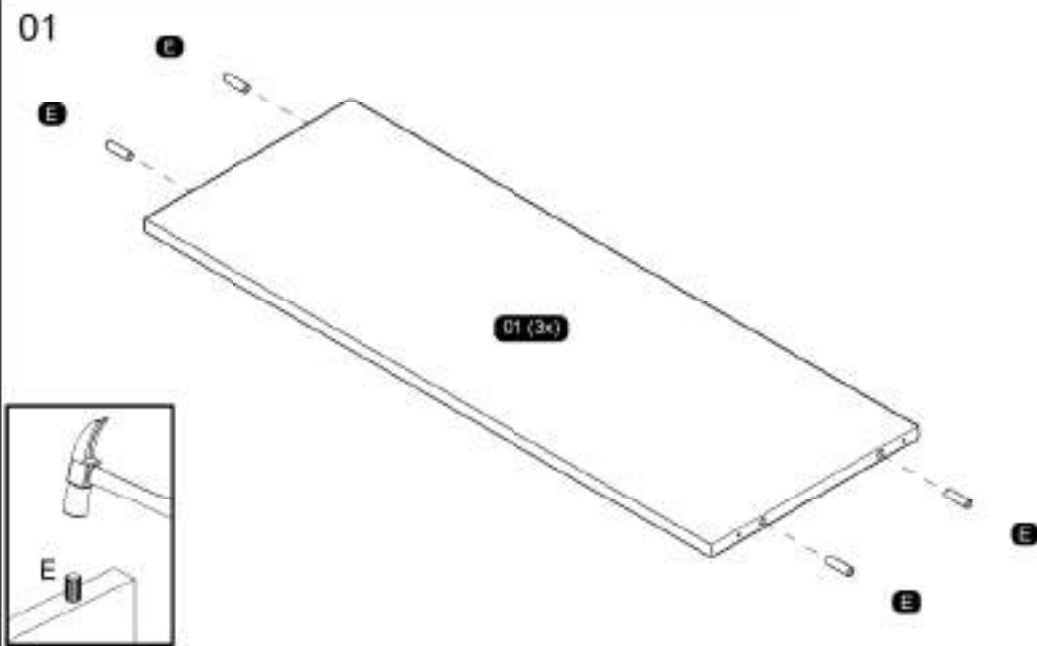

## PRE-ASSEMBLE PRÉ-MONTAGEM / PRE ARMADO

**02**

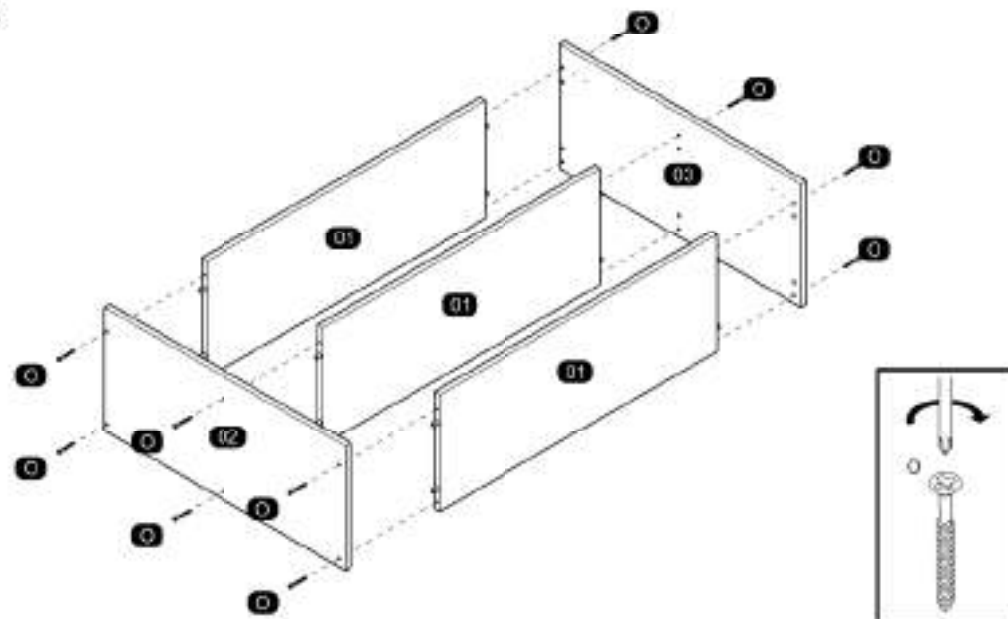

**03**

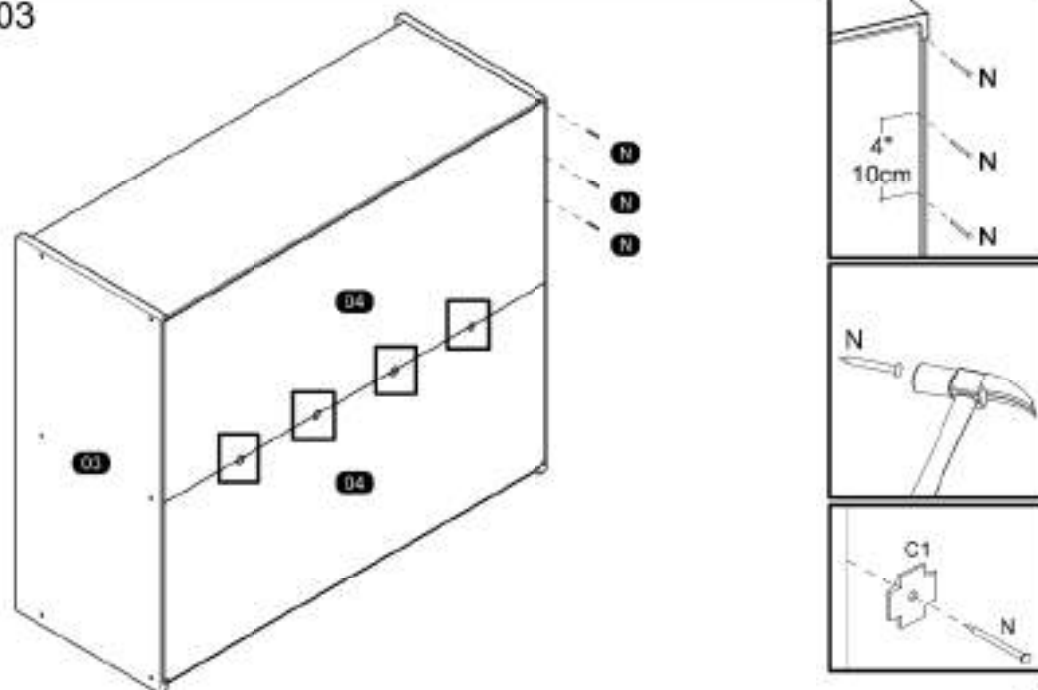

04

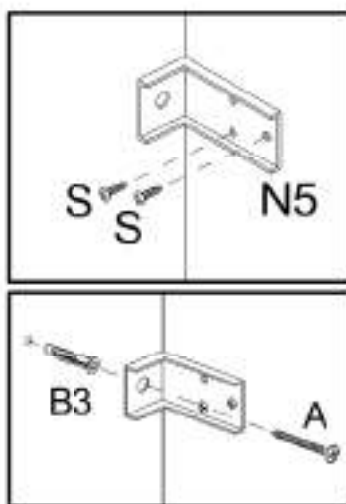
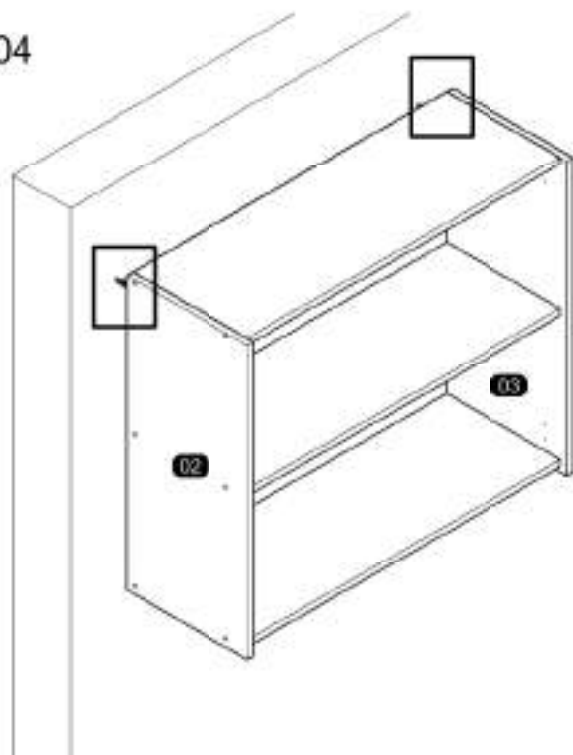

06

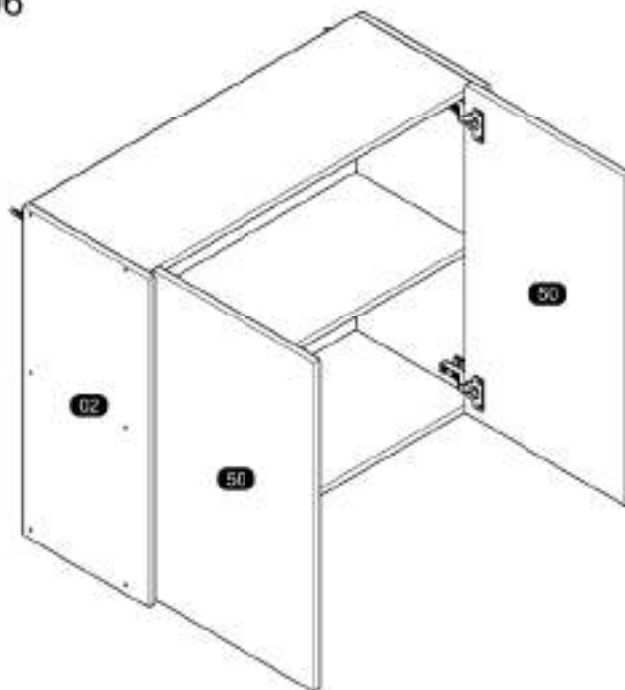

05

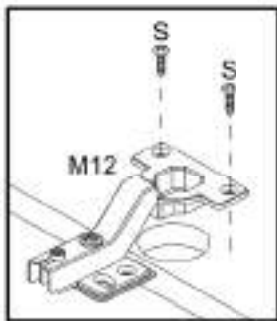
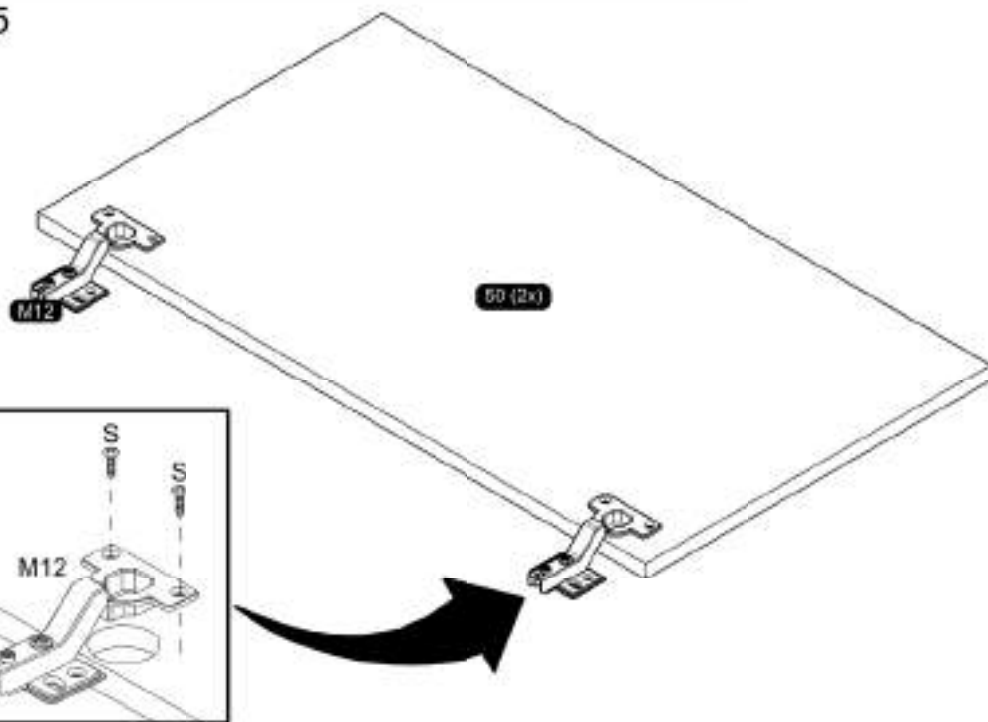

07

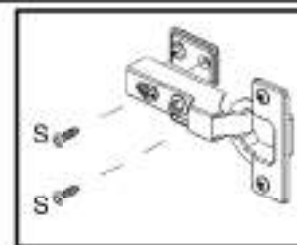
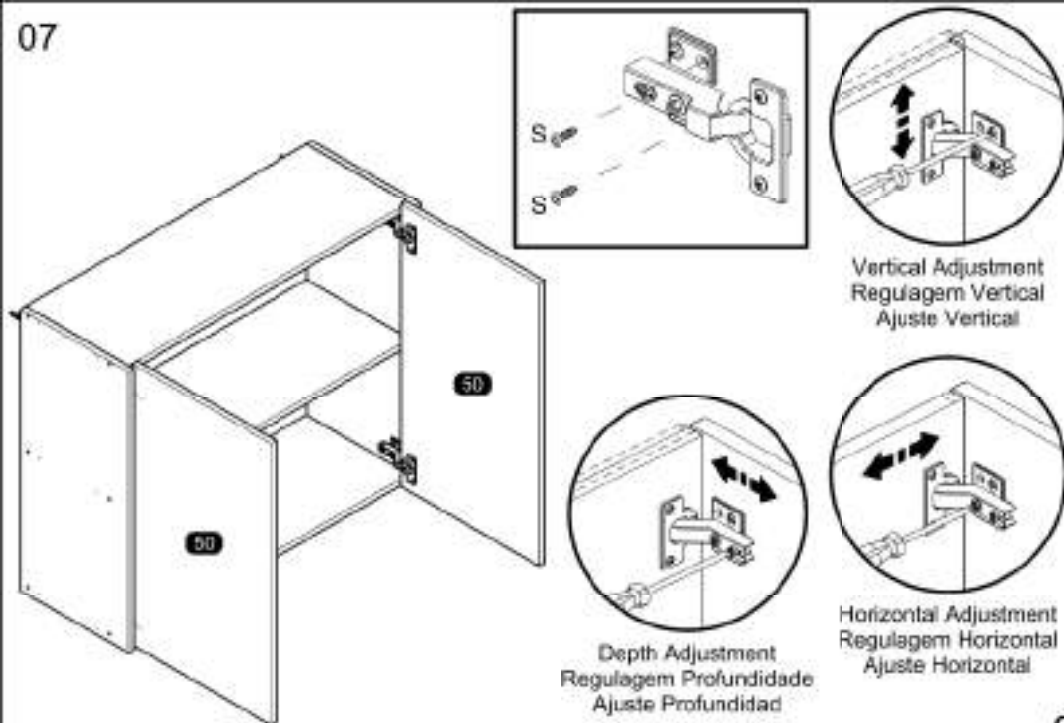

Vertical Adjustment  
Regulagem Vertical  
Ajuste Vertical

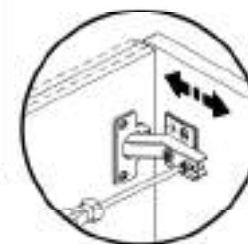

Depth Adjustment  
Regulagem Profundidade  
Ajuste Profundidad



Horizontal Adjustment  
Regulagem Horizontal  
Ajuste Horizontal

# ASSEMBLY INSTRUCTIONS MANUAL DE MONTAGEM / INSTRUCCIONES DE ARMADO

CAMPANELE 4 DOORS GLASS DISPLAY CABINET  
CRISTALEIRA 4P DE VIDRO CAMPANELE  
VITRINA CAMPANELE 4 PUERTAS DE VIDRO

Reference  
Referência  
Referencia **260029** | Revise  
| Revisão  
| Revisión **00**

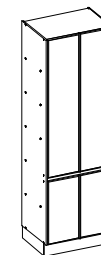

### YOU WILL NEED VOCÊ VAI PRECISAR DE / USTED NECESITARÁ

Tools not supplied  
Ferramentas não fornecidas / Herramientas no incluidas

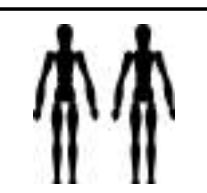

2 People  
2 Pessoas  
2 Personas

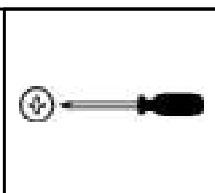

Screwdriver Phillips  
Chave Phillips  
Destornillador cruz

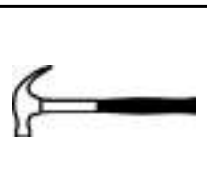

Hammer  
Martelo  
Martillo



MAXIMUM RECOMMENDED WEIGHT  
BEING THIS EVENLY DISTRIBUTED.

PESO MÁXIMO RECOMENDADO SENDO  
ESTE DISTRIBUÍDO UNIFORMEMENTE.

PESO MÁXIMO RECOMENDADO SIENDO  
ESTE UNIFORMEMENTE DISTRIBUIDO.

	LB	KG
—		
F	22	10

### PARTS IDENTIFICATION IDENTIFICAÇÃO DAS PEÇAS / IDENTIFICACIÓN DE LAS PIEZAS

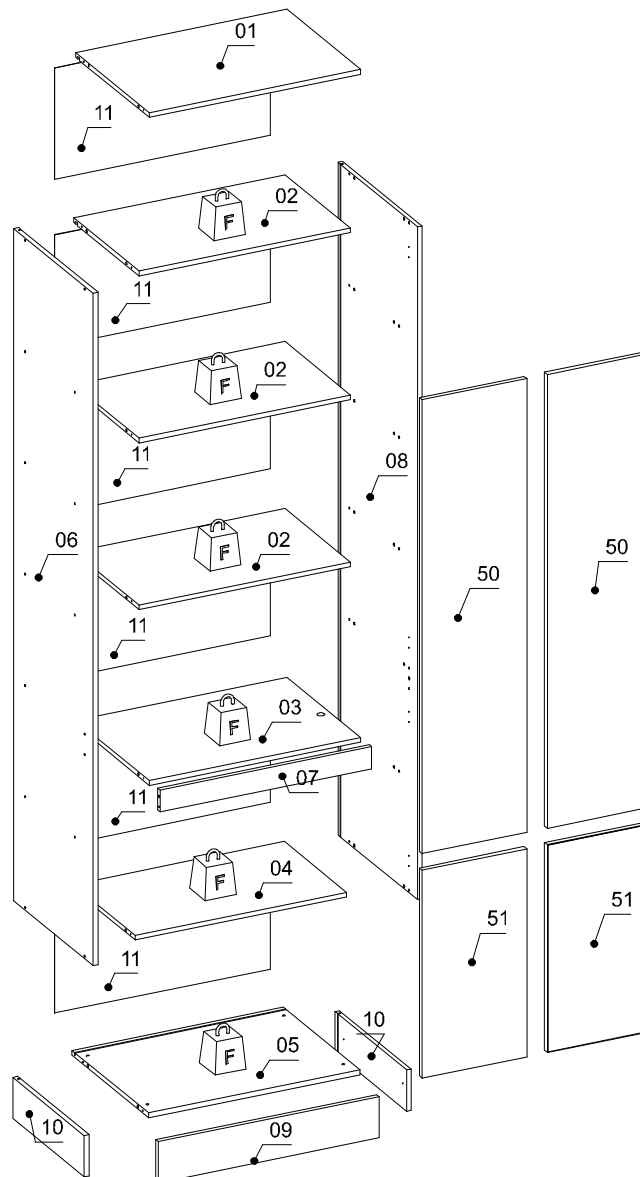

Nº	Measures_Inches	Medidas_cm	Qty./Qtd.
01	26 3/4 x 18 5/8 x 5/8	68.0 x 47.4 x 1.5	1
02	26 3/4 x 16 1/2 x 5/8	68.0 x 42.0 x 1.5	3
03	26 3/4 x 18 5/8 x 5/8	68.0 x 47.4 x 1.5	1
04	26 3/4 x 15 3/4 x 5/8	68.0 x 40.0 x 1.5	1
05	26 3/4 x 19 3/8 x 5/8	68.0 x 49.3 x 1.5	1
06	83 1/2 x 20 1/8 x 5/8	212.0 x 51.0 x 1.5	1
07	26 3/4 x 2 3/4 x 5/8	68.0 x 7.0 x 1.5	1
08	83 1/2 x 20 1/8 x 5/8	212.0 x 51.0 x 1.5	1
09	28 x 5 1/8 x 5/8	71.0 x 13.0 x 1.5	1
10	18 1/8 x 5 1/8 x 5/8	45.9 x 13.0 x 1.5	2
11	27 3/8 x 13 3/4 x 1/8	69.4 x 35.0 x 0.3	6
50	56 3/8 x 13 1/4 x 3/4	143.1 x 33.6 x 1.8	2
51	25 3/4 x 13 1/4 x 3/4	65.5 x 33.6 x 1.8	2

## IDENTIFICATION OF ACCESSORIES IDENTIFICAÇÃO DOS ACESSÓRIOS/ IDENTIFICACIÓN DE ACCESORIOS



The separation of the accessories before you start the assembly will facilitate the same. In case of doubt on the size of the screws and bolts, use the ruler at bottom of page.  
A separação dos acessórios antes de iniciar a montagem facilitará a mesma. Em caso de dúvida no tamanho dos parafusos e cavilhas, utilize a régua ao final da página.  
La separación de los accesorios antes de comenzar el armado facilitará el mismo. En caso de duda sobre el tamaño de los tornillos y taquetes, utilice la regla al pie de página.

A8		Flat head screw Parafuso chato / Tornillo de cabeza plana	3,5x20 mm	13
C1		Metal claw Garra de metal / Gama metal	-	15
E		Wooden dowel Cavilha / Taquete	8x30 mm	30
E4		Mirror support Suporte espelho / Soporte espejo	-	2
L1		Flat head screw Parafuso chato / Tornillo de cabeza plana	7,5x40 mm	4
L3		Plastic Foot Soporo / Pie Plástico	-	4
M12		Metal hinge super tight Ombraçãca super alta / Bisagra alta	35 mm	8
N		Nail Prego / Clavo	10x10	19
N4		Loop Presilha / Presilla	-	6
N24A		Electrical cable part 1 Chicote eléctrico parte 1 / Cable eléctrico parte 1	-	4
N24B		Switch Interruptor / Interruptor	-	1
N24C		Electrical cable part 2 Chicote eléctrico parte 2 / Cable eléctrico parte 2	-	1
N24D		Electrical cable part 3 Chicote eléctrico parte 3 / Cable eléctrico parte 3	-	1
O		Flat head screw Parafuso chato / Tornillo de cabeza plana	4,5x45 mm	30
O1		Triangular support Suporte triangular / Soporte triangular	-	13
S		Pan head screw Parafuso panela / Tornillo de pan	3,5x14 mm	56



## PRE-ASSEMBLE PRÉ-MONTAGEM / PRE ARMADO

01

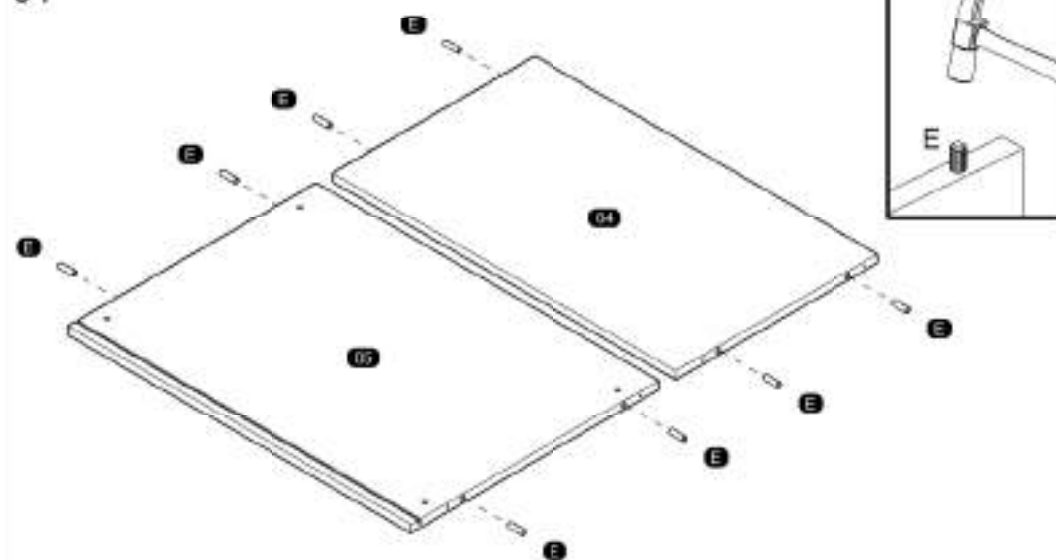

02

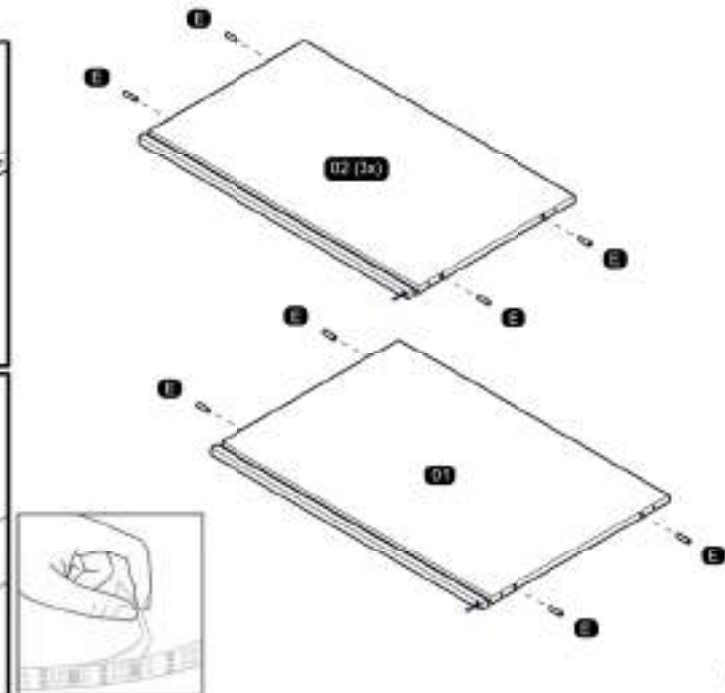
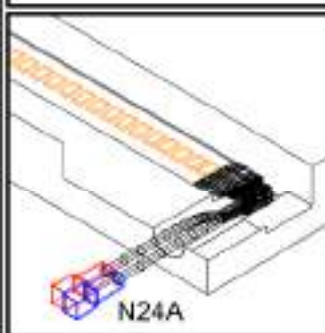
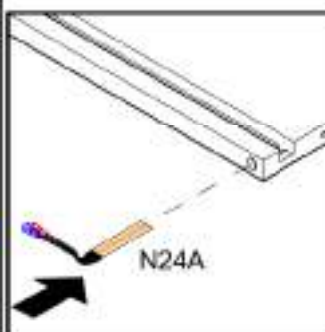

03

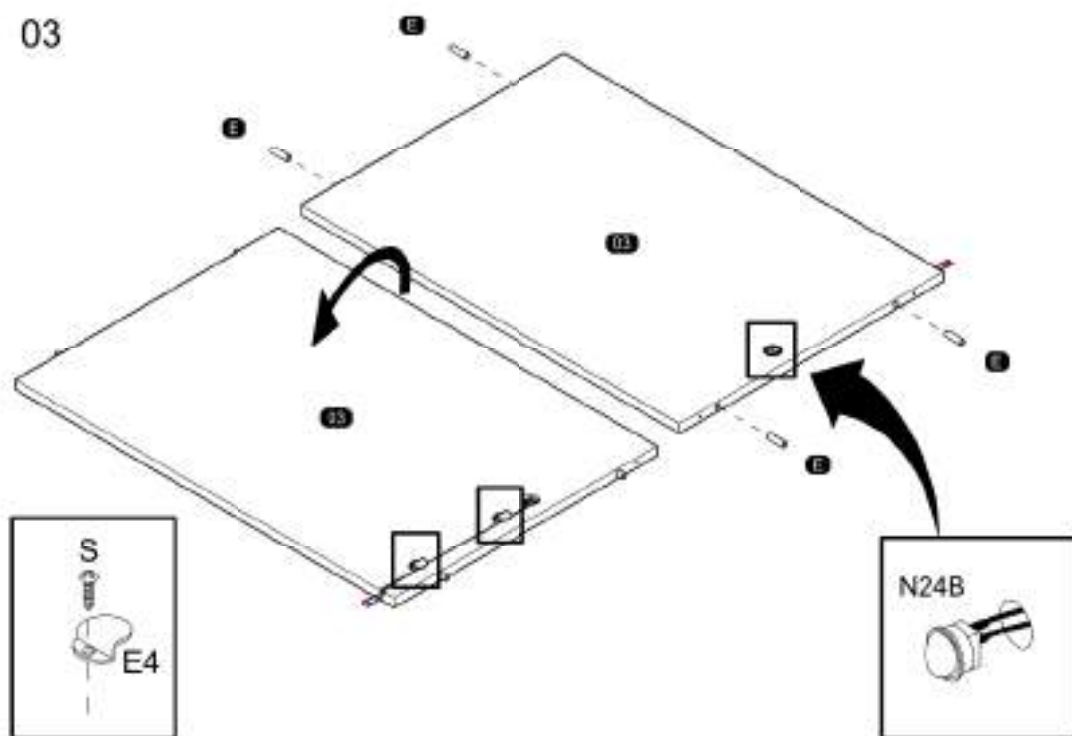

04

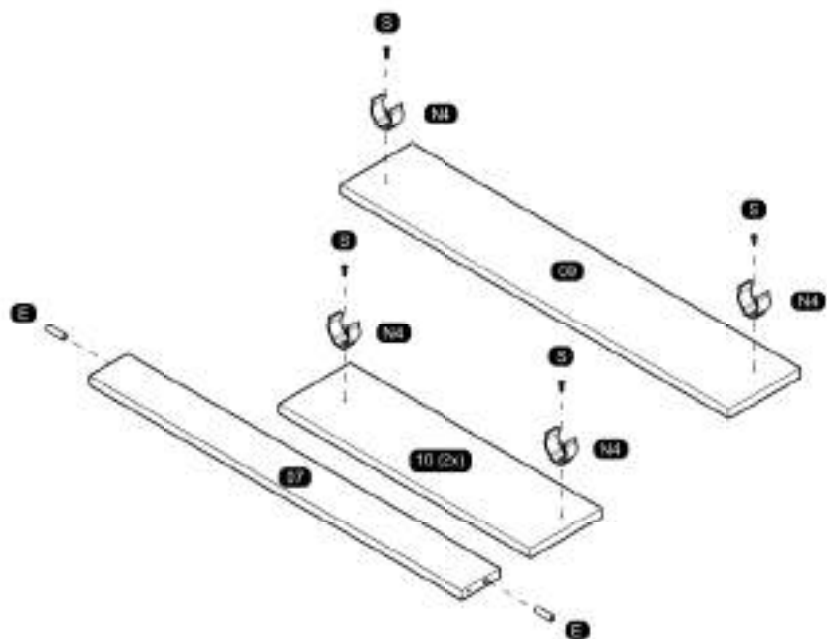

## ASSEMBLY MONTAGEM / ARMADO

05

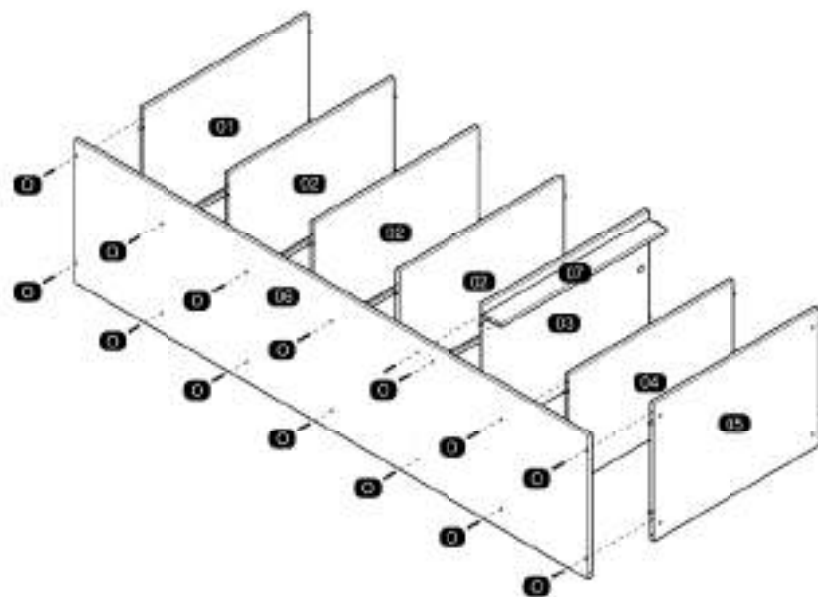

06

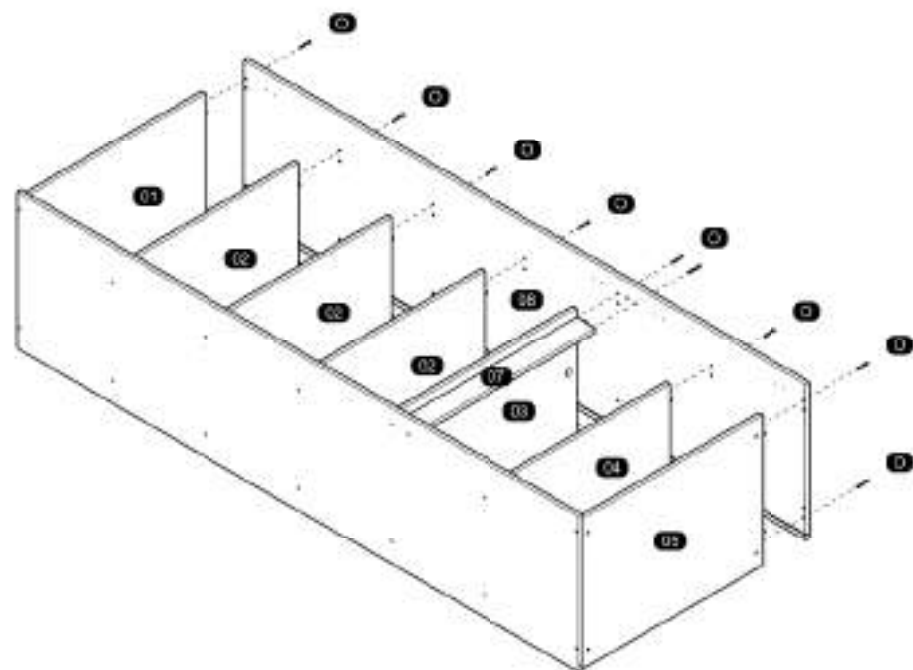

07

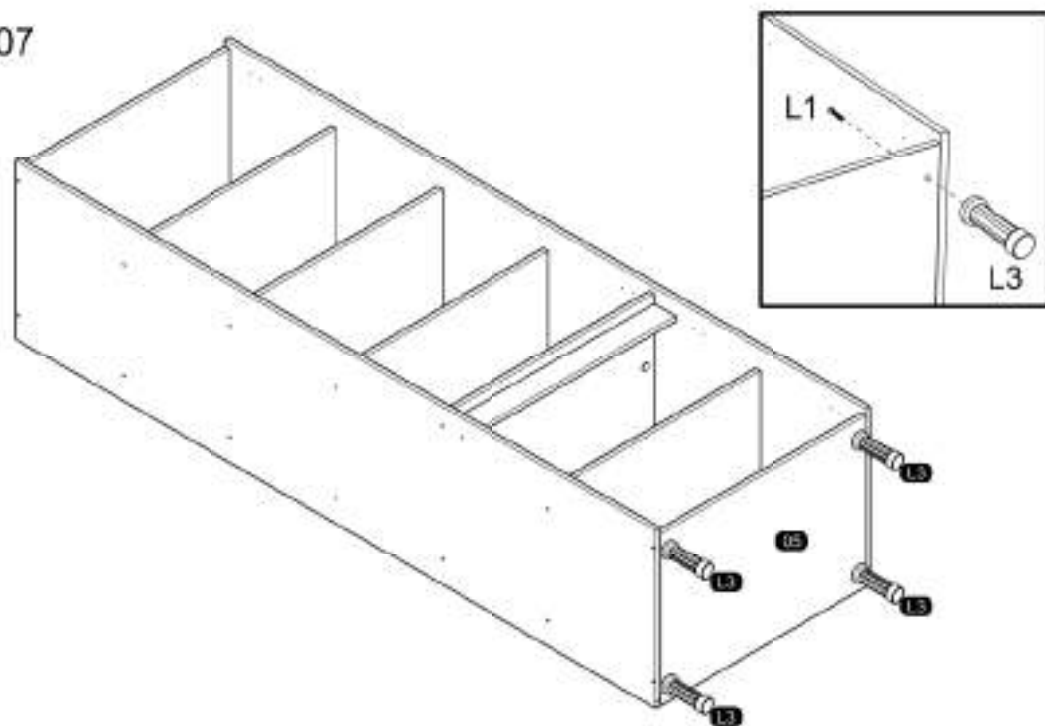

09

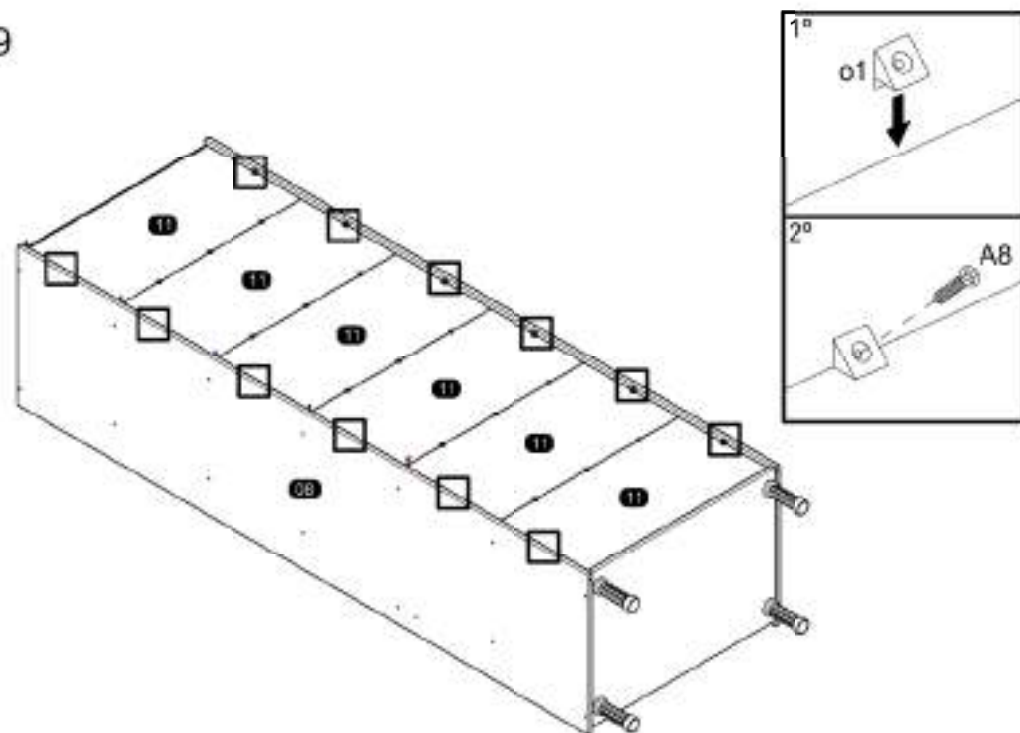

08

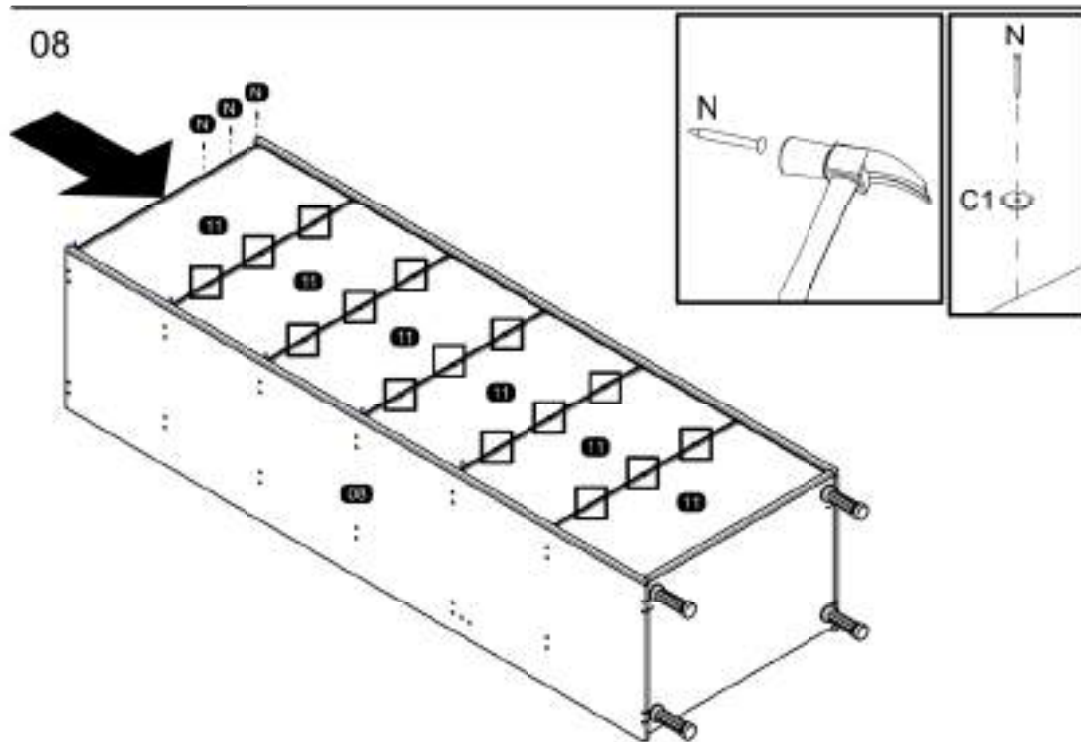

10

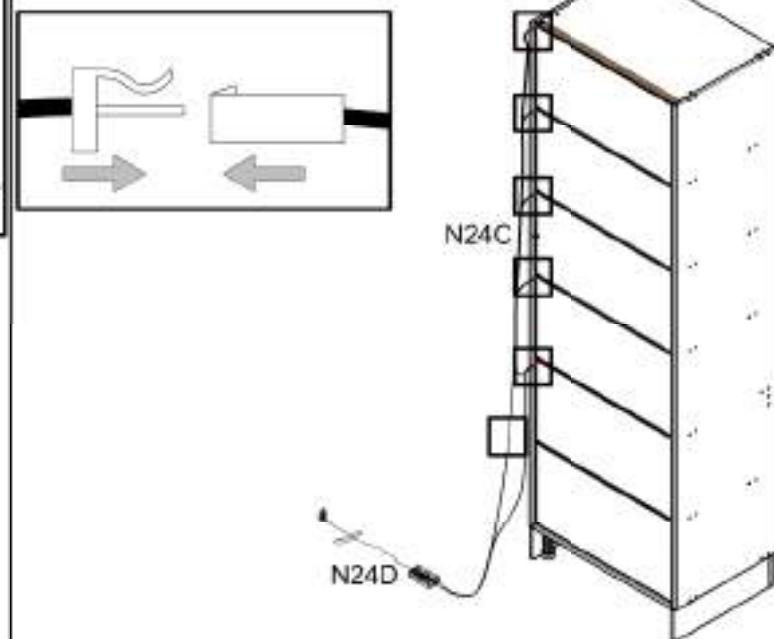

11

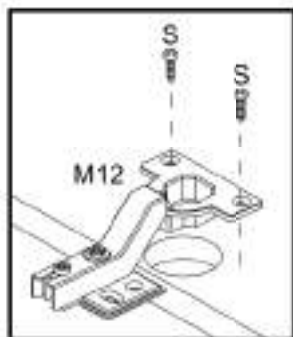
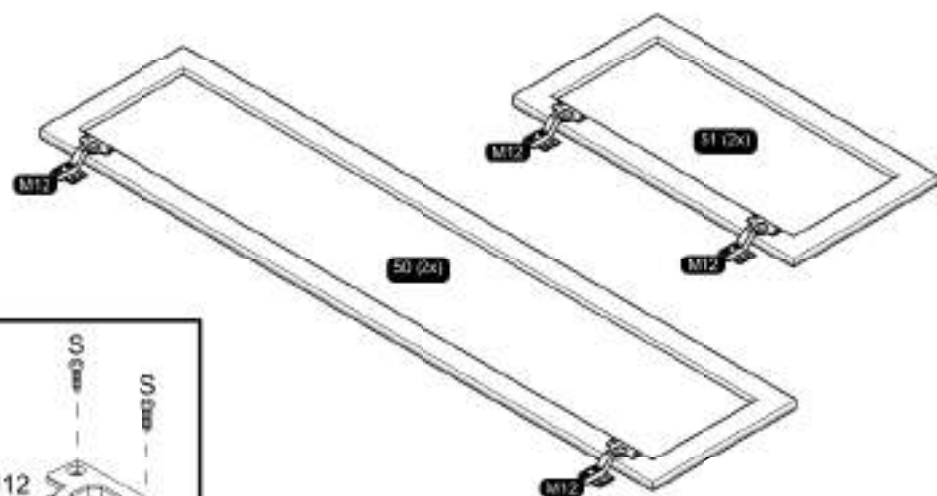

13

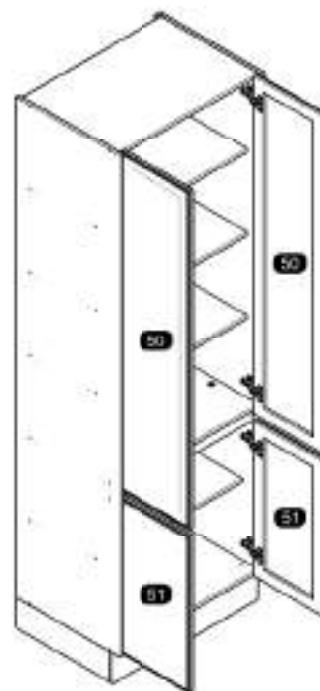

Horizontal Adjustment  
Regulagem Horizontal  
Ajuste Horizontal



Depth Adjustment  
Regulagem Profundidade  
Ajuste Profundidade



Vertical Adjustment  
Regulagem Vertical  
Ajuste Vertical

12

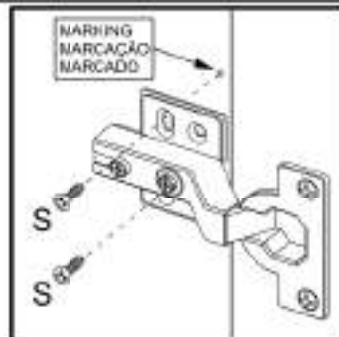
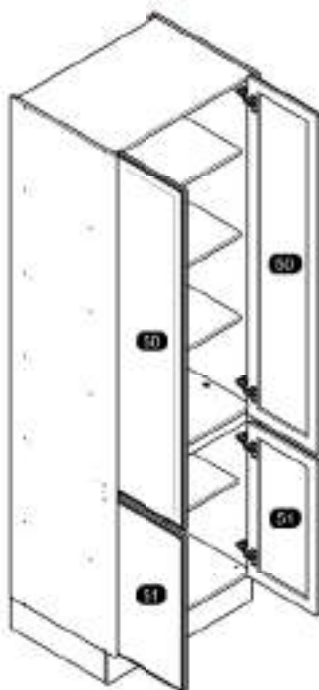

14

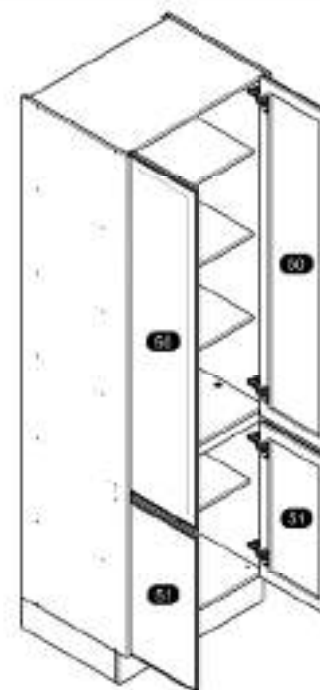

## IDENTIFICATION OF ACCESSORIES IDENTIFICAÇÃO DOS ACESSÓRIOS/ IDENTIFICACIÓN DE ACCESORIOS



The separation of the accessories before you start the assembly will facilitate the same. In case of doubt on the size of the screws and bolts, use the ruler at bottom of page.  
A separação dos acessórios antes de iniciar a montagem facilitará a mesma. Em caso de dúvida no tamanho dos parafusos e cavilhas, utilize a régua ao final da página.  
La separación de los accesorios antes de comenzar el armado facilitará el mismo. En caso de duda sobre el tamaño de los tornillos y taquetes, utilice la regla al pie de página.

A8		Flat head screw Parafuso chato / Tornillo de cabeza plana	3,5x20 mm	13
C1		Metal claw Garra de metal / Gama metal	-	15
E		Wooden dowel Cavilha / Taquete	8x30 mm	30
E4		Mirror support Suporte espelho / Soporte espejo	-	2
L1		Flat head screw Parafuso chato / Tornillo de cabeza plana	7,5x40 mm	4
L3		Plastic Foot Soporo / Pie Plástico	-	4
M12		Metal hinge super tight Ombraçãca super alta / Bisagra alta	35 mm	8
N		Nail Prego / Clavo	10x10	19
N4		Loop Presilha / Presilla	-	6
N24A		Electrical cable part 1 Chicote eléctrico parte 1 / Cable eléctrico parte 1	-	4
N24B		Switch Interruptor / Intermuplor	-	1
N24C		Electrical cable part 2 Chicote eléctrico parte 2 / Cable eléctrico parte 2	-	1
N24D		Electrical cable part 3 Chicote eléctrico parte 3 / Cable eléctrico parte 3	-	1
O		Flat head screw Parafuso chato / Tornillo de cabeza plana	4,5x45 mm	30
o1		Triangular support Suporte triangular / Soporte triangular	-	13
S		Pan head screw Parafuso panela / Tornillo de pan	3,5x14 mm	56



## PRE-ASSEMBLE PRÉ-MONTAGEM / PRE ARMADO

01

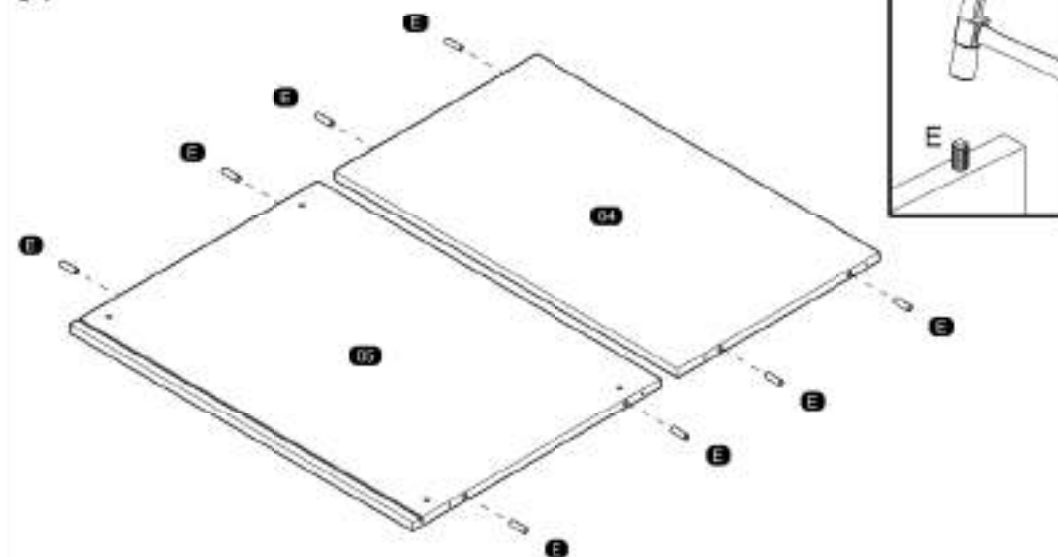

02

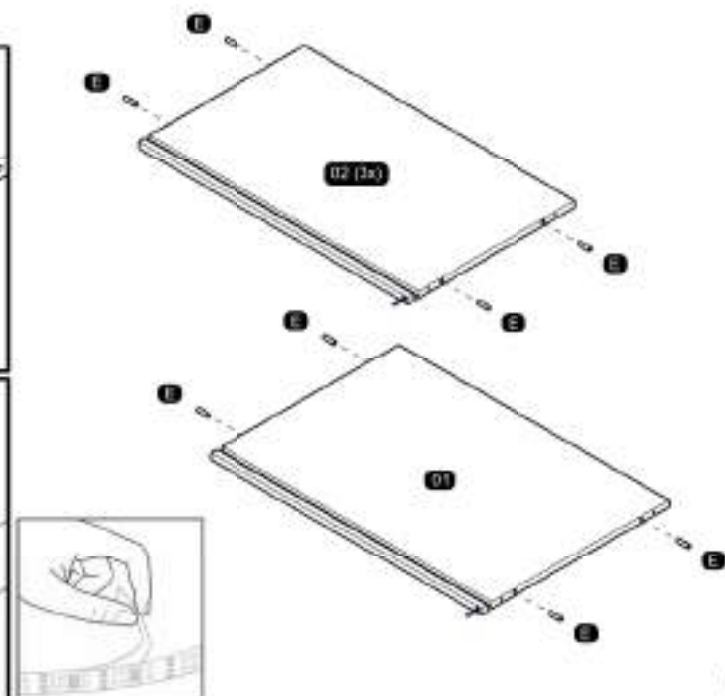
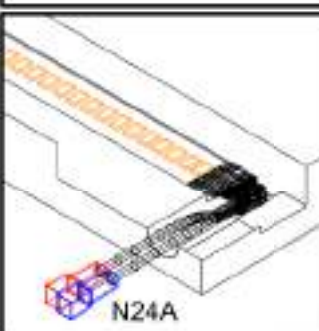
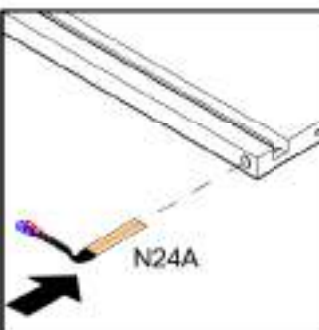

03

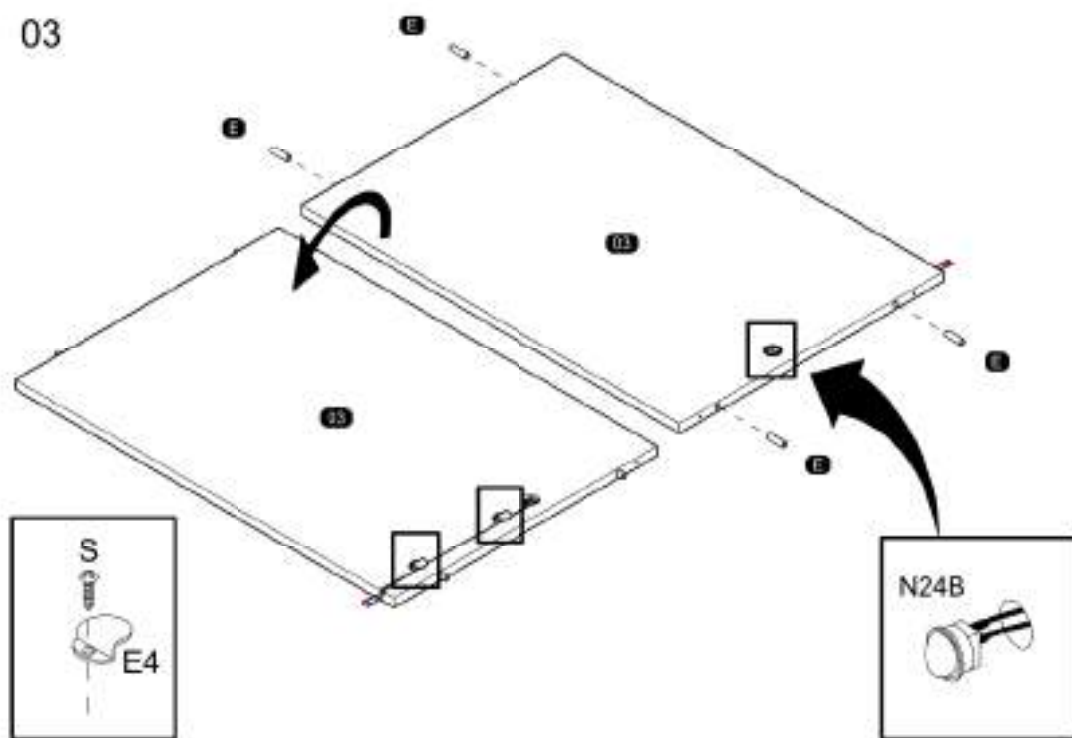

04

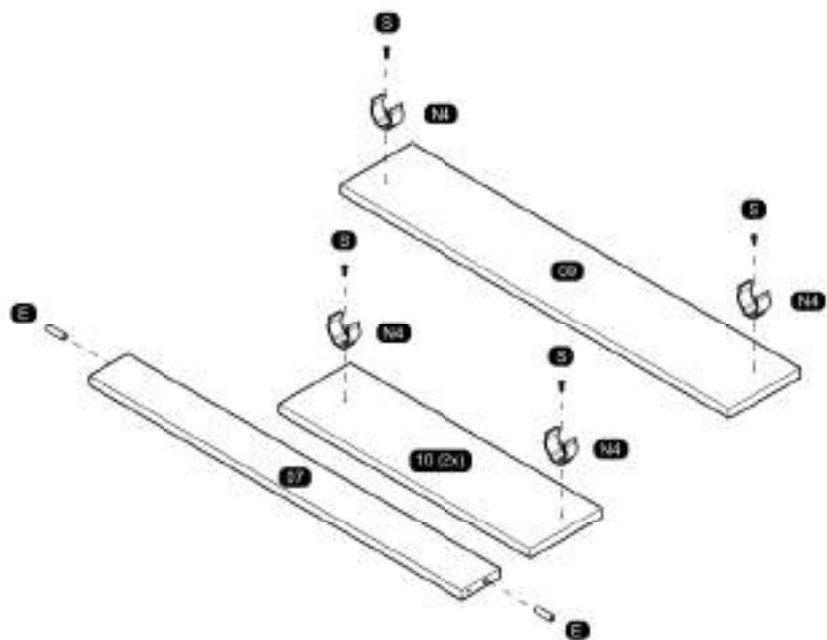

## ASSEMBLY MONTAGEM / ARMADO

05

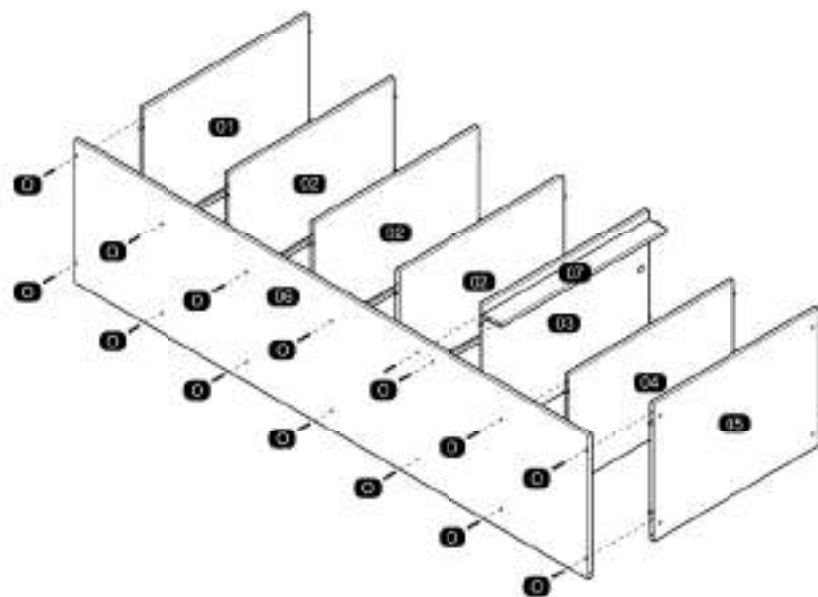

06

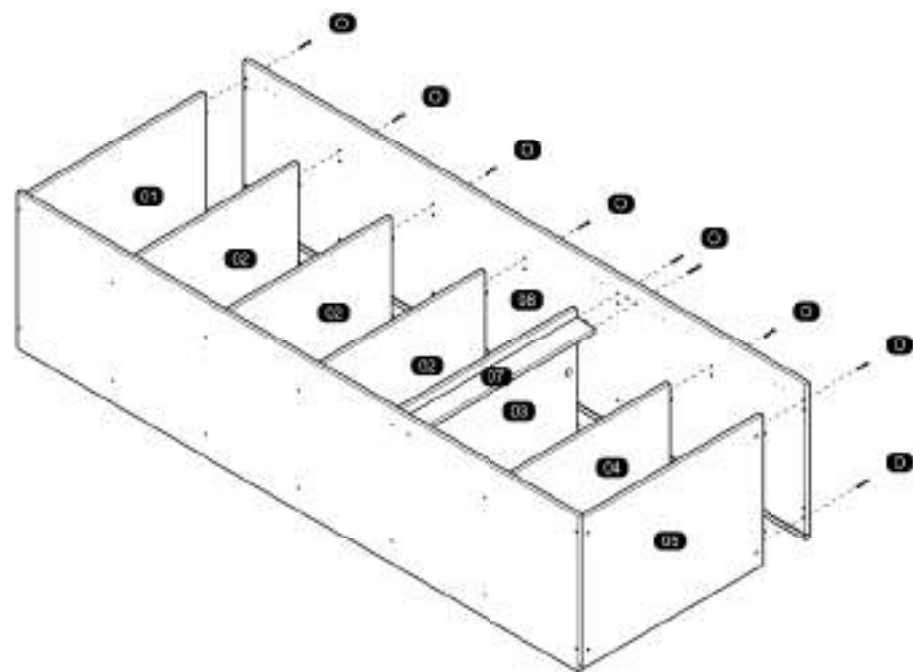

11

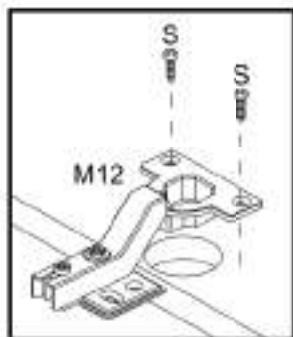
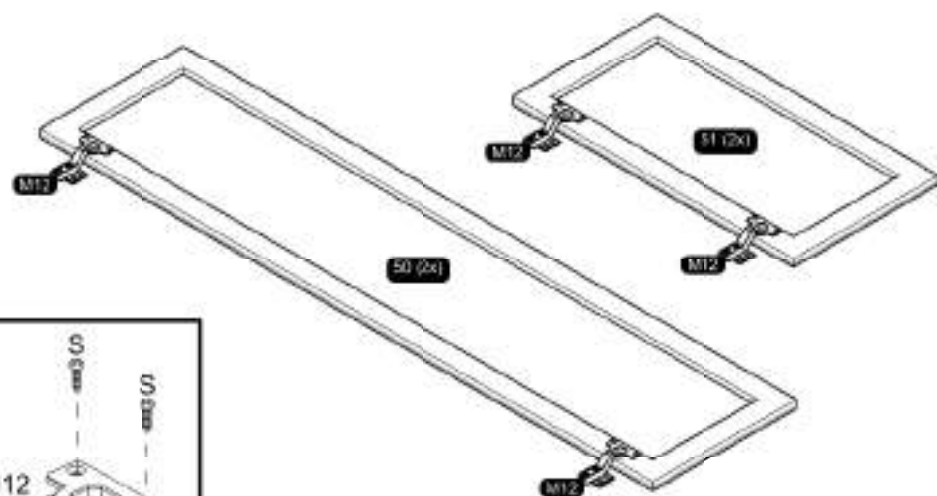

13

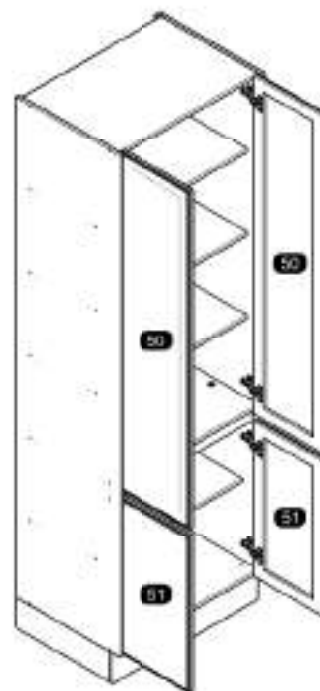

Horizontal Adjustment  
Regulagem Horizontal  
Ajuste Horizontal



Depth Adjustment  
Regulagem Profundidade  
Ajuste Profundidade



Vertical Adjustment  
Regulagem Vertical  
Ajuste Vertical

12

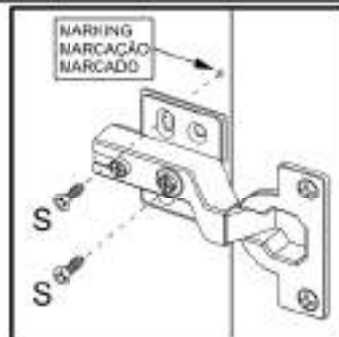
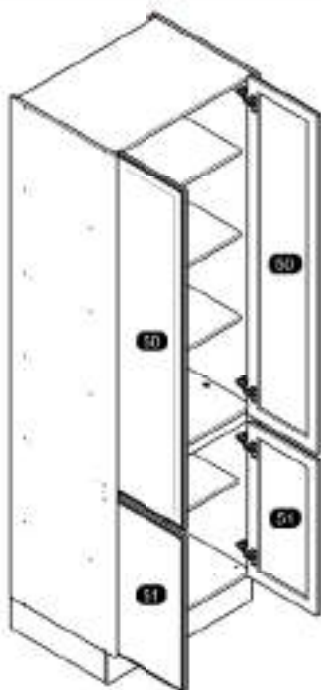

14

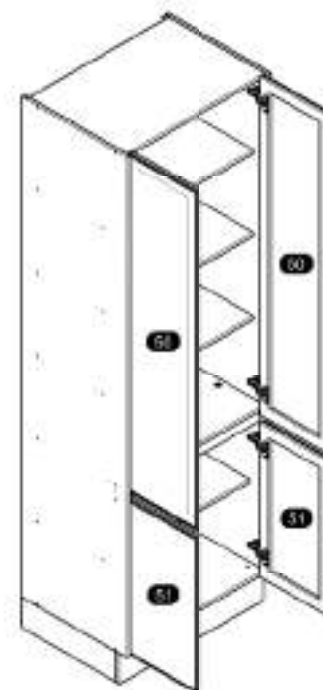

# ASSEMBLY INSTRUCTIONS MANUAL DE MONTAGEM / INSTRUCCIONES DE ARMADO

TOWER 1 FLAP DOOR 1 DRAWER 1 DOOR  
TORRE DE FORNOS 2P 1PB  
TORRE 1 PUERTA HORIZONTAL 1 CAJÓN 1 PUERTA

Reference 260028 | Revise 00  
Referência 260028 | Revisão 00  
Referencia 260028 | Revisión 00

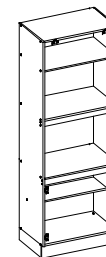

## YOU WILL NEED VOCÊ VAI PRECISAR DE / USTED NECESITARÁ

Tools not supplied  
Ferramentas não fornecidas / Herramientas no incluidas

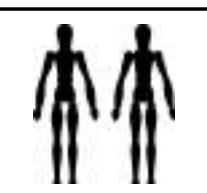

2 People  
2 Pessoas  
2 Personas

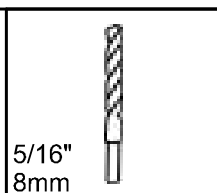

Drill bit  
Broca  
Taladro

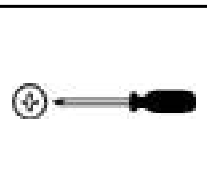

Screwdriver Phillips  
Chave Phillips  
Destornillador cruz



Drill machine  
Furadeira  
Taladro

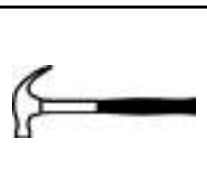

Hammer  
Martelo  
Martillo

**MAXIMUM RECOMMENDED WEIGHT BEING THIS EVENLY DISTRIBUTED.**  
**PESO MÁXIMO RECOMENDADO SENDO ESTE DISTRIBUÍDO UNIFORMEMENTE.**  
**PESO MÁXIMO RECOMENDADO SIENDO ESTE UNIFORMEMENTE DISTRIBUIDO.**

	LB	KG
F	22	10

## PARTS IDENTIFICATION IDENTIFICAÇÃO DAS PEÇAS / IDENTIFICACIÓN DE LAS PIEZAS

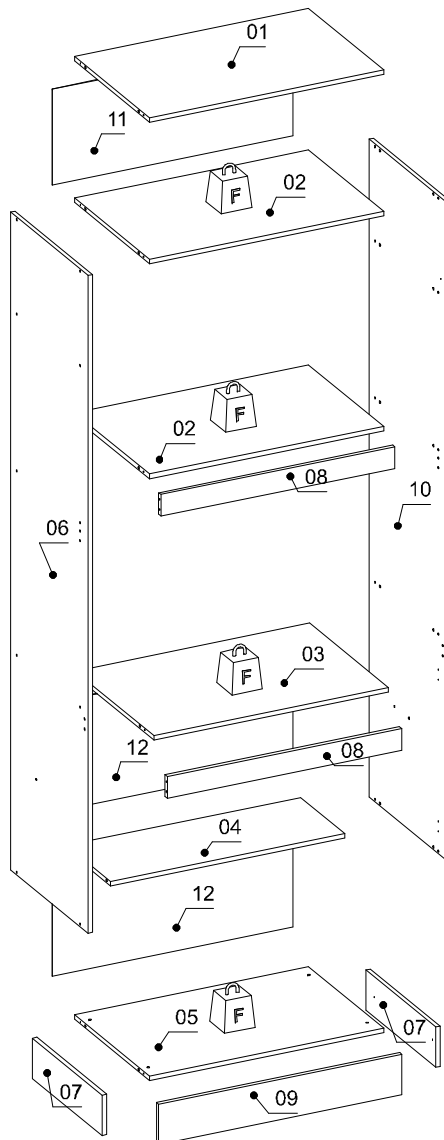

Nº	Measures_Inches	Medidas_cm	Qty./Qtd.
01	19 3/8 x 30 3/8 x 5/8	49.3 x 77.0 x 1.5	1
02	30 3/8 x 19 3/8 x 5/8	77.0 x 49.3 x 1.5	2
03	30 3/8 x 20 3/8 x 5/8	77.0 x 51.8 x 1.5	1
04	30 3/8 x 11 3/8 x 5/8	77.0 x 29.0 x 1.5	1
05	19 3/8 x 30 3/8 x 5/8	49.3 x 77.0 x 1.5	1
06	83 1/2 x 20 1/8 x 5/8	212.0 x 51.0 x 1.5	1
07	18 1/8 x 5 1/8 x 5/8	45.9 x 13.0 x 1.5	2
08	30 3/8 x 2 3/4 x 5/8	77.0 x 7.0 x 1.5	2
09	31 1/2 x 5 1/8 x 5/8	80.0 x 13.0 x 1.5	1
10	83 1/2 x 20 1/8 x 5/8	212.0 x 51.0 x 1.5	1
11	31 1/8 x 12 1/8 x 1/8	79.0 x 30.9 x 0.3	1
12	31 1/8 x 13 7/8 x 1/8	79.0 x 35.2 x 0.3	2

## IDENTIFICATION OF ACCESSORIES IDENTIFICAÇÃO DOS ACESSÓRIOS/ IDENTIFICACIÓN DE ACCESORIOS



The separation of the accessories before you start the assembly will facilitate the same. In case of doubt on the size of the screws and bolts, use the ruler at bottom of page.  
A separação dos acessórios antes de iniciar a montagem facilitará a mesma. Em caso de dúvida no tamanho dos parafusos e cavilhas, utilize a régua ao final da página.  
La separación de los accesorios antes de comenzar el armado facilitará el mismo. En caso de duda sobre el tamaño de los tornillos y taquetes, utilice la regla al pie de página.

A		Flanged head screw Parafuso flangeado / Tornillo de cabeza flangeada	5,0x90 mm	4
B3		Bushing Buchsa expansiva / Tapón	8x50 mm	4
C1		Metal claw Garras de metal / Garras metal	-	4
E		Wooden dowel Cavilha / Taquete	8x30 mm	24
L1		Flat head screw Parafuso chato / Tornillo de cabeza plana	7,0x40 mm	4
L3		Plastic Foot Soporo / Pie Plástico	-	4
M12		Metal hinge super tight Dobradiza super alta / Bisagra alta	35 mm	04
N		Nail Prego / Clavo	10x10	56
N4		Loop Presilha / Presilla	-	6
N5		Support "L" Suporte "L" / Soporte "L"	-	4
O		Flat head screw Parafuso chato / Tornillo de cabeza plana	4,5x45 mm	30
S		Pan head screw Parafuso panela / Tornillo de pan	3,5x14 mm	50
S7A		Gas piston Pistão a gás / Pistón de gas	-	1
S7B		Side support piston Suporte pistão lateral / Soporte pistón lateral	-	1
S7C		Door support piston Suporte pistão porta / Soporte pistón puerta	-	1
S7D		Pan head screw Parafuso panela / Tornillo de pan	3,5x12 mm	5
Z13		Metal hinge straight Dobradiza retil / Bisagra recta	35 mm	2



## PRE-ASSEMBLE PRÉ-MONTAGEM / PRE ARMADO

01

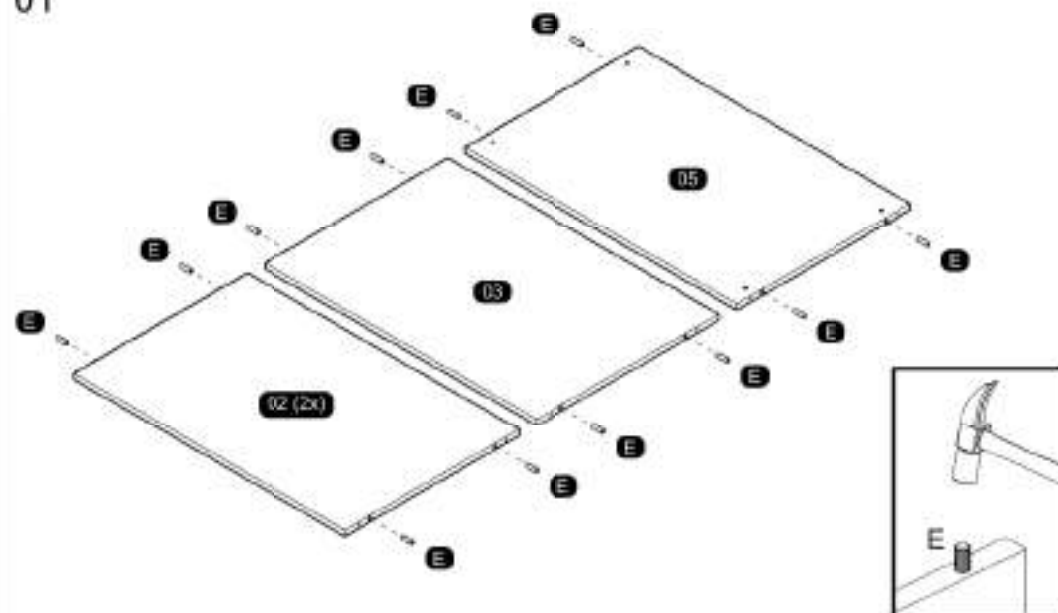

02

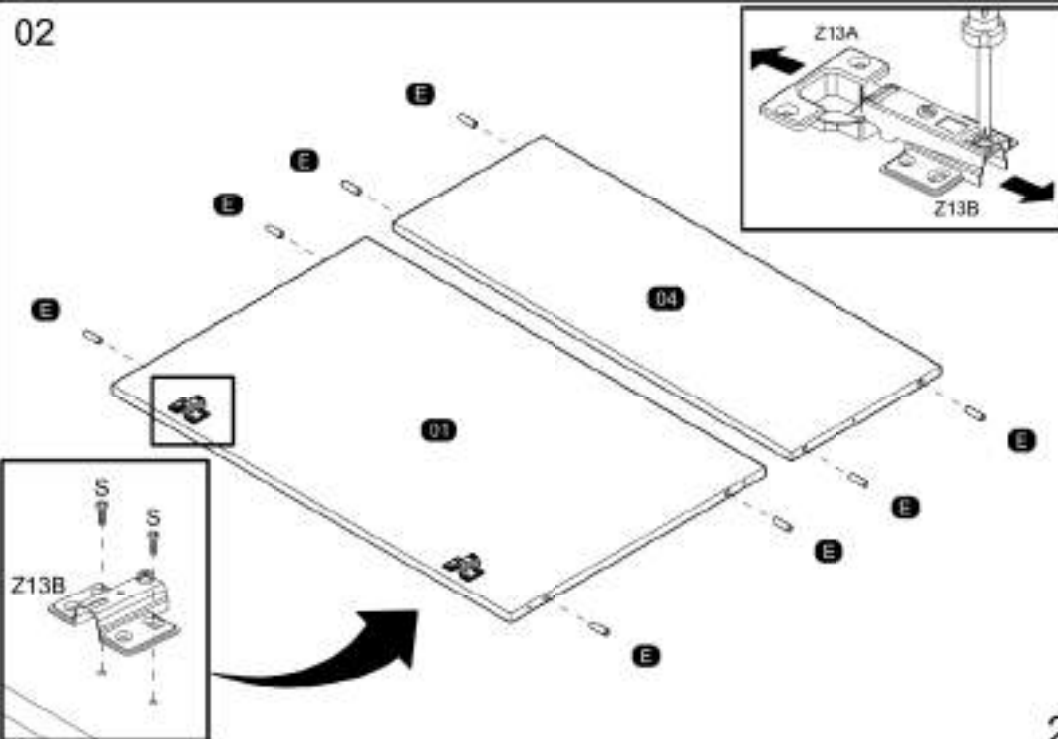

03

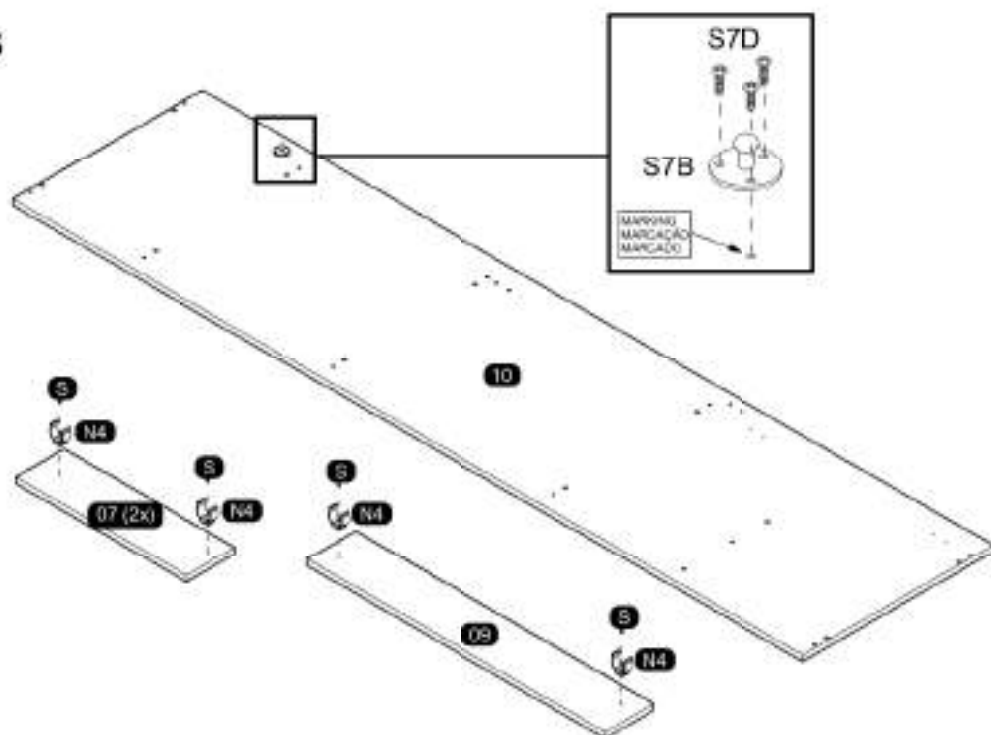

05

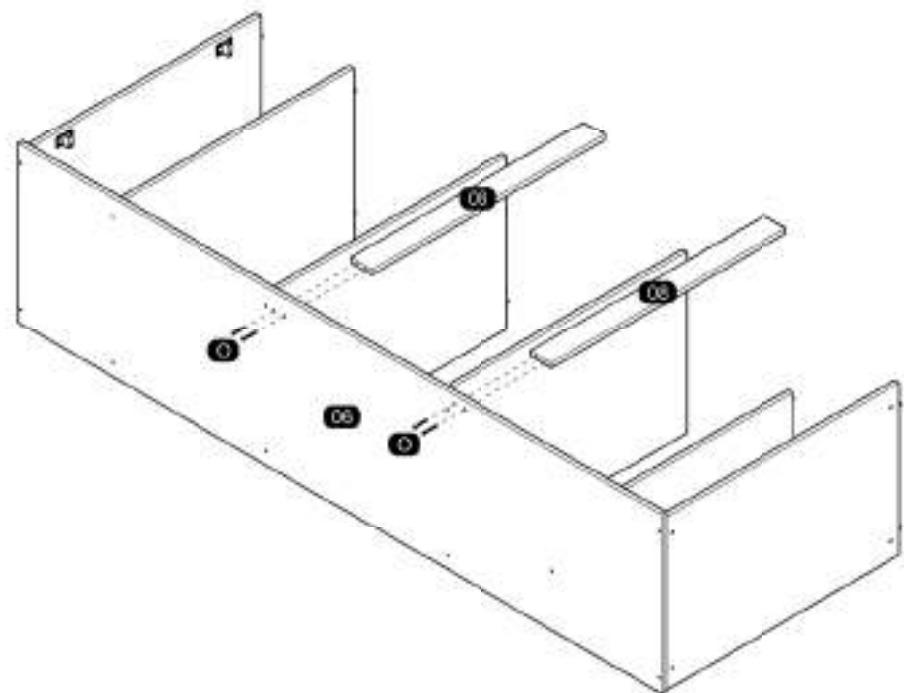

**ASSEMBLY  
MONTAGEM / ARMADO**

04

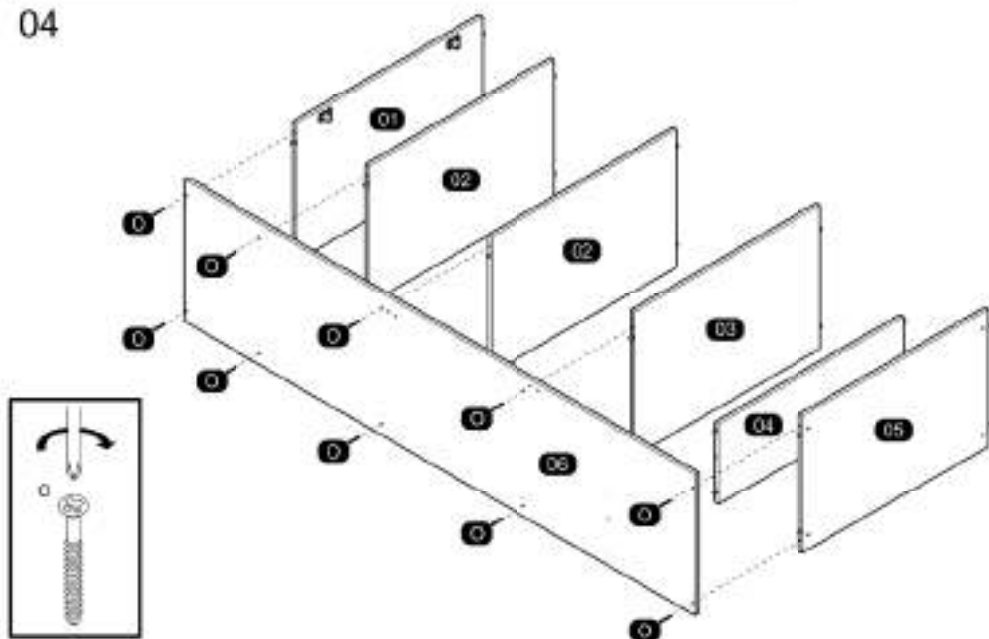

06

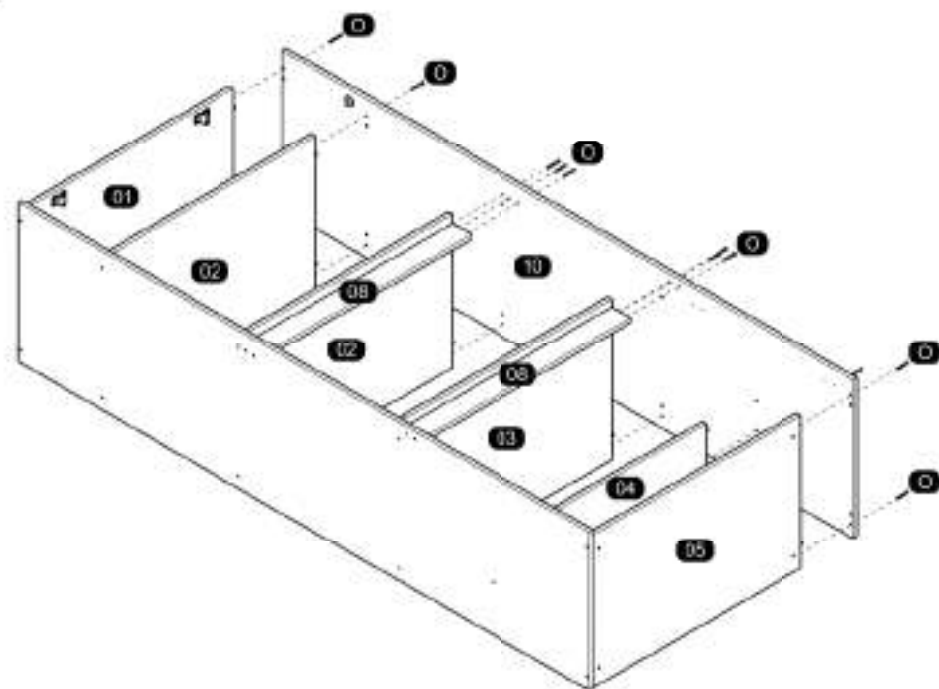

11

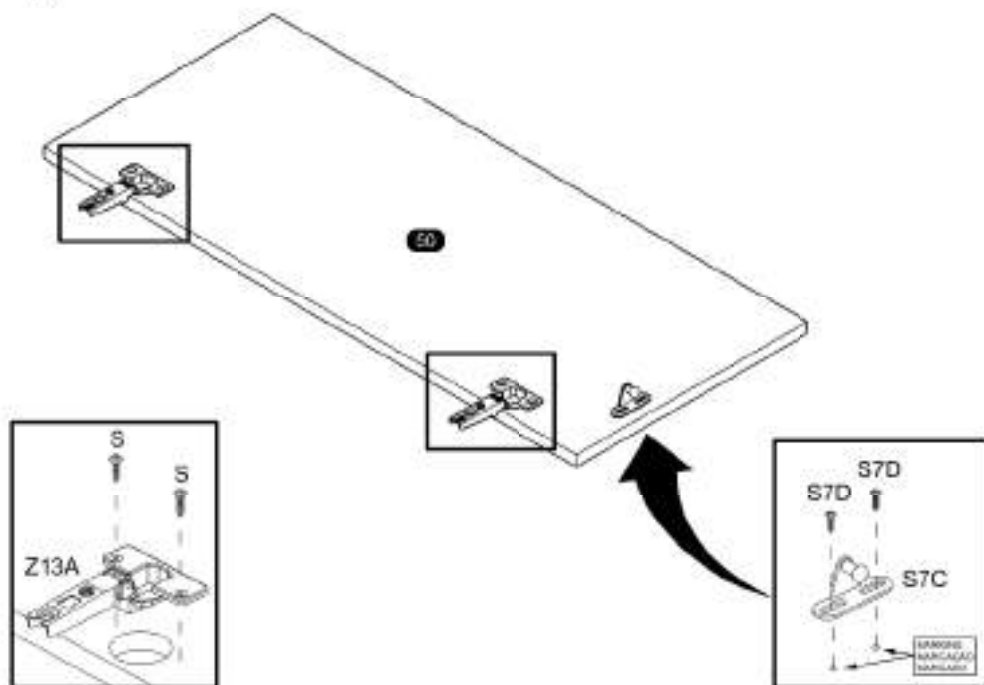

13

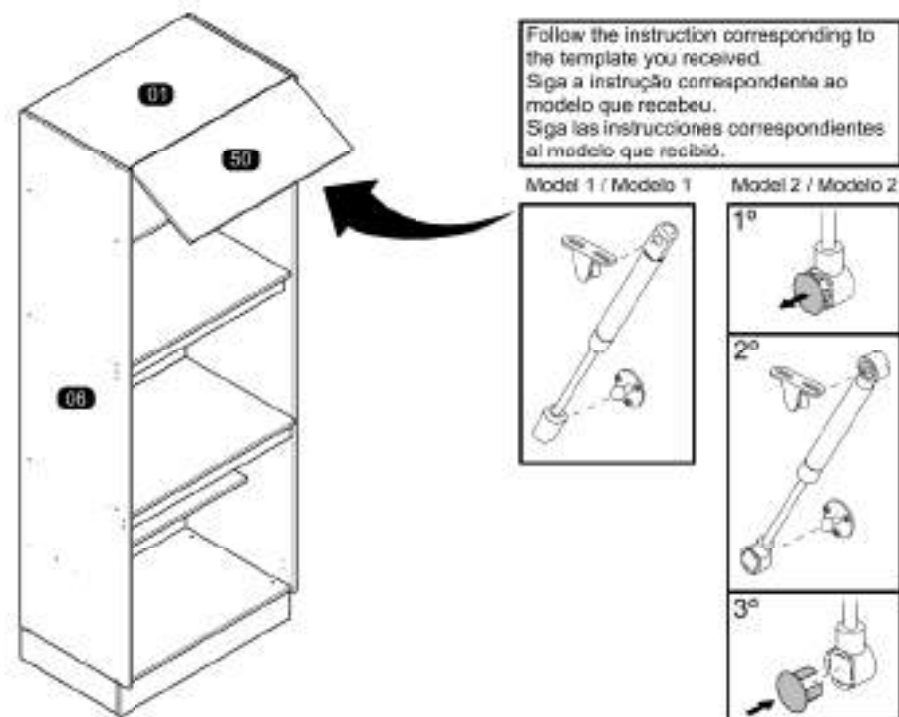

12

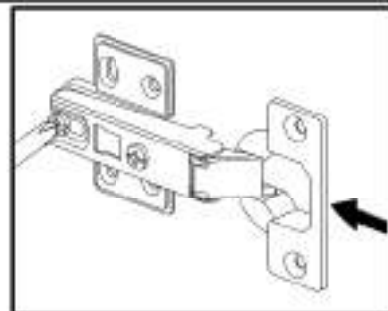
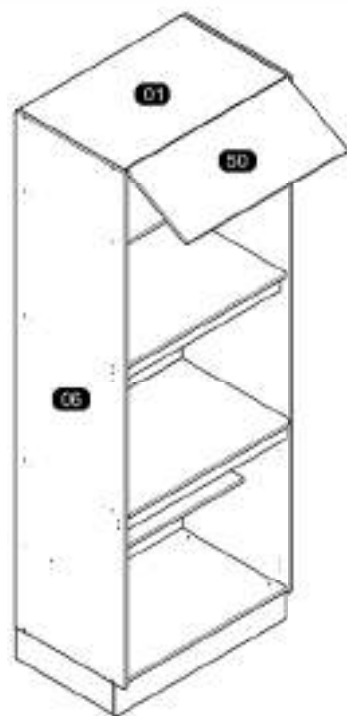

14

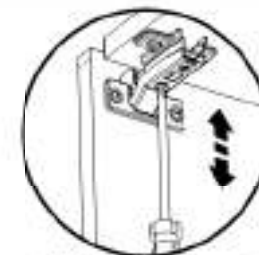
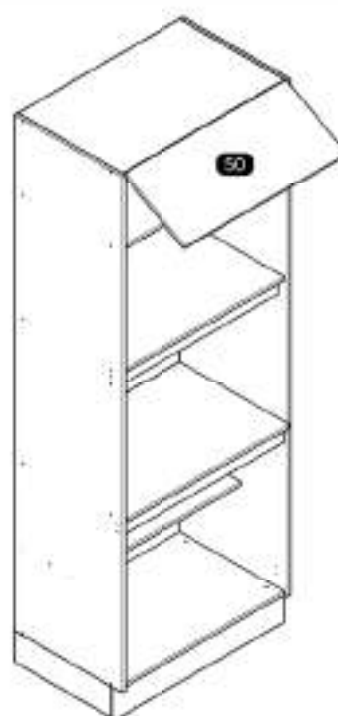

Vertical Adjustment  
Regulagem Vertical  
Ajuste Vertical

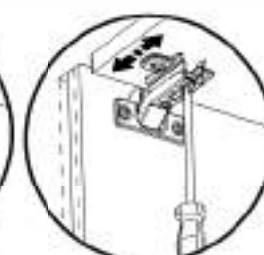

Depth Adjustment  
Regulagem Profundidade  
Ajuste Profundidad

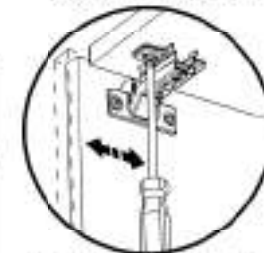
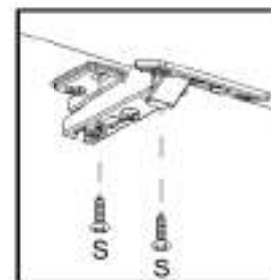

Horizontal Adjustment  
Regulagem Horizontal  
Ajuste Horizontal

15

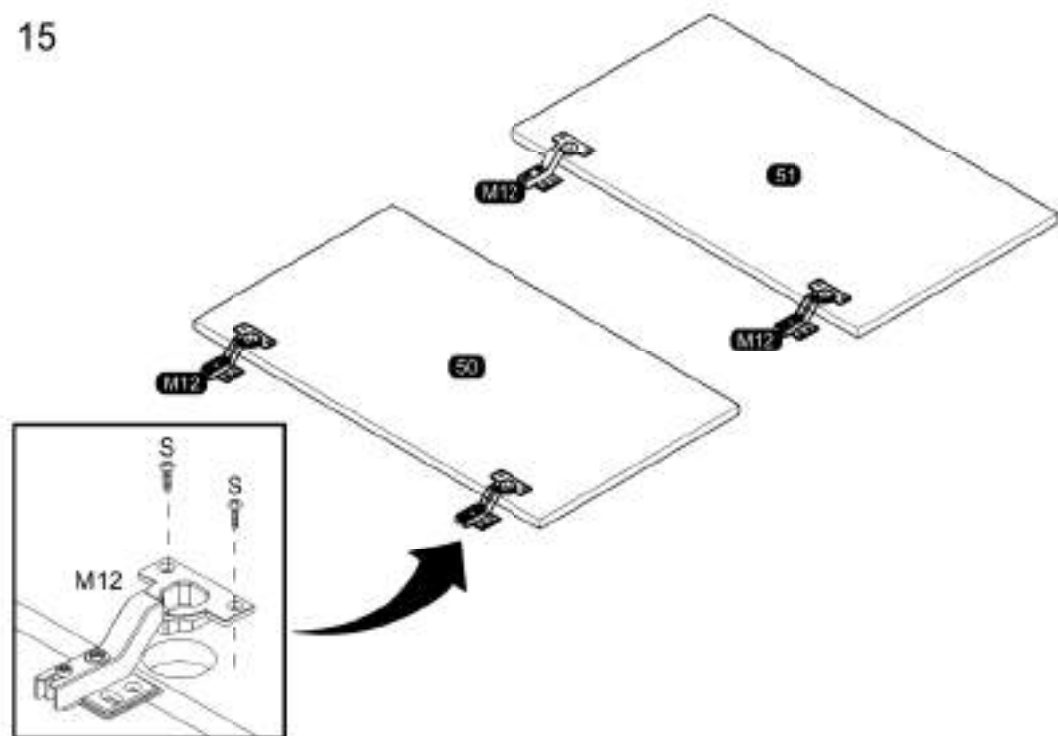

17

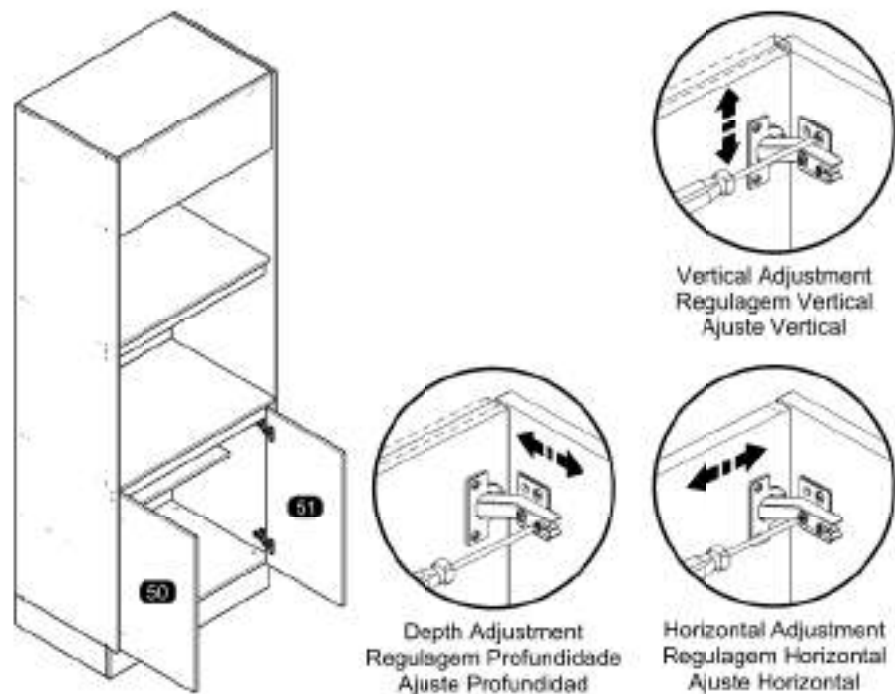

16

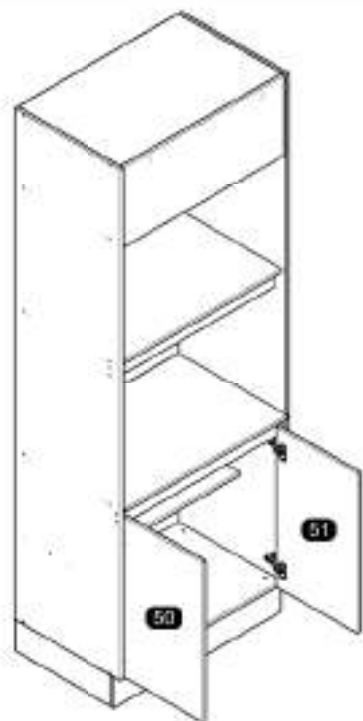

18

