

Roupeiro / Ropero / Wardrobe

4P2G SAO LUIS NEW

BC-3714



Instruções para a montagem do produto:

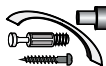

Separe as peças e acessórios de maneira organizada.

Separate the parts and accessories in an organized way.

Separe las piezas y accesorios de forma organizada

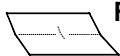

Forrar o chão com o papelão das embalagens.

Cover the floor with the cardboard from the pack.

Cubre el suelo con el cartón de los bultos.



É necessário duas pessoas para montar o produto.

It's necessary two people to assembly the product.

Se requiere dos personas para montar el producto.

Ferramentas necessárias (não fornecidas)

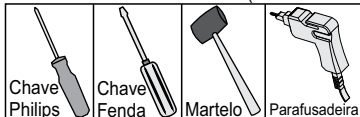

Lote: 000000

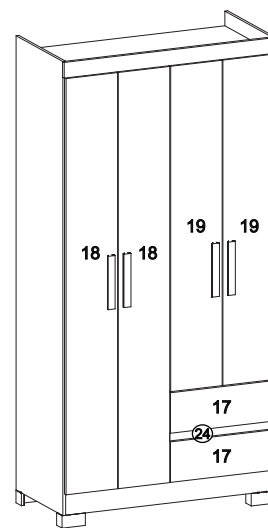

PO
R

- 01-LATERAL ESQUERDA
- 02-LATERAL DIREITA
- 03-DIVISAO ESQUERDA
- 05-TAMPO SUPERIOR
- 06-TAMPO MALEIRO
- 07-TAMPO CENTRAL
- 08-PILASTRAS SUPERIOR
- 09-PILASTRA INFERIOR
- 11-RODAPÉ FRONTAL
- 12-RODAPÉ TRASEIRO
- 13-TRAVESSA DE RODAPÉ
- 14-FRONTAL
- 15-LATERAL DE GAVETA (4x)
- 16-TRASEIRO DE GAVETA (2x)
- 17-FRENTE DE GAVETA (2X)
- 18-PORTAS LATERAIS (2X)
- 19-PORTAS CENTRAIS (2X)
- 20-FUNDO DE GAVETA (2X)
- 21-COSTA MALEIRO
- 22-COSTAS (2X)
- 23-TAMPO INFERIOR
- 24- TRAVESSA GAVETA

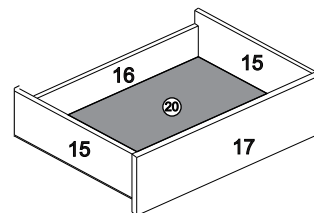

LI
SO

- 01-LADO IZQUIERDO
- 02-LADO DERECHO
- 03-DIVISIÓN IZQUIERDA
- 05-TAPA SUPERIOR
- 06-TAPA DEL COMPARTIMENTO
- 08-PILARES SUPERIORES
- 09-PARTE INFERIOR
- 11-RODAPIÉ DELANTERO
- 12-RODAPIÉ TRASERO
- 13-TRAVESAÑO DEL RODAPIÉ
- 14-PARTE DELANTERA
- 15-LATERAL DE CAJONES (4x)
- 16-TRASERA DE CAJONES (2x)
- 17-FRONTAL DE CAJONES (2x)
- 18-PUERTAS LATERALES (2x)
- 19-PUERTAS CENTRALES (2x)
- 20-FONDO DEL CAJÓN (2x)
- 21-TRASERA DEL COMPARTIMENTO
- 22-TRASERA (2x)
- 23-TAPA INFERIOR
- 24-TRAVESAÑO DEL CAJÓN

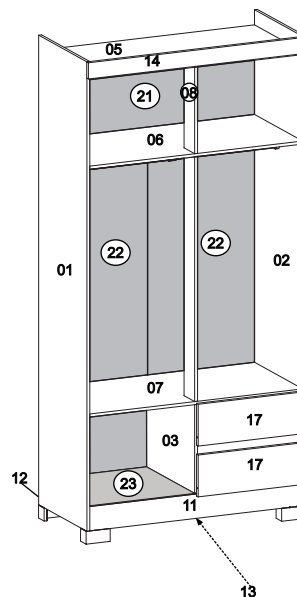

LI
SO

- 01-LEFT SIDE
- 02-RIGHT SIDE
- 03-PARTITIONER
- 05-TOP TOP
- 06-STORAGE COMPARTMENT TOP
- 07-CENTRAL TOP
- 08-UPPER PILLARS
- 09-LOWER PILLAR
- 11-FRONT BASEBOARD
- 12-REAR BASEBOARD
- 13-BASEBOARD CROSSBAR
- 14-FRONT
- 15-DRAWER SIDE (4x)
- 16-DRAWER BACK (2x)
- 17-DRAWER FRONT (2x)
- 18-SIDE DOORS (2x)
- 19-CENTRAL DOORS (2x)
- 20-DRAWER BOTTOM (2x)
- 21-STORAGE COMPARTMENT BACK
- 22-BACK (2x)
- 23-BOTTOM TOP
- 24- DRAWER TRAY

DIMENSÕES PEÇAS PRONTAS

- 01-1830X434X12
- 02-1830X434X12
- 03-349X432X12
- 04-884X433X12
- 05-884X433X12
- 06-884X433X12
- 07-337X95X12
- 08-954X95X12
- 11-884X95X15
- 12-884X95X15
- 13-401X65X12
- 14-910X63X15
- 15-338X95X12
- 16-390X65X12
- 17-444X163X12
- 18-1677X221X15
- 19-1311X221X15
- 20-410X341X3
- 21-898X349X3
- 22-1334X449X3
- 23-436X65X3
- 24-436X431X12

DIMENSIONES DE LAS PEZAS PRONTAS

- 01-1830X434X12
- 02-1830X434X12
- 03-349X432X12
- 04-884X433X12
- 05-884X433X12
- 06-884X433X12
- 07-337X95X12
- 08-954X95X12
- 11-884X95X15
- 12-884X95X15
- 13-401X65X12
- 14-910X63X15
- 15-338X95X12
- 16-390X65X12
- 17-444X163X12
- 18-1677X221X15
- 19-1311X221X15
- 20-410X341X3
- 21-898X349X3
- 22-1334X449X3
- 23-436X65X3
- 24-436X431X12

DIMENSIONS READY MODE PARTS

- 01-1830X434X12
- 02-1830X434X12
- 03-349X432X12
- 04-884X433X12
- 05-884X433X12
- 06-884X433X12
- 07-337X95X12
- 08-954X95X12
- 11-884X95X15
- 12-884X95X15
- 13-401X65X12
- 14-910X63X15
- 15-338X95X12
- 16-390X65X12
- 17-444X163X12
- 18-1677X221X15
- 19-1311X221X15
- 20-410X341X3
- 21-898X349X3
- 22-1334X449X3
- 23-436X65X3
- 24-436X431X12

Ferragens/Herraje/Hardware:

Cód	Itens	Quan
330	A Cavilhas 6 x 30 Clavija Bowel	15
0289	B Parafuso 3,5 x 40 c/c Tornillo Screw	42
0538	C Porca cilíndrica Tuerca cilíndrica Cylindrical nut	16
151	D Dobradiça metal 26 mm Bisagra Hinge	12
0744	E Taxa 13 x 15 Clavo 13 x 15 Nail 13 x 15	08
0296	F Taxa 10 x 7 Clavo 10 x 7 Nail 10 x 7	90
0283	G Parafuso 3,5 x 12 c/c Tornillo Screw	108
0438	H Cantoneira Esquinera Cantoneira	13
0477	I Cola Pegamento Glue	01
0285	J Parafuso 3,5 x 25 c/f Tornillo Screw	10
----	K Puxador Madeira Tirador Handle	04
0645	L Pino Suporte Prateleira Soporte Suport	02
0279	M Fixador de costa Fixador de espalda Fix back	10
-----	N Cabideiro 878mm Perchero Holding	01
-----	O Perfil 954 mm Perfil Profile	01
3049	P Corrediça telescópica 30cm Rieles Slides	02
----	Q KIT PÉ U Foot Kit Juego de Pies	04
5159	R Cavilhas 6 x 50 Clavija Bowel	02
1413	S Suporte cabide sem furo CINZA	02
1415	T Suporte cabideiro Soporte percha Hanger holding	01



Montagem da gaveta Armado de los cajones Drawer Assembly

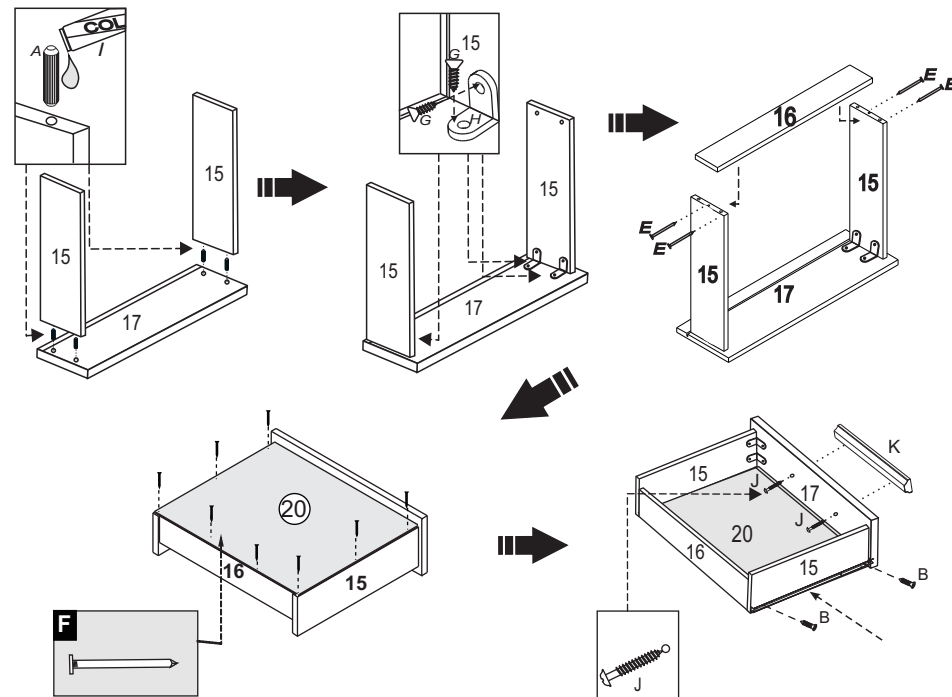

1º Passo 1º Paso 1º Step

Atenção! ao parafusar a corrediça,
cuidar o lado certo.

Atención! al atornillar la corredera,
cuidar para que esté en el lado correcto

Attention! When screwing the slide,
take care to do the right side

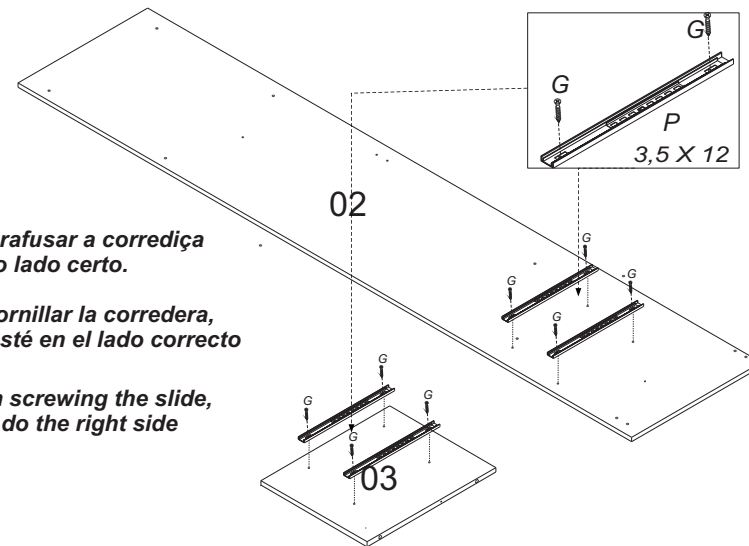

2º Passo
2º Paso
2º Step

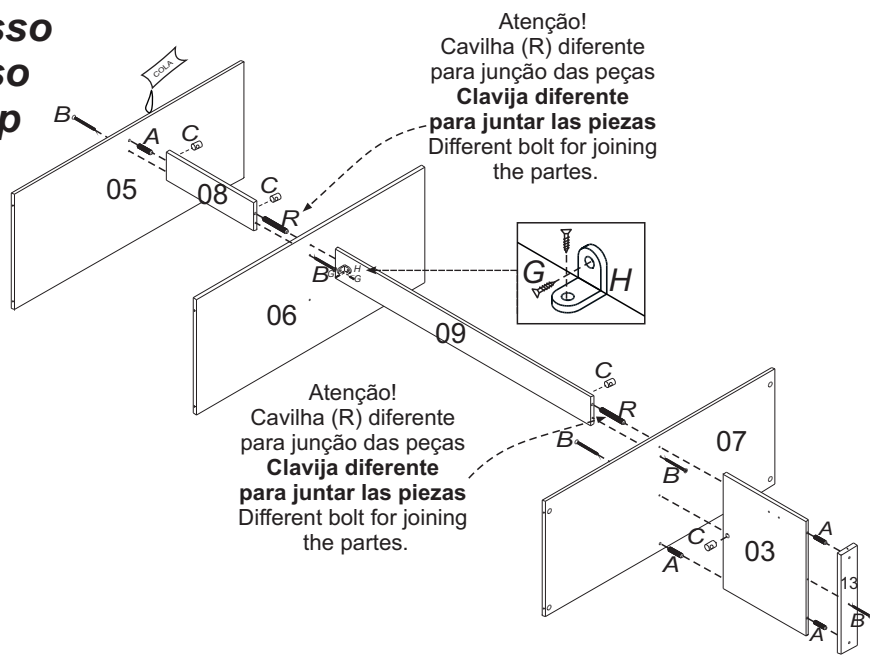

3º Passo
3º Paso
3º Step

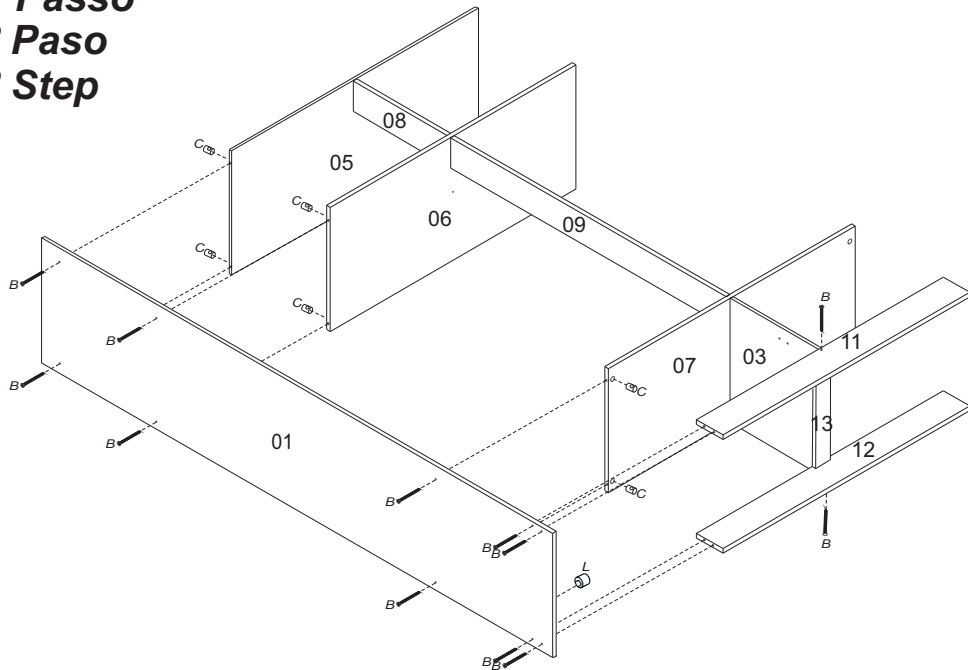

4º Passo
4º Paso
4º Step

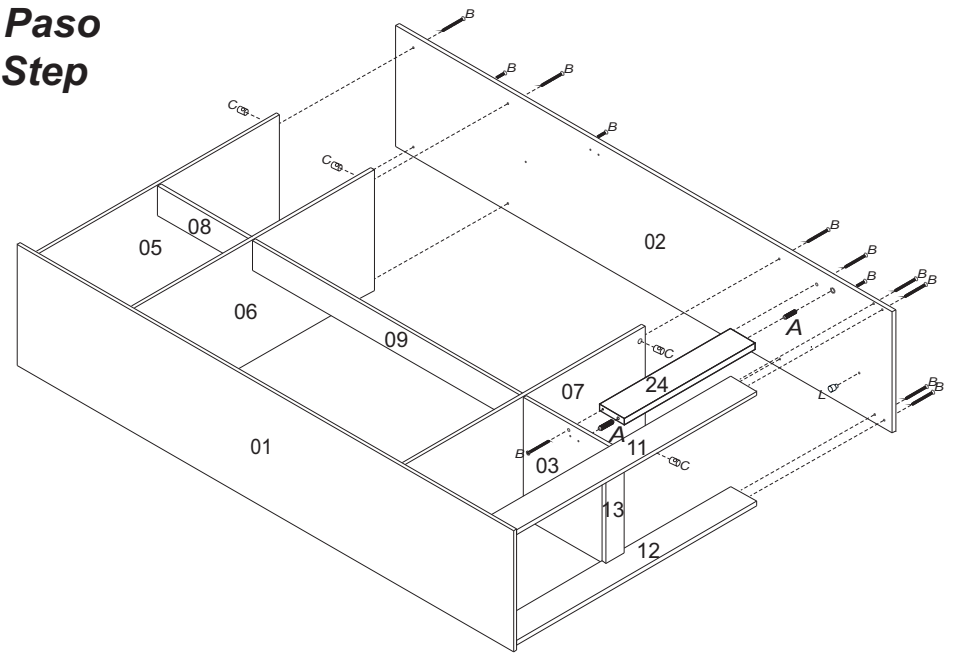

5º Passo
5º Paso
5º Step

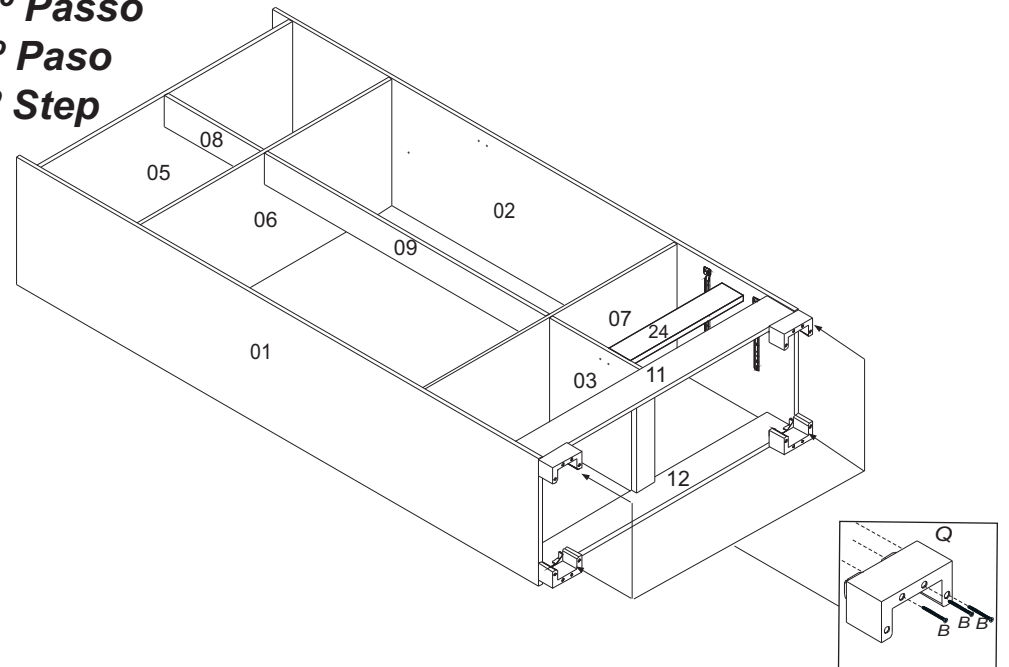

6º Passo
6º Paso
6º Step

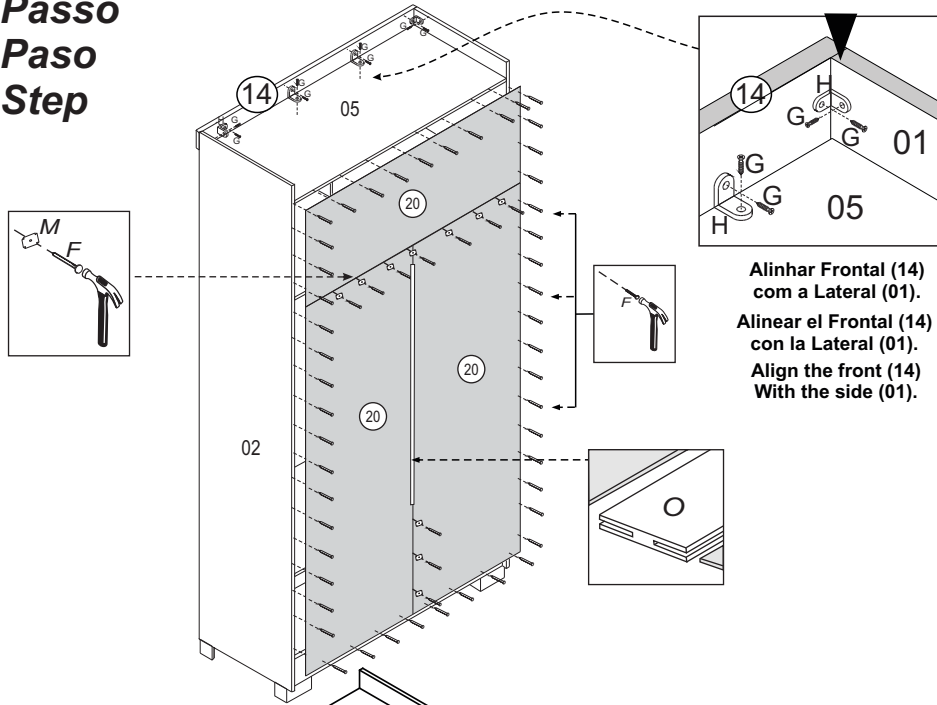

Alinhar Frontal (14) com a Lateral (01).
 Alinear el Frontal (14) con la Lateral (01).
 Align the front (14) With the side (01).

7º Passo
7º Paso
7º Step

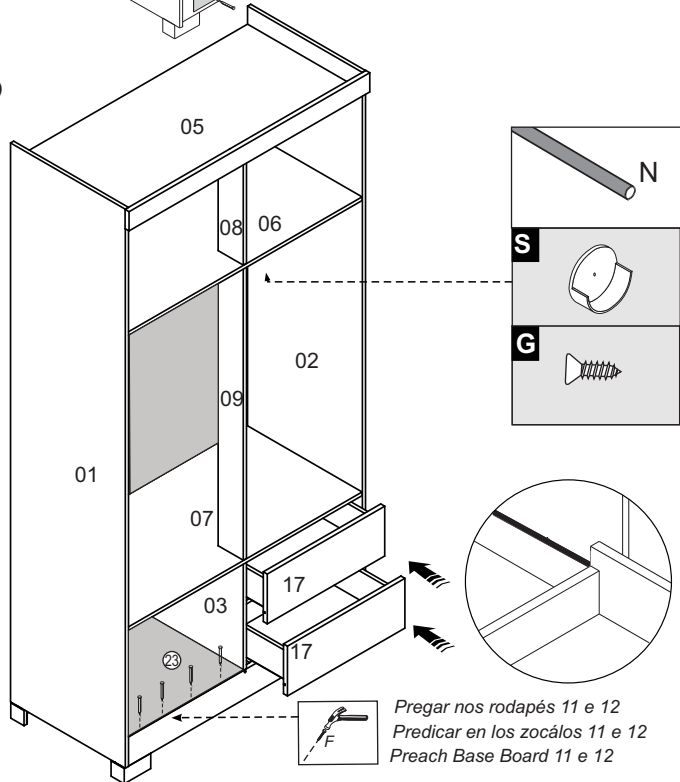

Pregar nos rodapés 11 e 12
 Predicar en los zocálos 11 e 12
 Preach Base Board 11 e 12

8º Passo
8º Paso
8º Step

Montagem das dobradiças nas portas (18,19) colocando calço e dobradiça.
 Montaje de las bisagras en las puertas (18,19) Poner la base y bisagra.
 The assembly of the Hinge in the door (18,19) putting the base of Hinge and hinge.

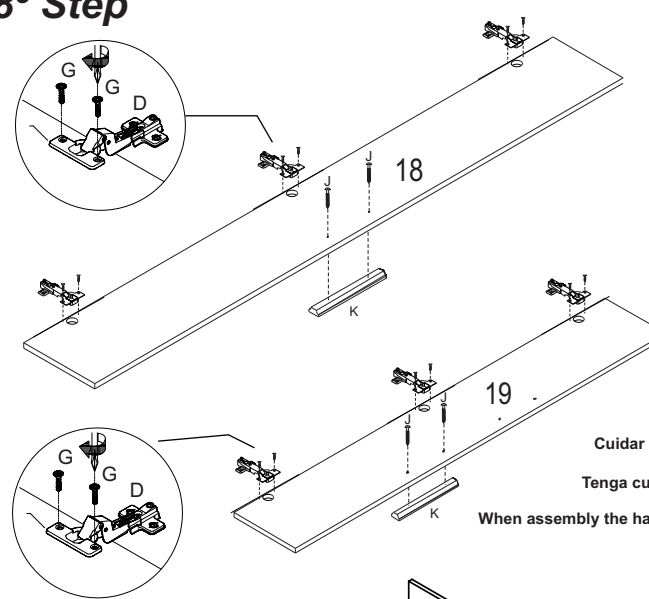

Junção do Calço com a Dobradiça .

Unificación de la base con la bisagra.

Shim union with hinge

Cuidar lado da colocação do Puxador nas portas (19)

Tenga cuidado con la colocación del tirador la Puertas (19)

When assembly the handle holding caution the side to assembly door (19)

9º Passo
9º Paso
9º Step

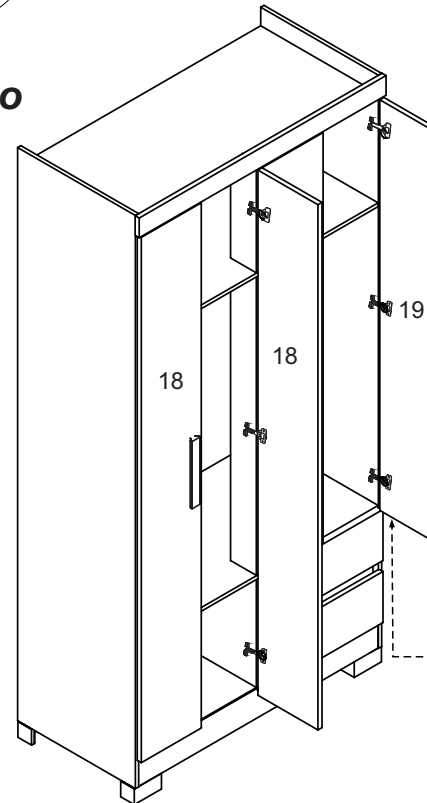

EM TODAS AS PORTAS DA MESMA MANEIRA
 EN TODAS LAS PUERTAS DE LA MISMA MANERA
 ON ALL DOORS THE SAME WAY

REGULAGEM / REGLAJE / ADJUSTMENT

