

**Sr Montador:**

- Confira todas as peças das embalagens com a lista de peças contida neste manual;
- Separe os acessórios, confira as medidas dos parafusos com a escala;
- Siga todas as orientações deste manual de montagem para ter o direito à garantia do produto;
- Indicamos que a montagem seja feita por um profissional mediante a leitura e orientação desse manual de montagem

**Mr. Assembler:**

- Check all parts of the packages with the parts list contained in this manual;
- Separate the accessories, check the measurements of the screws with the scale above;
- Follow all the instructions in this assembly manual to be entitled to product warranty;
- We indicate the assembly by a professional according to the reading and orientation contained in the assembly scheme

**Sr Montador:**

- Verifique que todas las piezas de la lista están incluidas en el embalage;
- Separe los accesorios, confirme las medidas de los tornillos de acuerdo con la escala;
- Siga todas las instrucciones de este manual de armado para tener derecho a la garantía del producto;
- Indicamos el armado por un profesional según la lectura y orientación contenida en el esquema de armado



Código da Peça  
Piece Code  
Código de la Pieza

00000 0 00 -00

Padrões de Cor  
Color default  
Padrón de Color



Tabela de Cor

FREIJO UV/OFF ACETINADO	143
FRE UV/OFF ACE/RIP FRI	184

**Guarde a etiqueta colada na embalagem do produto lá estão informações importantes do seu produto, caso necessite de assistência técnica você precisa informar o número do lote contido na etiqueta.**

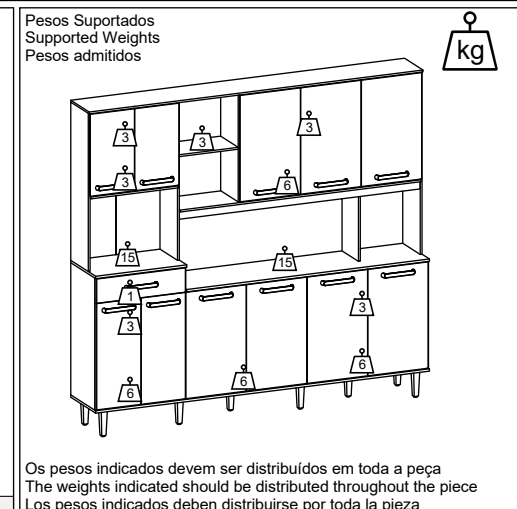
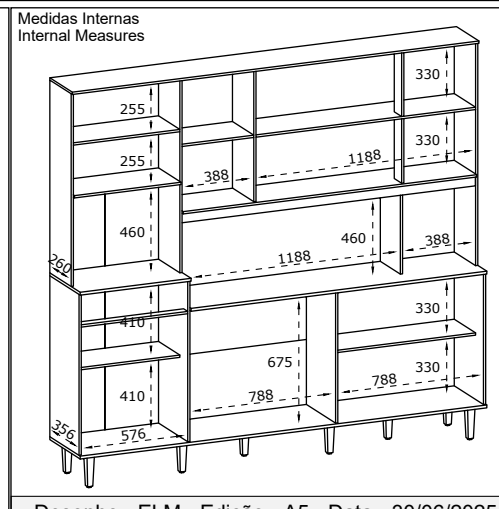
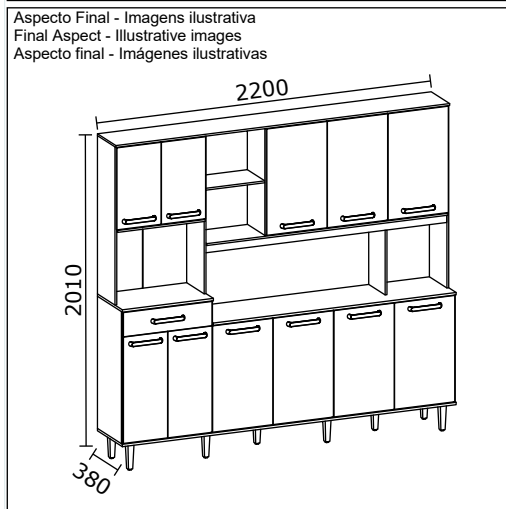
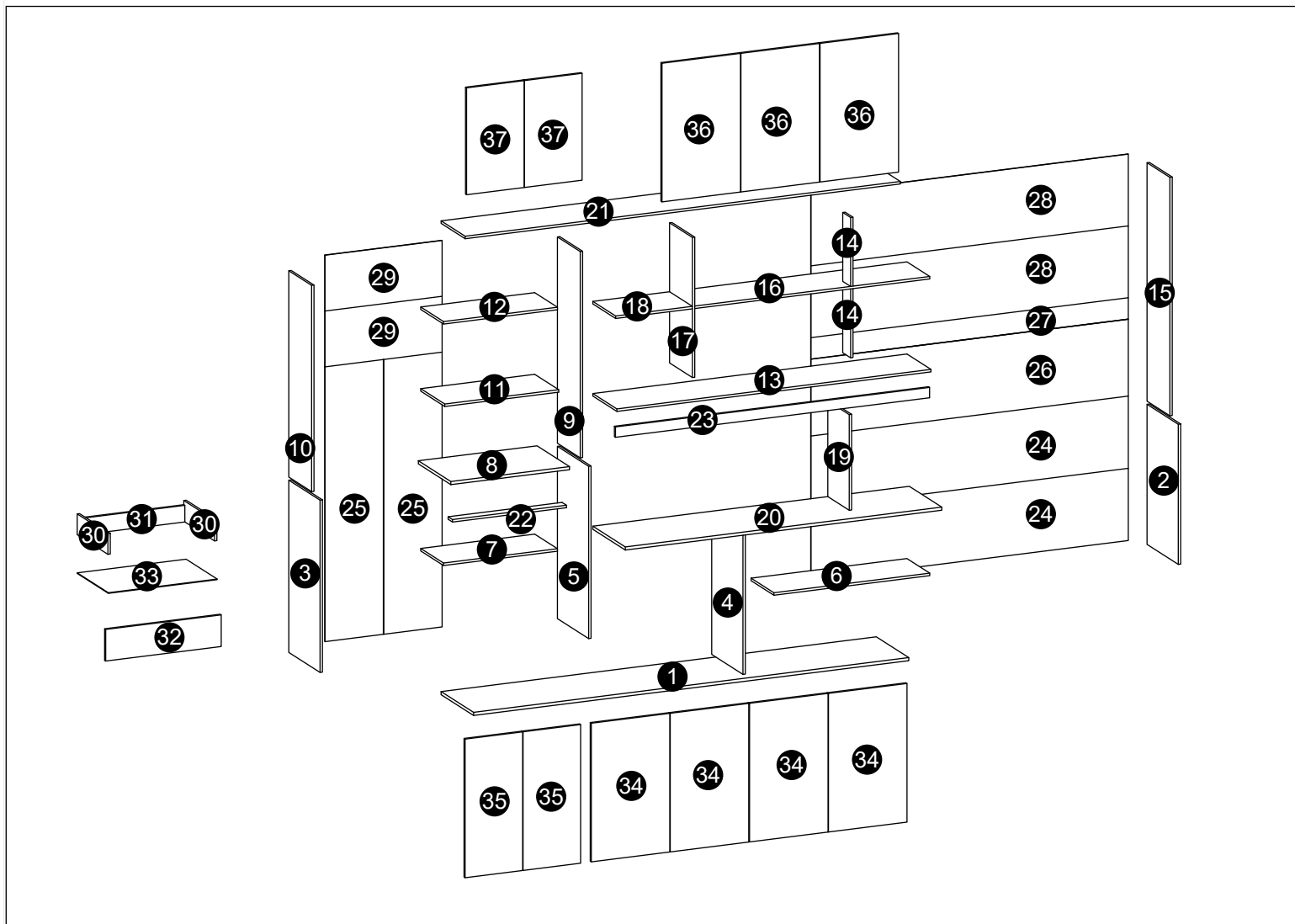

## Utilizar a régua para medir os componentes

Utilice la medida abajo para medir los componentes  
Use the ruler in order to measure the following components



## Passos da Montagem Pasos del montaje / Mounting Steps

Todos os parafusos da tabela são do tipo Philips  
All screws in the table are Philips type.  
Todos los tornillos de la mesa son tipo Philips.

<b>Parafuso Chato</b> 4,0x40mm  A 60X	<b>Parafuso Chato</b> 3,5x12mm  B 145X	<b>Cavilha Madeira</b> 6x30mm  C 30X	<b>Prego 10x10mm</b>  D 148X	<b>Fixador Parada de Porta Branco</b>  E 4X	<b>Tapa Furo Adesivo</b>  F 18X	<b>Calço Médio</b>  G 22X
<b>Dobradiça Metálica Curva 26Ø</b>  H 22X	<b>Parafuso Chato</b> 5,0x50mm  I 8X	<b>Parafuso Chato</b> 4,0x25mm  J 24X	<b>Puxador Geórgia</b> 192mm  K 12X	<b>Logo 35x15mm</b>  L 1X	<b>Cantoneira Metálica</b> 16x16mm  M 27X	<b>Sachê Cola PVA</b> 10g  N 1X
<b>Pé Regulável</b> 160mm Piramide  O 8X	<b>Corrediza Telescópica</b> 350mm Extra Light  P 1X	<b>Parafuso M4 com Porca</b>  Q 12X	<b>Perfil I. 1590mm</b>  R 1X	<b>Perfil I. 1307mm</b>  S 1X	<b>Perfil I. 789mm</b>  T 1X	<b>Junção para Fundo Traseiro</b>  U 52X

CÓD	SEQ	DESCRIÇÃO	DESCRIPTION	DESCRIPCIÓN	QTD	COMP	LARG	ESP	MAT-PRIMA	VOL
15034001	1	BASE	BASE	BASE	1	2200	370	15	MDP	1
15034002	2	LAT INF DIR	LAT BTM RT	LAT INF DER	1	675	356	12	MDP	2
15034003	3	LAT INF ESQ	LAT BTM LFT	LAT INF IZQ	1	830	356	12	MDP	2
15034004	4	DIV INF DIR	DIV BTM RT	DIV INF DER	1	675	356	12	MDP	2
15034005	5	DIV INF ESQ	DIV BTM LFT	DIV INF IZQ	1	830	356	12	MDP	2
15034006	6	PRAT INF DIR	SHLF BTM RT	EST INF DER	1	788	260	12	MDP	2
15034007	7	PRAT INF ESQ	SHLF BTM LFT	EST INF IZQ	1	576	260	12	MDP	2
15034010	8	TPO MENOR	TOP SM	TAPA PQR	1	600	370	15	MDP	2
15034014	9	DIV SUP ESQ	DIV TOP LFT	DIV SUP IZQ	1	994	260	12	MDP	1
15034012	10	LAT SUP ESQ	LAT TOP LFT	LAT SUP IZQ	1	994	260	12	MDP	1
15034018	11	BASE SUP ESQ	BASE TOP LFT	BASE SUP IZQ	1	576	274	12	MDP	1
15034022	12	PRAT SUP ESQ	SHLF TOP LFT	EST SUP IZQ	1	576	260	12	MDP	2
15034017	13	BASE SUP	BASE TOP	BASE SUP	1	1588	274	12	MDP	1
15034019	14	BTT SUP	BTT TOP	TOPE SUP	2	331	90	12	MDP	2
15034011	15	LAT SUP DIR	LAT TOP RT	LAT SUP DER	1	1149	260	12	MDP	1
15034020	16	PRAT SUP CENT MAIOR	SHLF TOP CTR LG	EST SUP CEN GRD	1	1188	260	12	MDP	1
15034015	17	DIV SUP CENT	DIV TOP CTR	DIV SUP CEN	1	675	260	12	MDP	1
15034021	18	PRAT SUP CENT MENOR	SHLF TOP CTR SM	EST SUP CEN PQR	1	388	260	12	MDP	1
15034013	19	DIV SUP DIR	DIV TOP RT	DIV SUP DER	1	461	244	12	MDP	1
15034009	20	TPO MAIOR	TOP LG	TAPA GRD	1	1600	370	15	MDP	2
15034023	21	CHAPEU	CAP	CHAP	1	2200	274	12	MDP	1
15034008	22	VST INF ESQ	VST BTM LFT	VST INF IZQ	1	576	50	12	MDP	1
15034016	23	VST SUP MAIOR	VST TOP LG	VST SUP GRD	1	1588	50	12	MDP	1
15034027	24	FND DUPLO INF DIR	DBL BCK BTM RT	FDO DBL INF DER	2	1604	348	3	HDF	1
15034028	25	FND DUPLO INF ESQ	DBL BCK BTM LFT	FDO DBL INF IZQ	2	1324	295	3	HDF	2
15034029	26	FND CENT DIR	BCK CTR RT	FDO CEN DER	1	1604	370	3	HDF	1
15034030	27	FND SUP CENT MENOR	BCK TOP CTR SM	FDO SUP CEN PQR	1	1604	103	3	HDF	1
15034031	28	FND DUPLO SUP DIR	DBL BCK TOP RT	FDO DBL SUP DER	2	1604	346	3	HDF	1
15034032	29	FND DUPLO SUP ESQ	DBL BCK TOP LFT	FDO DBL SUP IZQ	2	269	592	3	HDF	2
U0000004	30	LAT GAV	LAT DRW	LAT CAJ	2	350	100	12	MDP	2
15034025	31	CTF GAV	CTF DRW	CTF CAJ	1	527	80	12	MDP	1
15034035	32	FT GAV	FT DRW	FRNT CAJ	1	584	152	12	MDP	3
15034026	33	FND GAV	BCK DRW	FDO CAJ	1	550	354	3	HDF	2
15034037	34	PT INF MAIOR	DR BTM LG	PTA INF GRD	4	668	397	12	MDP	3
15034034	35	PT INF MENOR	DR BTM SM	PTA INF PQR	2	668	291	12	MDP	3
15034038	36	PT SUP MAIOR	DR TOP LG	PTA SUP GRD	3	668	397	12	MDP	3
15034036	37	PT SUP MENOR	DR TOP SM	PTA SUP PQR	2	515	291	12	MDP	3
Portas Frisadas										
15034033	36	PT SUP MAIOR	DR TOP LG	PTA SUP GRD	3	668	397	12	MDF	3

PASSO 1  
PASO/STEP

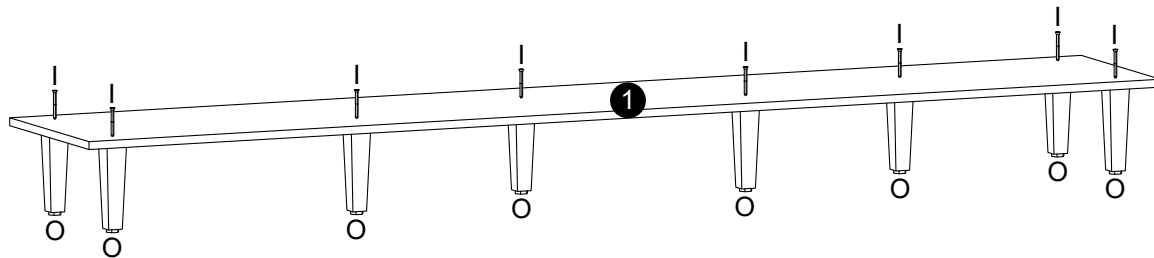

Parafuso Chato  
5,0x50mm



Pé Regulável  
160mm  
Piramide



PASSO 2  
PASO/STEP

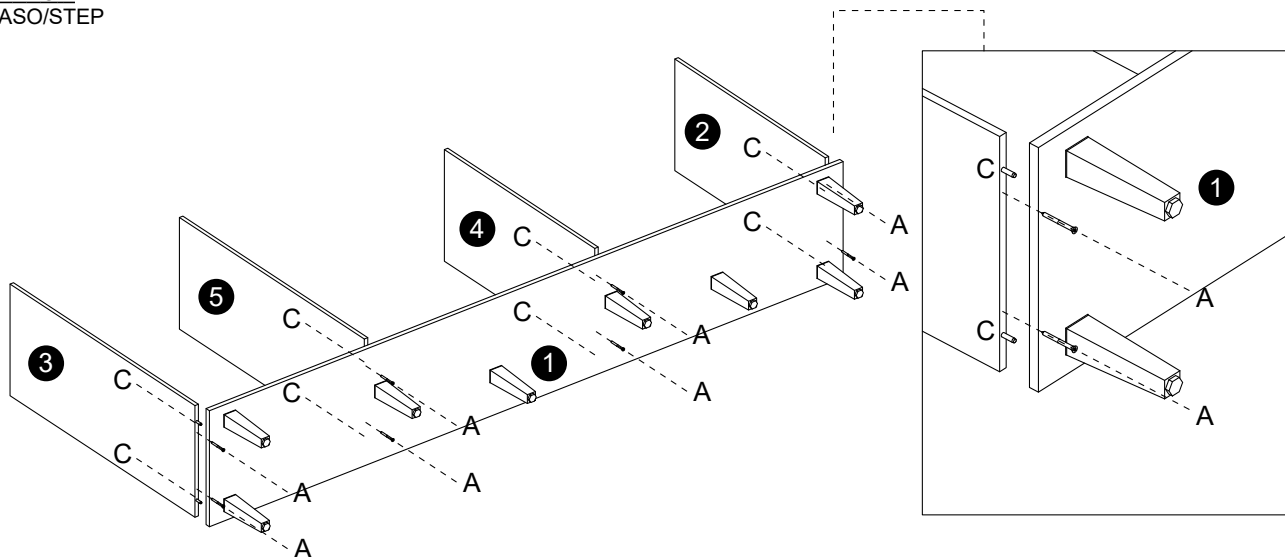

Parafuso Chato  
4,0x40mm

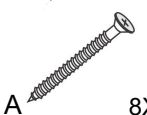

Cavilha Madeira  
6x30mm

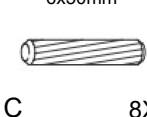

PASSO 3  
PASO/STEP

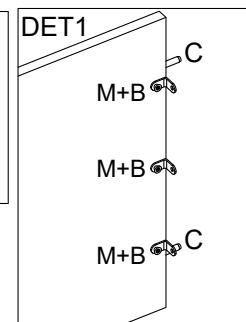
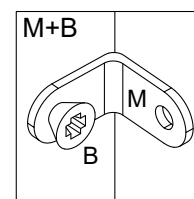
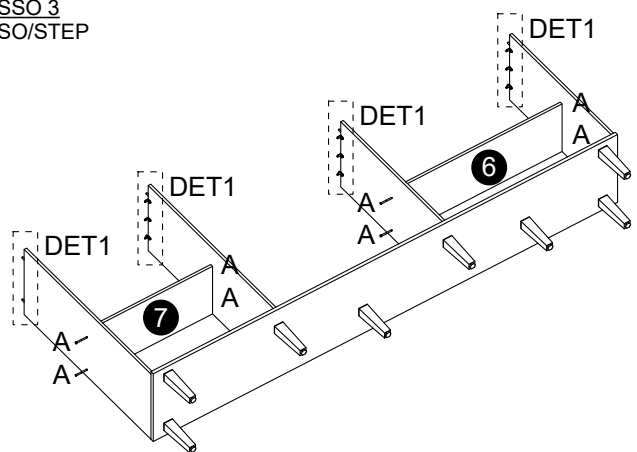

Parafuso Chato  
3,5x12mm

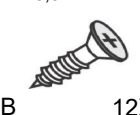

Parafuso Chato  
4,0x40mm



Cantoneira  
Metálica 16x16mm

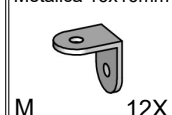

Cavilha Madeira  
6x30mm

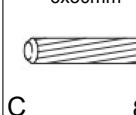

PASSO 4  
PASO/STEP

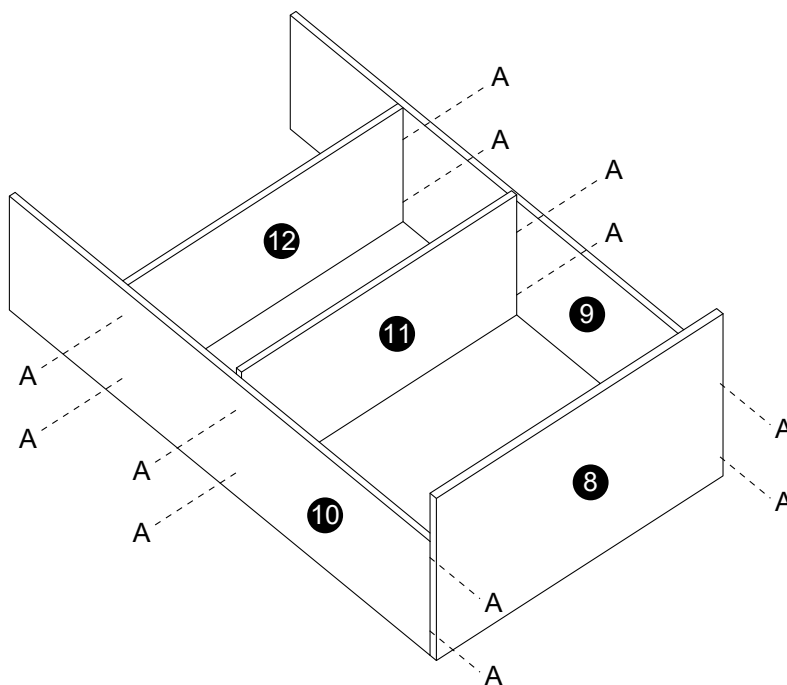

Parafuso Chato  
4,0x40mm



PASSO 5  
PASO/STEP

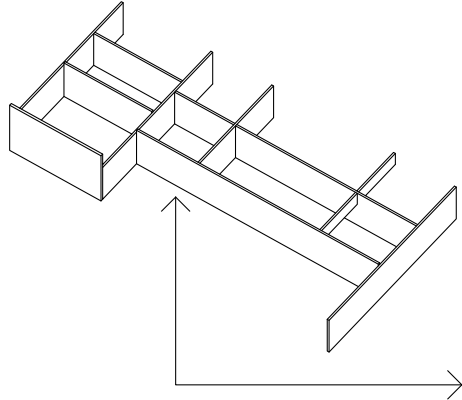

Cavilha Madeira  
6x30mm



C 8X

Parafuso Chato  
4,0x40mm



A 8X

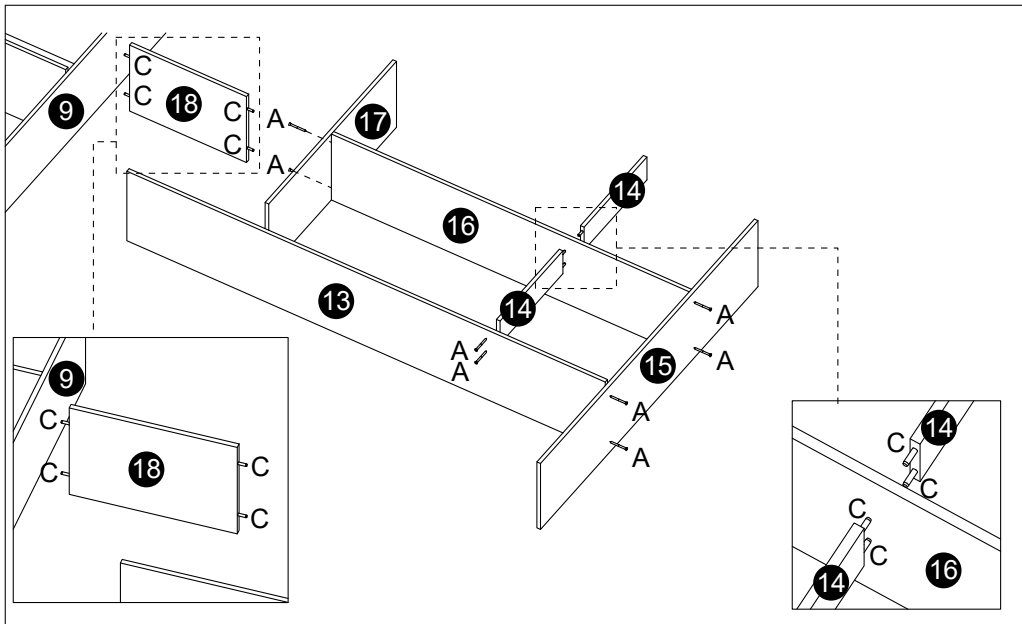

PASSO 6  
PASO/STEP

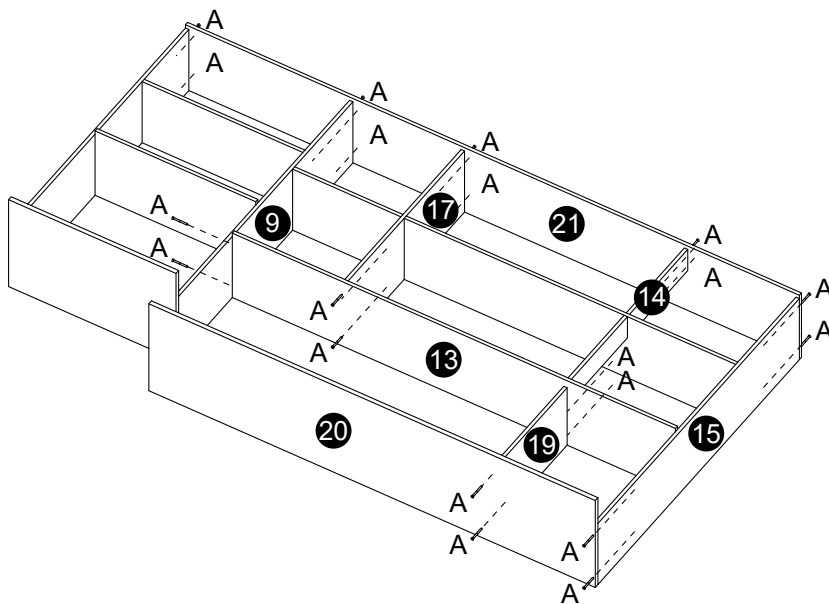

Parafuso Chato  
4,0x40mm



A 20X

PASSO 7  
PASO/STEP

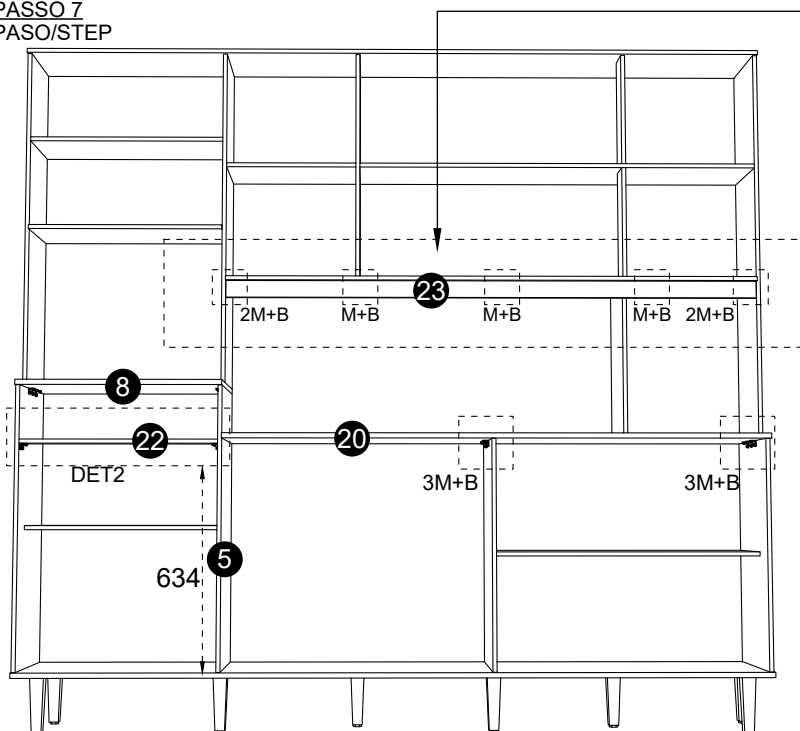

• visão de trás da vista

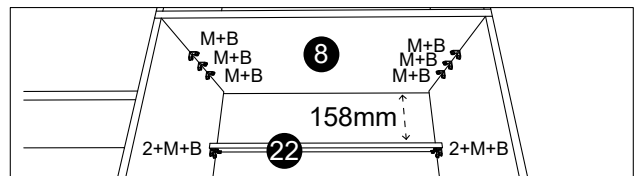
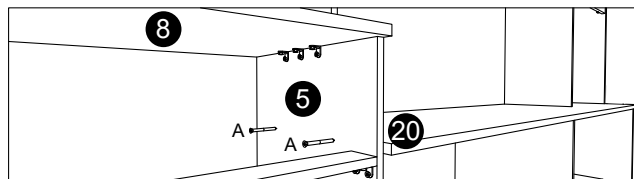
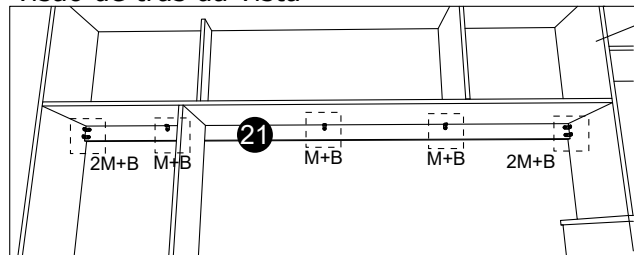

Parafuso Chato  
4,0x40mm

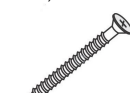

A 2X

Cantoneira  
Metálica 16x16mm



M 11X

Parafuso Chato  
3,5x12mm



B 34X

PASSO 8  
PASO/STEP

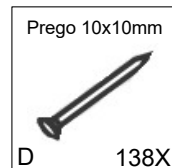
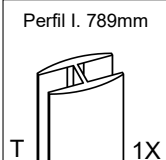
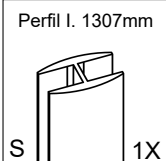
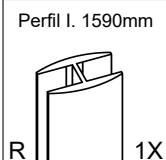
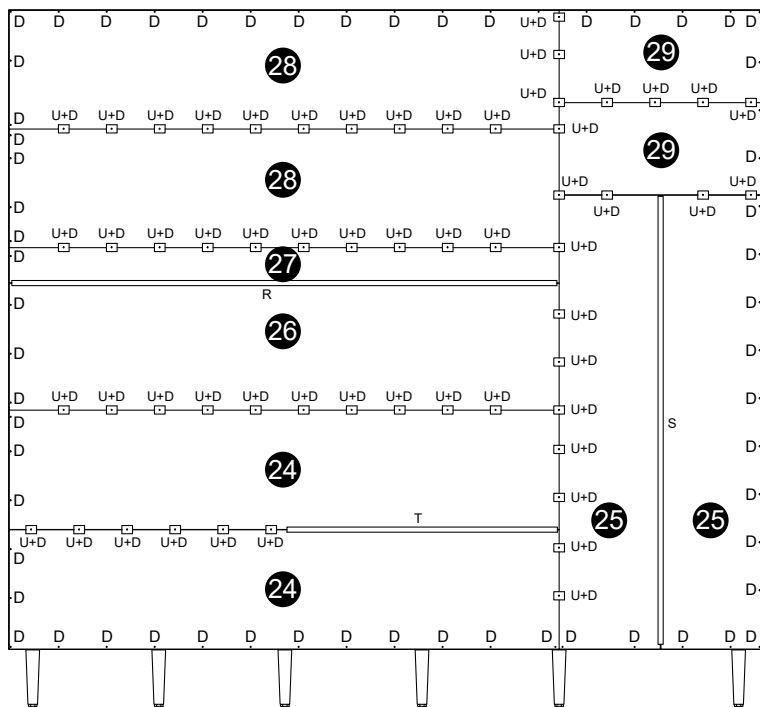

PASSO 9  
PASO/STEP

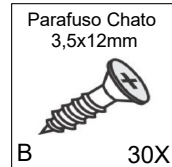
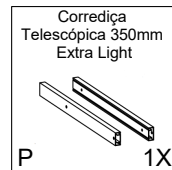
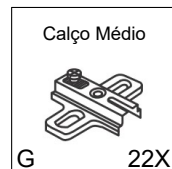
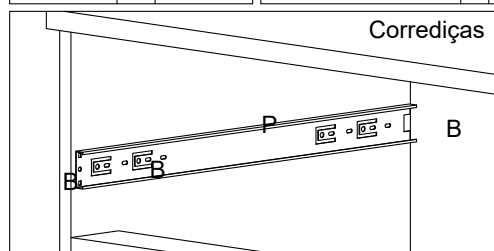
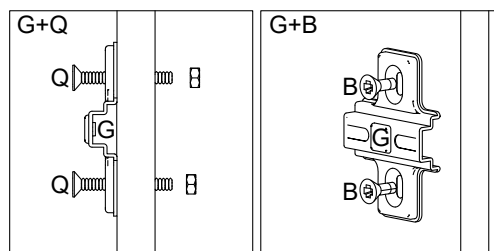
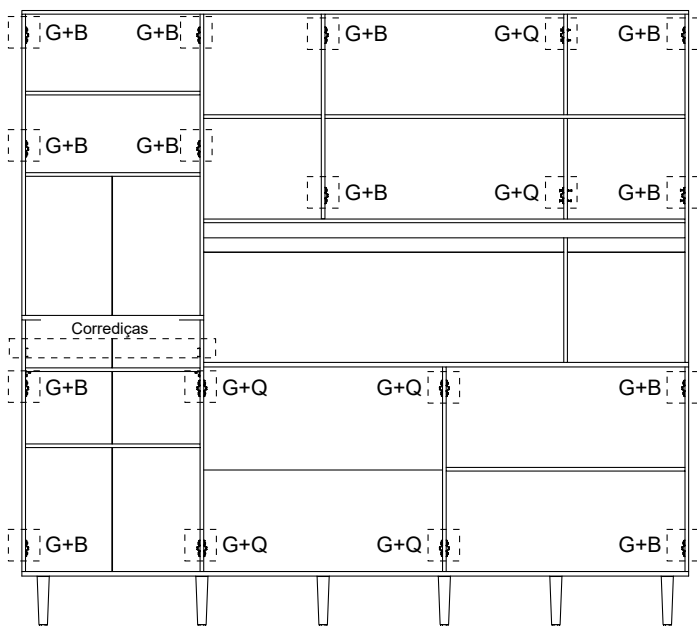

PASSO 10  
PASO/STEP

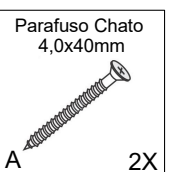
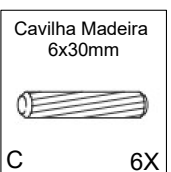
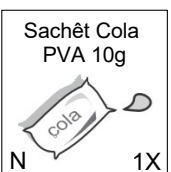
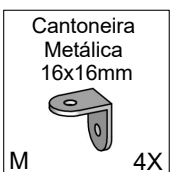
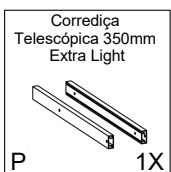
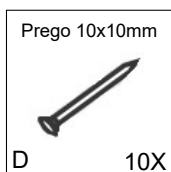
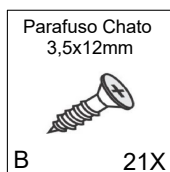
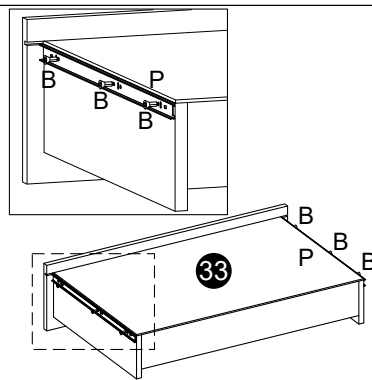
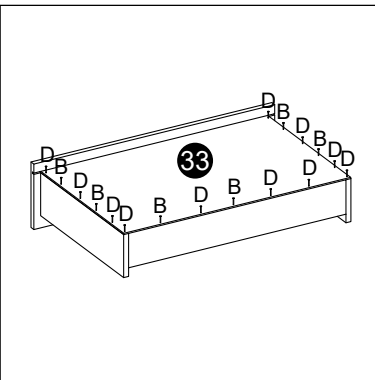
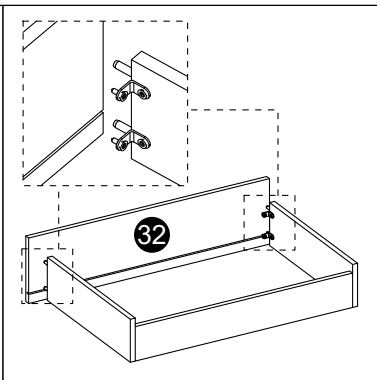
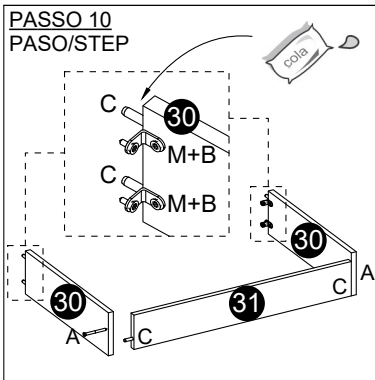

PASSO 11  
PASO/STEP

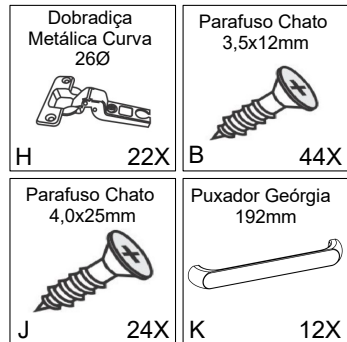
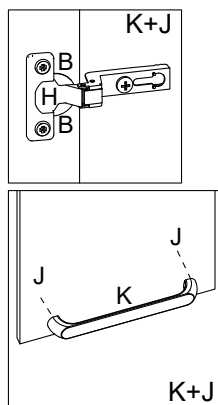
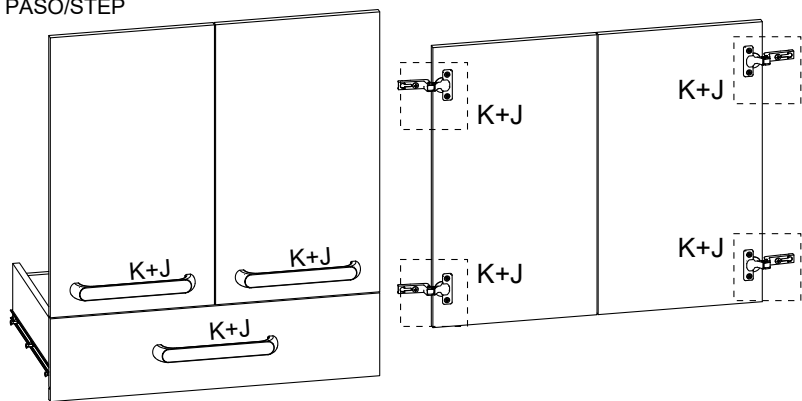

PASSO 11  
PASO/STEP

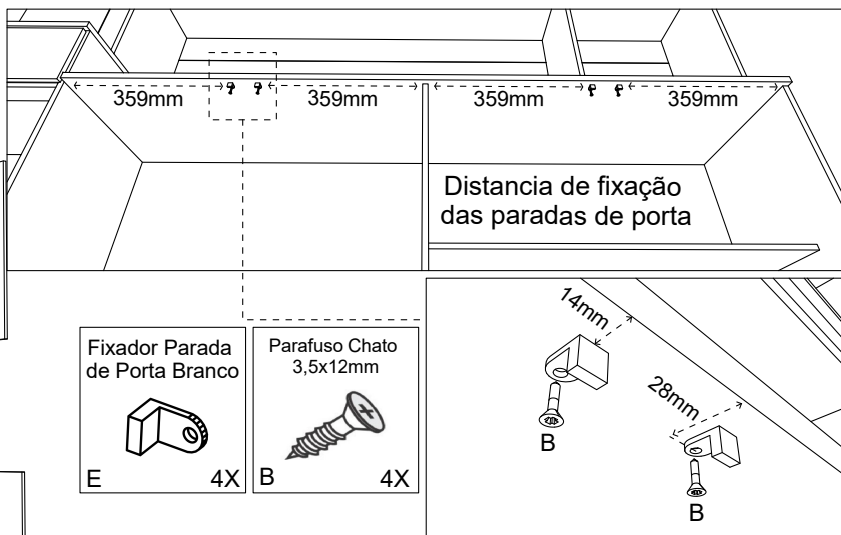
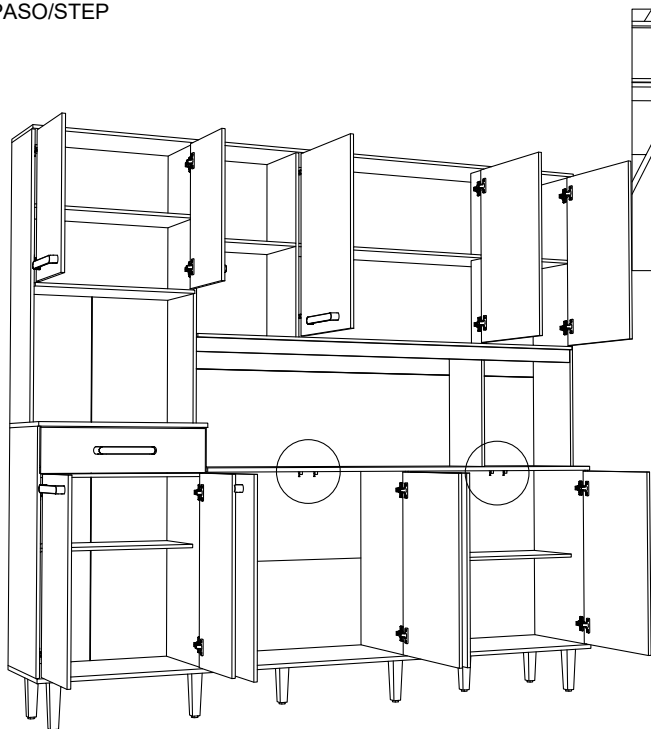

Seguir os passos para regulagem das dobradiças

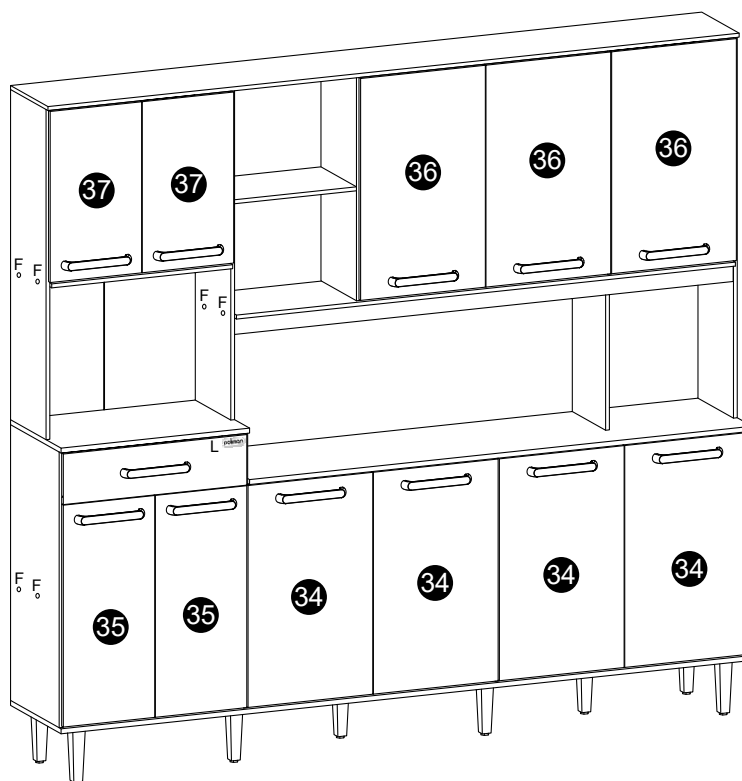
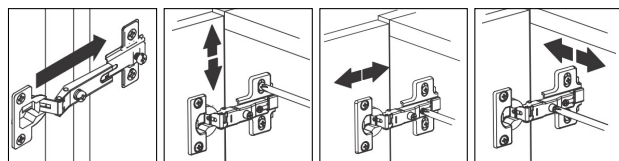

Logo 35x15mm

Tapa Furo Adesivo



L 1X F 18X



**Termo de Garantia / Renúncia de Garantia / Warranty Term**



sac@poliaman.ind.br



Data de Emissão  
Fecha de Expedición  
Date of Issue \_\_\_\_\_

Cliente / Client \_\_\_\_\_

Vendedor /Loja  
Vendedor/ Tienda  
Seller/ Store

**Dicas de conservação / Dicas para Conservación / Conservation Tips**

<p>Para limpar ou tirar manchas, utilize uma flanela umedecida em solução de água e álcool, na mesma proporção *Evite exposição ao sol.</p>	<p>Para limpiar o retirar manchas, utilice un paño humedecido en una solución de agua y alcohol, en la misma proporción. *Evite la exposición directa al sol..</p>	<p>To clean or remove stains, use a flannel moistened with water and alcohol solution in the same proportion. *Avoid sun exposure.</p>
---	--	--

Poliman Indústria e Comércio de Móveis Ltda., garante este produto (peças e mão de obra, por defeitos de fabricação), pelo prazo de noventa dias a partir da data de emissão da nota fiscal de venda do produto ao consumidor.

Poliman Indústria e Comércio de Móveis Ltda. Garantiza este producto (piezas y mano de obra debido a defectos de fabricación), por un período de noventa días a partir de la fecha de emisión de la factura de venta del producto al consumidor.

Poliman Indústria e Comércio de Móveis Ltda. Warrants this product (parts and labor due to manufacturing defects), for a period of ninety days from the date of issuance of the sales invoice of the product to the consumer.

**Termo de Garantia Contratual/ Documento de Garantía Contractual/ Contractual Warranty Term**

- 1) Apresentar este certificado de garantia acompanhado do recibo de compra do local de aquisição do produto.
- 1) Presente este certificado de garantía junto con el recibo de compra del establecimiento.
- 1) Submit this certificate of guarantee accompanied by the purchase receipt of the place of purchase of the product.
- 2) Esta garantia perderá sua validade mesmo dentro do prazo acima estipulado se:
- 2) Esta garantía perderá su validez, incluso dentro del plazo arriba estipulado en los siguientes casos:
- 2) This warranty will lose its validity even within the above time limit if:
  - O produto apresentar danos por abusos, acidente, uso diferente do indicado ou uso em condições ambientais deficientes (contato direto com água, fogo, etc.);
  - Si el producto está dañado por abuso, accidente, mal uso, uso diferente al indicado o utilizado en condiciones ambientales deficientes (contacto directo con agua, fuego, etc.);
  - The product presents damages due to ill-treatment, accident, use other than the indicated one or use in terms of environment deficient (direct contact with water, fire, etc.);
  - Os vidros e espelhos quebrarem ou trincarem após a entrega e montagem dos produtos;
  - Cuando los vidrios y espejos se rompan se rallen después de la entrega y el montaje de los productos;
  - Glasses and mirrors break after delivery and assembly of the products;
  - Quando o produto não for montado por profissionais devidamente treinados pelo revendedor;
  - Cuando el producto no sea instalado por profesionales debidamente entrenados por el concesionario;
  - When the products is not assembled by professionals properly trained by the dealer
  - Dobradiças, corrediças e puxadores somente terão sua garantia quando apresentarem defeitos de fabricação.
  - Bisagras, correderas y tiradores sólo tendrán garantía cuando presenten defectos de fabricación.
  - Hinges, slides and handles are only warranted when they have manufacturing defects
  - O consumidor exceder o limite de peso estipulado para cada parte do produto, conforme especificado no Manual de Montagem.
  - Cuando el consumidor supere el límite de peso estipulado para cada uno de los productos, tal como se especifica en el Manual de Instalación.
  - The consumer exceeds the stipulated weight limit for each part of the product as specified in the Assembly Manual.
- 3) Todo e qualquer produto com avarias deverá ser feito vistoria por parte do técnico autorizado pelo revendedor e indústria. Em hipótese alguma será realizada a troca total do produto.
- 3) Cualquier producto con daños debe ser inspeccionado por un técnico autorizado por el distribuidor y la fábrica. En ningún caso se llevará a cabo el cambio completo del producto.
- 3) Any product with faults should be inspected by the dealer authorized technician and industry. Under no circumstances will the total exchange of the product be carried out

**Código Defesa do Consumidor / Código de Defensa del Consumidor / Consumer Defense Code**

<p align="center"><b>ATENDIMENTO DE PEÇAS</b></p> <p>Art. 18. Os fornecedores de produtos de consumo duráveis ou não duráveis respondem solidariamente pelos vícios de qualidade ou quantidade que os tornem impróprios ou inadequados ao consumo a que se destinam ou lhes diminuam o valor, assim como por aqueles decorrentes da disparidade, com a indicações constantes do recipiente, da embalagem, rotulagem ou mensagem publicitária, respeitadas as variações decorrentes de sua natureza, podendo o consumidor exigir a substituição das partes viciadas.</p> <p>§ 1º Não sendo o vício sanado no prazo máximo de trinta dias, pode o consumidor exigir, alternativamente e à sua escolha:</p> <p>I - a substituição do produto por outro da mesma espécie, em perfeitas condições de uso; II - a restituição imediata da quantia paga, monetariamente atualizada, sem prejuízo de eventuais perdas e danos; III - o abatimento proporcional do preço.</p>	<p align="center"><b>REPOSICIÓN DE PIEZAS</b></p> <p>ART. 18. Los proveedores de productos de consumo duraderos o no duraderos responden, solidariamente, de los vicios de calidad o cantidad que los tornen improprios o inadecuados para el consumo al que se destinan o disminuyan su valor, así como de aquellos que sean resultado de la disparidad con las indicaciones que constan en el recipiente, embalaje, rotulado o mensaje publicitario, respetando las variaciones derivadas de la naturaleza de producto, pudiendo el consumidor exigir la sustitución de las partes viciadas.</p> <p>1º No siendo el vicio subsanado en el plazo máximo de 30 días, el consumidor puede exigir alternativamente y en su elección:</p> <p>I - La sustitución del producto por otro de la misma especie en perfectas condiciones de uso; II - La restitución inmediata del importe pagado, con actualización monetaria, sin perjuicio de las eventuales pérdidas y daños; III - La reducción proporcional del precio..</p>	<p align="center"><b>PARTS ASSISTANCE</b></p> <p>Art.18 - Suppliers of durable or non-durable consumer products are jointly and severally liable for quality or quantity which renders them unfit or unsuitable for the intended use or which diminish their value, as well as those arising from the disparity, the particulars in the container, the packaging, the labeling or the advertising message, subject to variations due to their nature, and the consumer may require the replacement of the defective parts.</p> <p>§ 1° - If the defect is not remedied within a maximum of thirty days, the consumer may, alternatively and at his choice, request: I - the replacement of the product with another of the same species, in perfect conditions of use; II - the immediate return of amount paid, monetarily updated, without prejudice to any losses and damages; III - the proportional reduction of the price.</p>
--	---	--

<p align="center"><b>GARANTIA LEGAL</b></p> <p>Art. 26. O direito de reclamar pelos vícios aparentes ou de fácil constatação caduca em:</p> <p>II - noventa dias, tratando-se de fornecimento de serviço e de produtos duráveis.</p>	<p align="center"><b>GARANTIA LEGAL</b></p> <p>Art. 26. El derecho de reclamar por los vicios aparentes o de fácil constatación caduca en:</p> <p>II - Noventa días, tratando-se de suministros de servicios y productos duraderos.</p>	<p align="center"><b>LEGAL GUARANTEE</b></p> <p>Art. 26. The right to complain about apparent or easily found defects expires in:</p> <p>II - ninety days, in the case of service provision and durable products.</p>
--	---	---