

ASPECTO MONTADO / ASSEMBLY ASPECT / ASPECTO LISTO

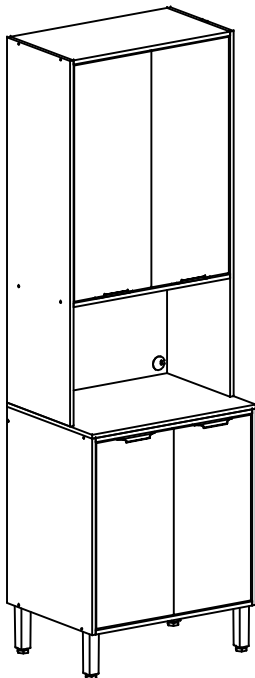

ASPECTO TRASEIRO / BOTTOM ASPECT / ASPECTO TRASERO

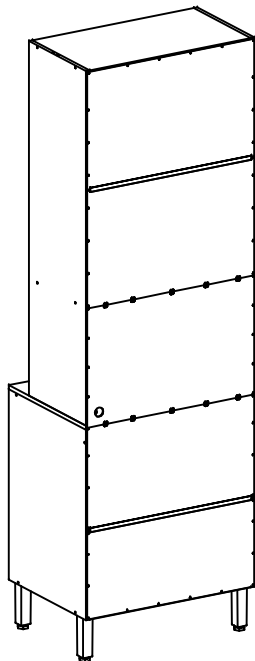

LISTA DE PEÇAS / LIST OF PIECE / LISTAJE DE PIEZAS

Nº	COD	NOME DA PEÇA / NAME OF THE PIECE / NOMBRE DE LA PIEZA	MEDIDA	QTDE	MAT. PRIMA
<b>VOLUME 01</b>					
01	116009	ACESSÓRIO DE MONTAGEM / ASSEMBLY ACCESSORY / ACCESORIO DE MONTAJE	-	01	DIVERSOS
02	903440	PERFIL H 670MM / PLASTIC PROFILE H 670MM / PERFIL H 670MM	670MM	02	PLÁSTICO
03	908640	PÉS / FEET / PATA	170MM	04	PLÁSTICO
04	116141.1327.0385	LATERAL SUP DIREITA / UPPER RIGHT LATERAL / LATERAL SUP DERECHA	1327x385x15	01	MDF
05	116142.1327.0385	LATERAL SUP ESQ / UPPER LEFT LATERAL / LATERAL SUP IZQUIERDA	1327x385x15	01	MDF
06	116120.0670.0385	CHAPÉU / HAT / CUBIERTA	670x385x15	01	MDF
07	116121.0670.0385	BASE I / BASE I / BASE I	670x385x15	01	MDF
08	116143.0670.0368	PRATELEIRA I SUP / UPPER SHELF I / REPISA I SUP	670x368x15	01	MDF
09	116144.0858.0331	PORTA SUPERIOR / UPPER DOOR / PUERTA SUP	858x331x15	02	MDF
10	116126.0670.0070	SUORTE TRASEIRO / BOTTOM SUPPORT / APOYO TRASERO	670x70x15	01	MDF
11	116127.0670.0070	SUORTE FRONTAL / FRONT SUPPORT / APOYO FRONTAL	670x70x15	01	MDF
<b>VOLUME 02</b>					
12	116123.0700.0520	TAMPO / COVER / TAPA	700x520x15	01	MDF
13	116124.0713.0520	LATERAL INF DIREITA / LOWER RIGHT LATERAL / LATERAL INF DERECHA	713x520x15	01	MDF
14	116125.0713.0520	LATERAL INF ESQUERDA / LOWER LEFT LATERAL / LATERAL INF IZQUIERDA	713x520x15	01	MDF
15	116128.0670.0503	PRATELEIRA I INF / LOWER I SHELF / REPISA I INF	670x503x15	01	MDF
16	116129.0670.0520	BASE II / BASE II / BASE II	670x520x15	01	MDF
17	116147.0695.0440	TRASEIRO SUPERIOR / UPPER BOTTOM / TRASERO SUP	695x440x03	02	MADEFIBRA
18	116145.0695.0446	TRASEIRO CENTRAL / CENTRAL BOTTOM / TRASERO CENTRAL	695x446x03	01	MADEFIBRA
19	116131.0695.0382	TRASEIRO INF MAIOR / UPPERSIZED LOWER BOTTOM / TRASERO INF MAYOR	695x382x03	01	MADEFIBRA
20	116132.0695.0331	TRASEIRO INF MENOR / DOWNSIZED LOWER BOTTOM / TRASERO INF MENOR	695x331x03	01	MADEFIBRA
<b>VOLUME 03</b>					
21	116130.0675.0331	PORTA INFERIOR / LOWER DOOR / PUERTA INF	675x331x15	02	MDP - BP

CÓDIGOS IDENTIFICADOS NO TOPO DA MAIORIA DAS PEÇAS DO PRODUTO.  
THESE CODES ARE IDENTIFIED ON THE SIDE OF MOST PARTS OF THE PRODUCT.  
CÓDIGO IMPRESO EN EL CANTO CRUDO DE LA MAYORIA DE LAS PIEZAS.

**ATENÇÃO / ATTENTION / ATENCIÓN:**

- A LIMPEZA DO MÓVEL DEVE SER EFETUADA SOMENTE COM PANO MACIO E MODERADAMENTE UMEDECIDO COM ÁGUA PURA OU SOLUÇÃO COM SABÃO NEUTRO.
- FOR CLEANING, USE ONLY A SOFT CLOTH MODERATELY MOISTENED WITH PURE WATER OR A SOLUTION WITH NEUTRAL SOAP.
- PARA LIMPIEZA DEL MUEBLE USAR UN PAÑO SUAVE Y MODERADAMENTE HUMEDECIDO CON AGUA PURA O SOLUCIÓN CON JABÓN NEUTRO.
- NÃO UTILIZE PRODUTOS QUÍMICOS OU ABRASIVOS, TAIS COMO: CERA, ÁLCOOL, DETERGENTES, TINNER.
- DO NOT USE CHEMICAL OR ABRASIVE PRODUCTS. FOR EXAMPLE: WAX, ALCOHOL, DETERGENT, THINNER.
- NO APLICAR PRODUCTOS QUÍMICOS O ABRASIVOS TALES COMO: CERAS, ALCOHOL, DISOLVENTES O DETERGENTES.
- AO SOLICITAR ASSISTÊNCIA TÉCNICA, INFORME O CÓDIGO DO PRODUTO, A COR E O CÓDIGO DA PEÇA CORRETAMENTE.
- WHEN REQUESTING TECHNICAL ASSISTENCE, INFORM THE PRODUCT CODE, THE COLOR AND THE PIECE CODE CORRECTLY.
- SI NECESITAR REPUESTOS, INFORMAR EL CÓDIGO DEL PRODUCTO, EL COLOR Y EL CÓDIGO DE LA PIEZA.











- PESSOAS NECESSÁRIAS P/ MONTAGEM.
- REQUIRED PEOPLE FOR ASSEMBLY.
- CANTIDAD DE PERSONAS NECESSARIAS P/ ARMAR.



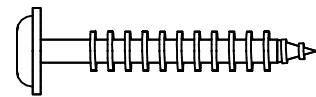

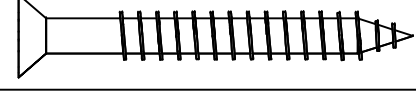
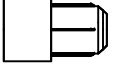
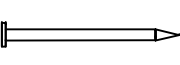
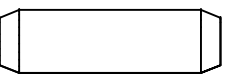
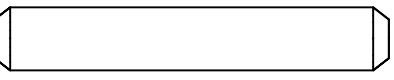
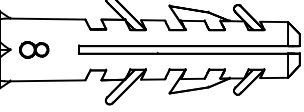

1 PESSOA  
1 PERSONA  
1 PERSON

**LISTA DE ACESSÓRIO / ACCESSORY LIST / LISTAJE DE ACCESORIO - 1X1**

		<b>A 64</b> 911268 - PARAFUSO 3,5X12 CHATA 6.1
		<b>B 06</b> 909192 - PARAF. 3,5X25 CABEÇA CHATA
		<b>C 04</b> 903557 - PARAF. 5,0X35 FLANGEADO
		<b>D 20</b> 903566 - PARAF. 5,0X40
		<b>E 02</b> 903563 - PARAF. 6,0X50
		<b>F 08</b> 904980 - SUPORTE DE PRATELEIRA 8X10
		<b>G 68</b> 904801 - PREGO 09X09
		<b>H 20</b> 902913 - CAVILHA 8X30
		<b>I 02</b> 902915 - CAVILHA 8X50
		<b>J 02</b> 900053 - BUCHA 08

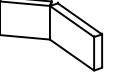
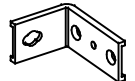
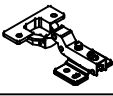
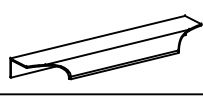
**LISTA DE ACESSÓRIO / ACCESSORY LIST / LISTAJE DE ACCESORIO**

	<b>K 02</b> 902900 - CANTONEIRA PARA VISTA		<b>O 10</b> 900456 - FIXADOR P/ FUNDO
	<b>L 02</b> 901635 - FIXADOR L CAPA PLÁSTICA		<b>P 02</b> 903341 - FIXADOR L CANTONEIRA METÁLICA
	<b>M 08</b> 915273 - DOBRADIÇA SLOW SUPER CURVA 35MM		<b>Q 04</b> 913355 - PUXADOR
	<b>N 01</b> 900970 - PASSA FIO		

**ESTRUTURA / STRUCTURE / ESTRUCTURA**

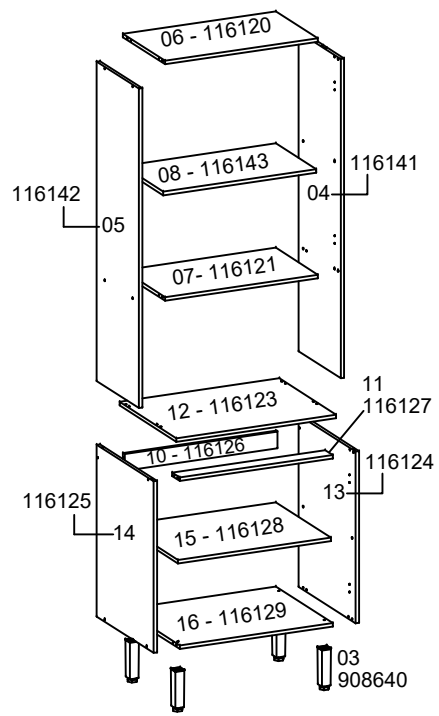

**FRENTE / FRONT / FRENTE**

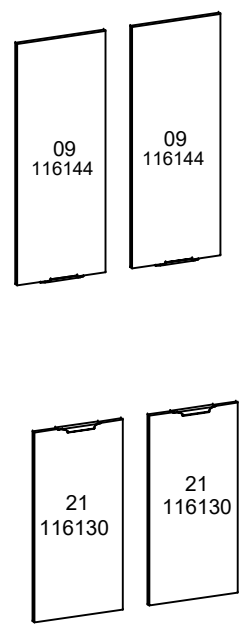

**TRASEIRO / BOTTOM / TRASERO**

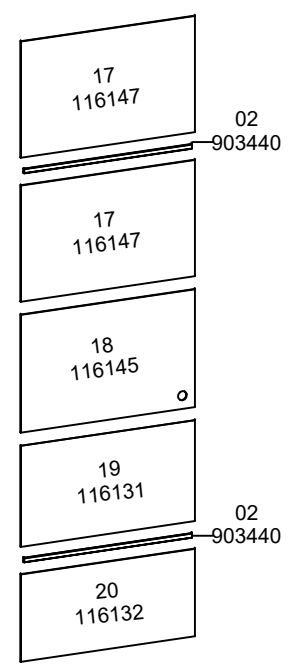

**FERRAMENTAS NECESSÁRIAS P/ MONTAGEM.**  
(NÃO SÃO FORNECIDAS)  
**REQUIRED TOOLS FOR ASSEMBLY.**  
(NOT PROVIDED)  
**HERRAMIENTAS NECESARIAS.**  
(NO PROPORCIONADAS)

TRENA  
Measuring Tape  
Cinta Métrica

MARTELO  
Hammer  
Martillo

PARAFUSADEIRA /  
FURADEIRA  
Screw Gun / Drill  
Atornillador / Taladro

CHAVE PHILIPS  
Philips Screw Driver  
Destornillador Philips

CHAVE DE FENDA  
Screw Driver  
Destornillador

NÍVEL  
Level  
Nivel

① COLOCAÇÃO DAS DOBRADIÇAS E PUXADORES.  
HINGE AND HANDLES ATTACHMENT.  
FIJACIÓN DE LAS MANIJAS Y BISAGRA .

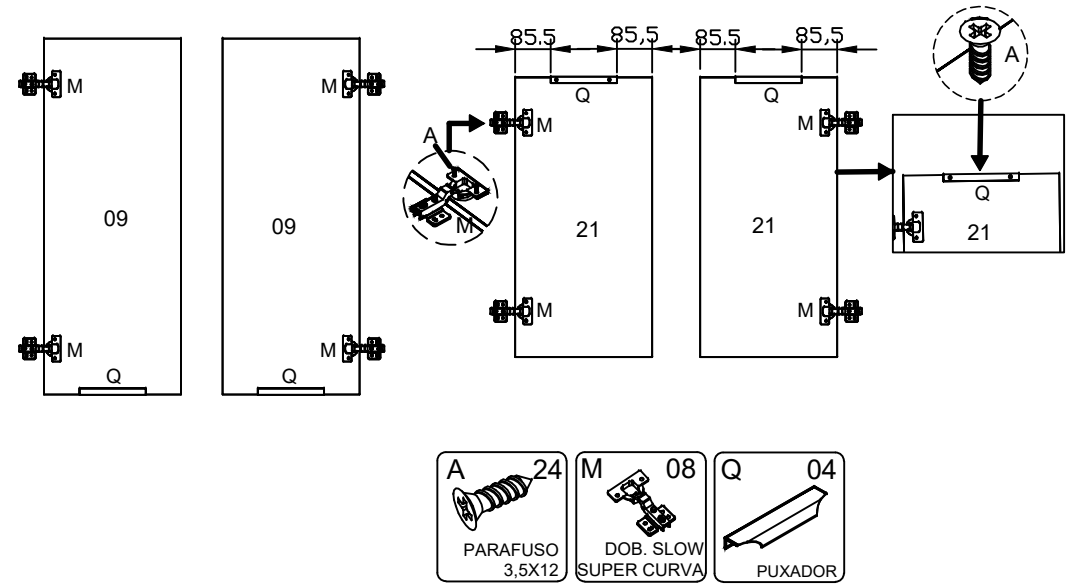

③ MONTAGEM DA ESTRUTURA SUPERIOR.  
UPPER STRUCTURE ASSEMBLY.  
MONTAJE DE LA ESTRUCTURA SUPERIOR.

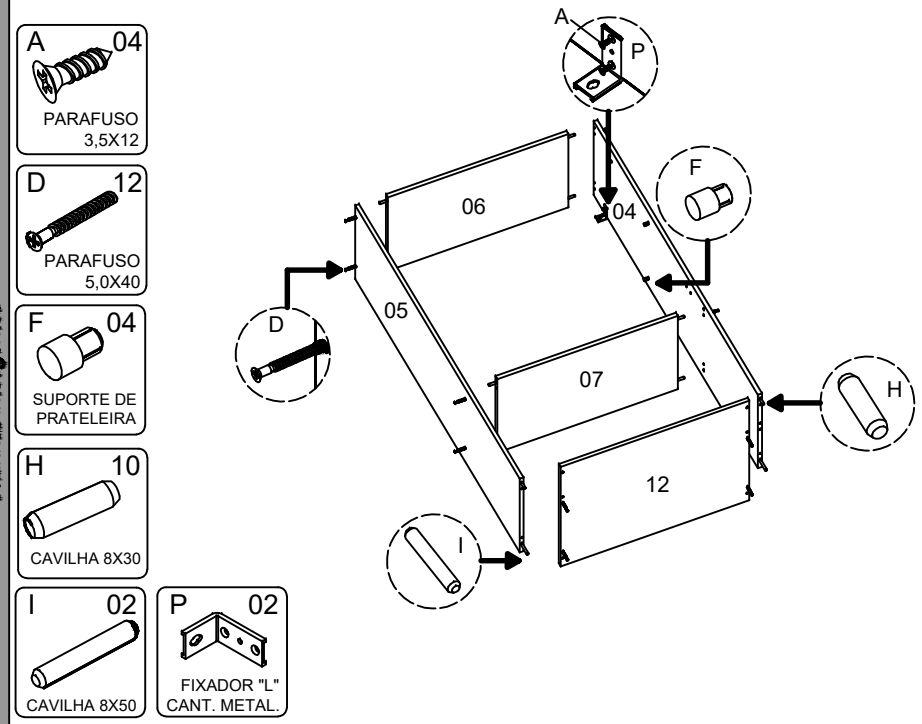

② MONTAGEM DA ESTRUTURA INFERIOR.  
LOWER STRUCTURE ASSEMBLY.  
MONTAJE DE LA ESTRUCTURA INFERIOR.

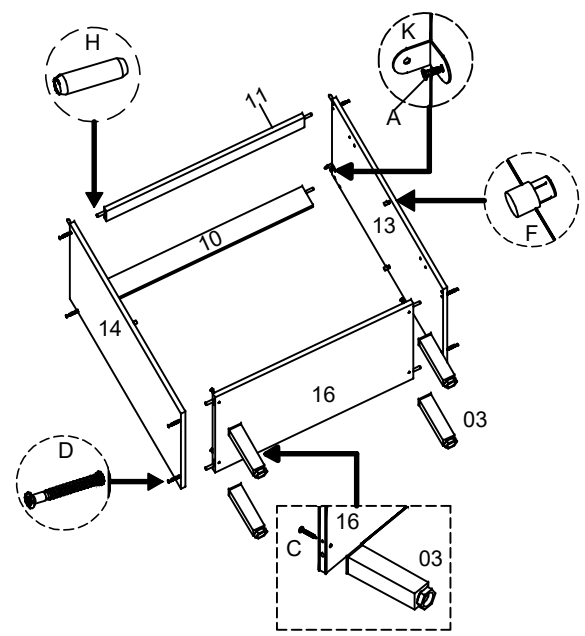

④ FIXAÇÃO DA ESTRUTURA INF. C/ A SUP.  
UPPER STRUCTURE ATTACHMENT INTO LOWER.  
FIJACIÓN DE LA ESTRUCTURA INF. CON LA SUP.

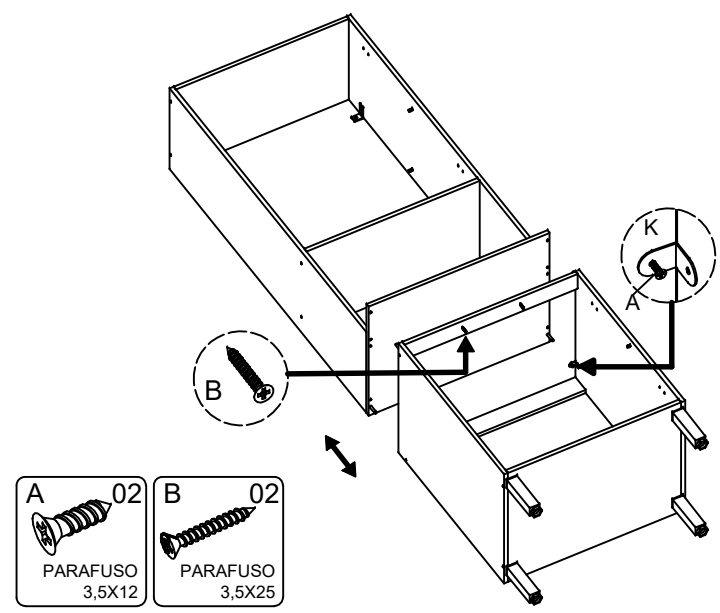

- A 02  
PARAFUSO 3,5X12
- C 04  
PARAFUSO 5,0X35
- D 08  
PARAFUSO 5,0X40
- F 04  
SUPORTE DE PRATELEIRA
- H 10  
CAVILHA 8X30
- K 02  
CANTONEIRA METALICA

⑤ FIXAÇÃO DOS TRASEIROS.  
BOTTOMS ATTACHMENT.  
FIJACIÓN DE LOS TRASEROS.

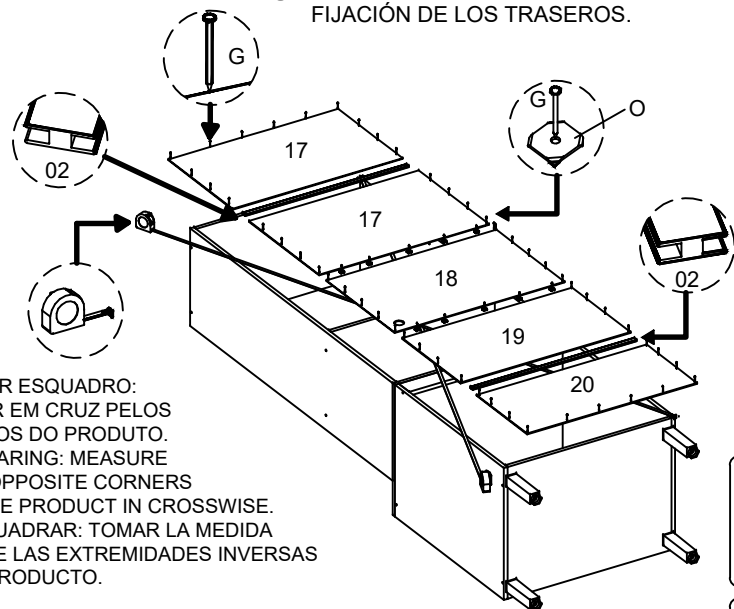

- TIRAR ESQUADRO: MEDIR EM CRUZ PELOS CANTOS DO PRODUTO.  
- SQUARING: MEASURE THE OPPOSITE CORNERS OF THE PRODUCT IN CROSSWISE.  
- ESCUADRAR: TOMAR LA MEDIDA ENTRE LAS EXTREMIDADES INVERSAS DEL PRODUCTO.

\* LIMITE DE PESO MÁXIMO SUPORTADO (KG).  
\* WEIGHT CAPACITY (KG).  
\* CAPACIDAD DE PESO (KG).



⑥ COLOCAÇÃO DAS PORTAS E PRATELEIRA I.  
DOORS AND SHELF I PLACEMENT.  
COLOCACIÓN DE LAS PUERTAS Y REPISA I.

- VERIFICAR O NÍVEL DO PRODUTO, SE NECESSÁRIO FAZER AJUSTE DOS PÉS REGULÁVEIS.  
- CHECK THE PRODUCT'S LEVELING, IF IT'S NECESSARY MAKE AN ADJUSTMENT ON THE ADJUSTABLE FEET.  
- VERIFICAR LA NIVELACIÓN DEL PRODUCTO, SI ES NECESARIO REALIZAR UN AJUSTE EN LOS PIES REGULABLES.

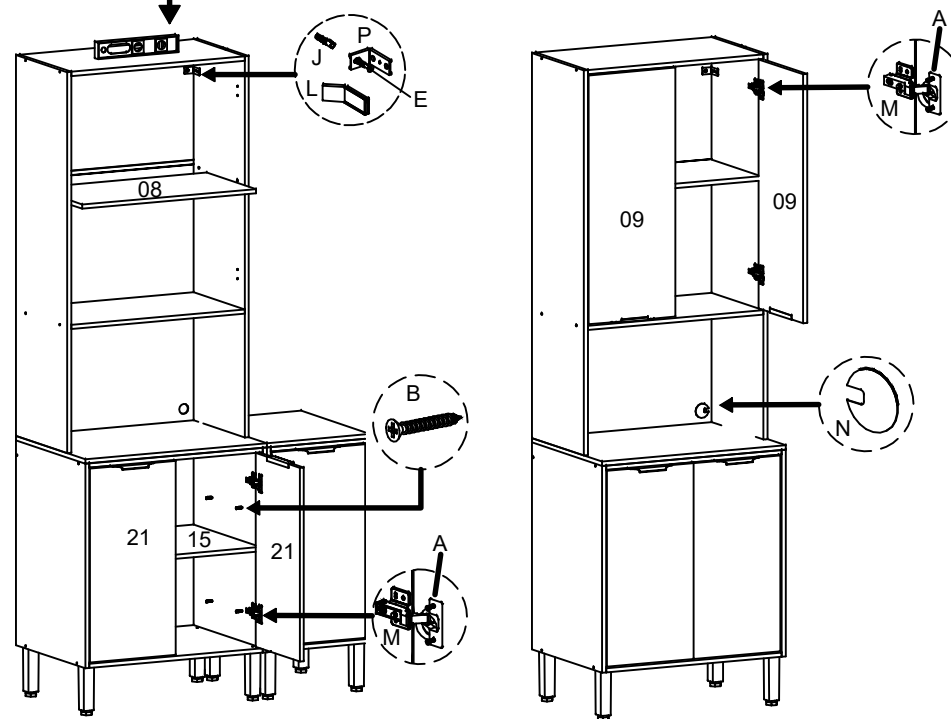

- PARA UNIÃO DOS MÓDULOS, FAZER USO DO PARAF. 3,5X25 (B).  
- FOR THE MODULES UNION, USE SCREW 3,5X25 (B).  
- PARA LA UNIÓN DE LOS MÓDULOS, USE EL TORNILLO 3,5X25(B).

- INFORMAÇÃO AO MONTADOR: USAR PARAFUSADEIRA NO TORQUE BAIXO!  
- INFORMATION TO THE ASSEMBLER: USE THE CORDLESS DRILL AT LOW TORQUE.  
- INFORMACIÓN AL ARMADOR: UTILIZAR ATORNILLADOR EN TORQUE FLACO.

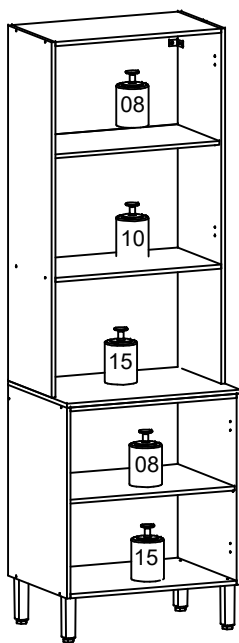
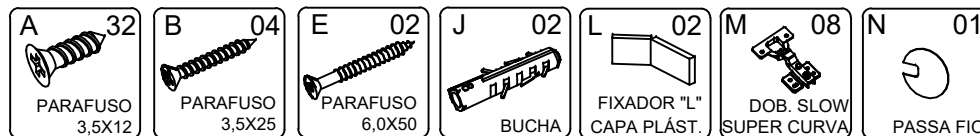

- CONSIDERAR UM PESO BEM DISTRIBUÍDO POR TODO O PRODUTO.  
- CONSIDER A WELL DISTRIBUTED WEIGHT IN ALL THE PRODUCT.  
- CONSIDERAR UN PESO BIEN DISTRIBUIDO EN TODO EL PRODUCTO.