

# ASSEMBLY INSTRUCTIONS MANUAL DE MONTAGEM / INSTRUCCIONES DE ARMADO

BASE CABINET 2 DOORS 3 DRAWERS  
BALCAO 2P 3G  
GABINETE 2 PUERTAS 3 CAJONES

Reference  
Referência  
Referencia **250490** | Revise  
| Revisão  
| Revisión **00**

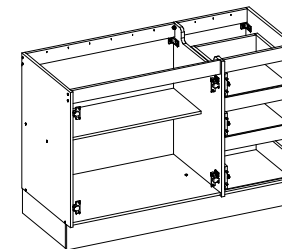

**YOU WILL NEED  
VOCÊ VAI PRECISAR DE / USTED NECESITARÁ**

Tools not supplied  
Ferramentas não fornecidas / Herramientas no incluidas

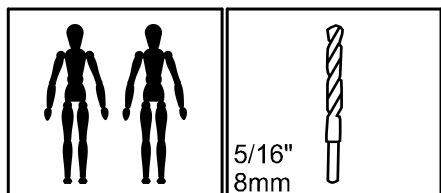

2 People  
2 Pessoas  
2 Personas

Drill bit  
Broca  
Taladro

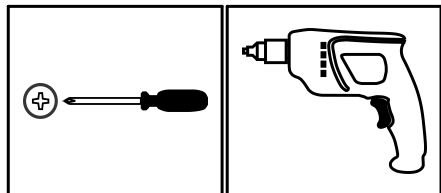

Screwdriver Phillips  
Chave Phillips  
Destornillador cruz

Drill machine  
Furadeira  
Taladro

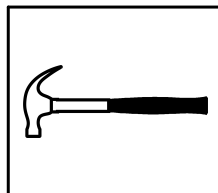

Hammer  
Martelo  
Martillo

 MAXIMUM RECOMMENDED WEIGHT BEING THIS EVENLY DISTRIBUTED.  
PESO MÁXIMO RECOMENDADO SENDO ESTE DISTRIBUÍDO UNIFORMEMENTE.  
PESO MÁXIMO RECOMENDADO SIENDO ESTE UNIFORMEMENTE DISTRIBUIDO.

	LB	KG
D	11	5
F	22	10

**PARTS IDENTIFICATION  
IDENTIFICAÇÃO DAS PEÇAS / IDENTIFICACIÓN DE LAS PIEZAS**

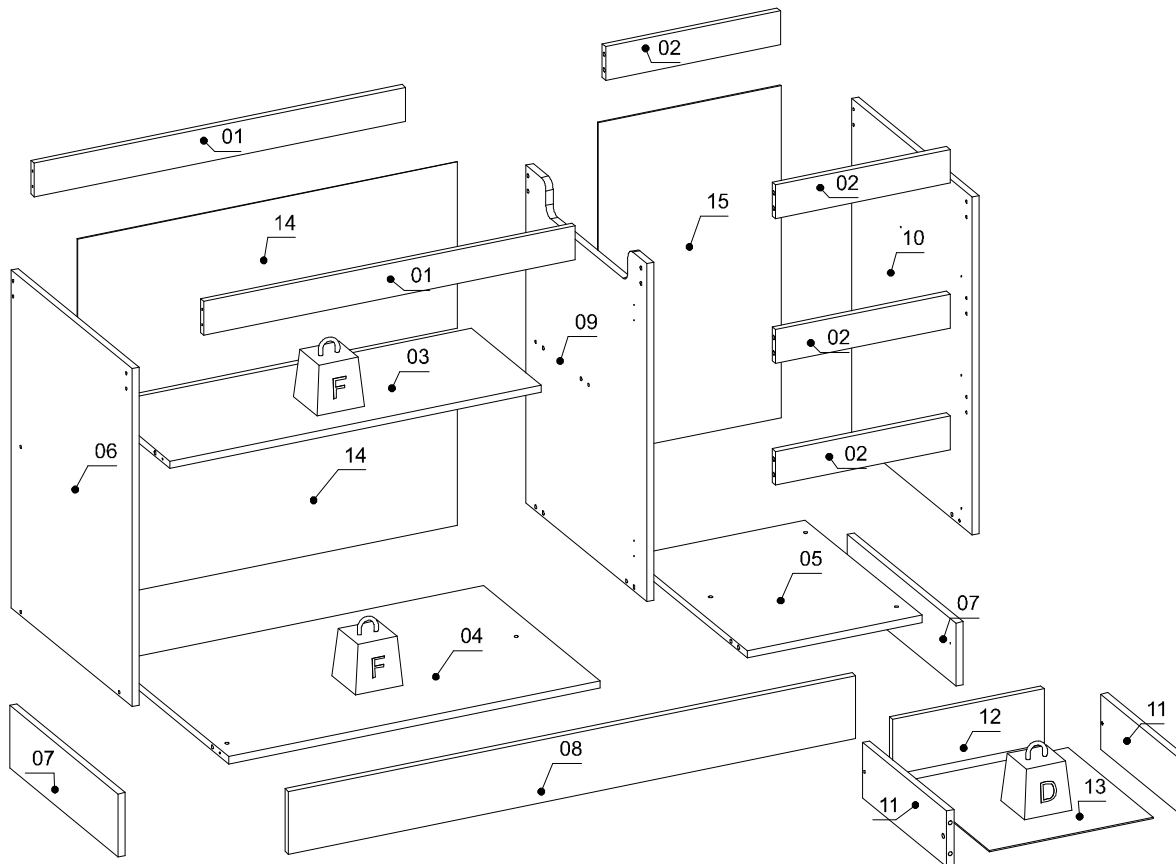

Nº	Measures_Inches	Medidas_cm	Qty./Qtd.
01	30 7/8 x 2 3/4 x 5/8	78.5 x 7.0 x 1.5	2
02	14 1/2 x 2 3/4 x 5/8	36.9 x 7.0 x 1.5	4
03	30 7/8 x 11 5/8 x 5/8	78.5 x 29.4 x 1.5	1
04	30 7/8 x 19 3/8 x 5/8	78.5 x 49.3 x 1.5	1
05	14 1/2 x 19 3/8 x 5/8	36.9 x 49.3 x 1.5	1
06	27 1/2 x 20 1/8 x 5/8	70.0 x 51.0 x 1.5	1
07	18 1/8 x 5 1/8 x 5/8	45.9 x 13.0 x 1.5	2
08	47 1/4 x 5 1/8 x 5/8	119.9 x 13.0 x 1.5	1
09	27 1/2 x 20 1/8 x 5/8	70.0 x 51.0 x 1.5	1
10	27 1/2 x 20 1/8 x 5/8	70.0 x 51.0 x 1.5	1
11	14 x 4 1/2 x 5/8	35.5 x 11.5 x 1.5	6
12	12 5/8 x 4 1/2 x 5/8	32.0 x 11.5 x 1.5	3
13	14 1/8 x 13 5/8 x 1/8	36.0 x 34.6 x 0.3	3
14	31 5/8 x 13 1/2 x 1/8	80.2 x 34.4 x 0.3	2
15	27 1/8 x 15 1/4 x 1/8	68.8 x 38.6 x 0.3	1

## IDENTIFICATION OF ACCESSORIES IDENTIFICAÇÃO DOS ACESSÓRIOS/ IDENTIFICACIÓN DE ACCESORIOS



The separation of the accessories before you start the assembly will facilitate the same. In case of doubt on the size of the screws and bolts, use the ruler at the bottom of the page.  
 A separação dos acessórios antes de iniciar a montagem facilitará a mesma. Em caso de dúvida no tamanho dos parafusos e cavilhas, utilize a régua ao final da página.  
 La separación de los accesorios antes de comenzar el armado facilitará el mismo. En caso de duda sobre el tamaño de los tornillos y taquetes, utilice la regla al pie de página.

A		Flanged head screw Parafuso flangeado / Tornillo de cabeza flangeada	5,0x60 mm	3
A3		Trapeze Trapézio / Trapecio	-	6
B3		Bushing Bucha expansiva / Tapón	8x50 mm	3
C1		Metal claw Garra de metal / Garra metal	-	9
D		Flat head screw Parafuso chato / Tornillo de cabeza plana	4,0x40 mm	6
E		Wooden dowel Cavilha / Taquete	8x30 mm	24
F		Wooden dowel Cavilha / Taquete	8x50 mm	6
K		Double minifix screw Haste minifix dupla / Tornillo minifix doble	60mm	2
L		Drum lock Tambor minifix / Tambor minifix	12 mm	4
L1		Flat head screw Parafuso chato / Tornillo de cabeza plana	7,0x40 mm	6
L3		Plastic Foot Sapata / Pie Plástico	-	6
L9		Flat head screw Parafuso chato / Tornillo de cabeza plana	3,5x12 mm	30
L17		Telescopic slide Corrediça telescópica / Corredera telescópica	350 mm	6
M12		Metal hinge super high Dobradiça super alta / Bisagra alta	35 mm	4
N		Nail Prego / Clavo	10x10	87
N4		Loop Presilha / Presilla	-	6
N5		Support "L" Suporte "L" / Soporte "L"	-	3
O		Flat head screw Parafuso chato / Tornillo de cabeza plana	4,5x45 mm	20
P		Pan head screw Parafuso panela / Tornillo de pan	4,5x25 mm	6
S		Pan head screw Parafuso panela / Tornillo de pan	3,5x14 mm	48
Y18		Zamac bracket Cantoneira zamac/ Soporte de zamac	13x13 mm	6

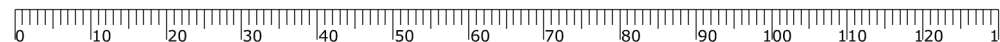

## PRE-ASSEMBLE PRÉ-MONTAGEM / PRE ARMADO

01

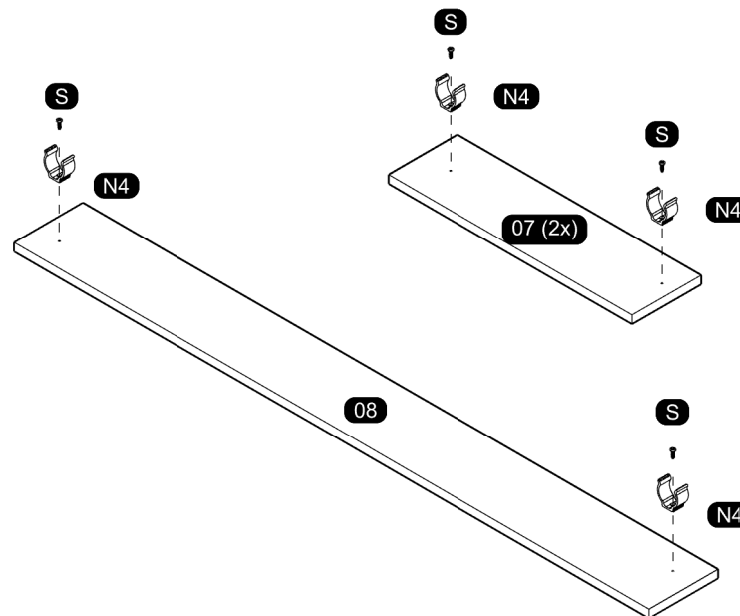

02

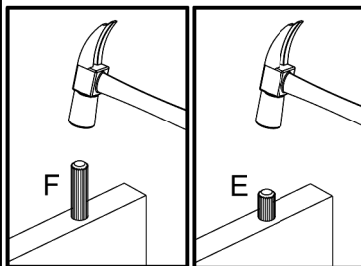
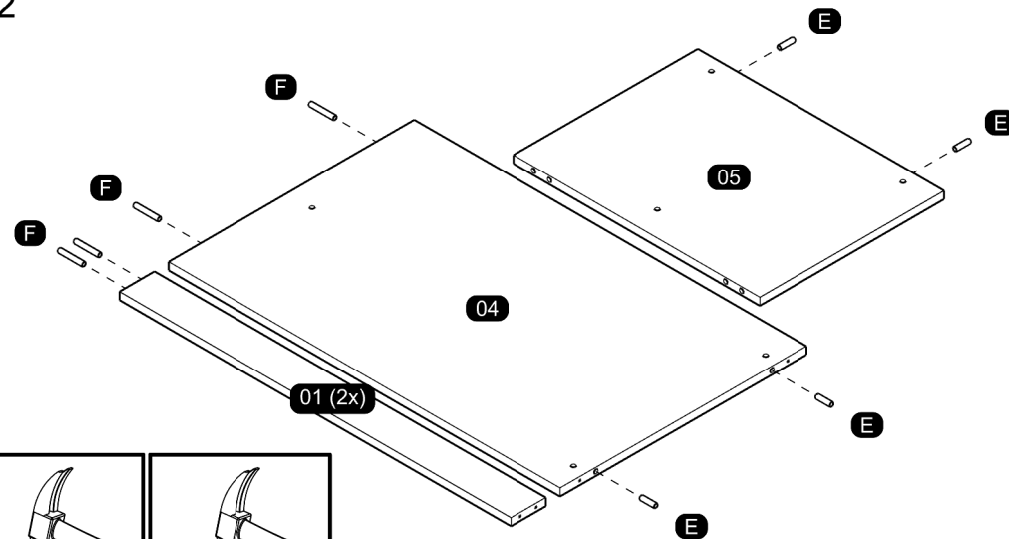

03

SEPARATE THE TWO PARTS OF THE METAL SLIDE TO THE ASSEMBLY FOLLOWING THE INSTRUCTIONS BELOW.  
SEPARE AS DUAS PARTES DA CORREDIÇA METÁLICA PARA A MONTAGEM SEGUINDO AS INSTRUÇÕES ABAIXO.  
SEPARAR LAS DOS PARTES DE LA CORREDERA DE METAL PARA EL ARMADO Y SEGUIR LAS INSTRUCCIONES ABAJO.

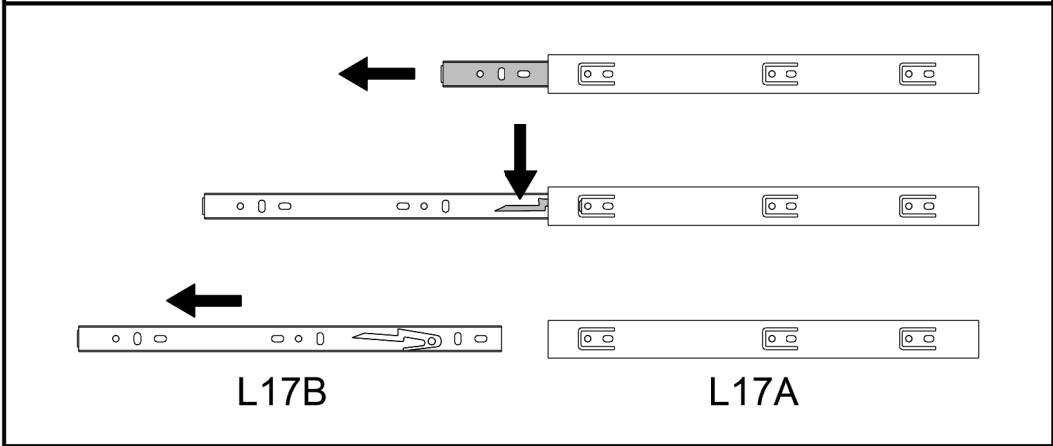

05

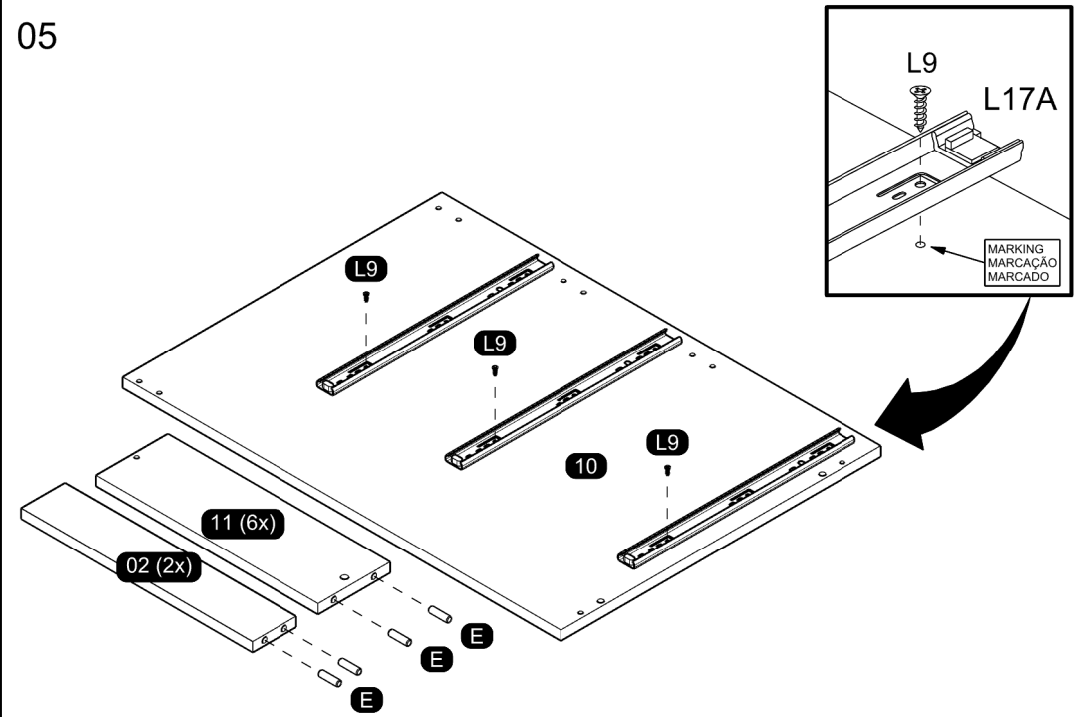

04

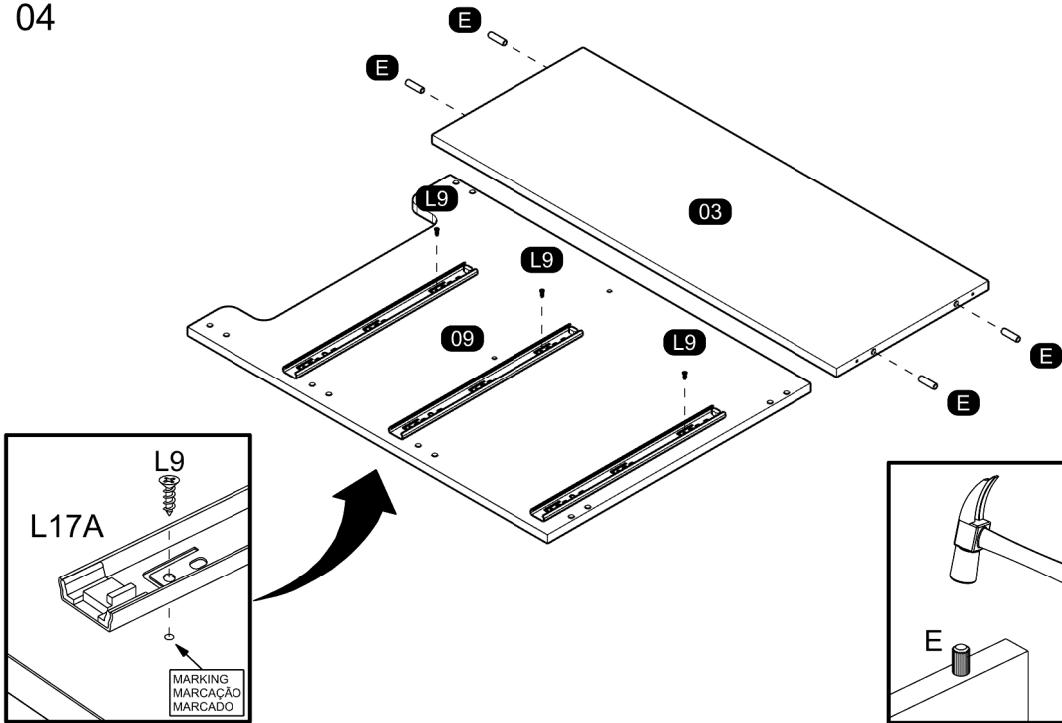

### ASSEMBLY MONTAGEM / ARMADO

06

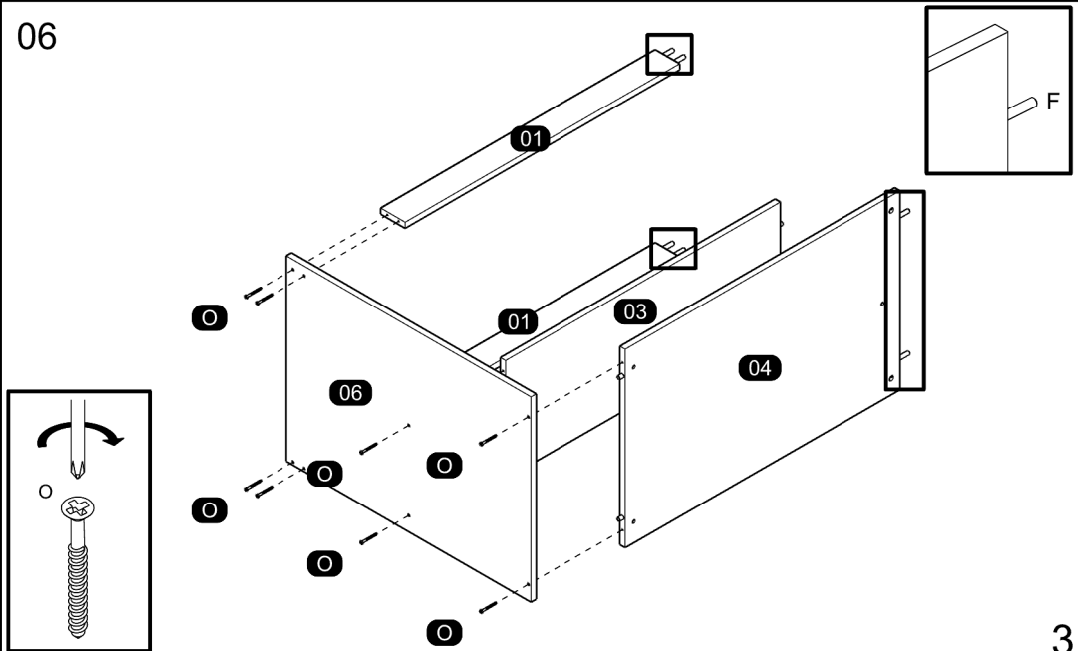

07

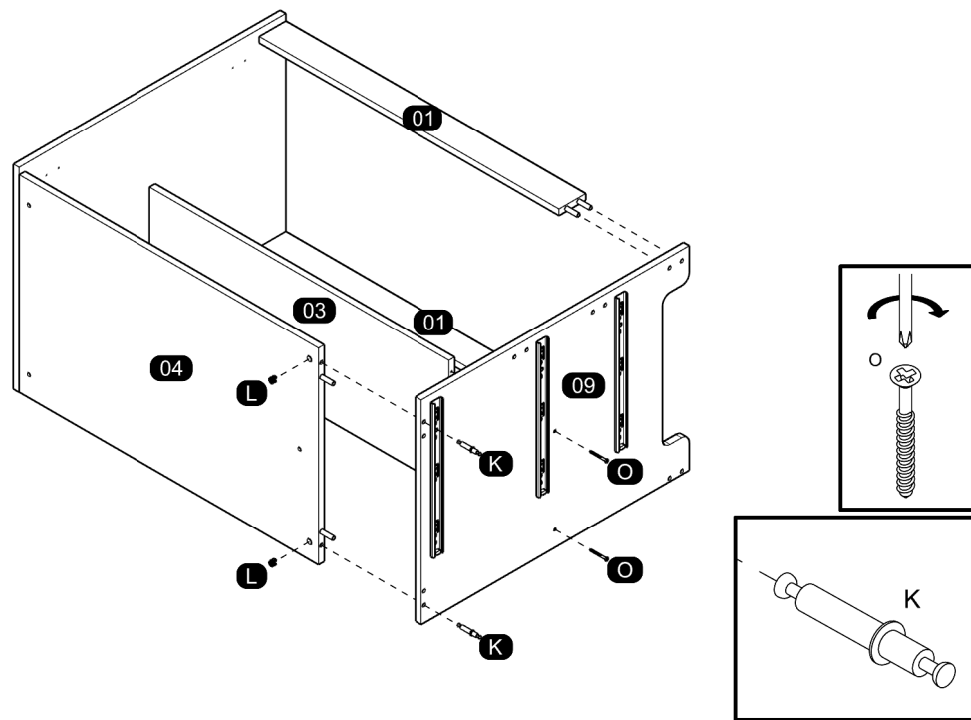

09

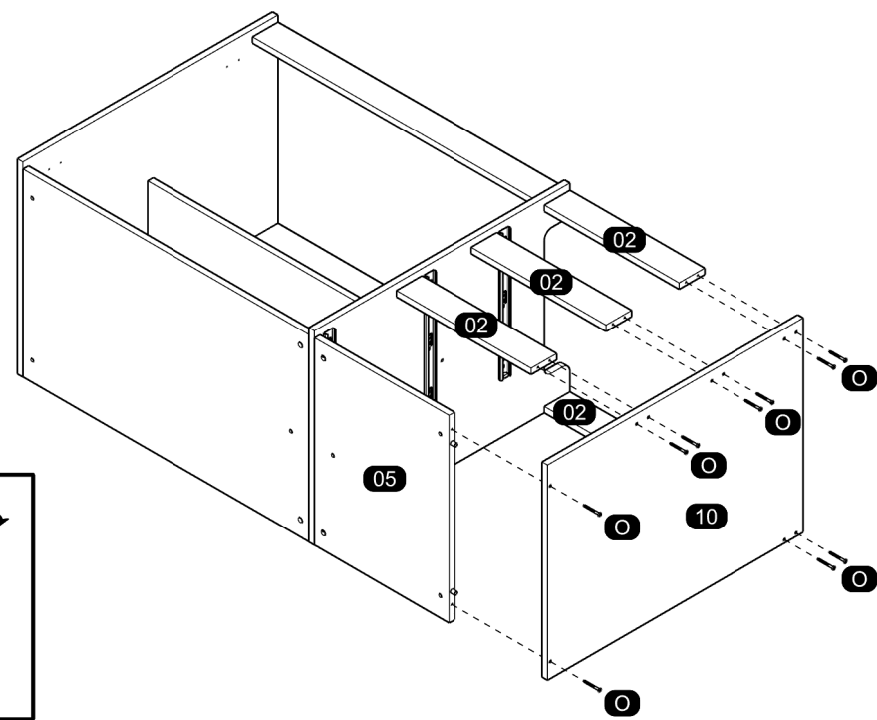

08

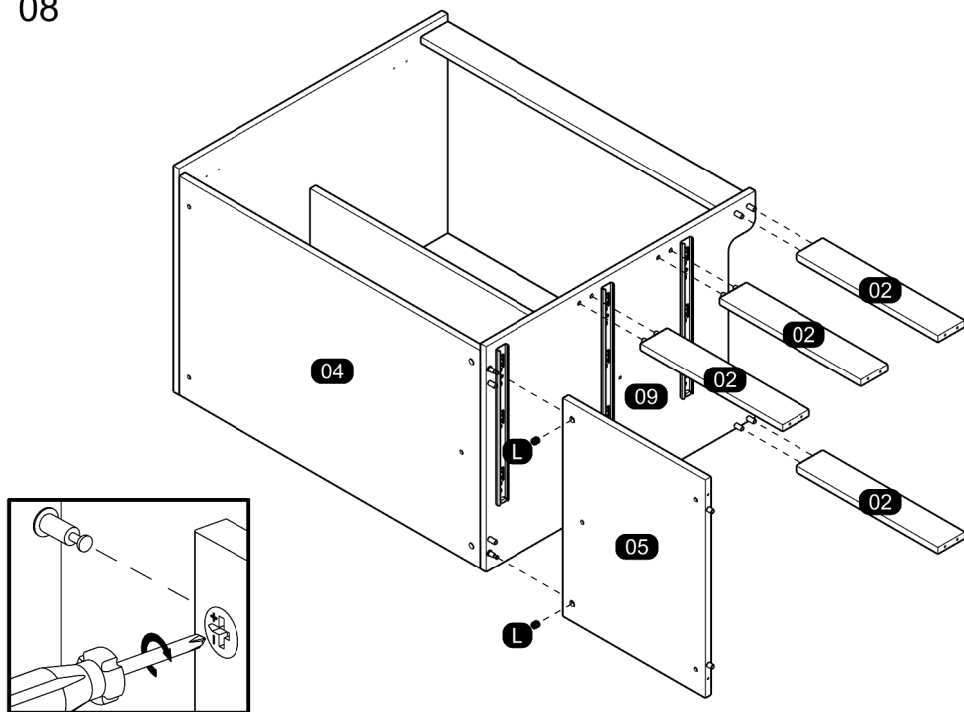

10

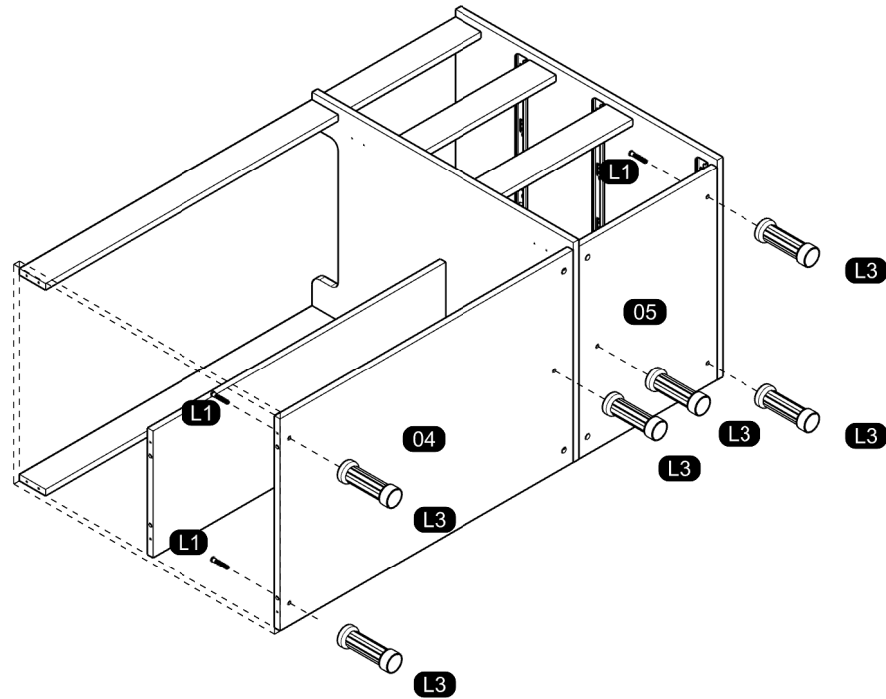

11

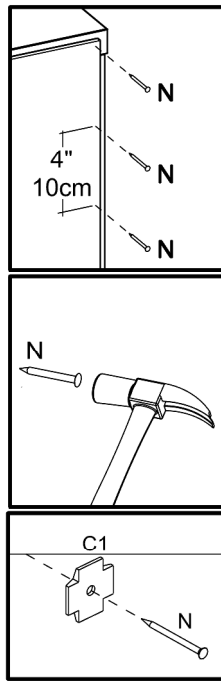
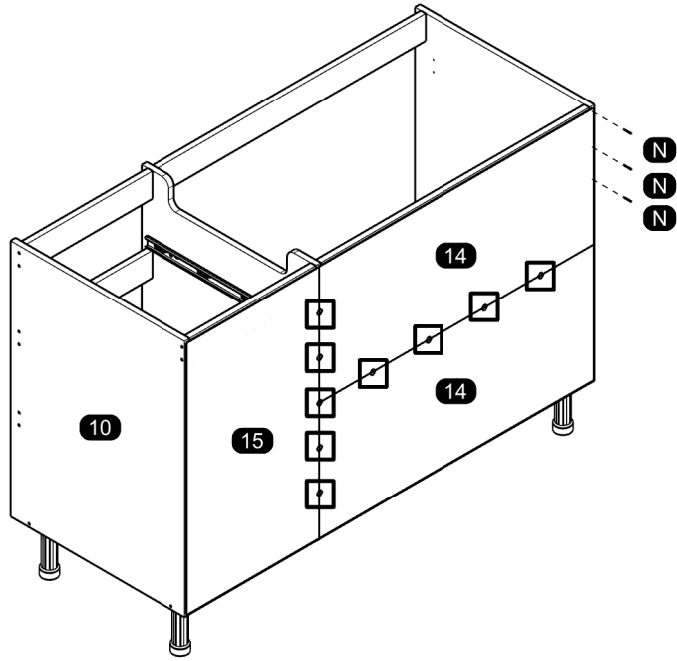

13

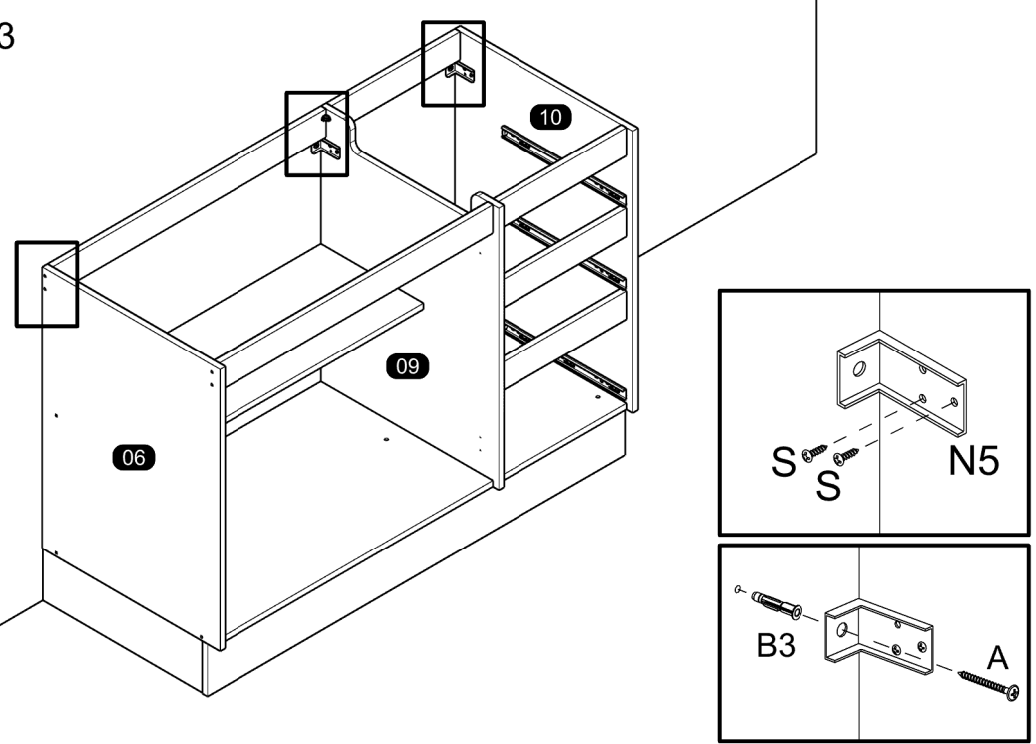

12

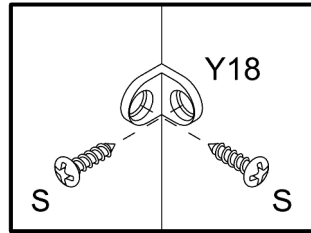
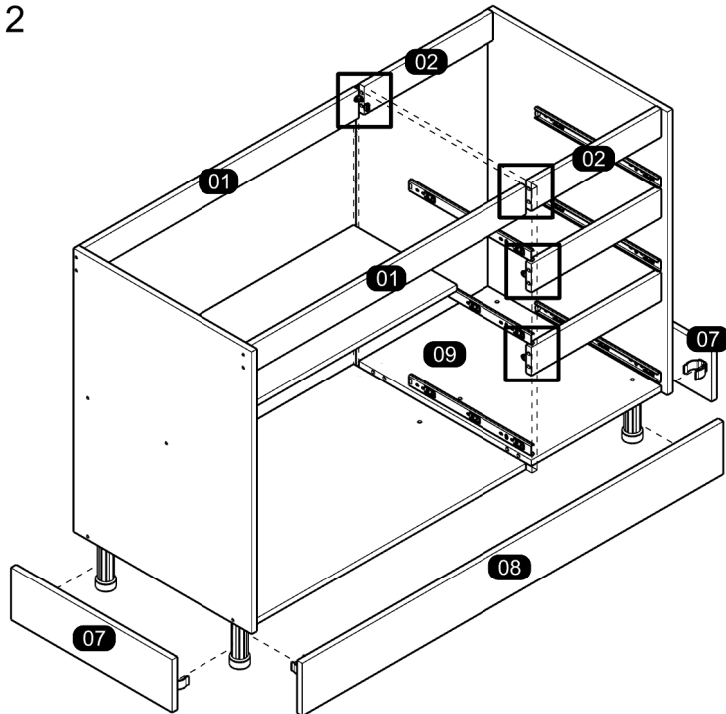

14

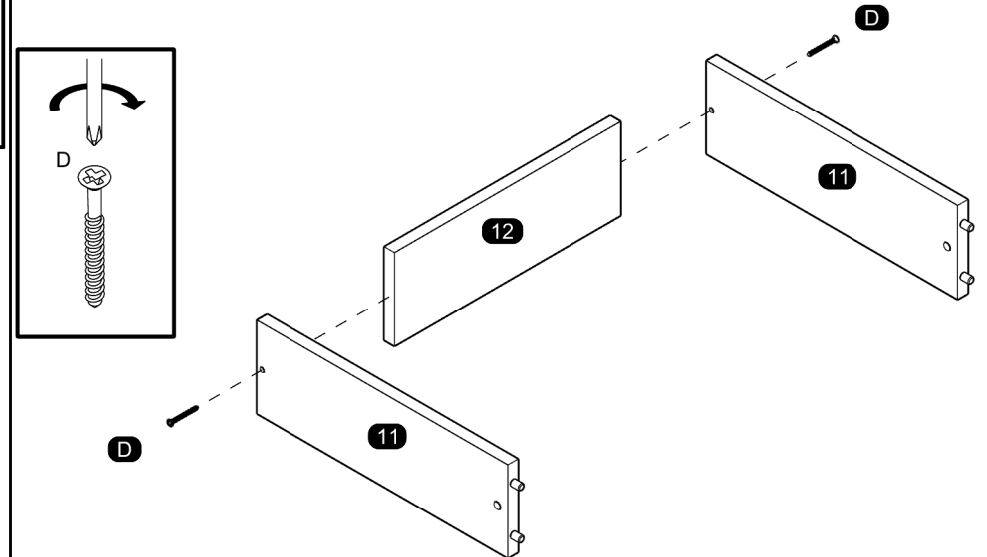

15

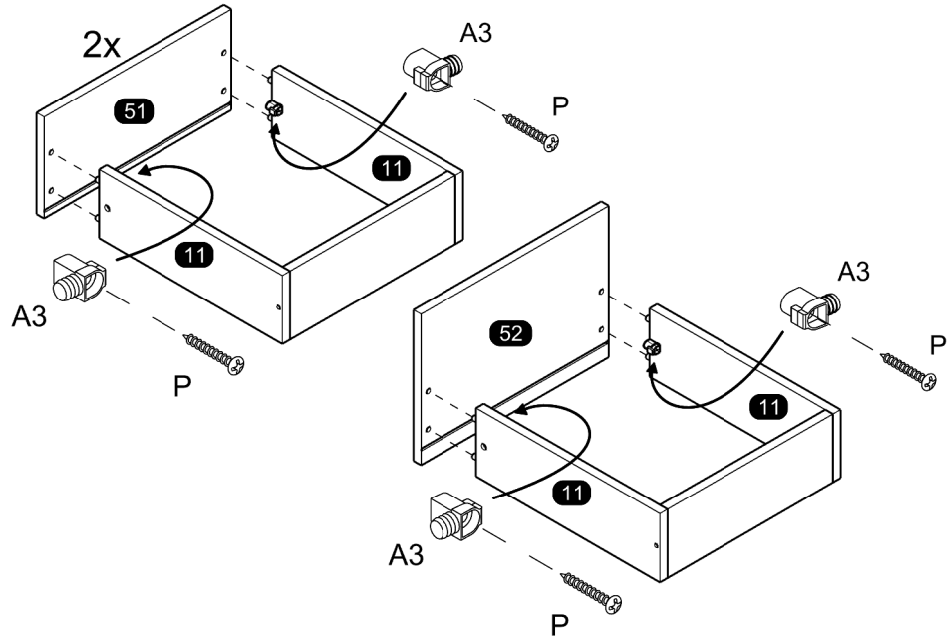

17

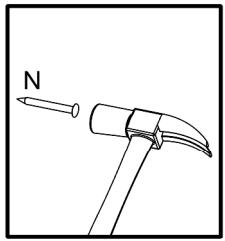
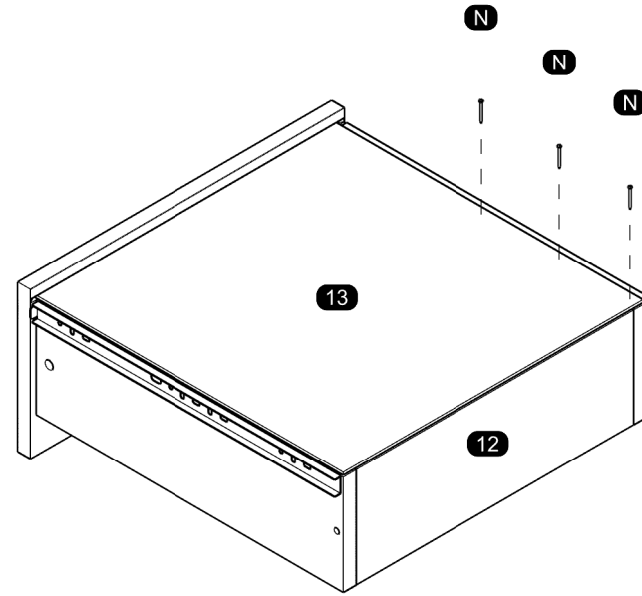

16

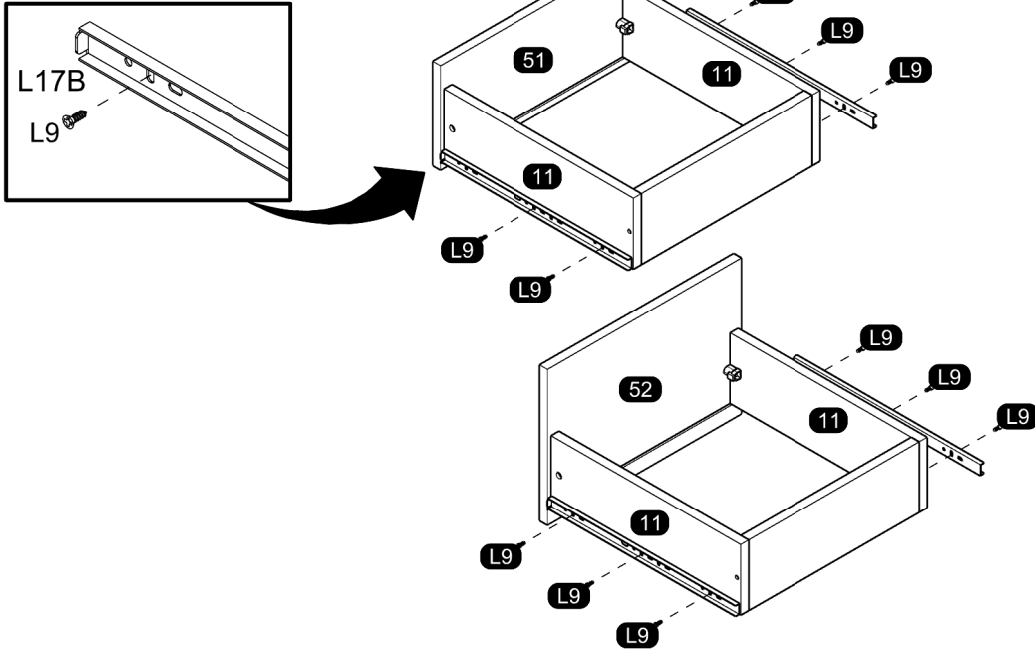

18

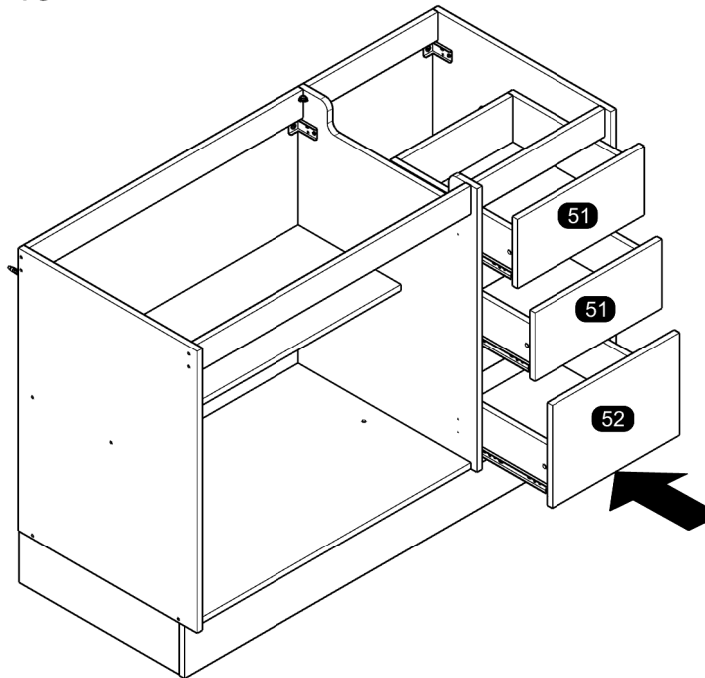

Drawer insertion  
 Inserção de gaveta  
 Inserción del cajón

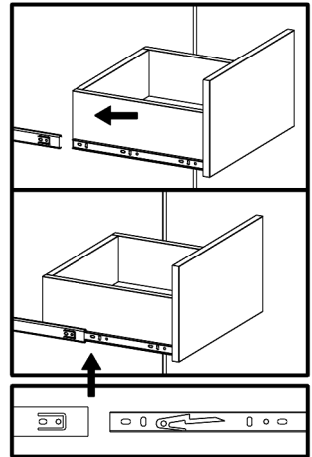

19

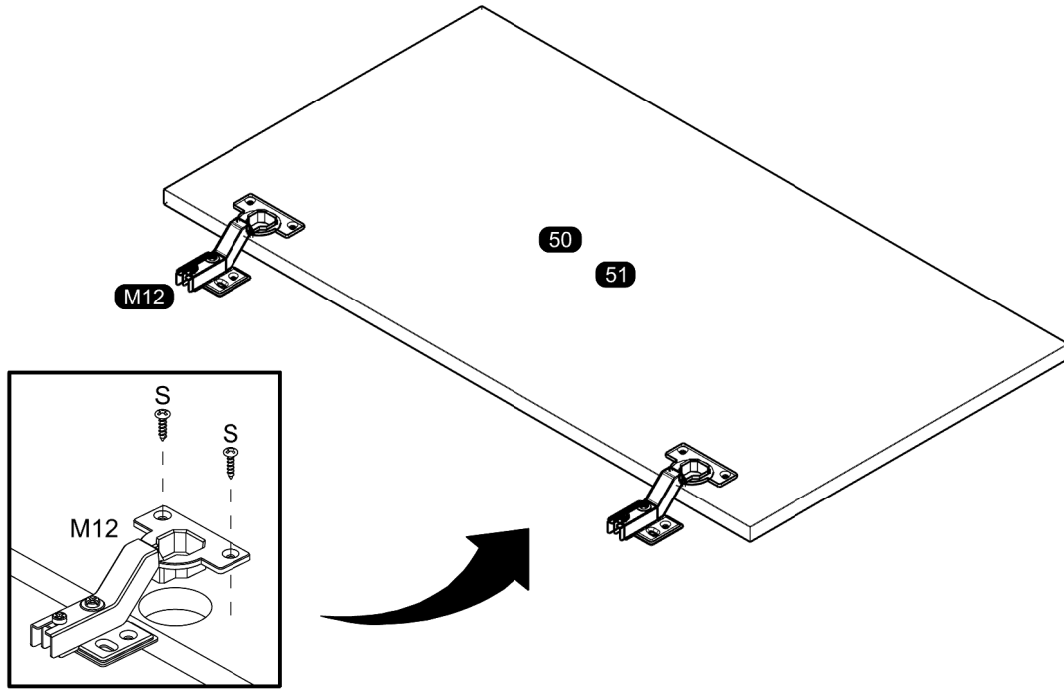

21

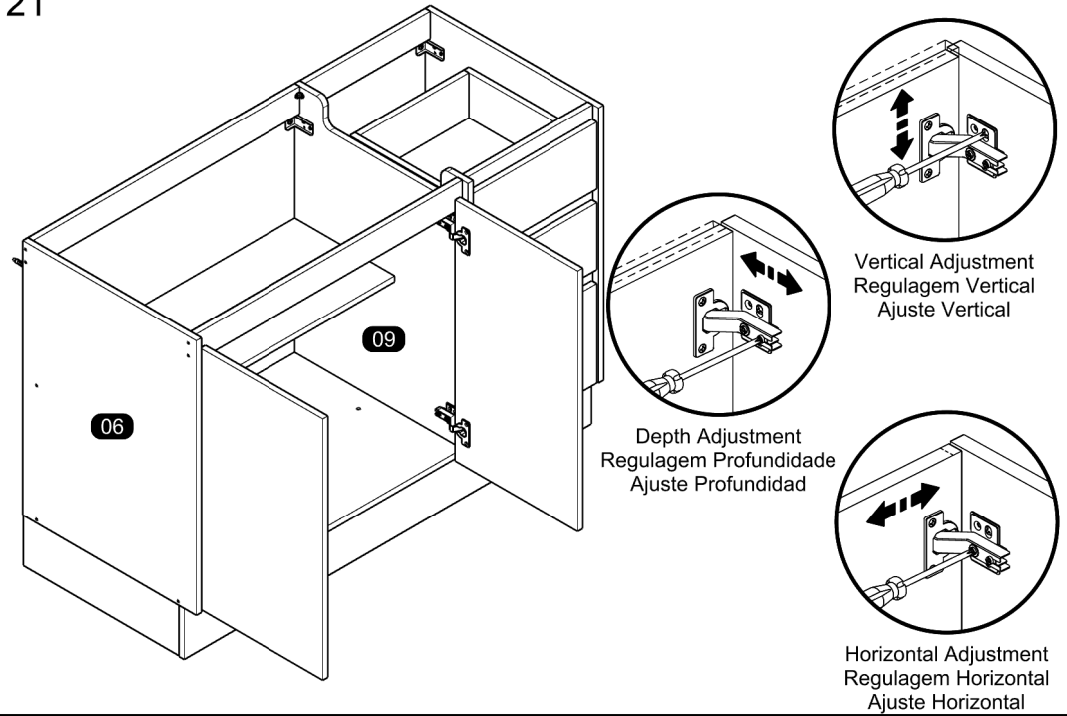

20

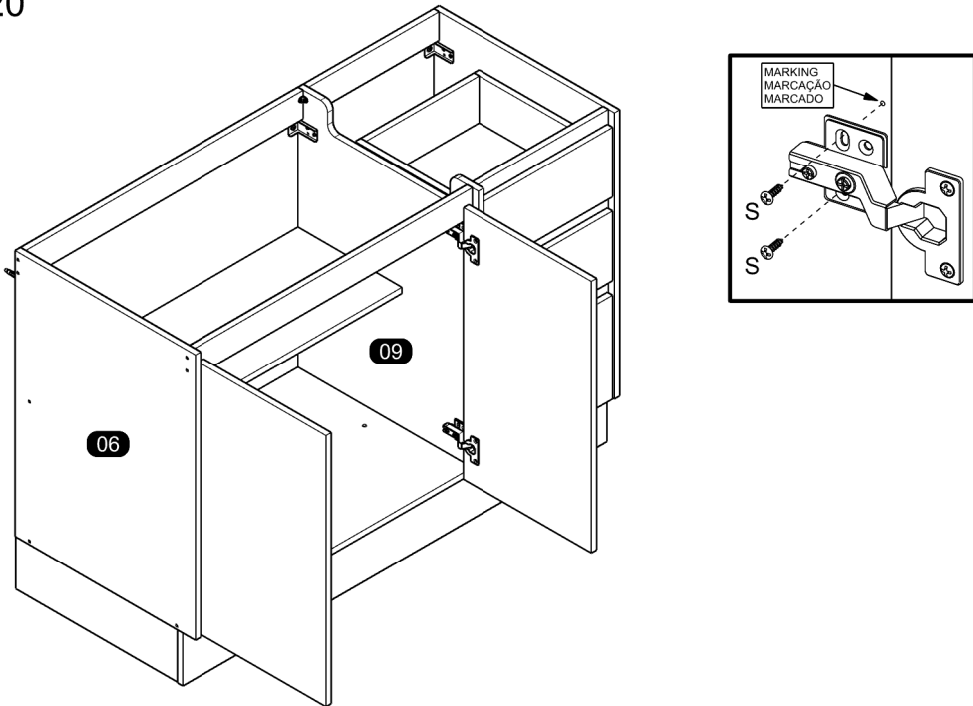

22

