

ASSEMBLY INSTRUCTIONS MANUAL DE MONTAGEM / INSTRUCCIONES DE ARMADO

WALL CABINET 1 FLAP DOOR / 2 SMALLER DOORS

ARMARIO AEREO 1PB / 2P MENOR

ARMARIO DE PARED 1 PUERTA HORIZONTAL / 2 PUERTAS PEQUEÑAS

Reference | Revise
Referência | Revisão
Referencia | Revisión

250485

00

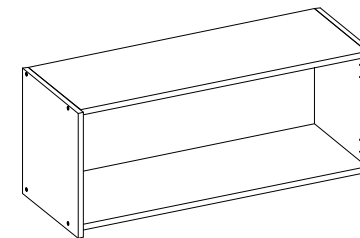

YOU WILL NEED VOCÊ VAI PRECISAR DE / USTED NECESITARÁ

Tools not supplied
Ferramentas não fornecidas / Herramientas no incluidas

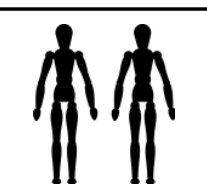

2 People
2 Pessoas
2 Personas

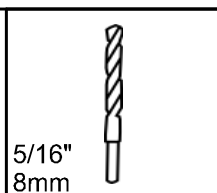

Drill bit
Broca
Taladro

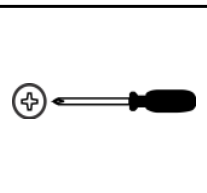

Screwdriver Phillips
Chave Phillips
Destornillador cruz

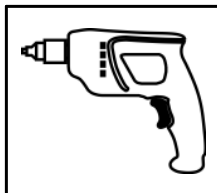

Drill machine
Furadeira
Taladro

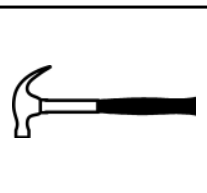

Hammer
Martelo
Martillo

MAXIMUM RECOMMENDED WEIGHT BEING THIS EVENLY DISTRIBUTED.
PESO MÁXIMO RECOMENDADO SENDO ESTE DISTRIBUÍDO UNIFORMEMENTE.
PESO MÁXIMO RECOMENDADO SIENDO ESTE UNIFORMEMENTE DISTRIBUIDO.

	LB	KG
E	17	8

PARTS IDENTIFICATION IDENTIFICAÇÃO DAS PEÇAS / IDENTIFICACIÓN DE LAS PIEZAS

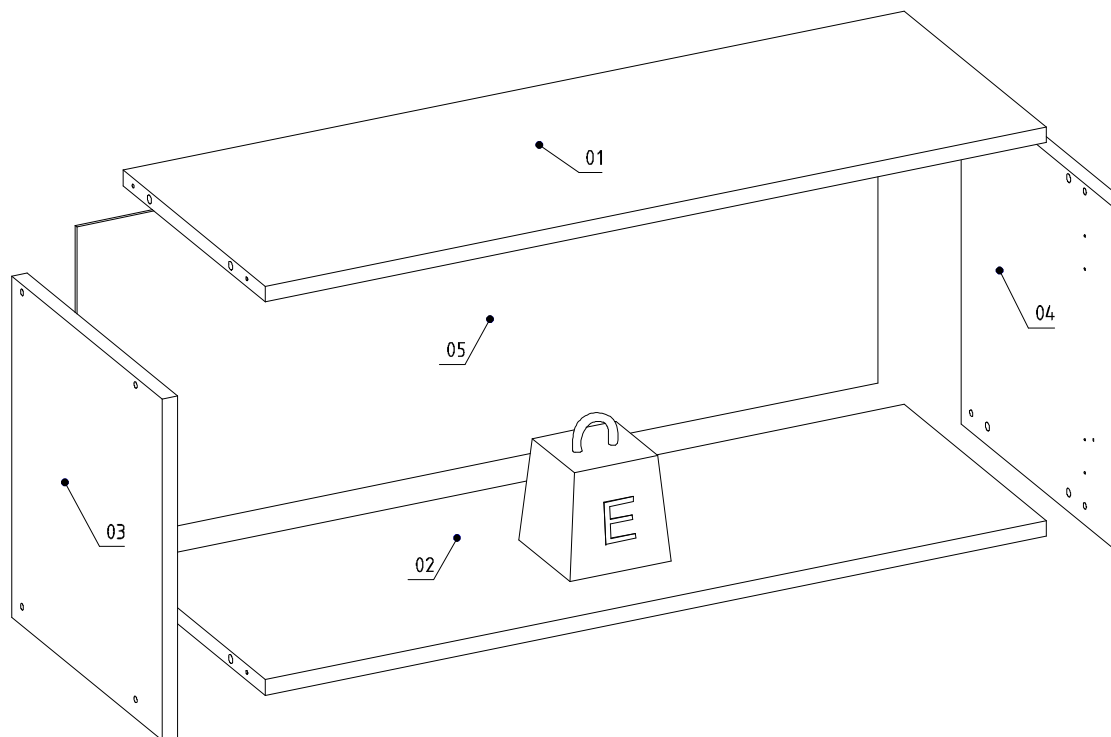

Nº	Measures_Inches	Medidas_cm	Qty./Qtd.
01	30 3/8 x 11 1/8 x 5/8	77.0 x 28.1 x 1.5	1
02	30 3/8 x 11 1/8 x 5/8	77.0 x 28.1 x 1.5	1
03	13 x 11 3/4 x 5/8	33.0 x 29.7 x 1.5	1
04	13 x 11 3/4 x 5/8	33.0 x 29.7 x 1.5	1
05	31 1/8 x 12 1/8 x 1/8	79.0 x 30.9 x 0.3	1

IDENTIFICATION OF ACCESSORIES IDENTIFICAÇÃO DOS ACESSÓRIOS/ IDENTIFICACIÓN DE ACCESORIOS



The separation of the accessories before you start the assembly will facilitate the same. In case of doubt on the size of the screws and bolts, use the ruler at the bottom of the page.
 A separação dos acessórios antes de iniciar a montagem facilitará a mesma. Em caso de dúvida no tamanho dos parafusos e cavilhas, utilize a régua ao final da página.
 La separación de los accesorios antes de comenzar el armado facilitará el mismo. En caso de duda sobre el tamaño de los tornillos y taquetes, utilice la regla al pie de página.

A		Flanged head screw Parafuso flangeado / Tornillo de cabeza flangeada	5,0x60 mm	2
B3		Bushing Bucha expansiva / Tapón	8x50 mm	2
E		Wooden dowel Cavilha / Taquete	8x30 mm	8
N		Nail Prego / Clavo	10x10	20
N5		Support "L" Soporte "L" / Soporte "L"	-	2
O		Flat head screw Parafuso chato / Tornillo de cabeza plana	4,5x45 mm	8
S		Pan head screw Parafuso panela / Tornillo de pan	3,5x14 mm	16
S7A		Gas piston Pistão a gás / Pistón de gas	-	1
S7B		Side support piston Suporte pistão lateral / Soporte pistón lateral	-	1
S7C		Door support piston Suporte pistão porta / Soporte pistón puerta	-	1
S7D		Pan head screw Parafuso panela / Tornillo de pan	3,5x12 mm	5
Z13		Metal hinge straight Dobradiça reta / Bisagra recta	35 mm	2



ATENÇÃO!

For hinged doors, the (M12) accessory and (S) fixing screws are supplied in the door package

Na configuração com portas de giro, o acessório (M12) e os demais parafusos de fixação (S) acompanham o produto no volume das portas

Para puertas batientes, el accesorio (M12) y los tornillos de fijación (S) se suministran en el bulto de las Puertas.

M12		Metal hinge super high Dobradiça super alta / Bisagra alta	35 mm	4
S		Pan head screw Parafuso panela / Tornillo de pan	3,5x14 mm	24



PRE-ASSEMBLE PRÉ-MONTAGEM / PRE ARMADO

01

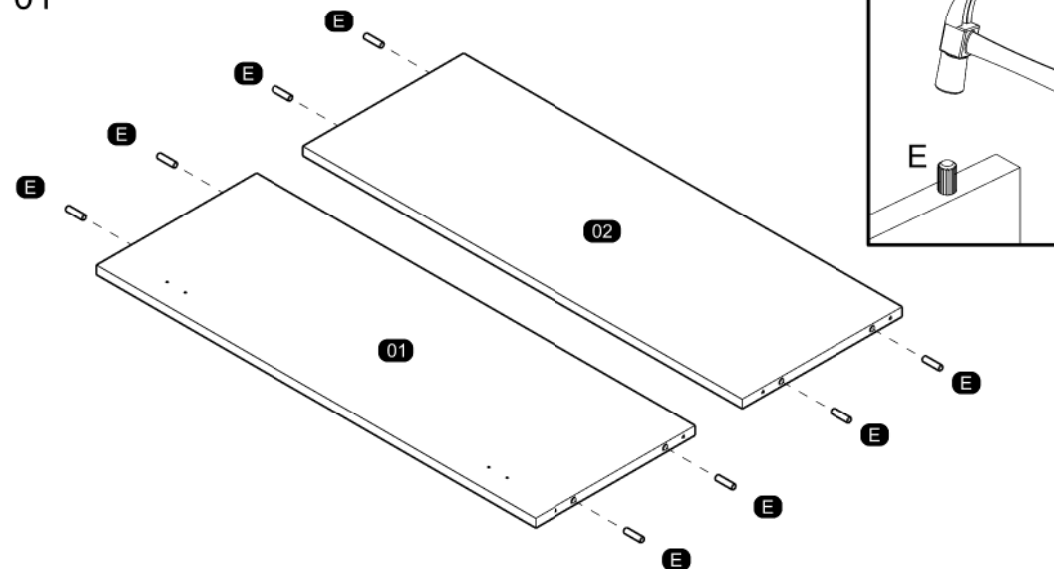

ASSEMBLY MONTAGEM / ARMADO

02

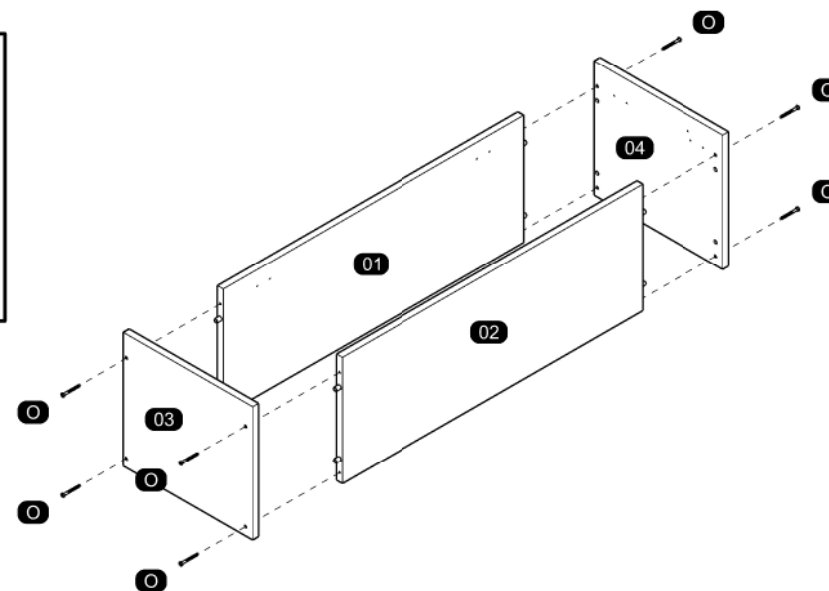
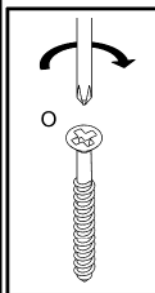

03

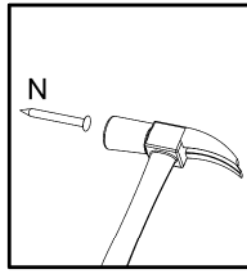
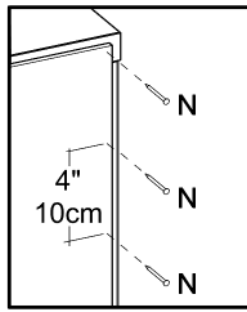
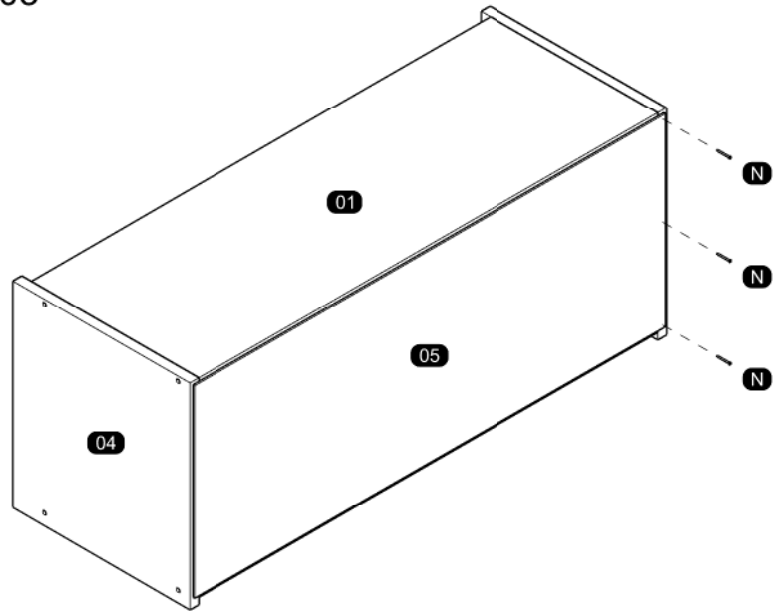

MOUNTING ON THE CHOSEN DOOR MODEL
MONTAGEM NO MODELO DE PORTA ESCOLHIDO / MONTAJE EN EL MODELO DE PUERTA ELEGIDO

05

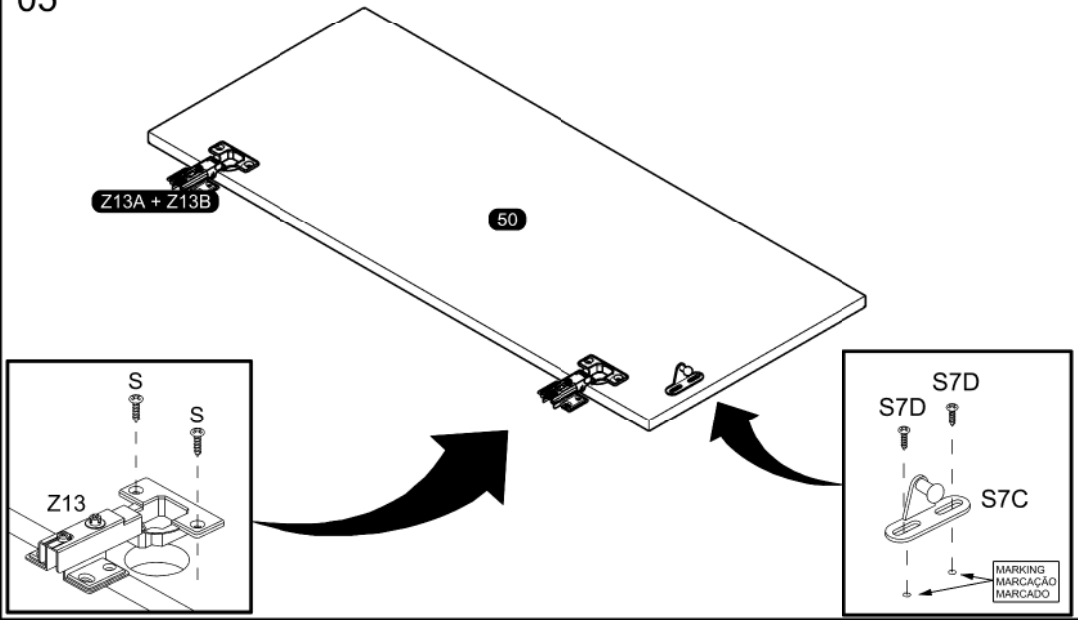

04

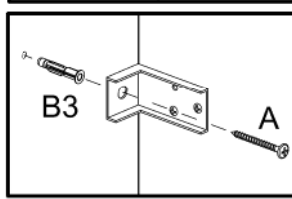
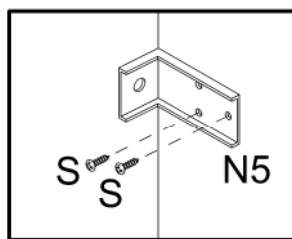
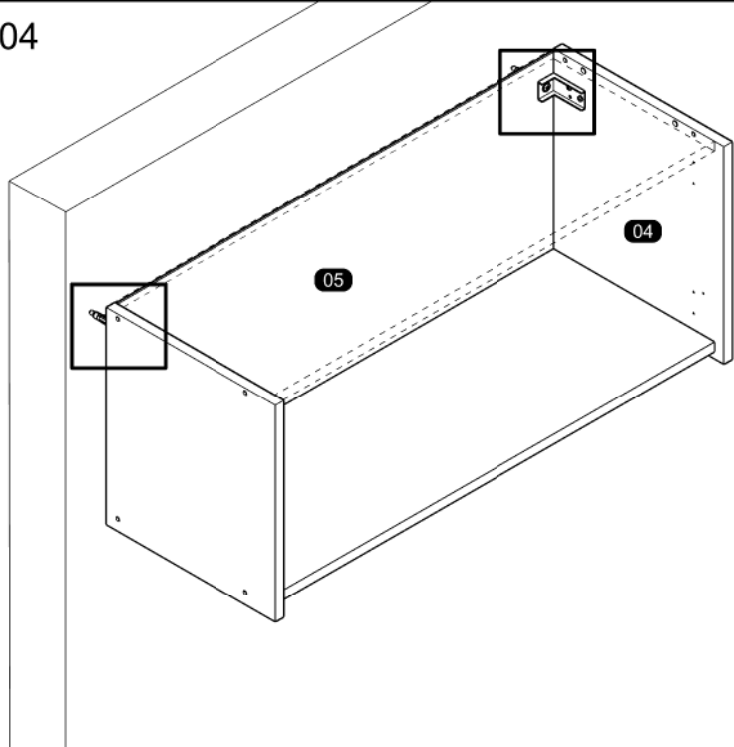

06

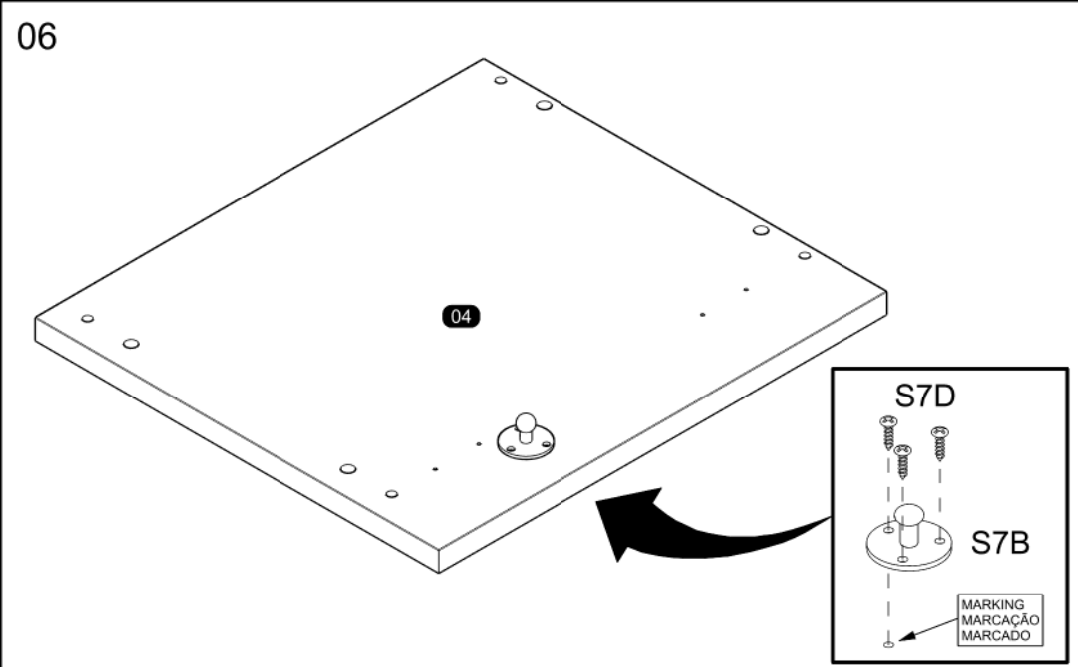

07

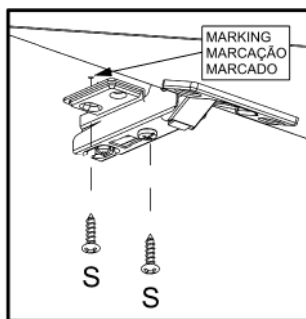
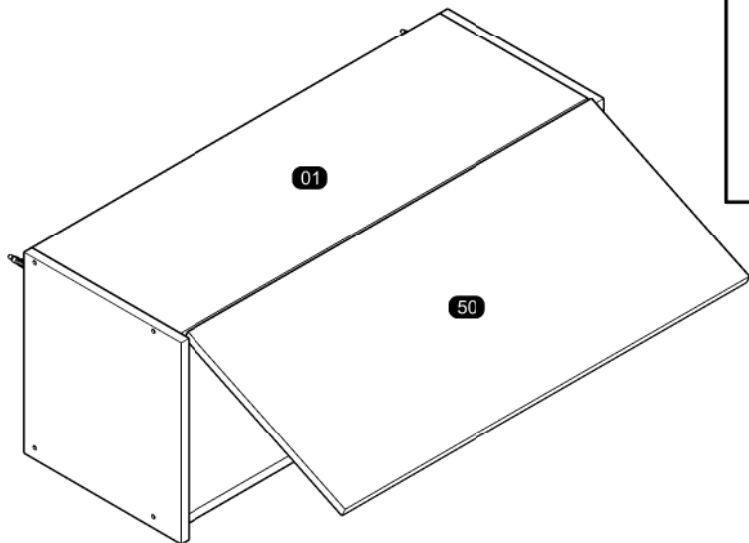

09

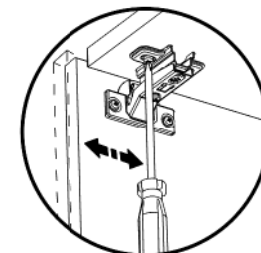
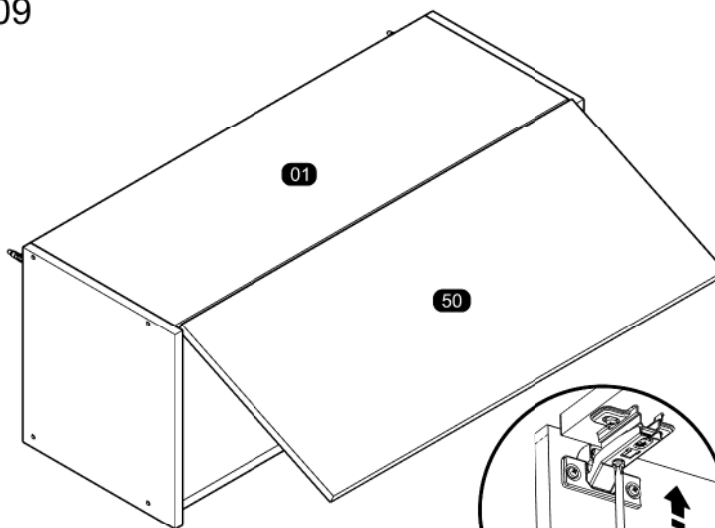

Horizontal Adjustment
Regulagem Horizontal
Ajuste Horizontal

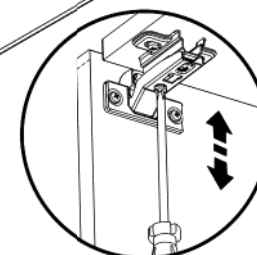

Vertical Adjustment
Regulagem Vertical
Ajuste Vertical

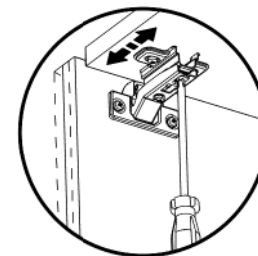

Depth Adjustment
Regulagem Profundidade
Ajuste Profundidade

08

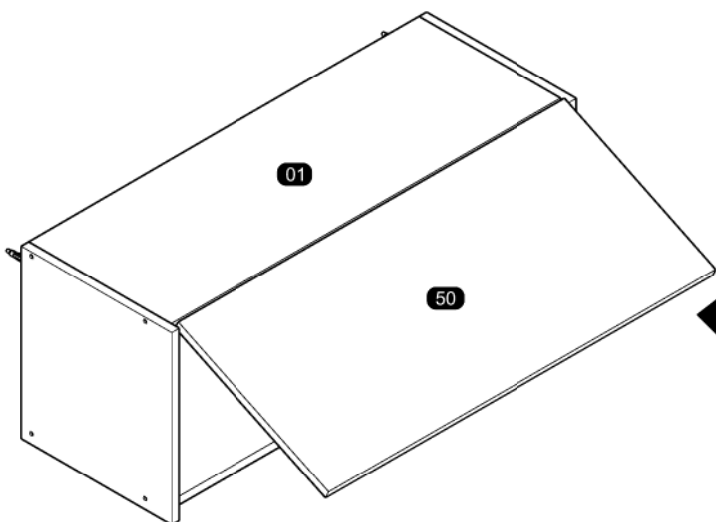

Follow the instruction corresponding to the template you received.
Siga a instrução correspondente ao modelo que recebeu.
Siga las instrucciones correspondientes al modelo que recibió.

Model 1 / Modelo 1

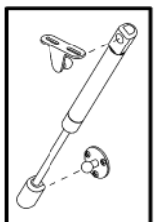

Model 2 / Modelo 2

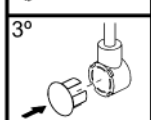
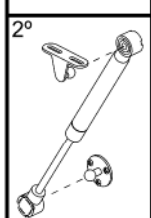
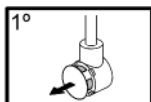

10

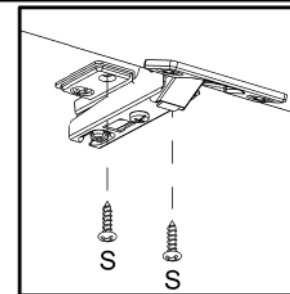
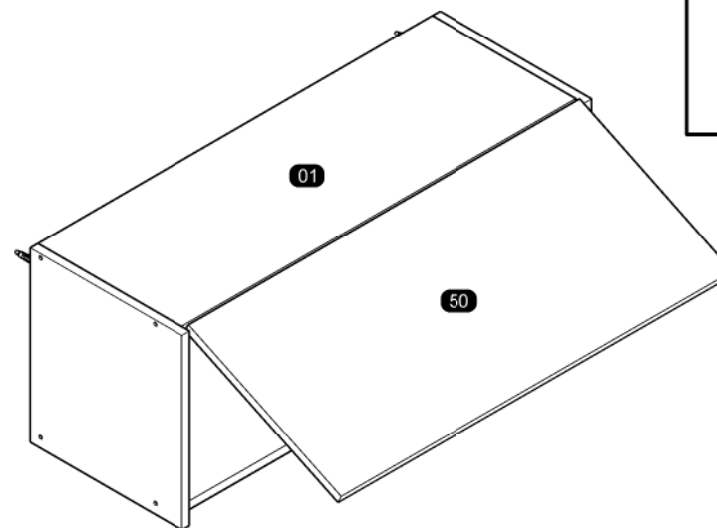

MOUNTING ON THE CHOSEN DOOR MODEL
 MONTAGEM NO MODELO DE PORTA ESCOLHIDO / MONTAJE EN EL MODELO DE PUERTA ELEGIDO

11

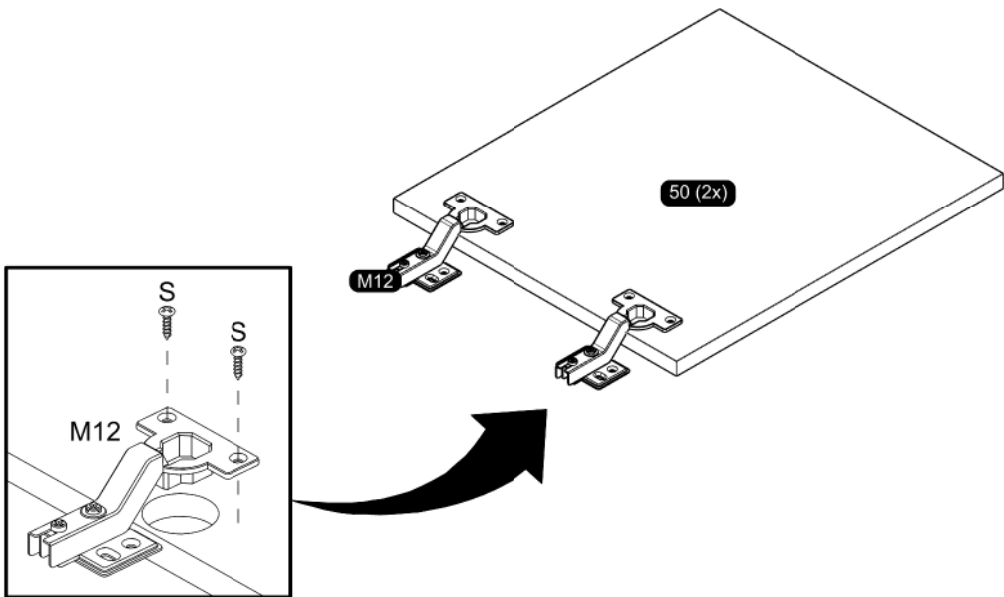

13

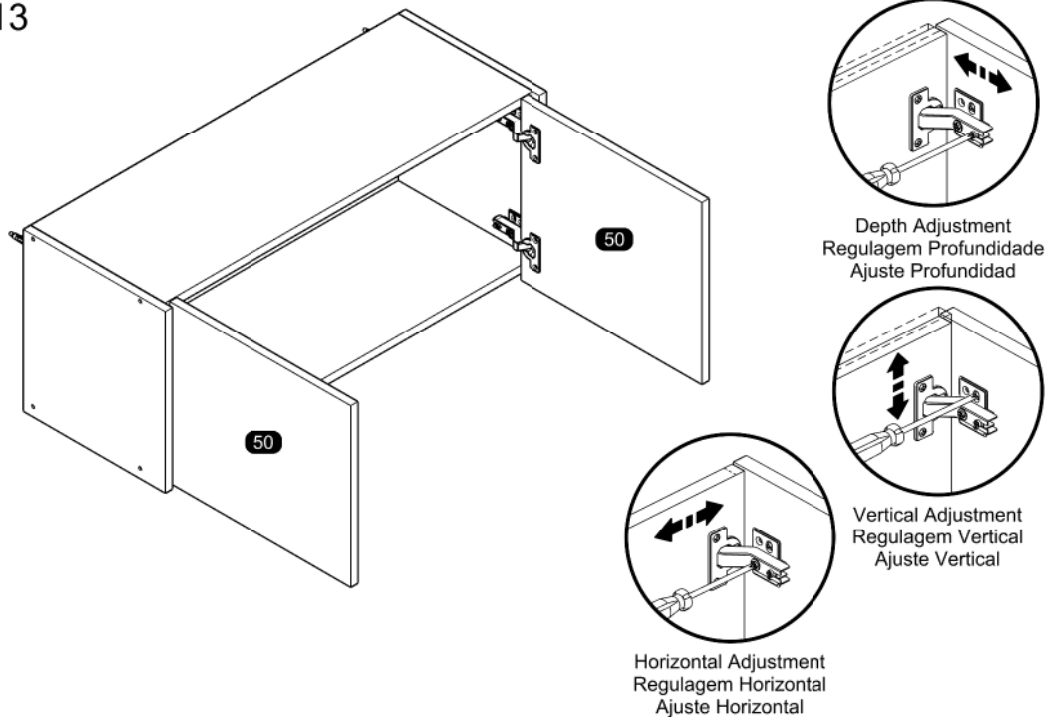

12

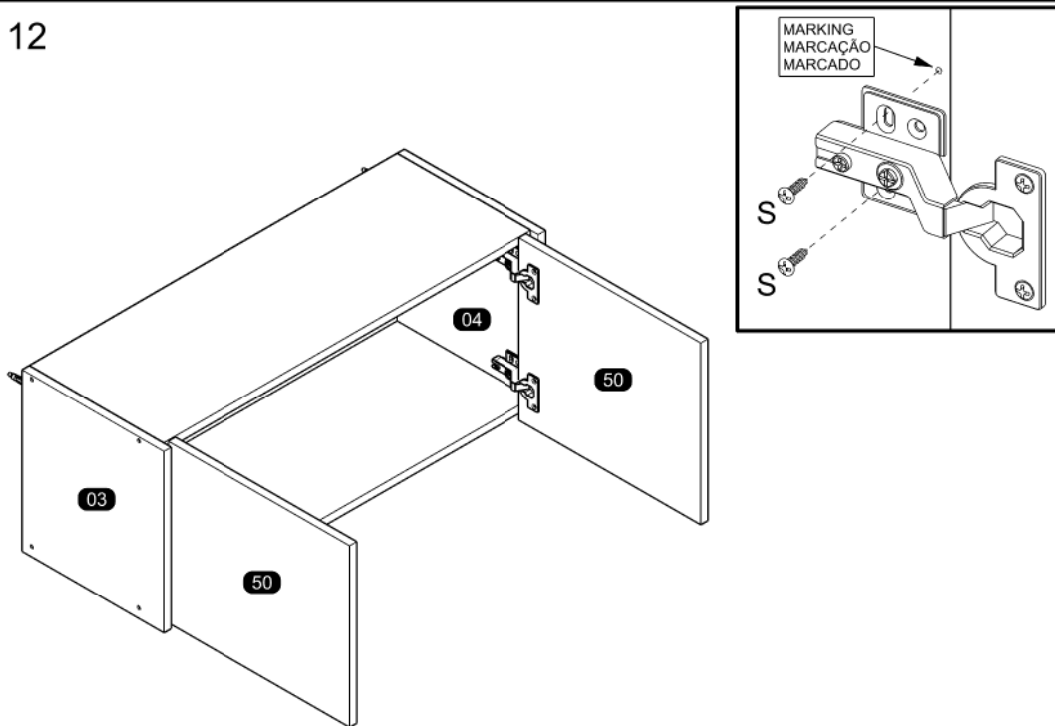

14

