

# ASSEMBLY INSTRUCTIONS MANUAL DE MONTAGEM / INSTRUCCIONES DE ARMADO

WALL CABINET 2 DOORS  
AEREO 2P  
ARMARIO DE PAREDE 2 PUERTAS

Reference  
Referência  
Referencia **260031** | Revise  
| Revisão  
| Revisión **00**

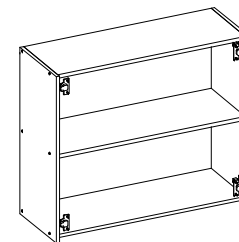

**YOU WILL NEED  
VOCÊ VAI PRECISAR DE / USTED NECESITARÁ**

Tools not supplied  
Ferramentas não fornecidas / Herramientas no incluidas

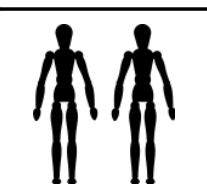

2 People  
2 Pessoas  
2 Personas

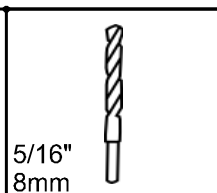

5/16"  
8mm

Drill bit  
Broca  
Taladro

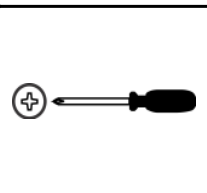

Screwdriver Phillips  
Chave Phillips  
Destornillador cruz

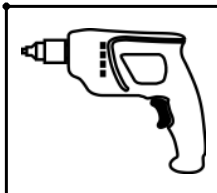

Drill machine  
Furadeira  
Taladro

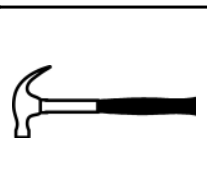

Hammer  
Martelo  
Martillo

**MAXIMUM RECOMMENDED WEIGHT  
BEING THIS EVENLY DISTRIBUTED.**  
**PESO MÁXIMO RECOMENDADO SENDO  
ESTE DISTRIBUÍDO UNIFORMEMENTE.**  
**PESO MÁXIMO RECOMENDADO SIENDO  
ESTE UNIFORMEMENTE DISTRIBUIDO.**

	LB	KG
F	22	10

**PARTS IDENTIFICATION  
IDENTIFICAÇÃO DAS PEÇAS / IDENTIFICACIÓN DE LAS PIEZAS**

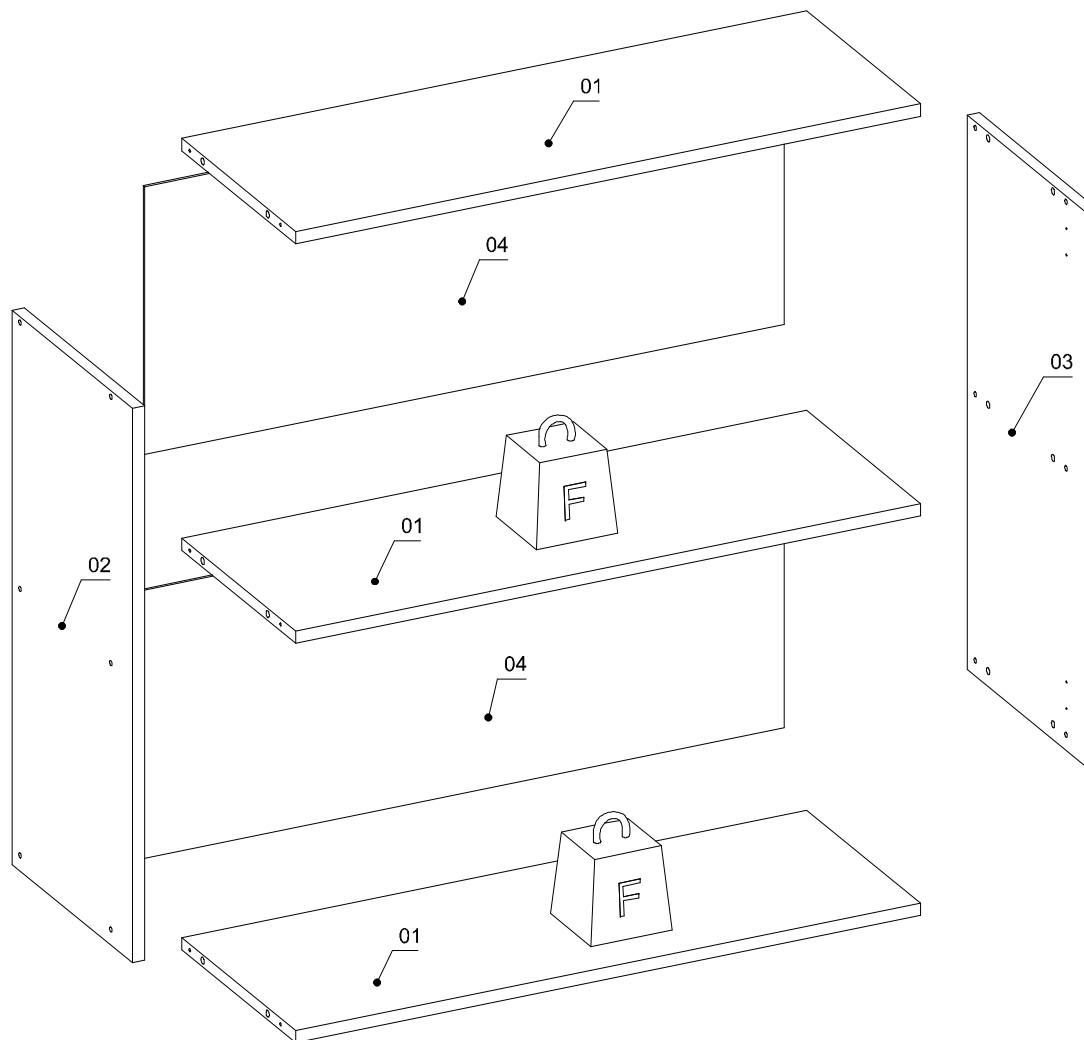

Nº	Measures_Inches	Medidas_cm	Qty./Qtd.
01	30 3/8 x 11 1/8 x 5/8	77.0 x 28.1 x 1.5	3
02	26 3/8 x 11 3/4 x 5/8	67.0 x 29.7 x 1.5	1
03	26 3/8 x 11 3/4 x 5/8	67.0 x 29.7 x 1.5	1
04	31 x 12 3/4 x 1/8	78.8 x 32.4 x 0.3	2

## IDENTIFICATION OF ACCESSORIES IDENTIFICAÇÃO DOS ACESSÓRIOS/ IDENTIFICACIÓN DE ACCESORIOS



The separation of the accessories before you start the assembly will facilitate the same. In case of doubt on the size of the screws and bolts, use the ruler to bottom of page.  
 A separação dos acessórios antes de iniciar a montagem facilitará a mesma. Em caso de dúvida no tamanho dos parafusos e cavilhas, utilize a régua ao final da página.  
 La separación de los accesorios antes de comenzar el armado facilitará el mismo. En caso de duda sobre el tamaño de los tornillos y taquetes, utilice la regla al pie de página.

A		Flanged head screw Parafuso flangeado / Tornillo de cabeza flangeada	5,0x60 mm	2
B3		Bushing Bucha expansiva / Tapón	8x50 mm	2
C1		Metal claw Garra de metal / Garra metal	-	5
E		Wooden dowel Cavilha / Taquete	8x30 mm	12
M12		Metal hinge super high Dobradiça super alta / Bisagra alta	35 mm	4
N		Nail Prego / Clavo	10x10	37
N5		Support "L" Soporte "L" / Soporte "L"	-	2
O		Flat head screw Parafuso chato / Tornillo de cabeza plana	4,5x45 mm	12
S		Pan head screw Parafuso panela / Tornillo de pan	3,5x14 mm	28



## PRE-ASSEMBLE PRÉ-MONTAGEM / PRE ARMADO

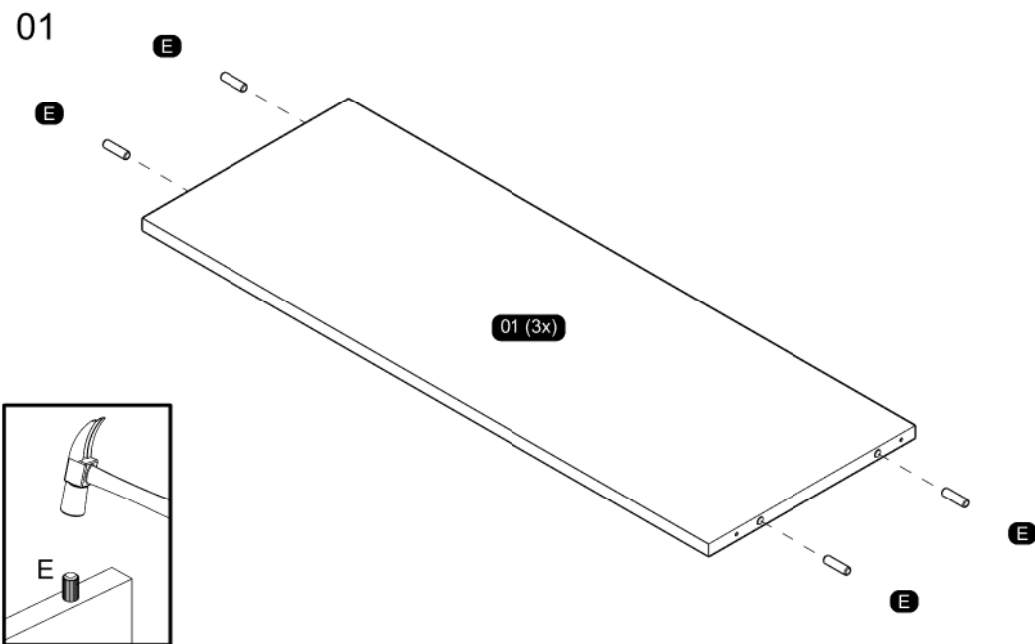

## PRE-ASSEMBLE PRÉ-MONTAGEM / PRE ARMADO

02

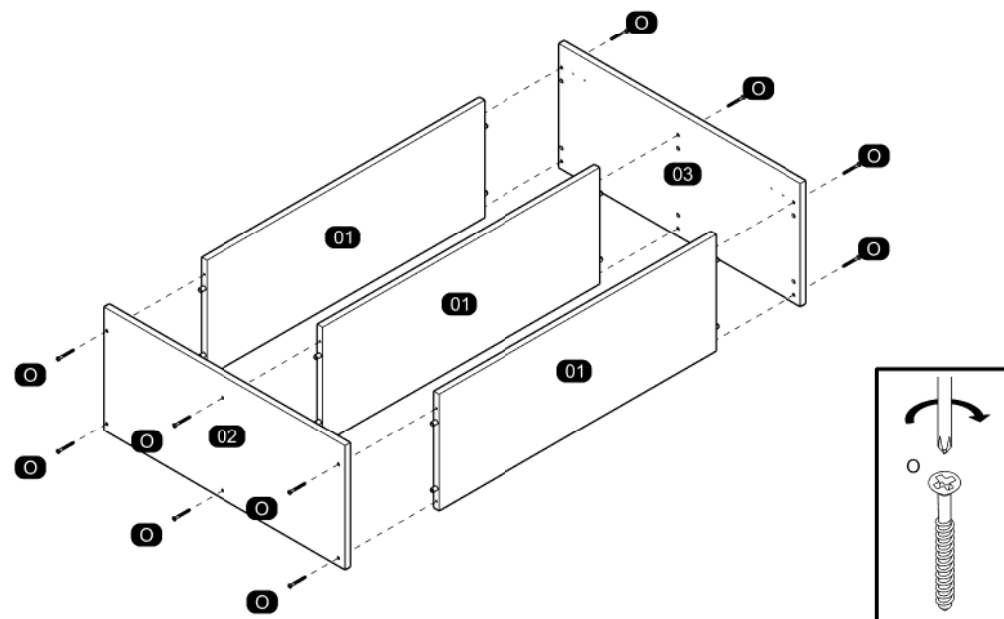

03

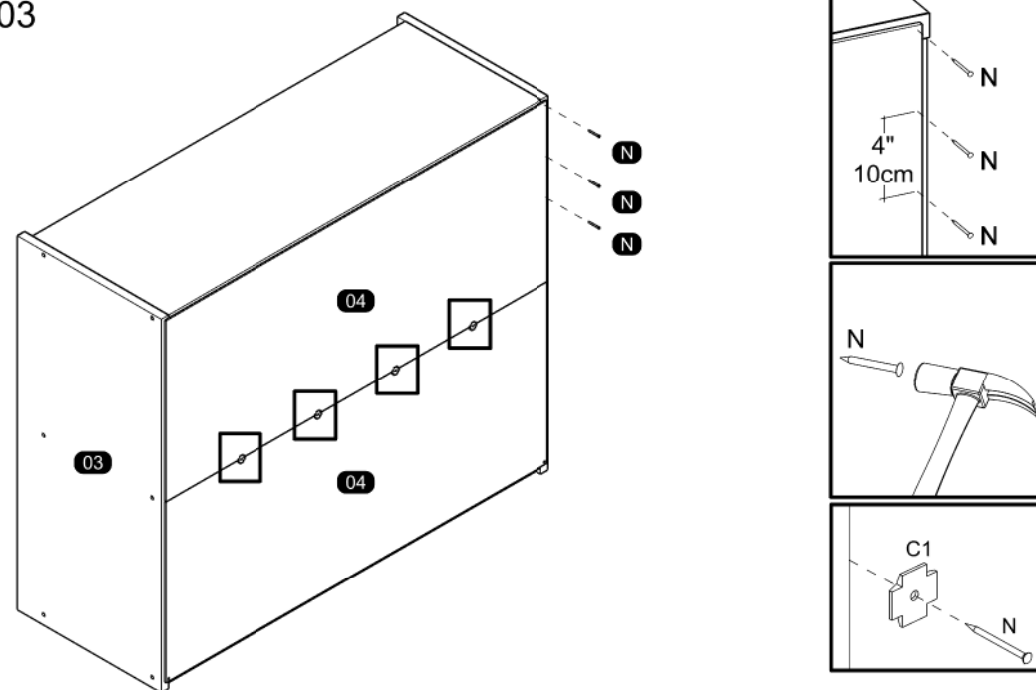

04

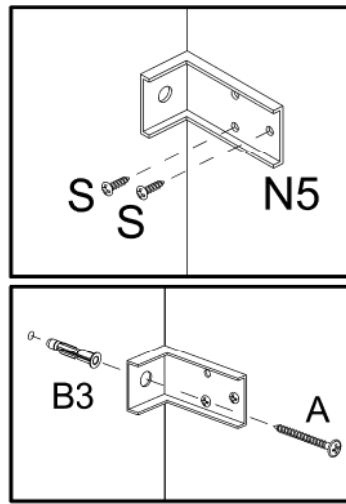
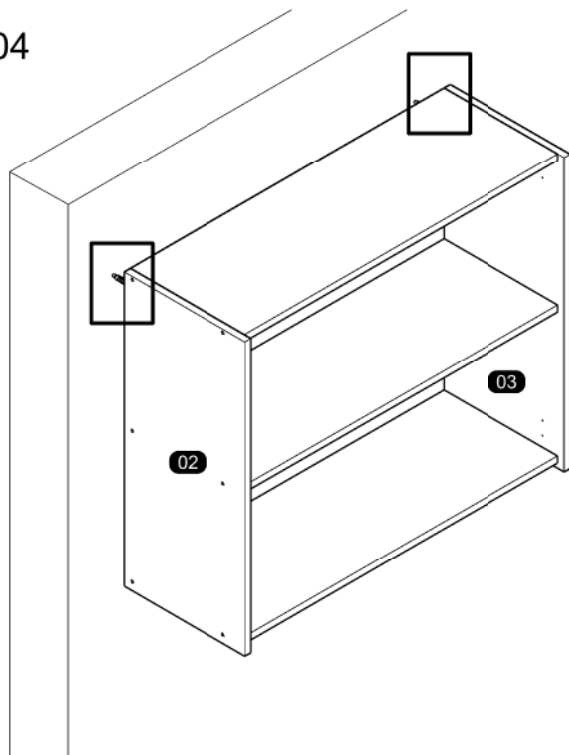

06

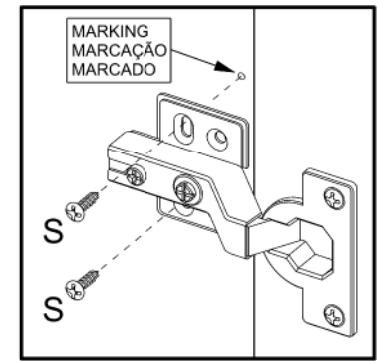
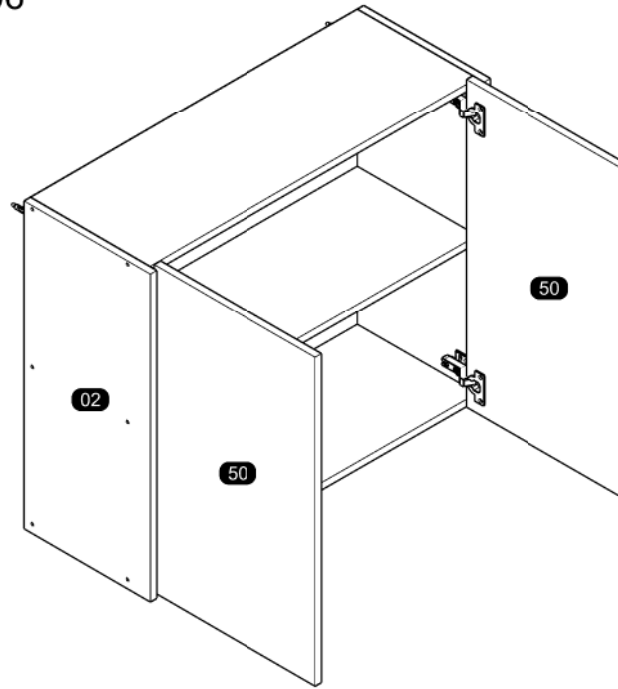

05

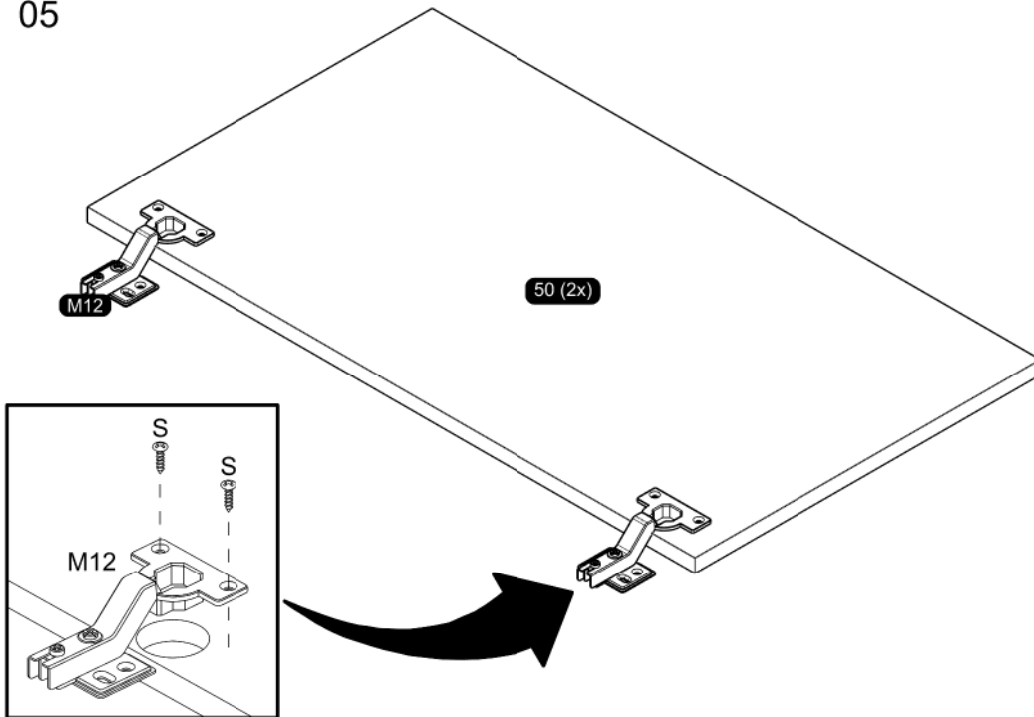

07

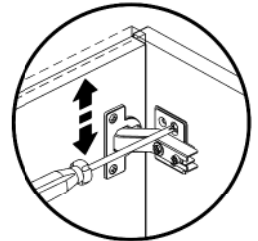
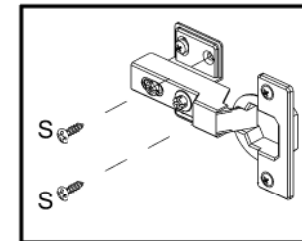
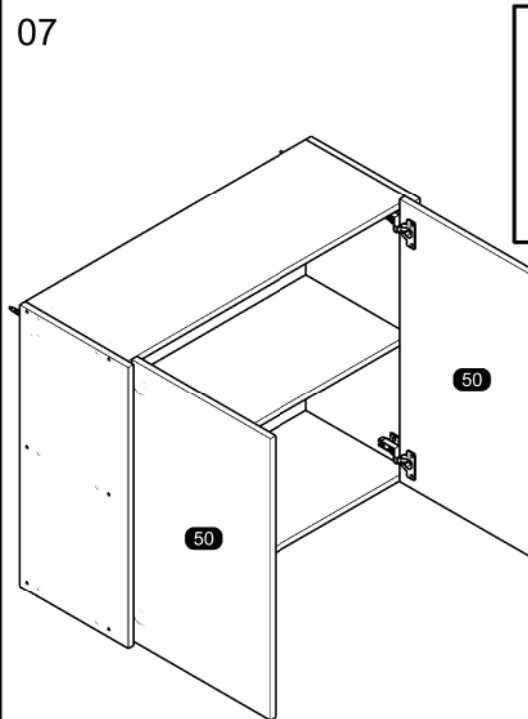

Vertical Adjustment  
Regulagem Vertical  
Ajuste Vertical

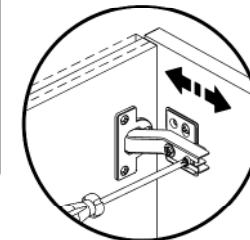

Depth Adjustment  
Regulagem Profundidade  
Ajuste Profundidade

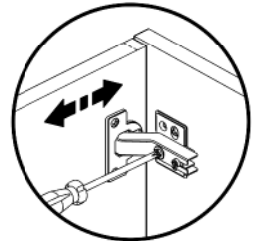

Horizontal Adjustment  
Regulagem Horizontal  
Ajuste Horizontal