

Escritaninha e Penteadeira Dora

Escritaninha e Penteadeira Dora /
Escritaninha e Penteadeira Dora /
Escritaninha e Penteadeira Dora

Versão 1.0 / Versión 1.0 / 1.0 Version

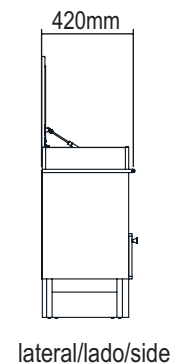
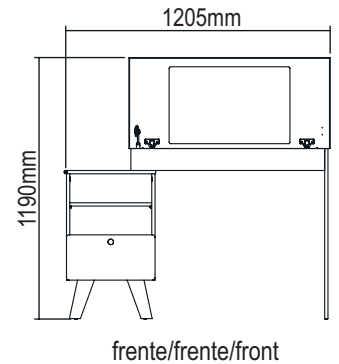
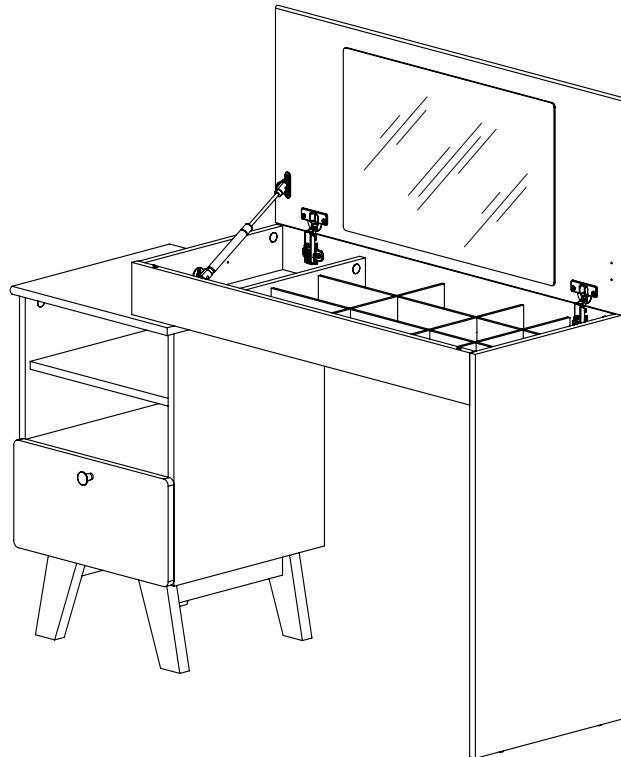
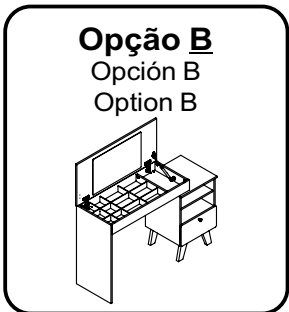
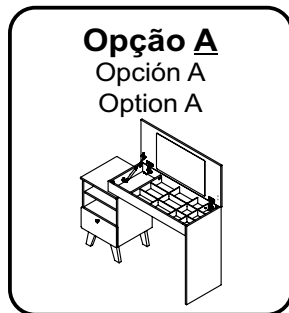

Conservação e Limpeza - Conservación y Limpieza - Conservation and Cleaning

Não expor o produto ao sol, altas temperaturas e umidade. Não arrastar objetos sobre a superfície do móvel (ex.: TV, DVD, aparelho de som, objetos decorativos...) e manter em local seco e arejado. Para a limpeza, utilizar um pano seco e macio. Não é necessário o uso de materiais abrasivos ou álcool.

No exponga el producto a la luz solar, las altas temperaturas y la humedad. No arrastre los objetos a través de la superficie de la unidad (por ejemplo, TV, DVD, equipo de música, objetos de decoración ...) Mantener en un lugar fresco y seco. Para la limpieza, utilizar un paño seco y suave. El uso de materiales abrasivos o del alcohol no es necesario.

Do not expose the product to sunlight, high temperatures and humidity. Do not drag objects across the surface of the unit (TV, DVD, stereo, decorative objects ...) keep it in a cool dry place. For cleaning, use a dry and soft cloth. Do not use abrasive materials or alcohol.

Garantia

Este certificado de Garantia é uma vantagem adicional oferecida ao consumidor, porém para que o mesmo tenha validade é imprescindível que seja apresentada a NOTA FISCAL de compra do produto.

Com este produto, a Artely tem como objetivo atender plenamente o proprietário-consumidor, proporcionando a garantia na forma aqui estabelecida, pelo período de 90 dias meses a partir da data da nota fiscal de compra. A Artely restringe a sua responsabilidade à substituição gratuita das peças defeituosas, em caso de defeitos ou avarias devidamente constatados como sendo de fabricação, durante a vigência desta garantia.

A Artely declara a garantia nula e sem efeito se o produto for alterado, adulterado, molhado ou consertado e ainda pela prática de montagem inadequada ou mau uso. Também será considerada nula em casos de força maior, como aqueles causados por agentes da Natureza (chuvas, incêndios, excesso de umidade, cupins,...) e eventos externos como objetos arrastados sobre a superfície do móvel (ex.: TV, DVD, aparelho de som, objetos decorativos...).

Para exercer seus direitos de comprador é importante que antes de montar seu produto você leia com atenção as instruções de cada passo do manual de montagem que acompanha o móvel.

Caso o produto não esteja em conformidade, entre em contato com a loja onde efetuou a compra e faça sua reclamação, apontando os defeitos técnicos observados. Para agilizar o seu atendimento, tenha sempre em mãos o manual de montagem com os respectivos números das peças defeituosas, conforme descritas no manual.

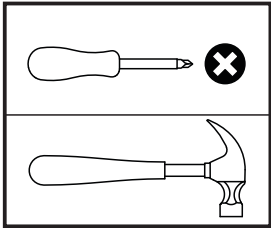

Ferramentas não fornecidas

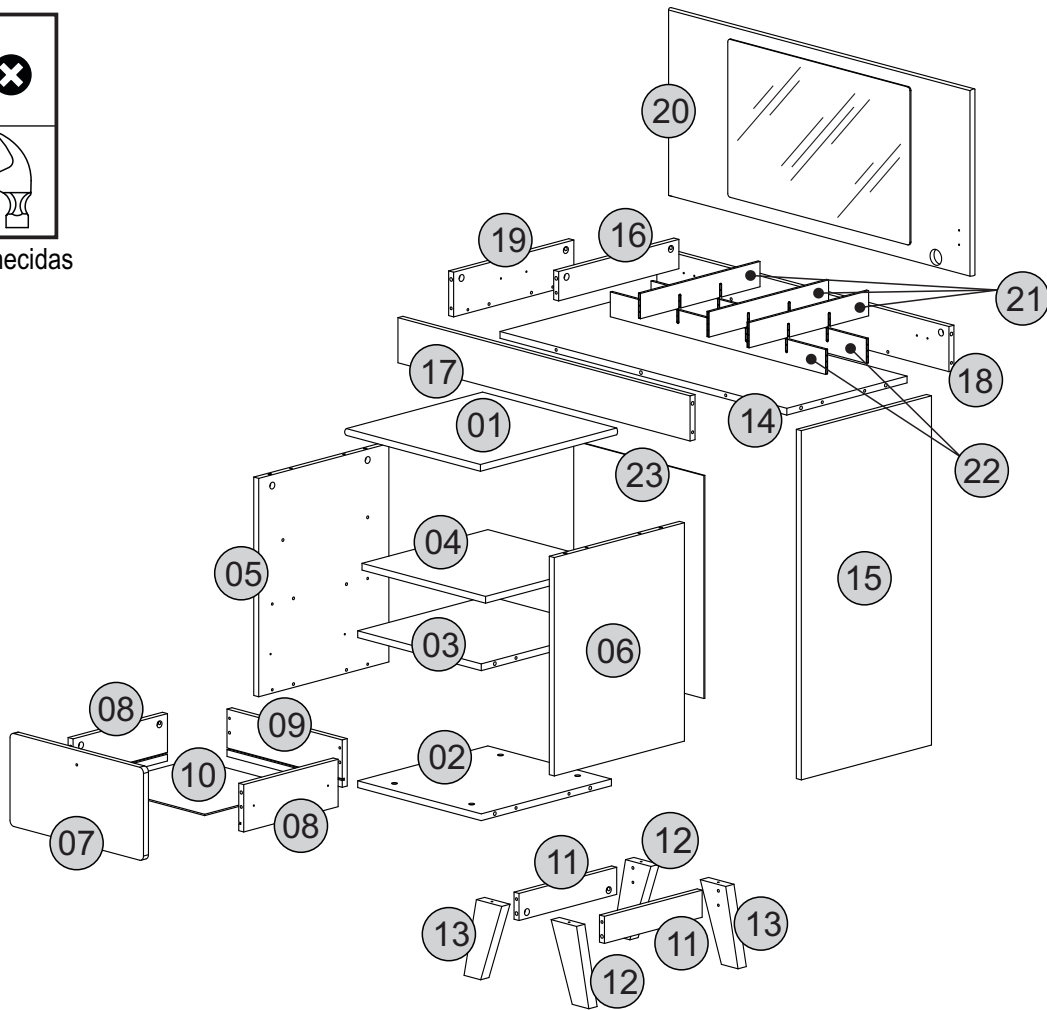











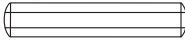

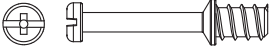
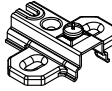

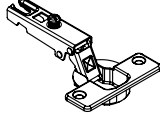
Descrição	Descripción	Description	Qty
1-Tampo (405x415x15mm)	1-Base	1-Base	1
2-Base (373x393x15mm)	2-Tapa	2-Top	1
3-Prateleira nicho (373x393x15mm)	3-Anaquele Fijo	3-Fixed Shelf	1
4-Prateleira móvel (373x380x15mm)	4-Anaquele Móvil	4-Mobile Shelf	1
5-Lateral esquerda (484x393x15mm)	5-Lado izquierdo	6-Left side	1
6-Lateral direita (484x383x15mm)	6-Lado direito	7-Right side	1
7-Frente gaveta (403x206x15mm)	7-Cajón Delantero	7-Front Drawer	1
8-Lateral gaveta (285x105x15mm)	8-Lado del cajón	8-Drawer Side	2
9-Traseiro gaveta (348x105x15mm)	9-Cajón trasero	9-Rear Drawer	1
10-Fundo gaveta (328x295x3mm)	10-Fondo del Cajón	10-Drawer Background	1
11-Travessa pé (459x295x3mm)	11-Plato de pie	11-Foot plater	2
12-Pé direito (175x77x25mm)	12-Pies Derecha	12-Right foot	2
13-Pé esquerdo (175x77x25mm)	13-Pies Izquierdo	13-Left foot	2
14-Tampo maior (866x363x15mm)	14-Tampo Grande	14-Bigger Top	1
15-Lateral maior (774x363x15mm)	15-Lado Grande	15-Bigger side	1
16-Travessa (363x65x15mm)	16-Plato	16-Plater	1
17-Travessa frontal (882x100x15mm)	17-Plato frontal	17-Front plater	1
18-Travessa traseira (882x100x15mm)	18-Plato trasero	18-Back plater	1
19-Travessa lateral (363x99x15mm)	19-Plato lateral	19-Side plater	1
20-Porta (913x411x15mm)	20-Puerta	20-Door	1
21-Divisória pequena (361x56x6mm)	21-División pequeña	21-Small division	3
22-Divisória grande (650x56x6mm)	22-División grande	22-Bigger division	2
23-Traseiro (494x393x3mm)	23-Fondo	23-Rear	1

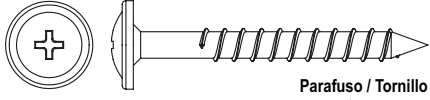

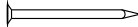
- O número na borda da peça corresponde ao manual.
 - Para retirada do número usar Lustra-Móveis, Alcool em Gel ou Borracha.
 - El número en el borde de la pieza coincide con el manual.
 - Use una goma de borrar blanca, alcohol en gel o lustrador para muebles para eliminar los números.
 - The number on the edge of the piece matches the manual.
 - Use a White eraser, Alcohol Gel or Furniture Polish to remove the numbers.

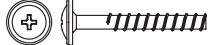
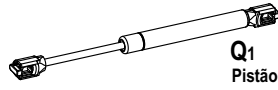
Lista de Materiais

Lista de Materiales/ Hardware List

A		Cavilha / Tarugo / Dowel Ø6x30mm	34	J		Puxador Tirador / Handle	01
B		Minifix / Minifix / Minifix Ø7x30mm	32	K		Dobradiça alta Bisagra alta High hinge	02
C		Tambor / Tambor / Minifix Cam Ø15x12mm	32	L		Dobradiça alta Bisagra alta High hinge	02
D		Tapa furo adesivo / Adhesivo / Hole Cover Ø18mm	18	M		Pino / Alfiler / Pin	04
E		Parafuso / Tornillo / Screw Ø5,0x40mm CF	04	N		Sapata Fixa / Pata Fija / Fixed Foot Ø2,0x10mm Plástico	06
F		Parafuso / Tornillo / Screw / Ø3,5x40mm CP	04	O		Prego / Clavo / Nail 8x8	14
G		Parafuso Tornillo / Screw Ø4x14mm CP	16	P		Corrediça Telescópica Guia Telescópica / Telescopic Slider 300mm	02
H		Parafuso / Tornillo / Screw Ø3,5x25mm CF	01	Q		Kit pistão gás Q1 Pistão gás inverso 60N	01
I		Batente Silicone / Silicona / Silicone 8mm - Silicone	02	Q2		Q2 Pino Lateral	01
				Q3		Q3 Pino Porta	
				Q4		Q4 Parafuso 3,5x14mm CC	

DICAS PARA FIXAR MINIFIX

TIP TO FASTEN THE MINIFIX
PISTA PARA ARREGLAR EL MINIFIX

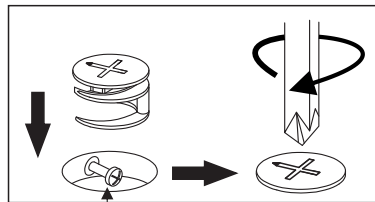

Cabeça do parafuso precisa estar no centro
La cabeza del tornillo debe estar en el centro
Screw head has to be in the center

Parafuso Minifix
Tornillo minifix/Minifix screw

Fixe o parafuso até o ressalto encostar na superfície da peça (veja o exemplo abaixo).

Tighten the screw until its overhang part lean on the piece surface (see the example below).

Fije el tornillo hasta que su parte sobresaliente toque la superficie de la pieza (vea el ejemplo abajo).

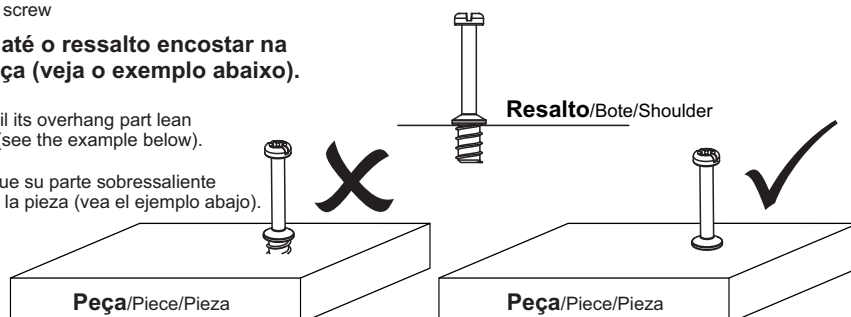

Passo 1

Paso/Step

PEÇA
Piece/Pieza

1 - TAMPO x1

FERRAGEM
Hardware/Herraje

B  04

FERRAMENTA
Tool/Herramienta

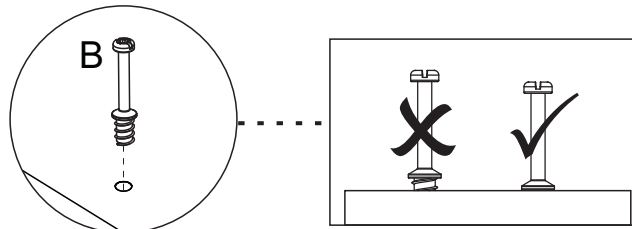
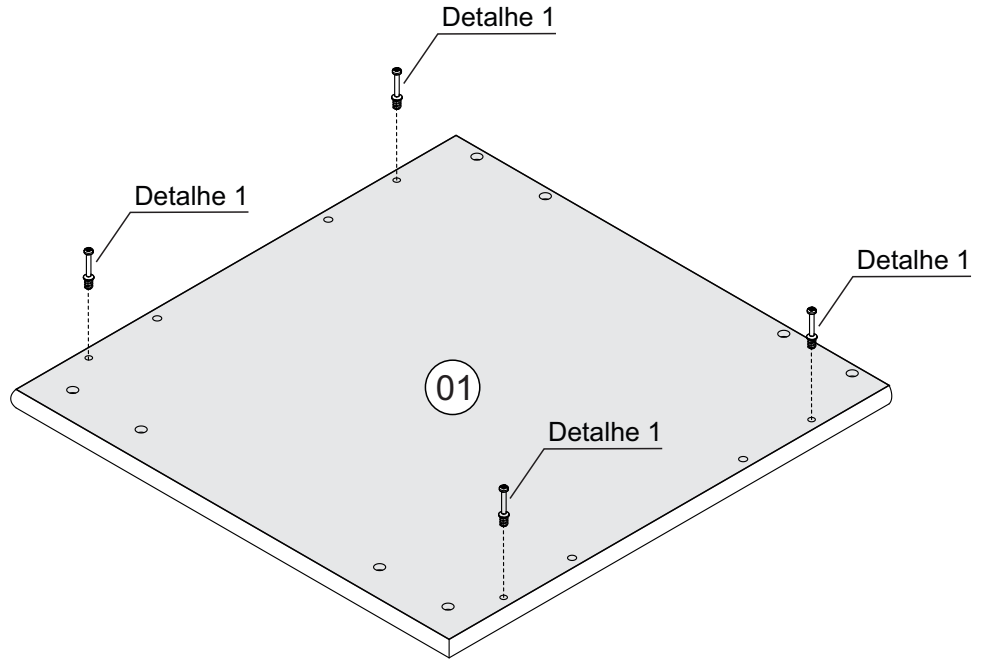
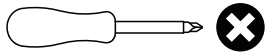

Detalhe 1
Detail/Detalle

Passo 2

Paso/Step

PEÇA
Piece/Pieza

2 - BASE x1

FERRAGEM
Hardware/Herraje

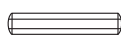
A  04

FERRAMENTA
Tool/Herramienta

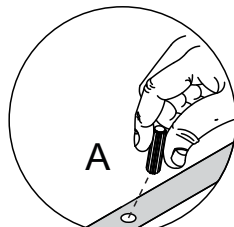
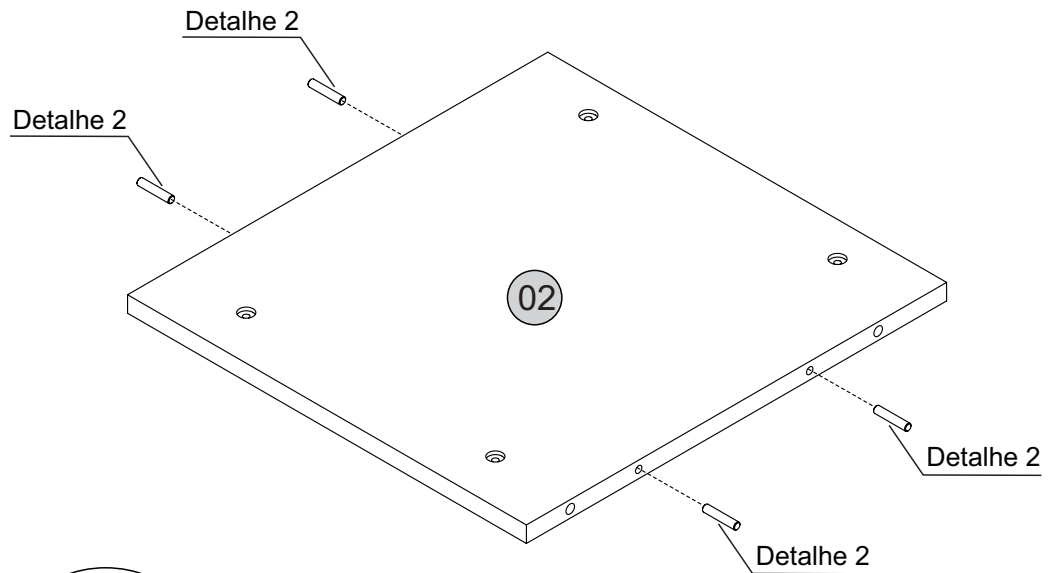
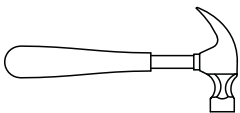

Detalhe 2
Detail/Detalle

Passo 5

Paso/Step

PEÇA
Piece/Pieza

6 - LATERAL DIREITA x1

FERRAGEM
Hardware/Herraje

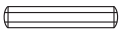
A  02

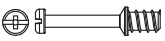
B  04

G  02

M  02

P  01

FERRAMENTA
Tool/Herramienta

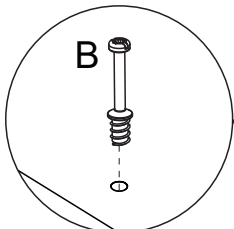
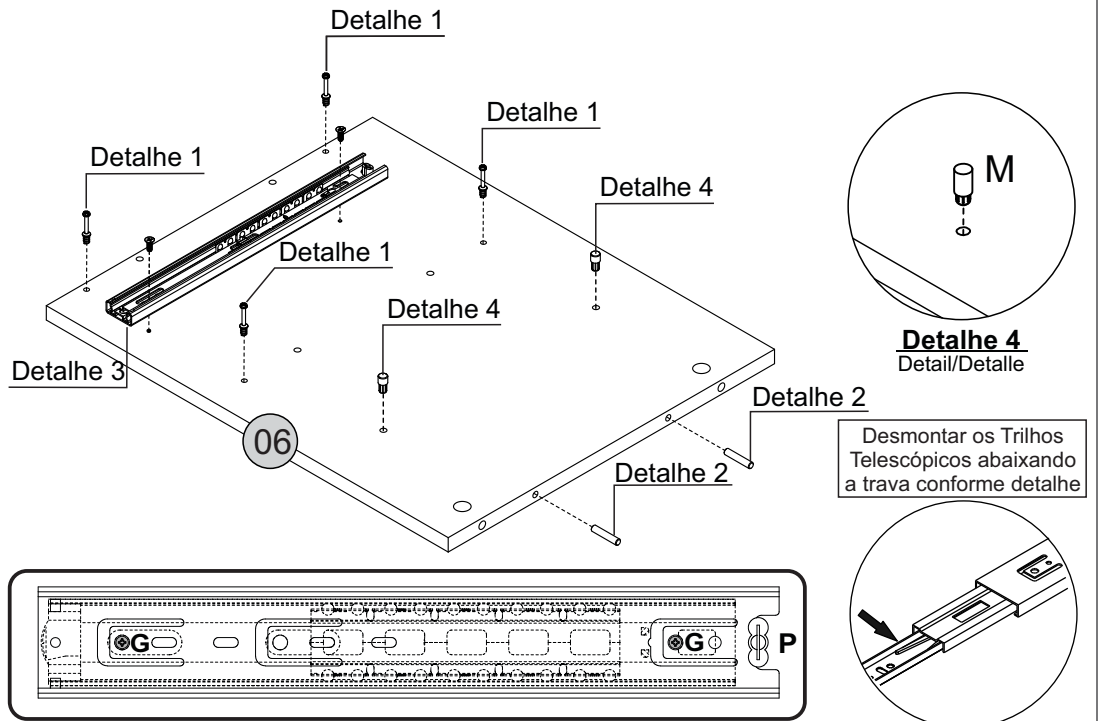
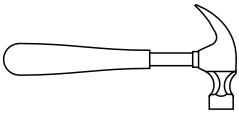
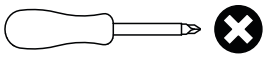

Detalhe 1
Detail/Detalle

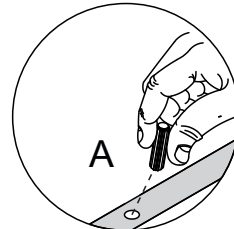
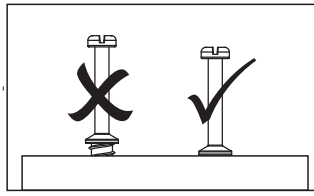

Detalhe 2
Detail/Detalle

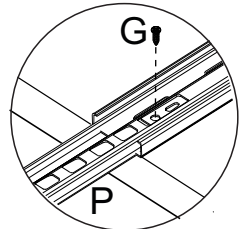

Detalhe 3
Detail/Detalle

Passo 6

Paso/Step

PEÇA
Piece/Pieza

07 - Frente Gaveta x1

08 - Lateral Gaveta x2

09 - Traseiro Gaveta x1

FERRAGEM
Hardware/Herraje

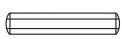
A  04

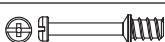
B  04

FERRAMENTA
Tool/Herramienta

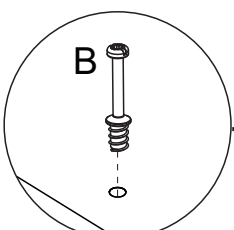
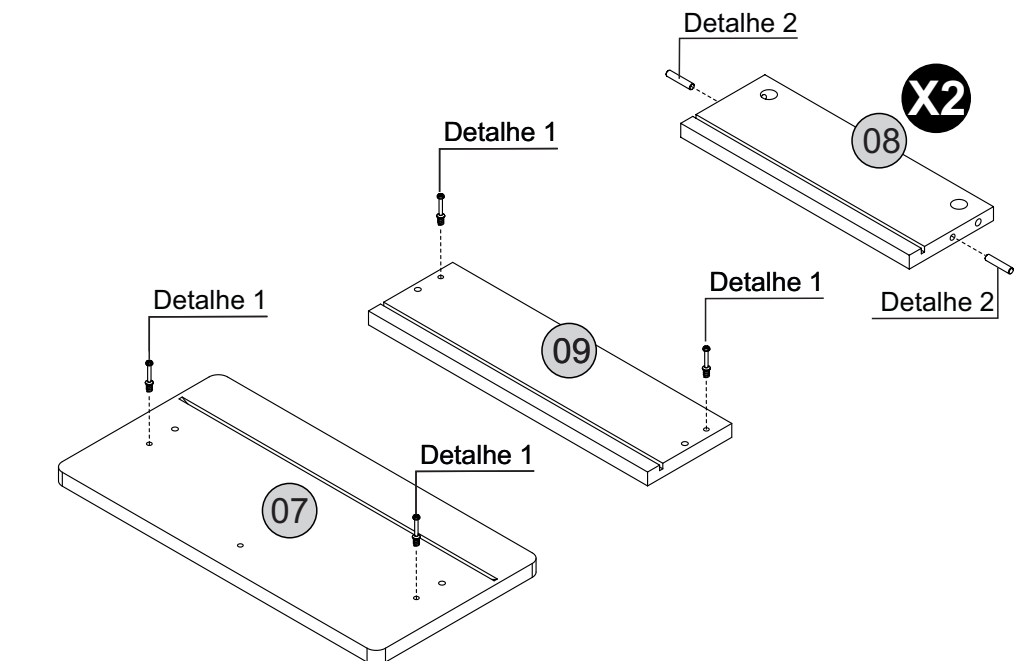
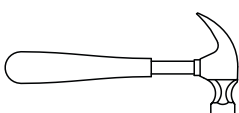
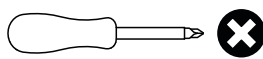

Detalhe 1
Detail/Detalle

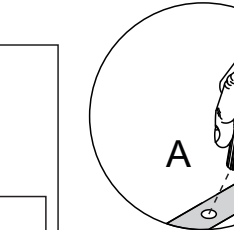
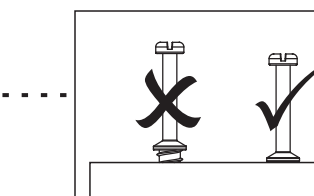

Detalhe 2
Detail/Detalle

Passo 7

Paso/Step

PEÇA
Piece/Pieza

11 - TRAVESSA PÉS x2

16 - TRAVESSA SUPERIOR x1

FERRAGEM
Hardware/Herraje

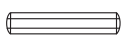
A  06

FERRAMENTA
Tool/Herramienta

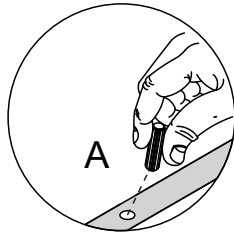
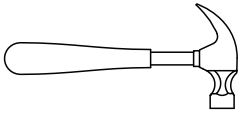

Detalhe 2
Detail/Detalle

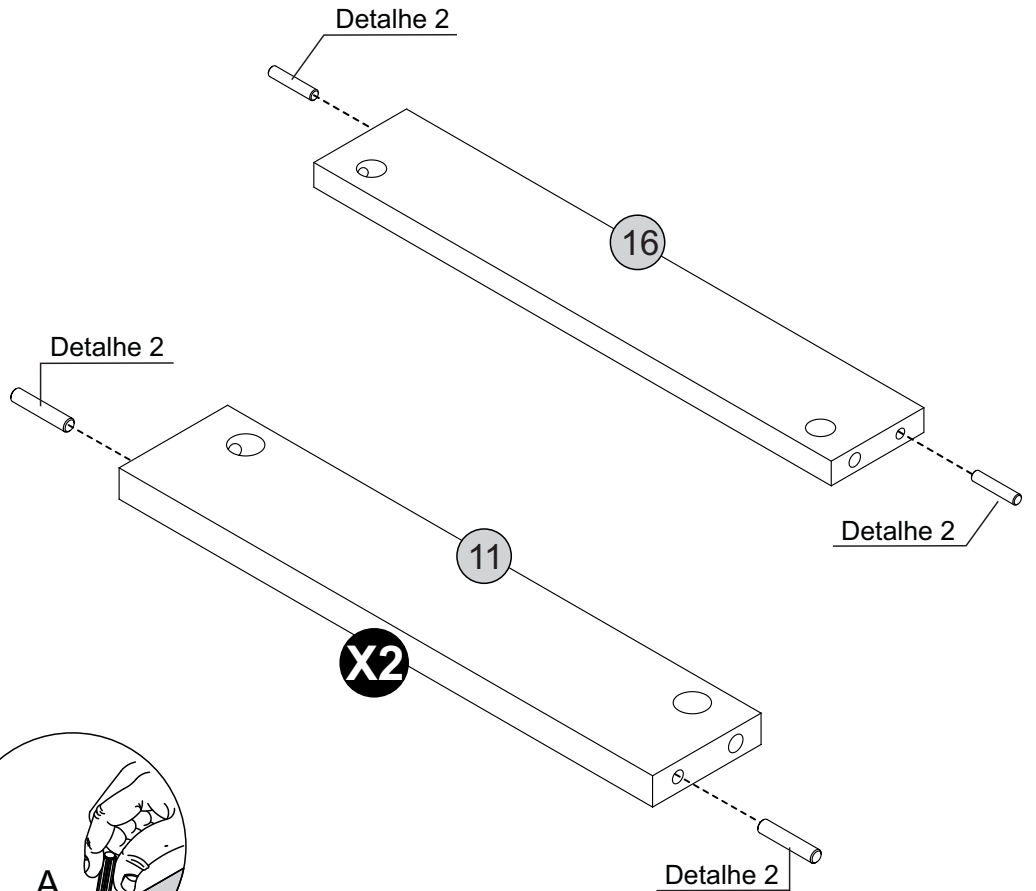

Passo 8

Paso/Step

PEÇA
Piece/Pieza

12 - PÉ DIREITO x2

13 - PÉ ESQUERDO x2

FERRAGEM
Hardware/Herraje

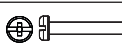
B  04

N  04

FERRAMENTA
Tool/Herramienta

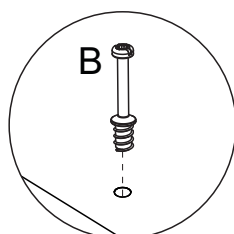
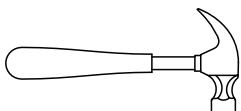
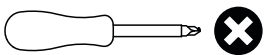

Detalhe 1
Detail/Detalle

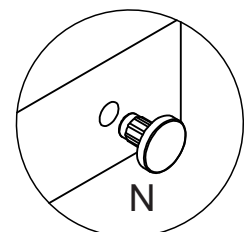
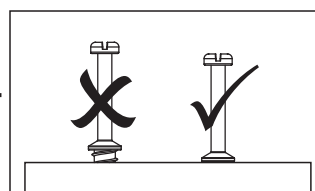
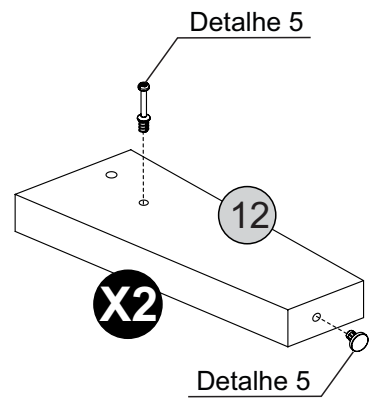
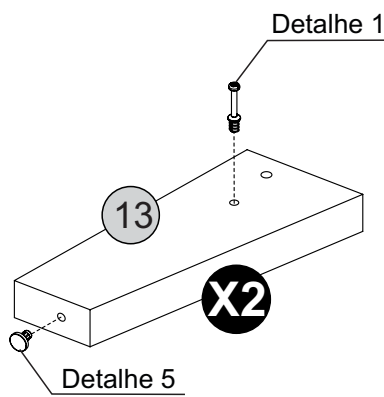

Detalhe 5
Detail/Detalle

Passo 9

Paso/Step

PEÇA
Piece/Pieza

14 - TAMPO MAIOR x1

FERRAGEM
Hardware/Herraje

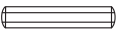
A  08

FERRAMENTA
Tool/Herramienta

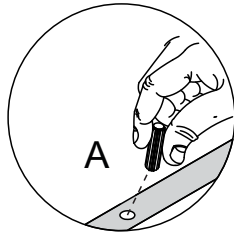
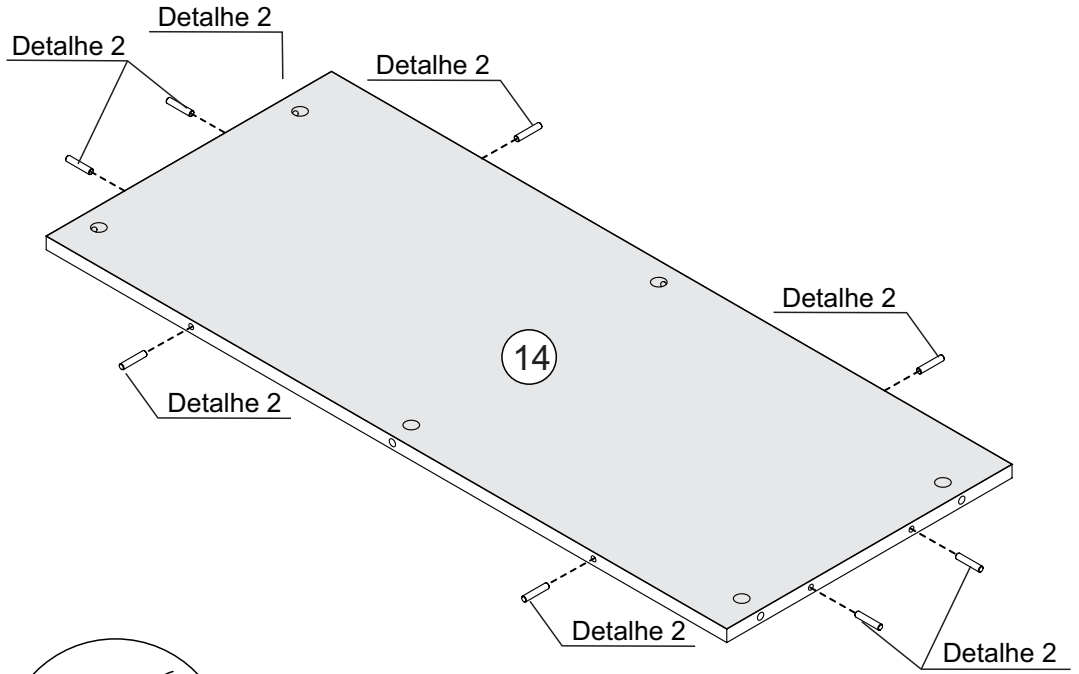
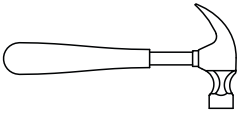

Detalhe 2
Detail/Detalle

Passo 10

Paso/Step

PEÇA
Piece/Pieza

15 - LATERAL MAIOR x1

FERRAGEM
Hardware/Herraje

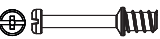
B  04

N  02

FERRAMENTA
Tool/Herramienta

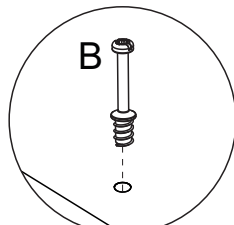
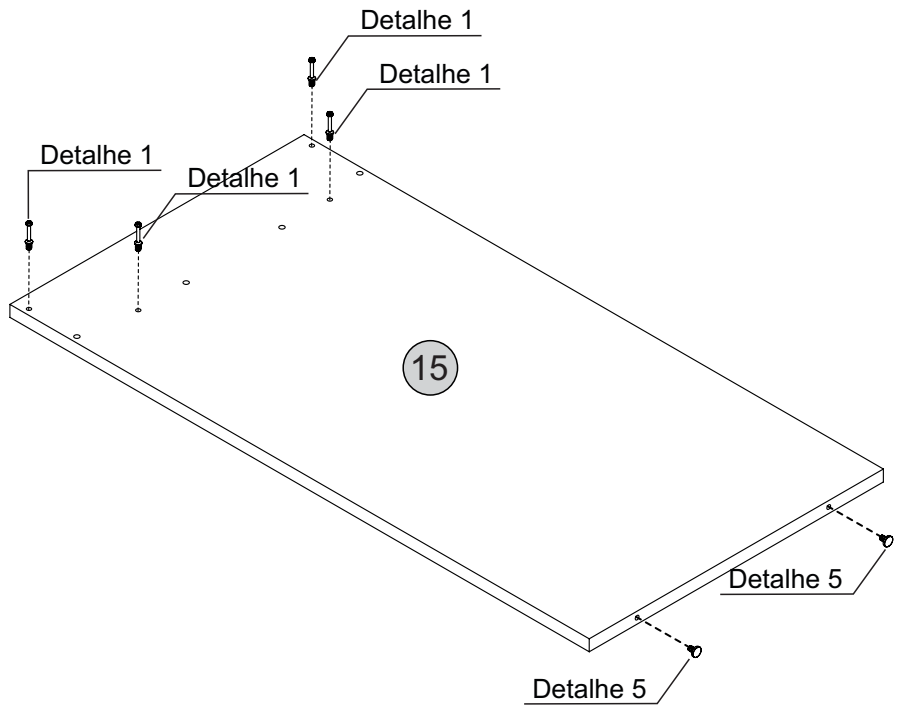
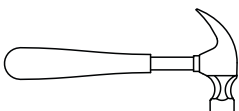
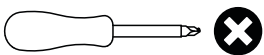

Detalhe 1
Detail/Detalle

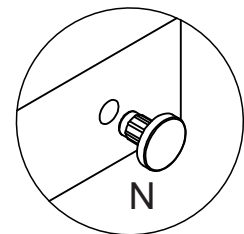
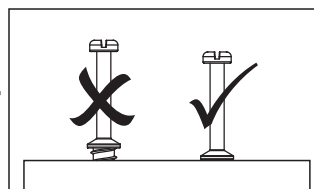

Detalhe 5
Detail/Detalle

Passo 17

Paso/Step

PEÇA

Piece/Pieza

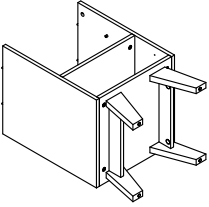



1 - TAMPO

x1

FERRAGEM

Hardware/Herraje

C   04

D  04

FERRAMENTA

Tool/Herramienta

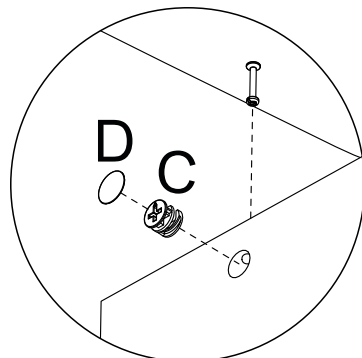
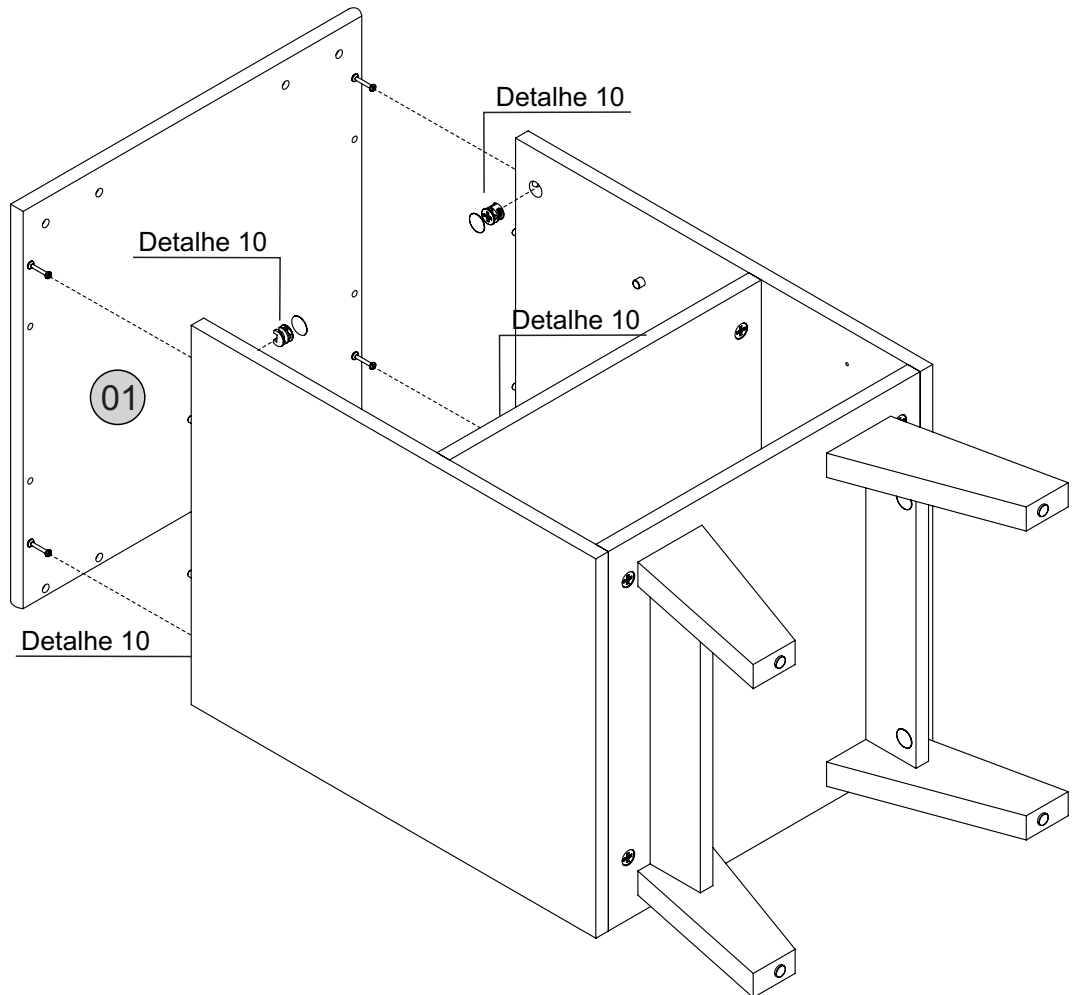
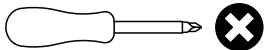

Detalhe 10
Detalle/Detail

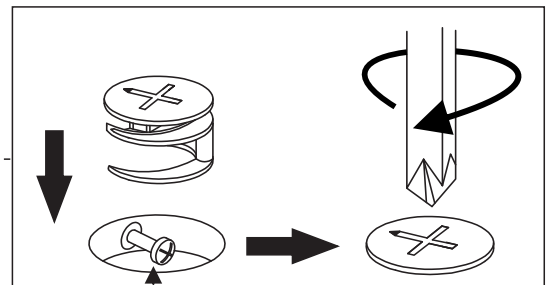

Cabeça do parafuso precisa estar no centro
La cabeza del tornillo debe estar en el centro
Screw head has to be in the center

Passo 18



Paso/Step

PEÇA Piece/Pieza

07 - Frente Gaveta x1

08 - Lateral Gaveta x2

FERRAGEM Hardware/Herraje

C   02

D  02

FERRAMENTA Tool/Herramienta

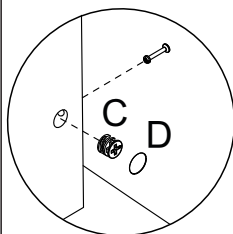
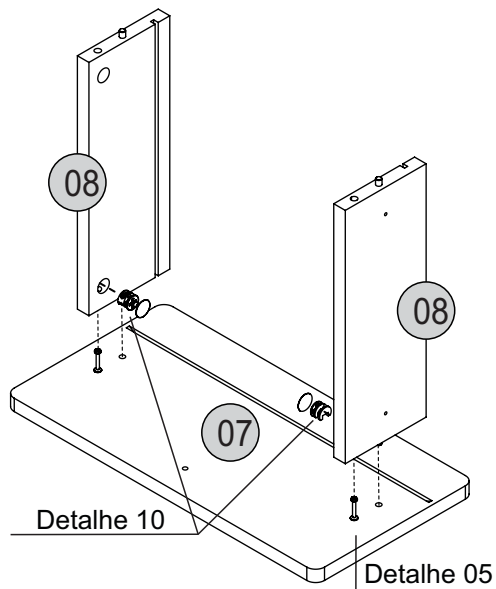
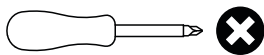

Detalhe 10
Detalle/Detail

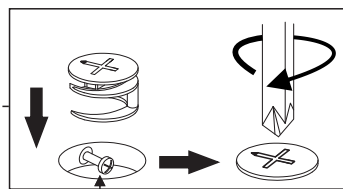

Cabeça do parafuso precisa estar no centro
La cabeza del tornillo debe estar en el centro
Screw head has to be in the center

Passo 19

Paso/Step

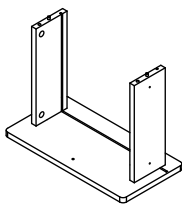

PEÇA Piece/Pieza



09 - Traseiro Gaveta x2

10 - Fundo Gaveta x2

FERRAGEM Hardware/Herraje

C   02

D  02

FERRAMENTA Tool/Herramienta

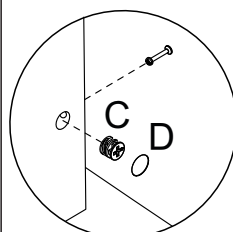
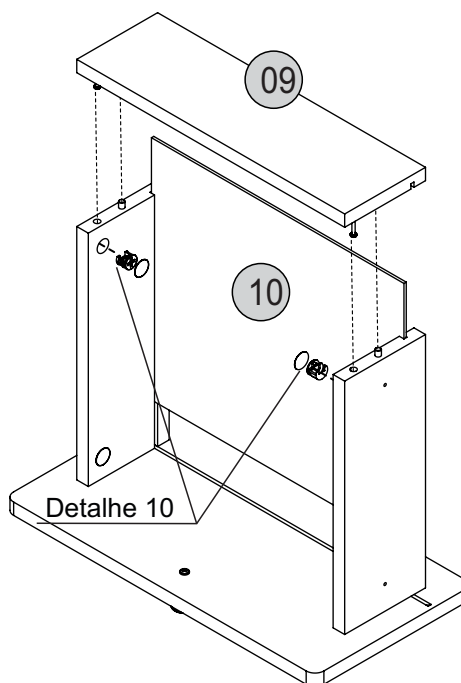
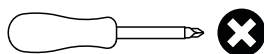

Detalhe 10
Detalle/Detail

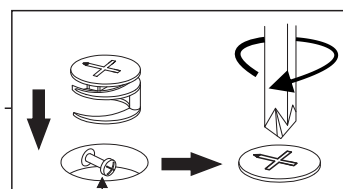

Cabeça do parafuso precisa estar no centro
La cabeza del tornillo debe estar en el centro
Screw head has to be in the center

Passo 20

Paso/Step

PEÇA
Piece/Pieza

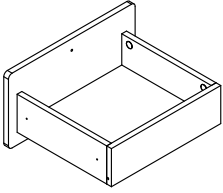

FERRAGEM
Hardware/Herraje

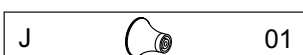
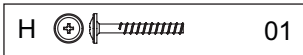
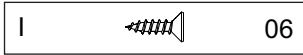

FERRAMENTA
Tool/Herramienta

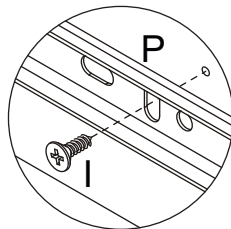
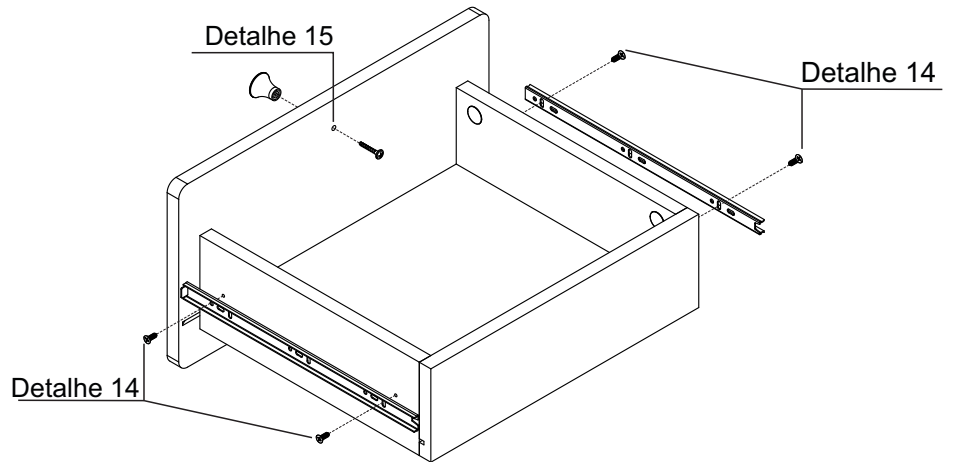
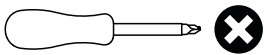

Detalhe 14
Detalle/Detail

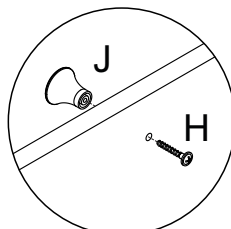

Detalhe 15
Detalle/Detail

**LOCAL DE FIXAÇÃO
DOS PARAFUSOS
NO TRILHO**

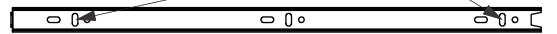

Passo 21

Paso/Step

PEÇA
Piece/Pieza

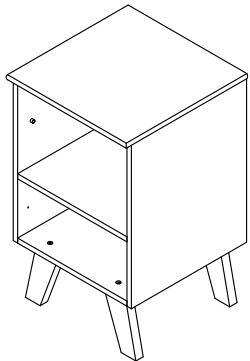
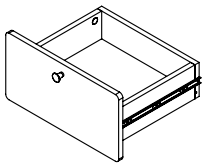

FERRAGEM
Hardware/Herraje

FERRAMENTA
Tool/Herramienta

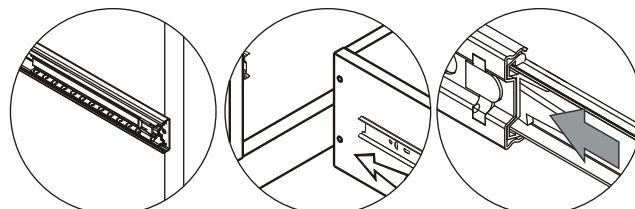
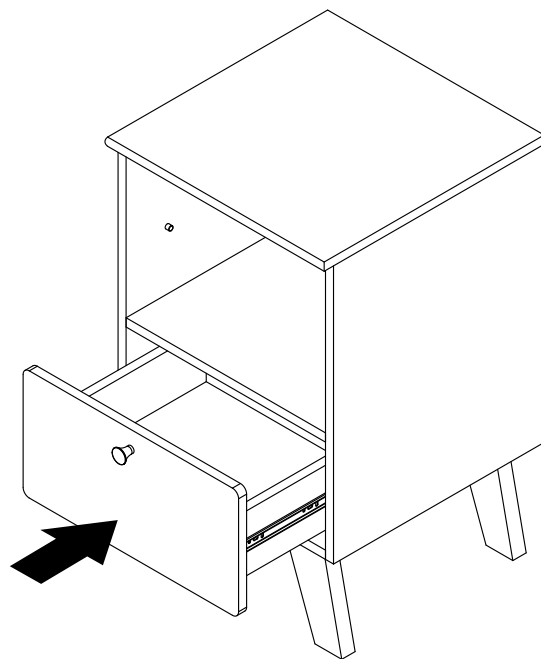

ATENÇÃO: Sempre quando colocar as gavetas, verifique que os trilhos estejam com os ralamentos alinhados na frente.

Passo 26A

Paso/Step

PEÇA
Piece/Pieza

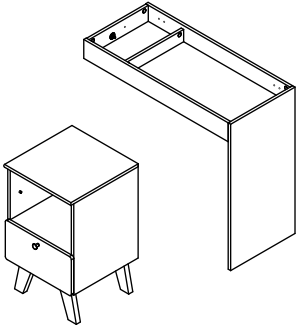

FERRAGEM
Hardware/Herraje



FERRAMENTA
Tool/Herramienta

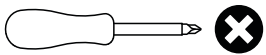

Opção A

Opción A
Option A

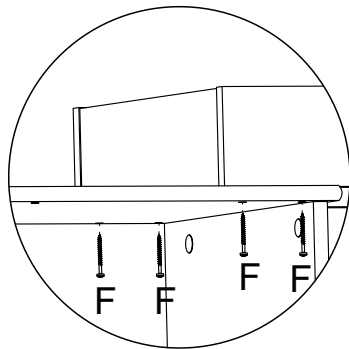
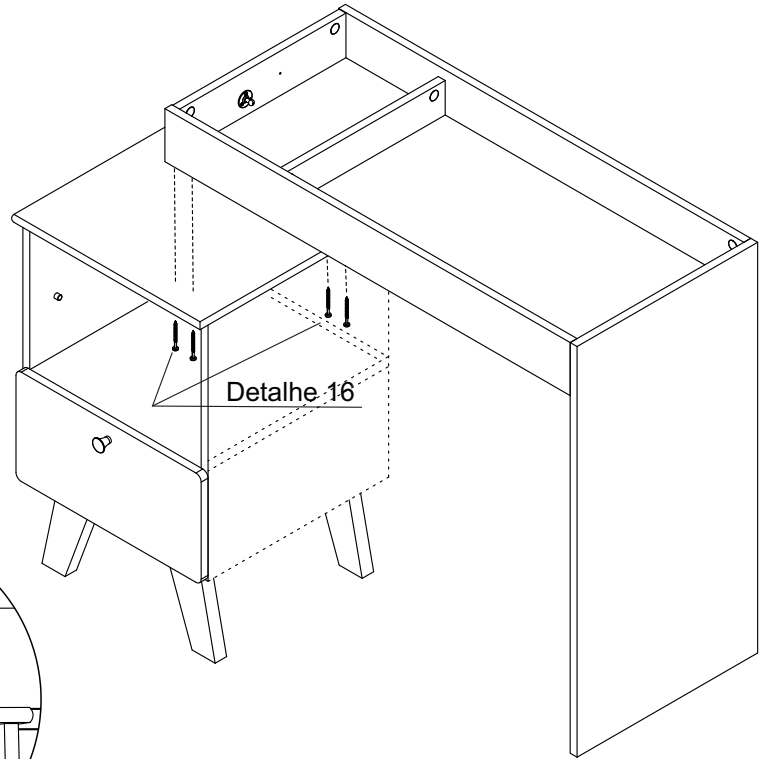
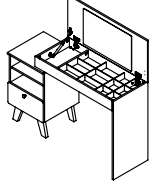

Detalhe 16
Detalle/Detail

Passo 26B

Paso/Step

PEÇA
Piece/Pieza

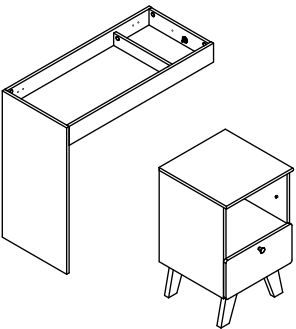

FERRAGEM
Hardware/Herraje



FERRAMENTA
Tool/Herramienta

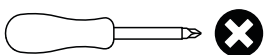

Opção B

Opción B
Option B

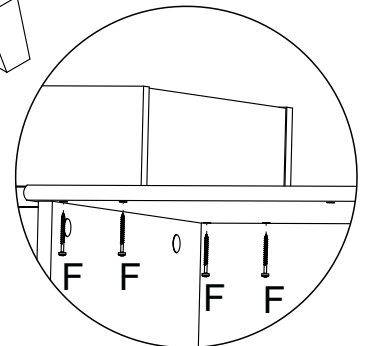
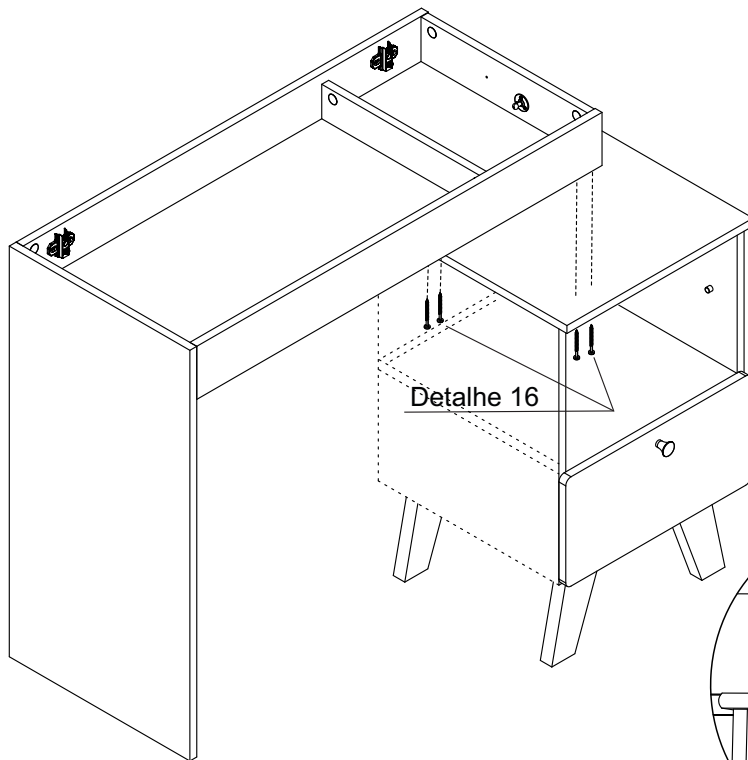
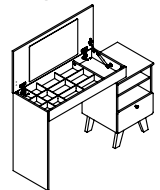

Detalhe 16
Detalle/Detail

Passo 27

Paso/Step

PEÇA
Piece/Pieza

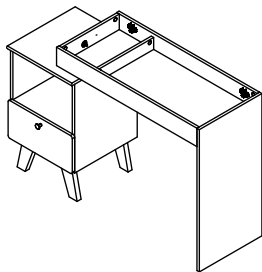

4 - PRATELEIRA MÓVEL x1

FERRAGEM
Hardware/Herraje

FERRAMENTA
Tool/Herramienta

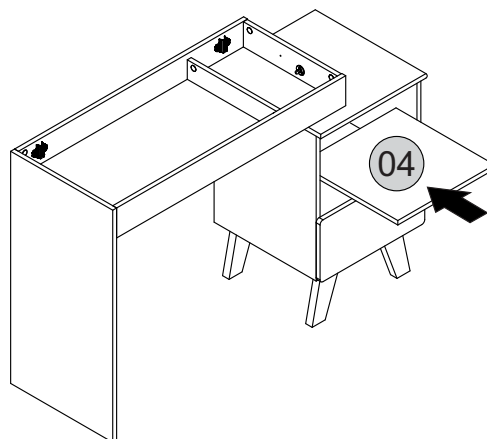
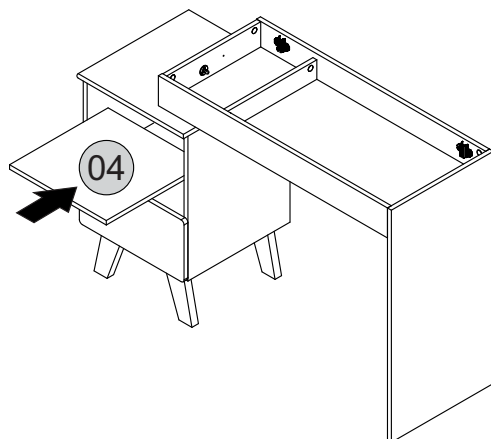
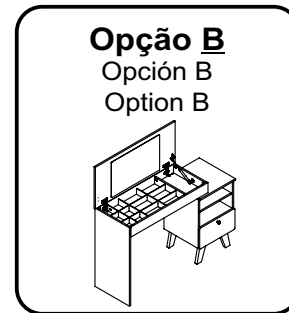

Passo 28

Paso/Step

PEÇA
Piece/Pieza

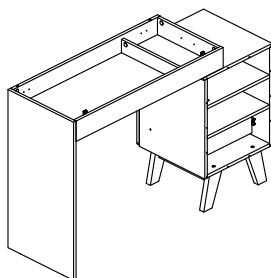

23 - TRASEIRO x1

FERRAGEM
Hardware/Herraje

○ ———▶ 14

FERRAMENTA
Tool/Herramienta

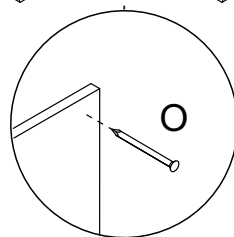
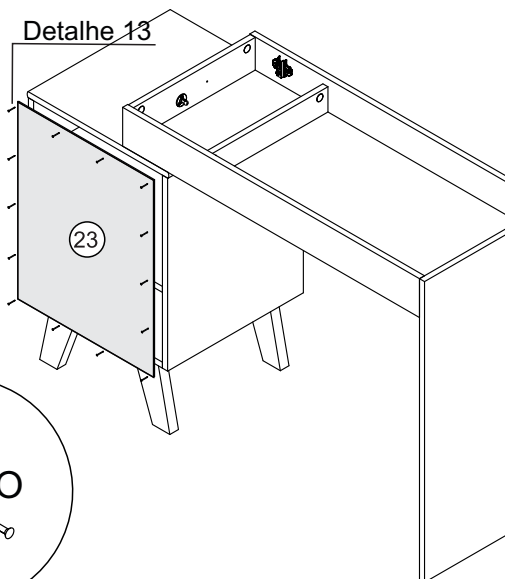
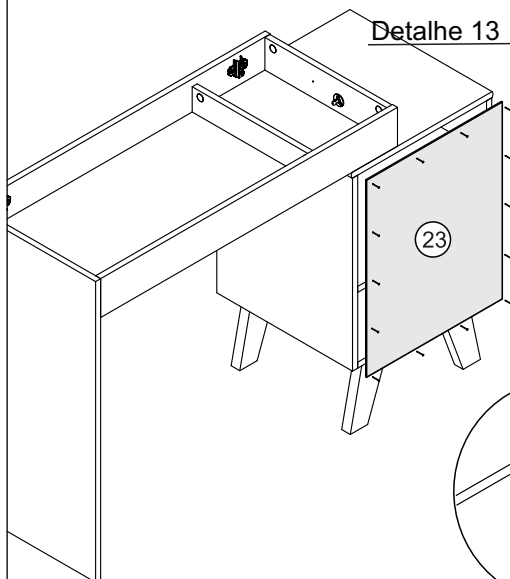
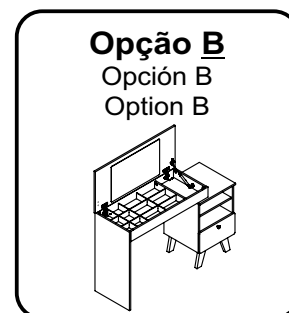
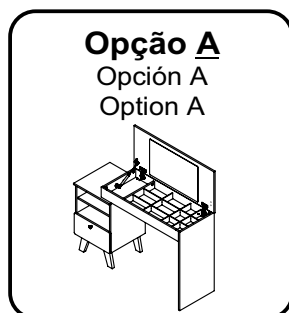
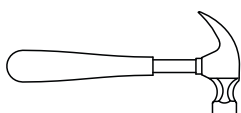

Detalhe 13
Detail/Detalle

Passo 30A

Paso/Step

PEÇA
Piece/Pieza

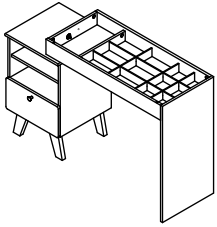

20 - PORTA

x1

FERRAGEM
Hardware/Herraje

Q1  01

FERRAMENTA
Tool/Herramienta

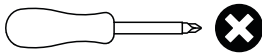

Opção A
Opción A
Option A

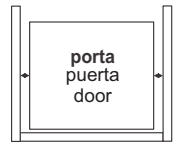
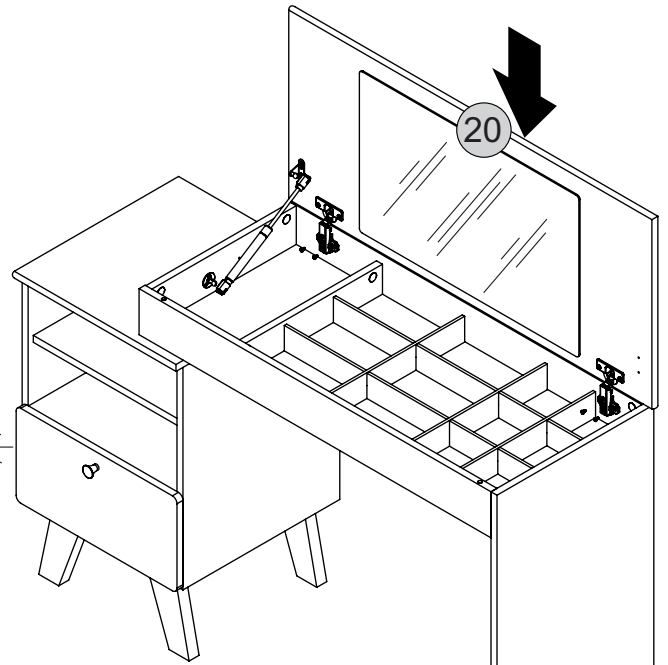
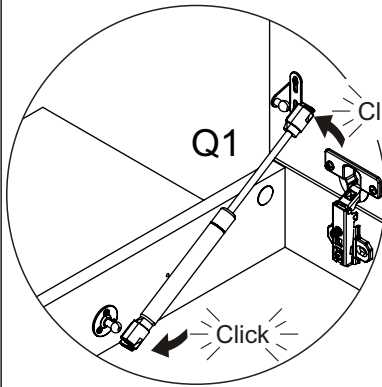
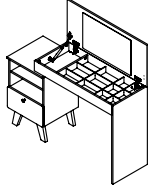

Ajuste de Largura
Ajuste de ancho
Width Adjustment

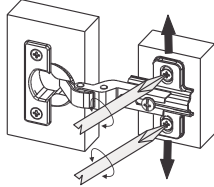

Ajuste Interno
Ajuste Interno
Internal Adjustment

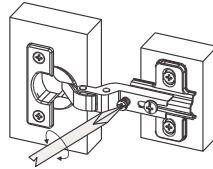

Ajuste de Profundidade
Ajuste de profundidad
Depth Adjustment

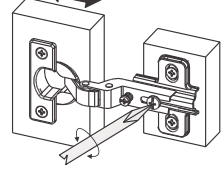

Passo 30B

Paso/Step

PEÇA
Piece/Pieza

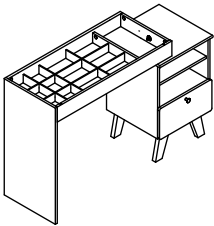

20 - PORTA

x1

FERRAGEM
Hardware/Herraje

Q1  01

FERRAMENTA
Tool/Herramienta

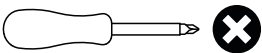

20

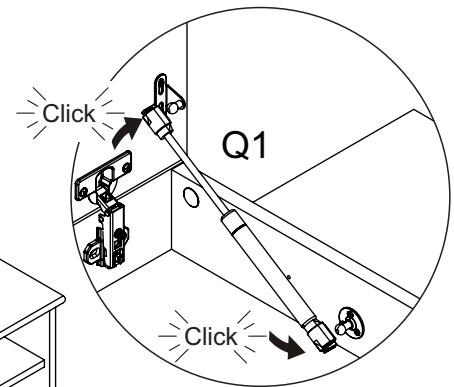
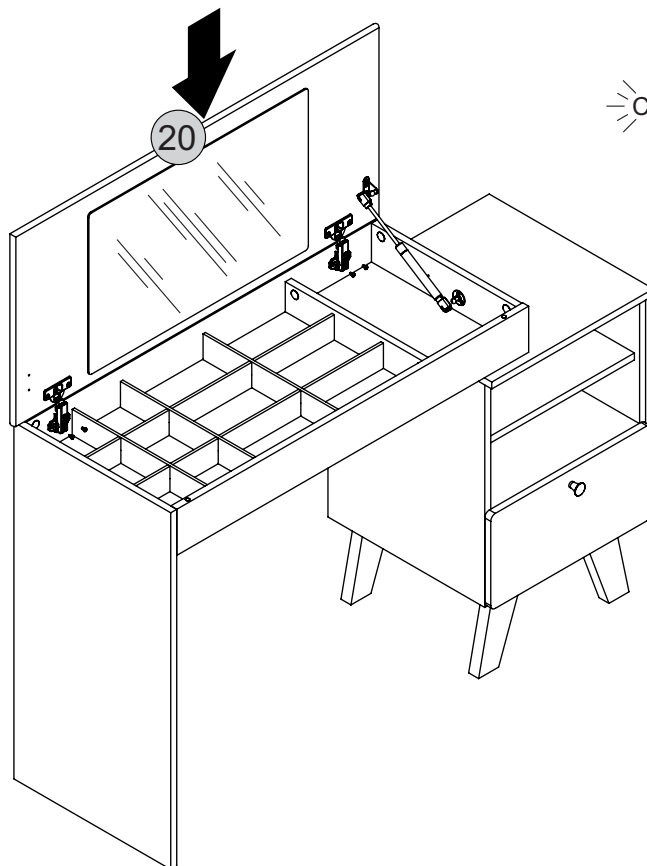

Opção B
Opción B
Option B

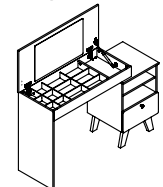

Passo 31

Paso/Step

PEÇA
Piece/Pieza

FERRAGEM
Hardware/Herraje

FERRAMENTA
Tool/Herramienta

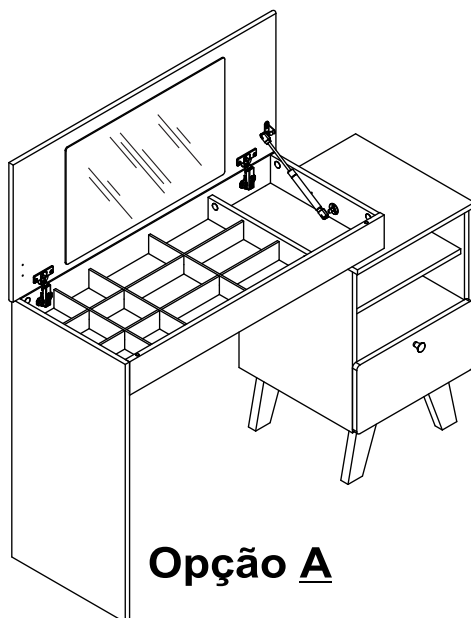

Opção A

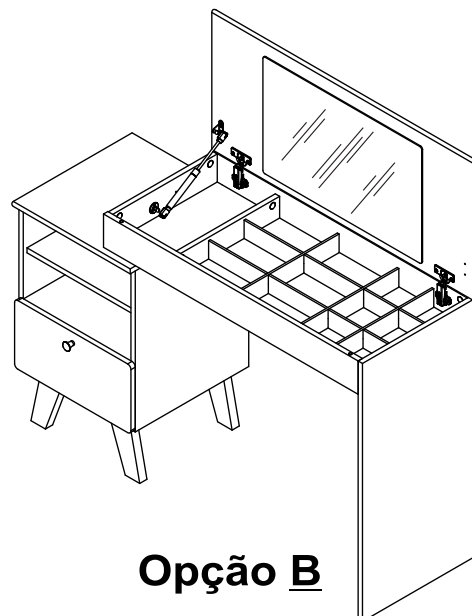

Opção B

Parabéns, você montou seu móvel! Agora é só decorar sua casa e aproveitar!

Queremos ver como ficou o móvel Artely do seu jeito... Marque a gente com a #meuartely. Ficaremos felizes em compartilhar!

Ah, e se tiver qualquer dúvida, sugestão ou comentário, entra em contato com a gente pelo nosso site www.artely.com.br.

¡Congratulaciones, montaste tu mueble! ¡Ahora solo decora tu casa y disfruta!

Queremos ver este producto en tu hogar, a tu manera... Utilice #meuartely, ¡ficaremos encantados de compartir tu foto!

Si tienes alguna duda, sugerencia o comentario, contáctenos a través de nuestro sitio web www.artely.com.br.

Congratulations, you've assembled your new furniture! Decorate your home and enjoy!

We want to see how this product is in your home... Use #meuartely, we will be happy to share your picture!

If you have any doubt, suggestion or comment, get in touch with us through our website www.artely.com.br.