

ASSEMBLY INSTRUCTIONS MANUAL DE MONTAGEM / INSTRUCCIONES DE ARMADO

FRANÇA DRESSING TABLE
PENTEADEIRA FRANÇA
TOCADOR FRANÇA

Reference
Referência
Referencia **170487** | Revise
| Revisão
| Revisión **04**

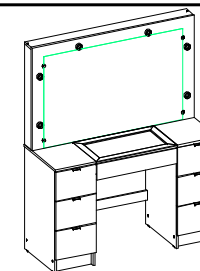

YOU WILL NEED VOCÊ VAI PRECISAR DE / USTED NECESITARÁ

Tools not supplied
Ferramentas não fornecidas / Herramientas no incluidas

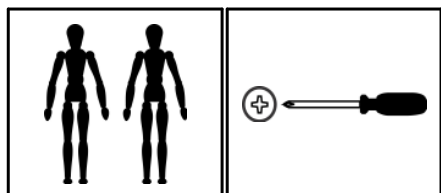

2 People
2 Pessoas
2 Personas

Screwdriver Phillips
Chave Phillips
Destornillador cruz

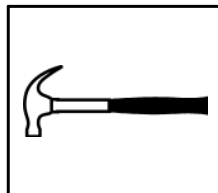

Hammer
Martelo
Martillo

PARTS IDENTIFICATION IDENTIFICAÇÃO DAS PEÇAS / IDENTIFICACIÓN DE LAS PIEZAS

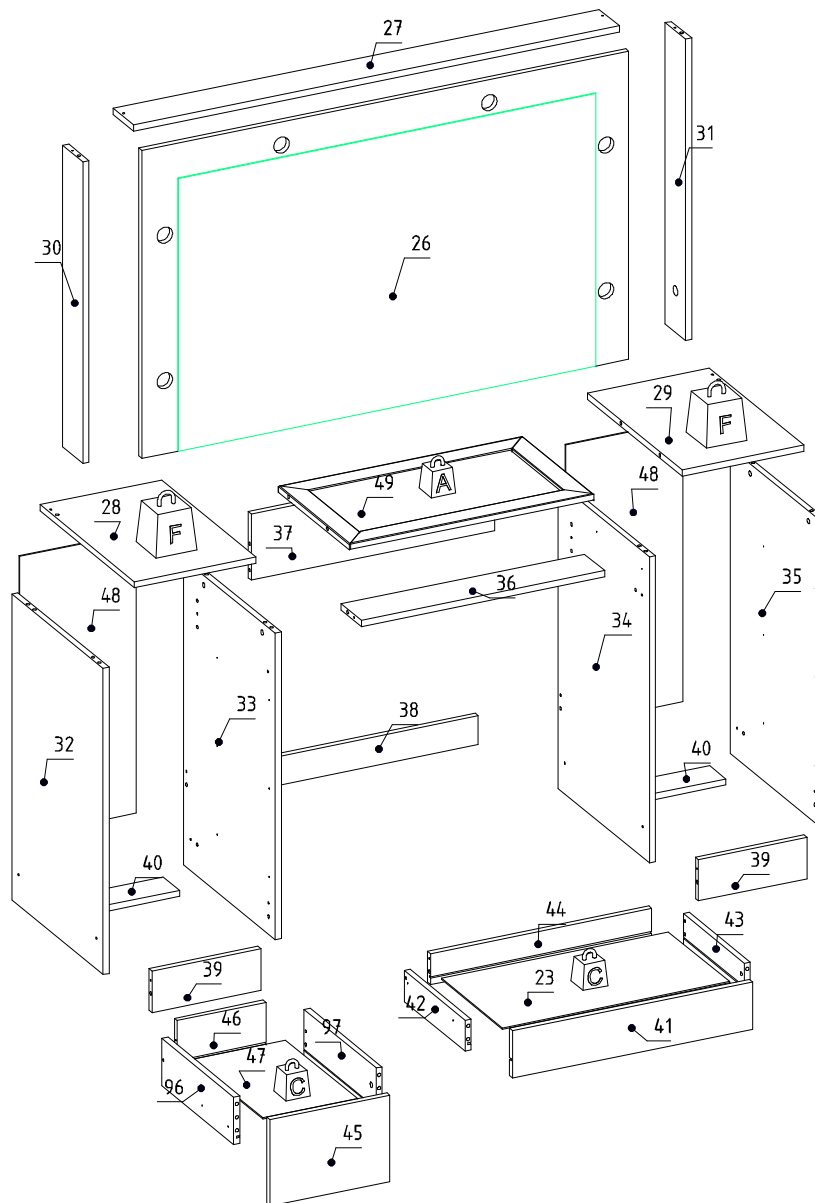

Nº	Measures_Inches	Medidas_cm	Qty./Qtd.
23	22 x 11 3/4 x 1/8	56.0 x 30.0 x 0.3	1
26	47 1/4 x 29 3/8 x 5/8	120.0 x 74.5 x 1.5	1
27	47 1/8 x 3 7/8 x 5/8	119.8 x 10.0 x 1.5	1
28	11 3/4 x 18 1/4 x 5/8	30.0 x 46.5 x 1.5	1
29	11 3/4 x 18 1/4 x 5/8	30.0 x 46.5 x 1.5	1
30	28 5/8 x 3 7/8 x 5/8	72.8 x 10.0 x 1.5	1
31	28 5/8 x 3 7/8 x 5/8	72.8 x 10.0 x 1.5	1
32	29 1/8 x 17 3/4 x 5/8	74.0 x 45.0 x 1.5	1
33	29 1/8 x 17 3/4 x 5/8	74.0 x 45.0 x 1.5	1
34	29 1/8 x 17 3/4 x 5/8	74.0 x 45.0 x 1.5	1
35	29 1/8 x 17 3/4 x 5/8	74.0 x 45.0 x 1.5	1
36	23 5/8 x 3 7/8 x 5/8	60.0 x 10.0 x 1.5	1
37	23 5/8 x 6 1/4 x 5/8	60.0 x 16.0 x 1.5	1
38	23 5/8 x 2 3/4 x 5/8	60.0 x 7.0 x 1.5	1
39	10 1/2 x 3 7/8 x 5/8	26.8 x 10.0 x 1.5	2
40	10 1/2 x 3 1/8 x 5/8	26.8 x 8.0 x 1.5	2
41	23 1/4 x 4 1/2 x 5/8	59.2 x 11.5 x 1.5	1
42	11 3/4 x 3 x 5/8	30.0 x 7.5 x 1.5	1
43	11 3/4 x 3 x 5/8	30.0 x 7.5 x 1.5	1
44	21 1/2 x 3 x 5/8	54.5 x 7.5 x 1.5	1
45	8 1/4 x 11 5/8 x 5/8	20.9 x 29.6 x 1.5	6
46	8 5/8 x 4 1/2 x 5/8	21.9 x 11.5 x 1.5	6
47	13 7/8 x 9 1/8 x 1/8	35.4 x 23.3 x 0.3	6
48	26 3/4 x 11 3/8 x 1/8	67.8 x 28.8 x 0.3	2
49	23 5/8 x 13 3/4 x 1/8	600 x 350 x 15	1
96	14 x 4 1/2 x 5/8	35.5 x 11.5 x 1.5	6
97	14 x 4 1/2 x 5/8	35.5 x 11.5 x 1.5	6

 MAXIMUM RECOMMENDED WEIGHT BEING THIS EVENLY DISTRIBUTED.
PESO MÁXIMO RECOMENDADO SENDO ESTE DISTRIBUÍDO UNIFORMEMENTE.
PESO MÁXIMO RECOMENDADO SIENDO ESTE UNIFORMEMENTE DISTRIBUIDO.

	LB	KG
—		
A	2	1
C	6	3
F	22	10

PRE-ASSEMBLE
PRÉ-MONTAGEM / PRE ARMADO

01

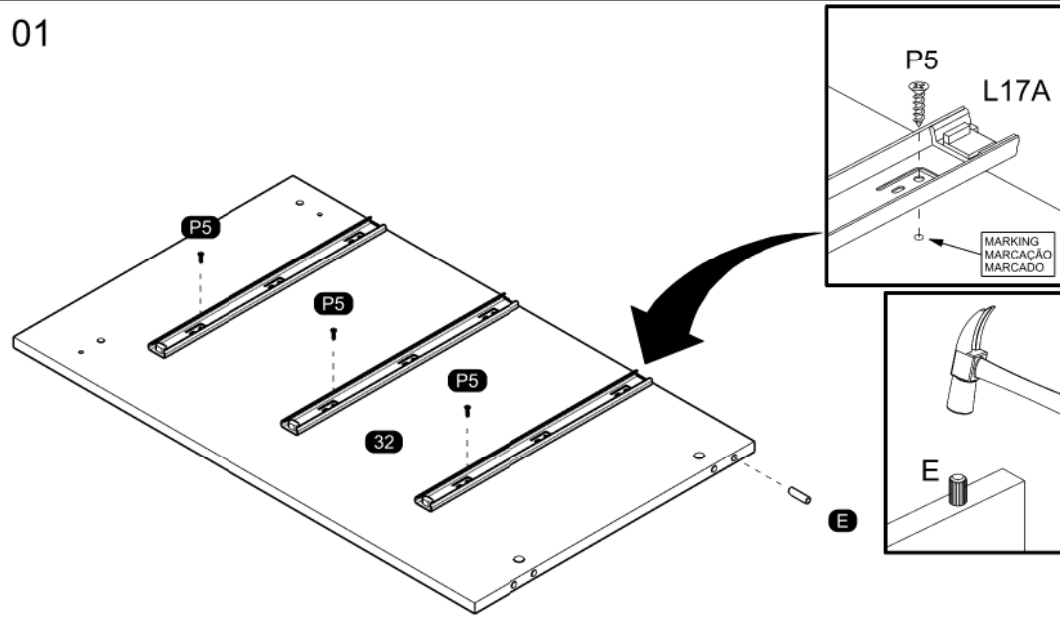

03

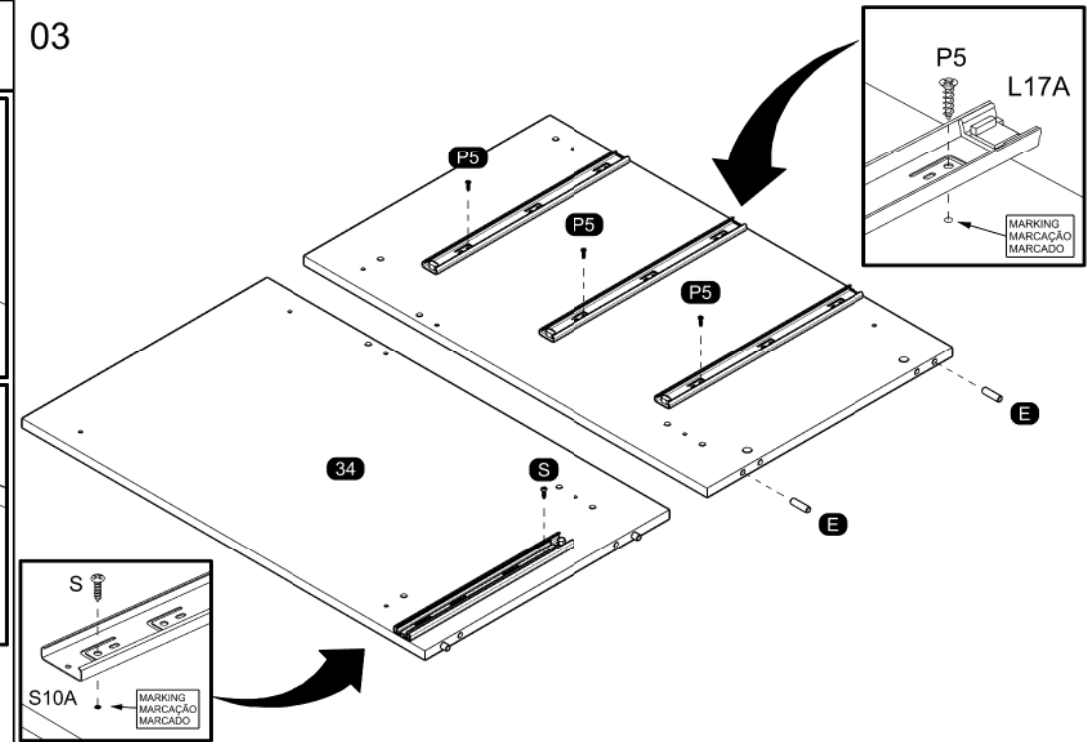

02

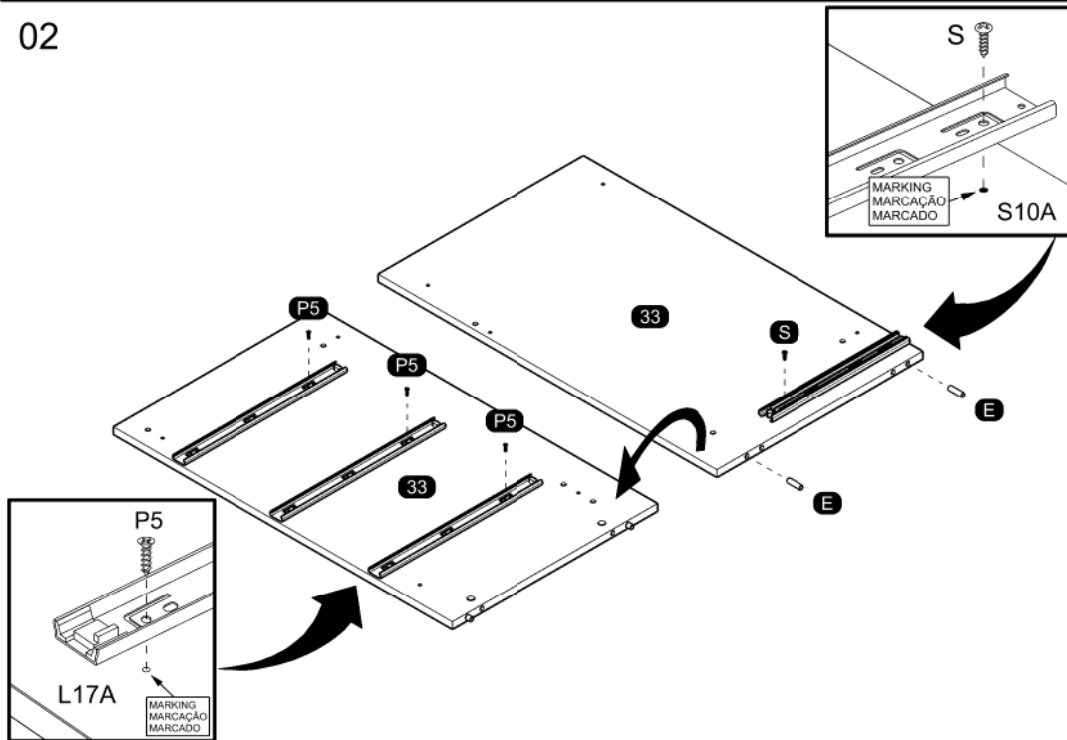

04

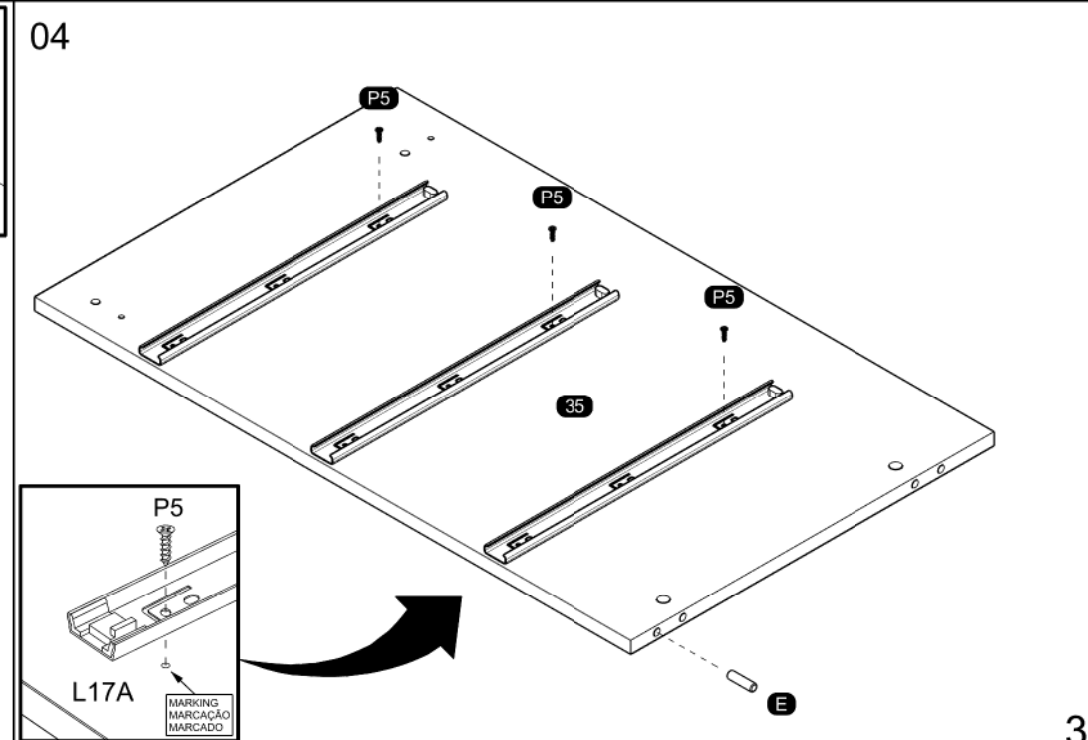

05

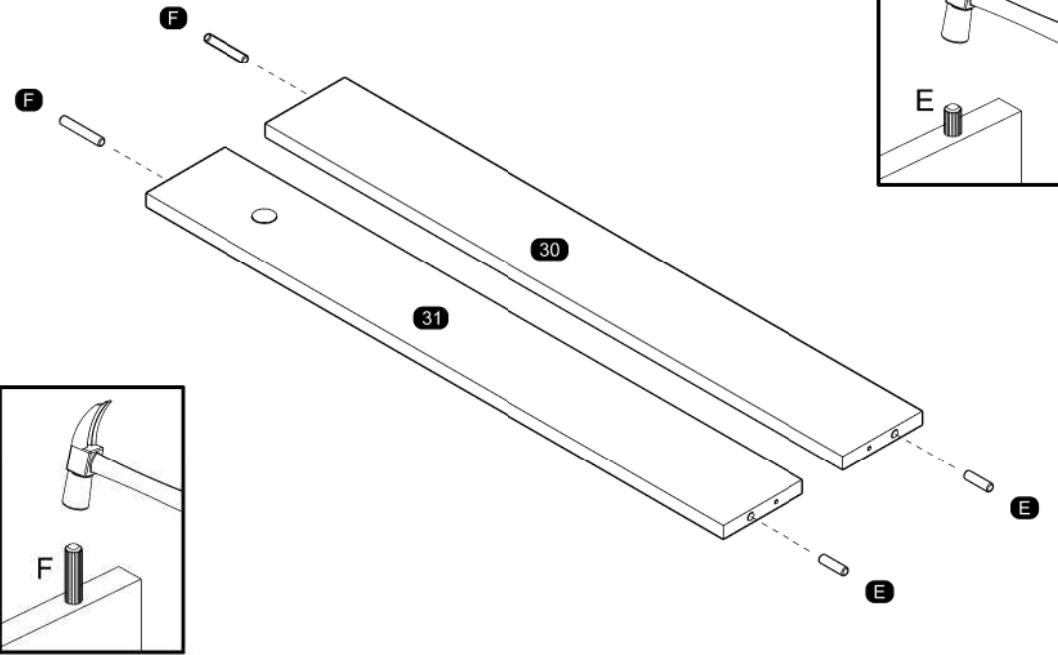

07

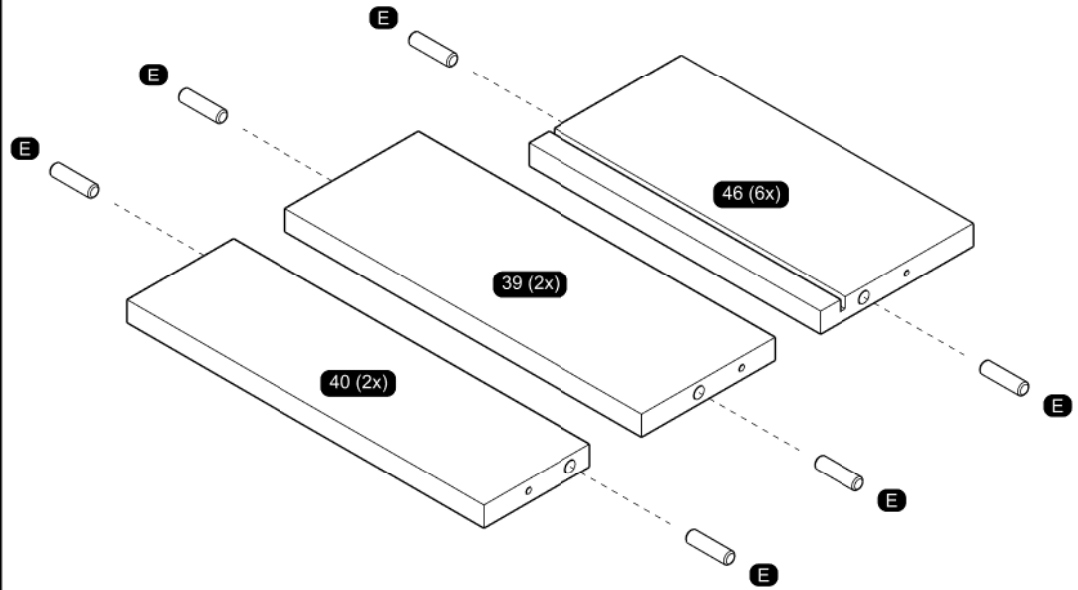

06

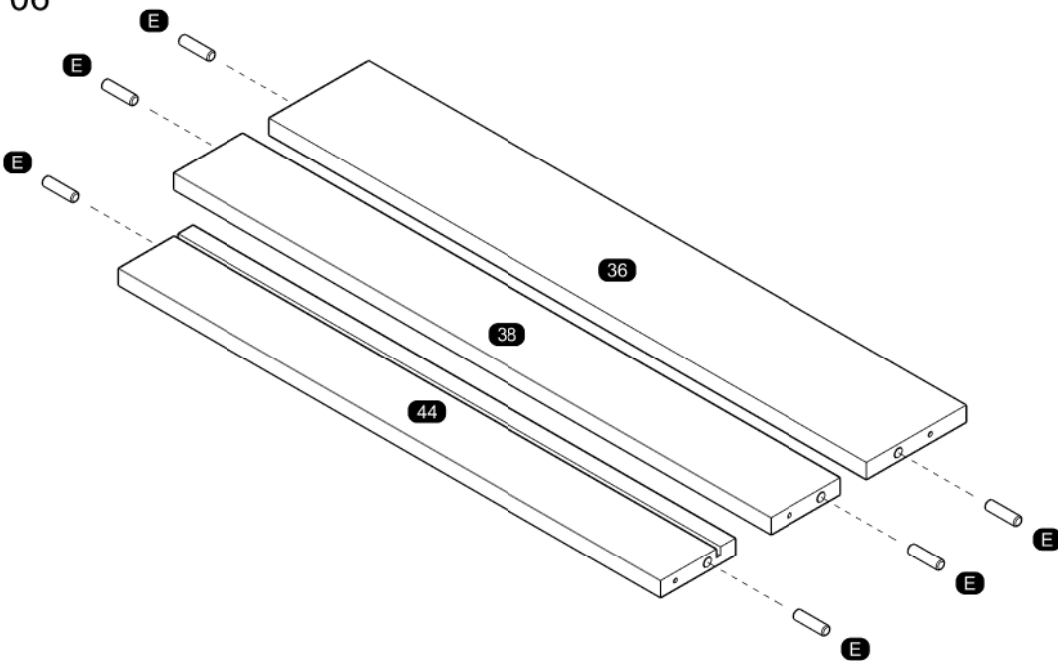

08

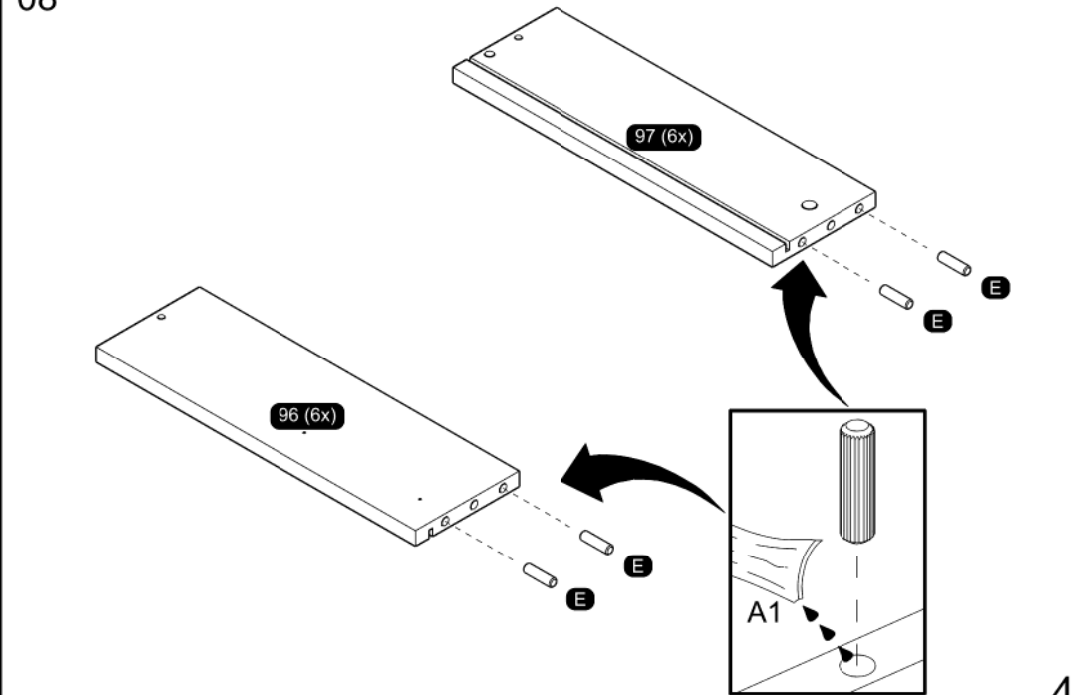

09

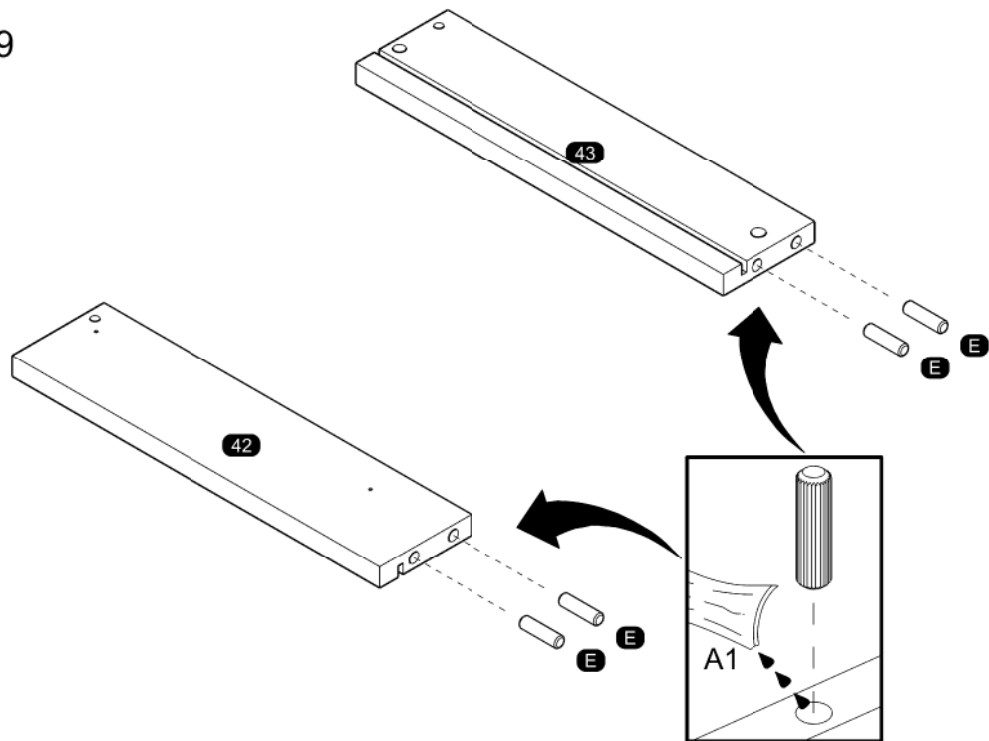

11

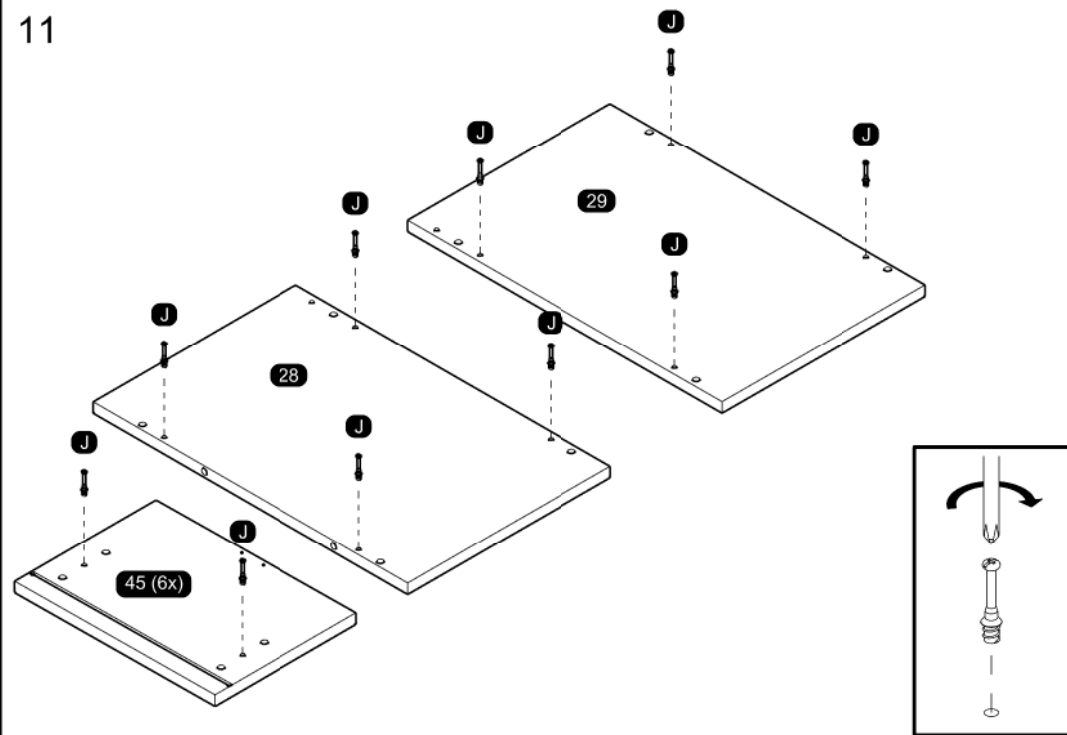

10

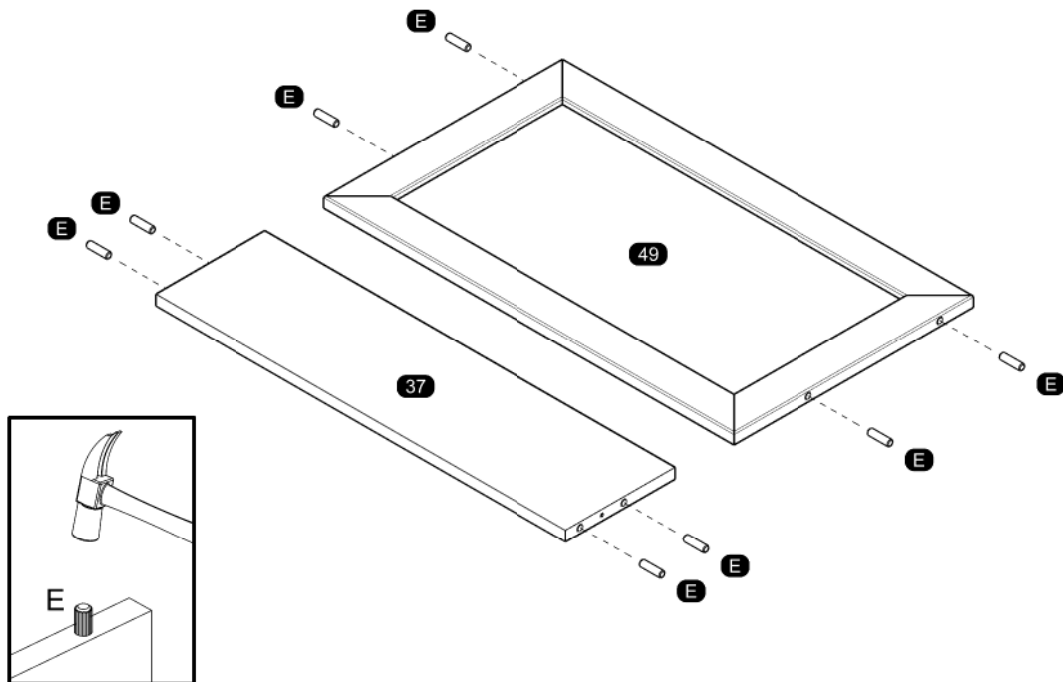

12

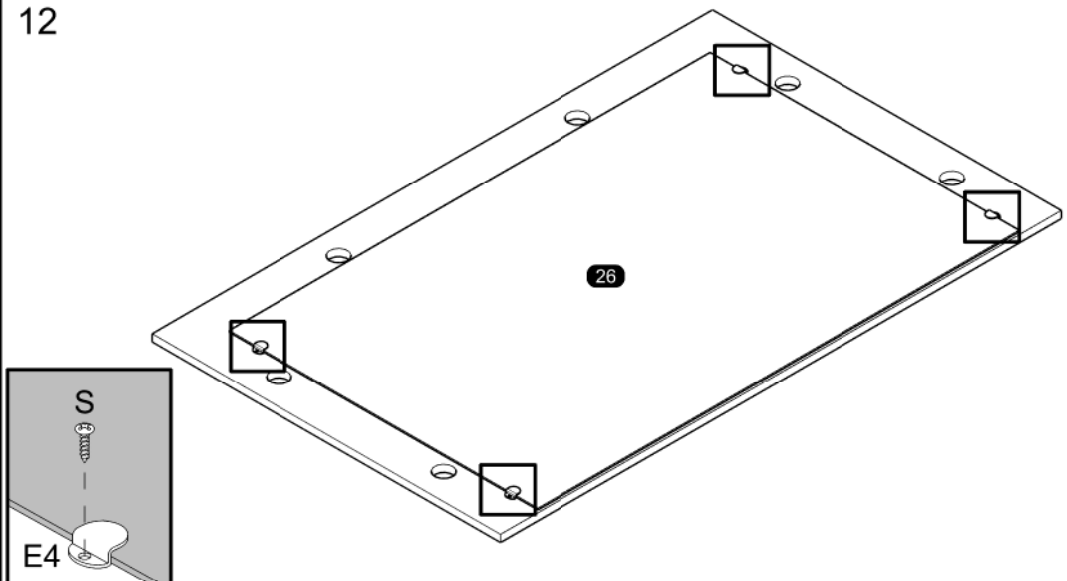

IMPORTANT! / IMPORTANTE! / ¡IMPORTANTE!
 It's essential to fixing the accessory "E4" for safety.
 É imprescindível a fixação do acessório "E4" por segurança.
 Es esencial fijar el accesorio "E4" para la seguridad.

**ASSEMBLY
MONTAGEM / ARMADO**

13

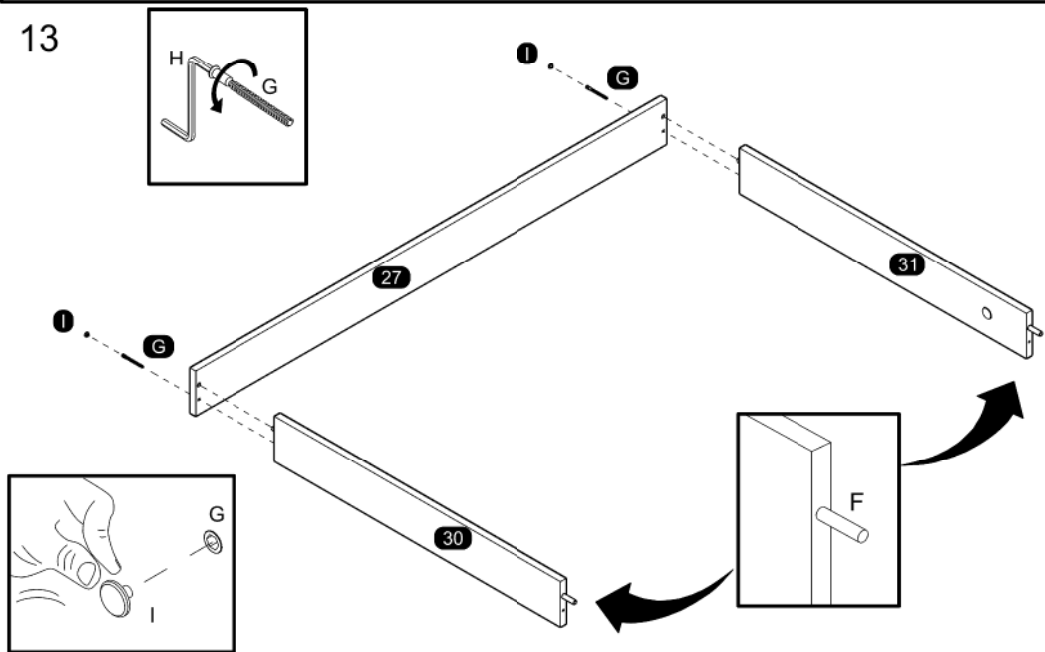

14

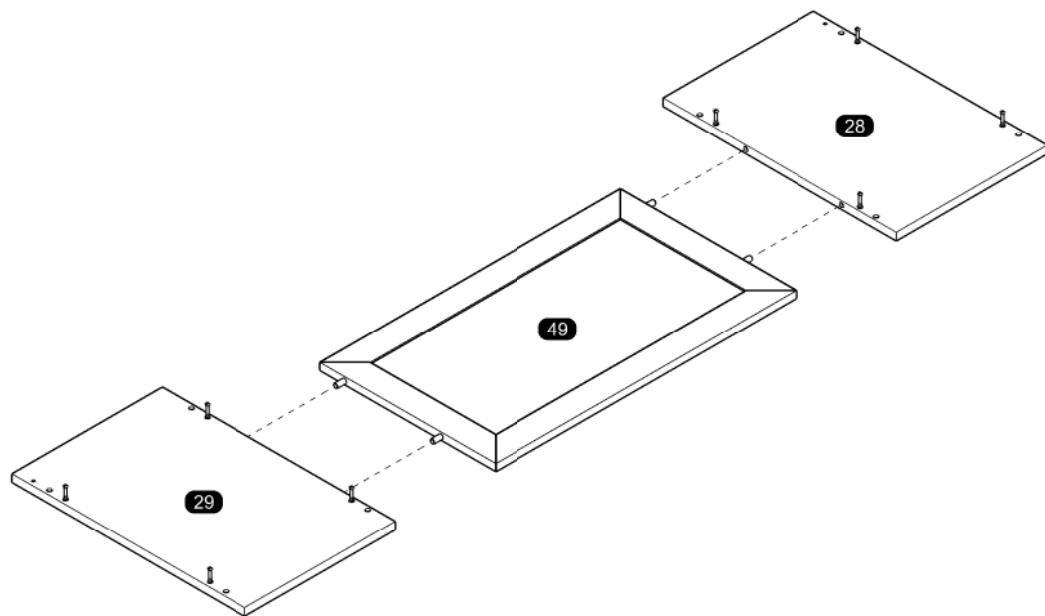

15

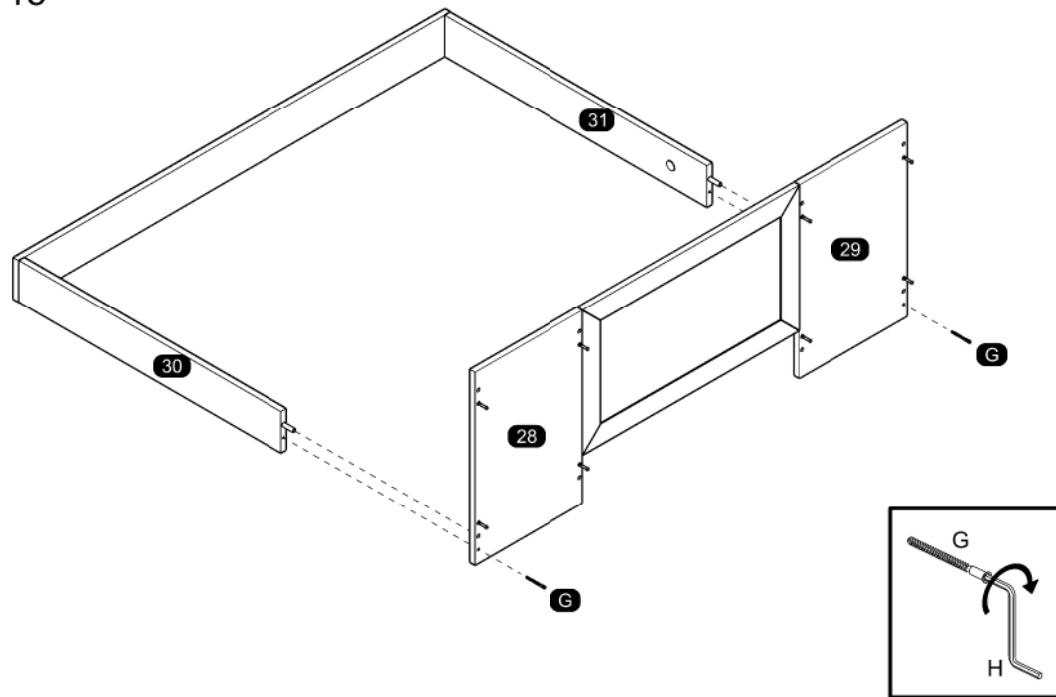

16

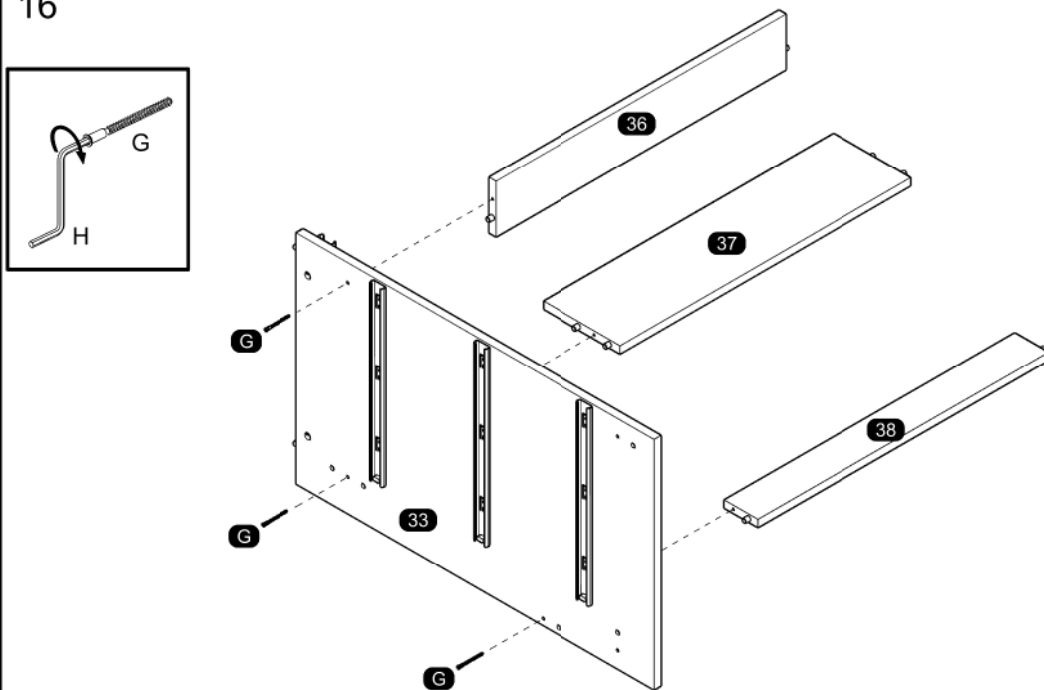

17

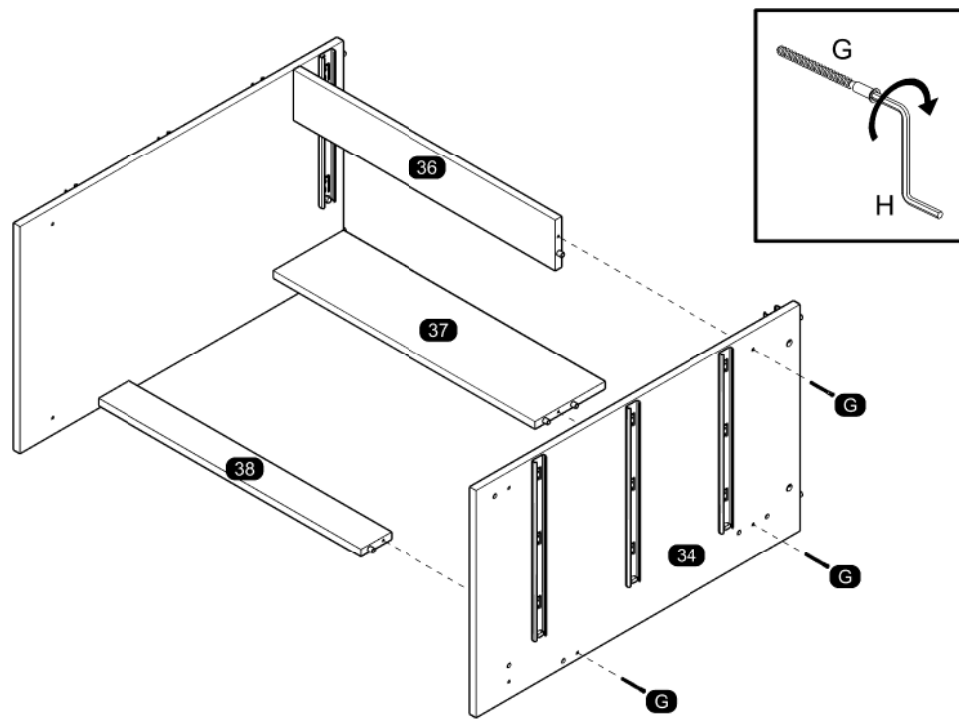

19

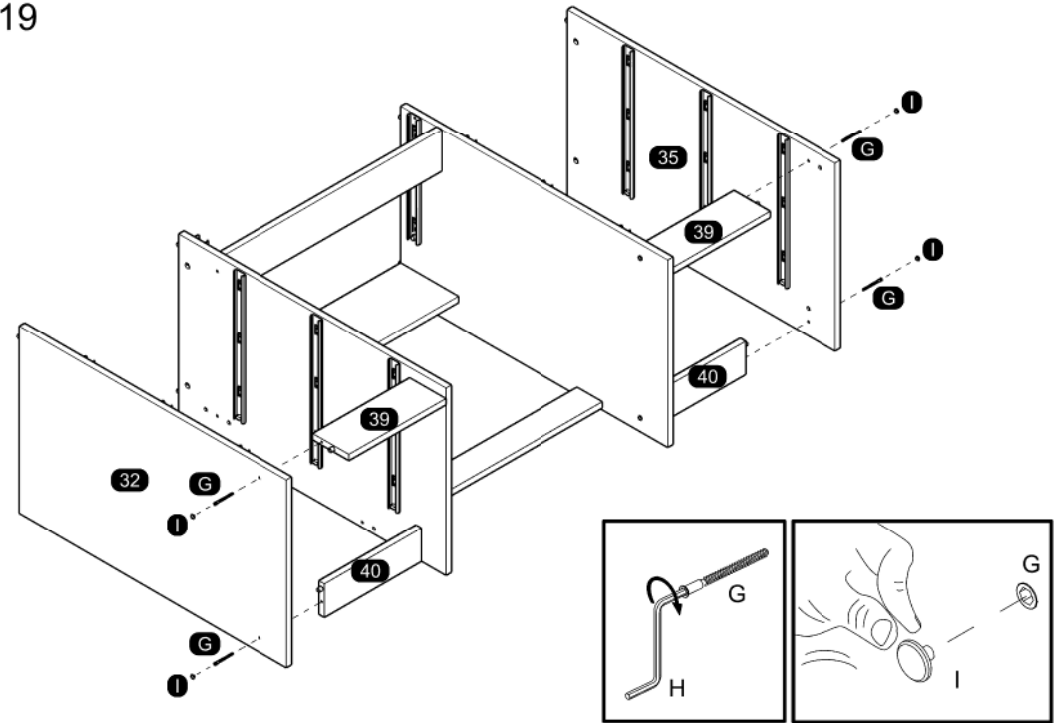

18

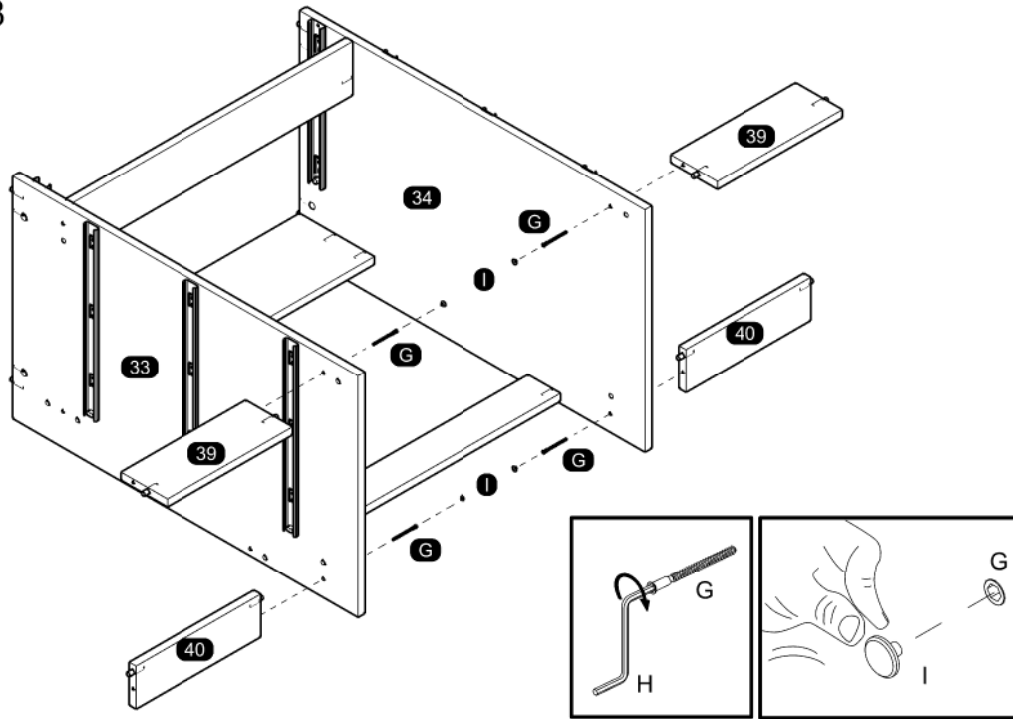

20

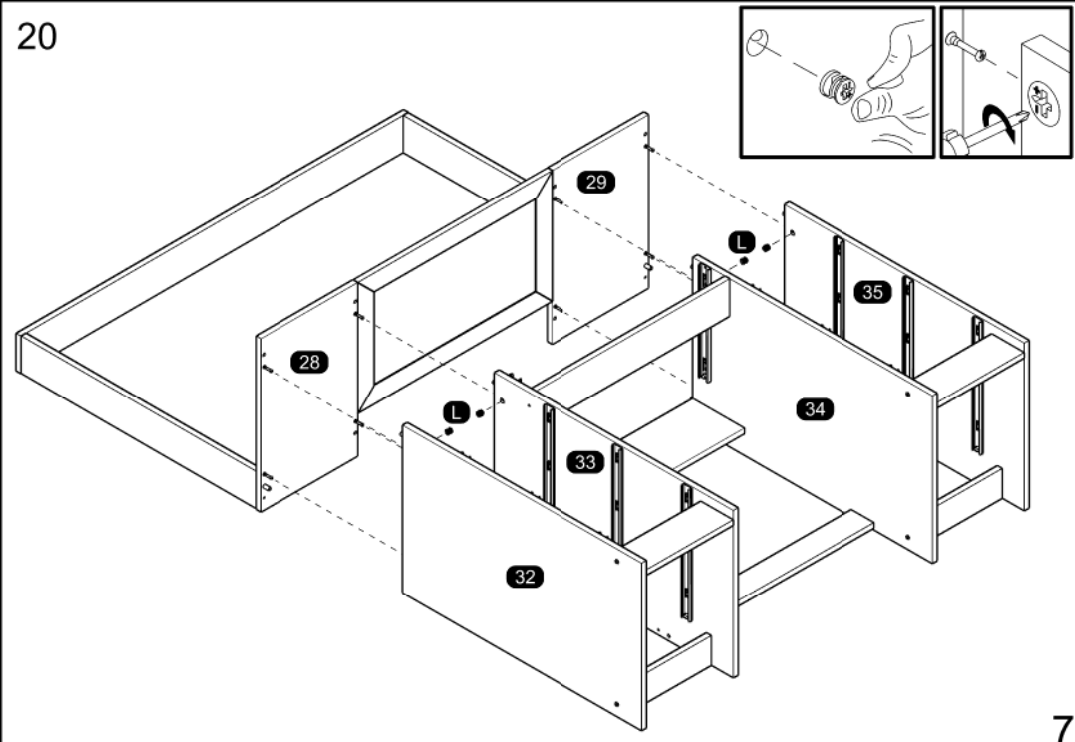

21

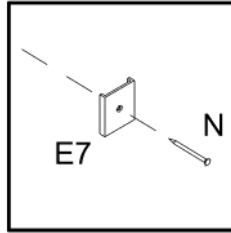
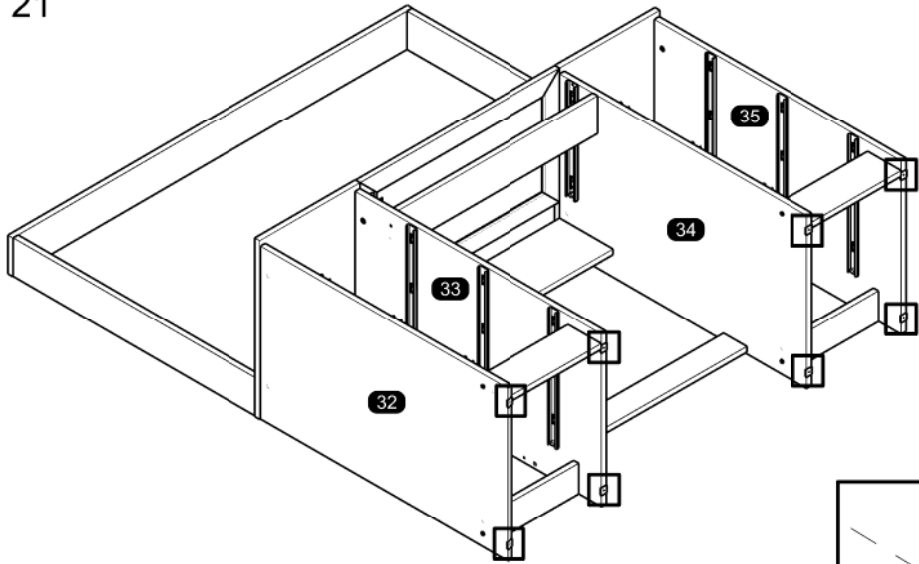

23

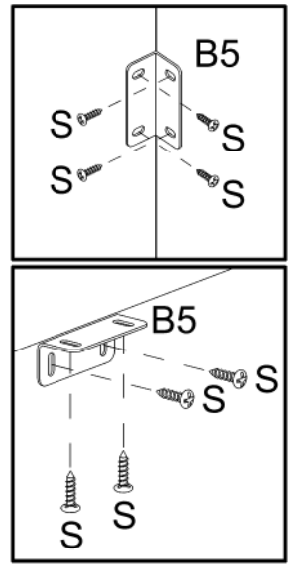
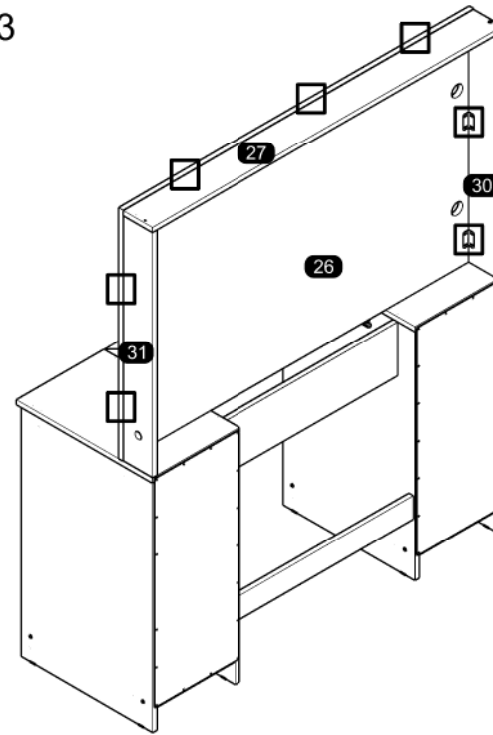

22

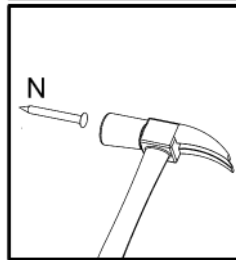
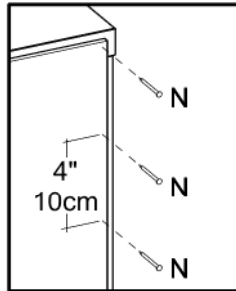
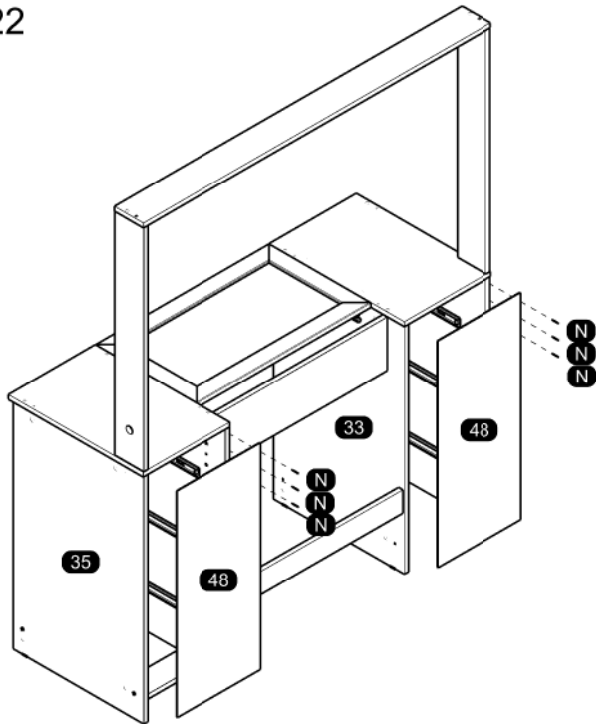

24

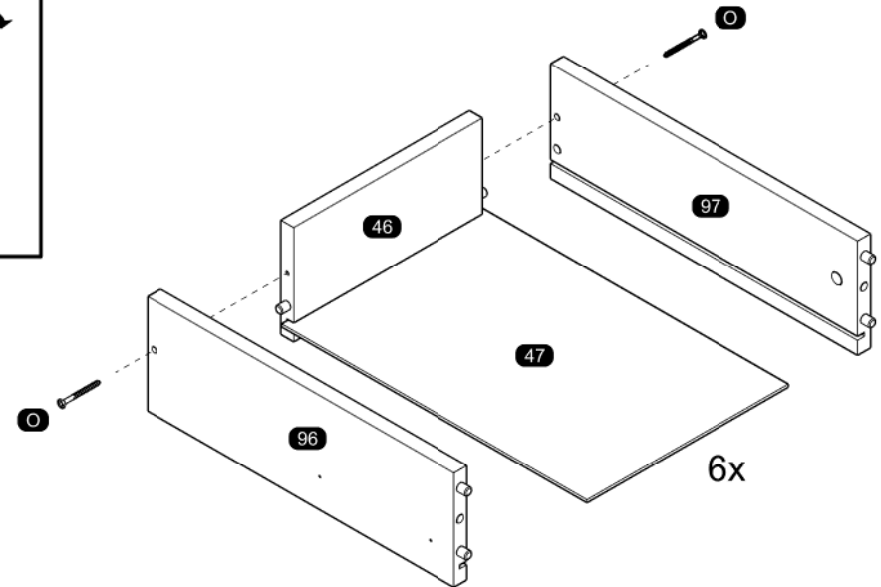
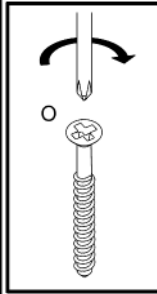

25

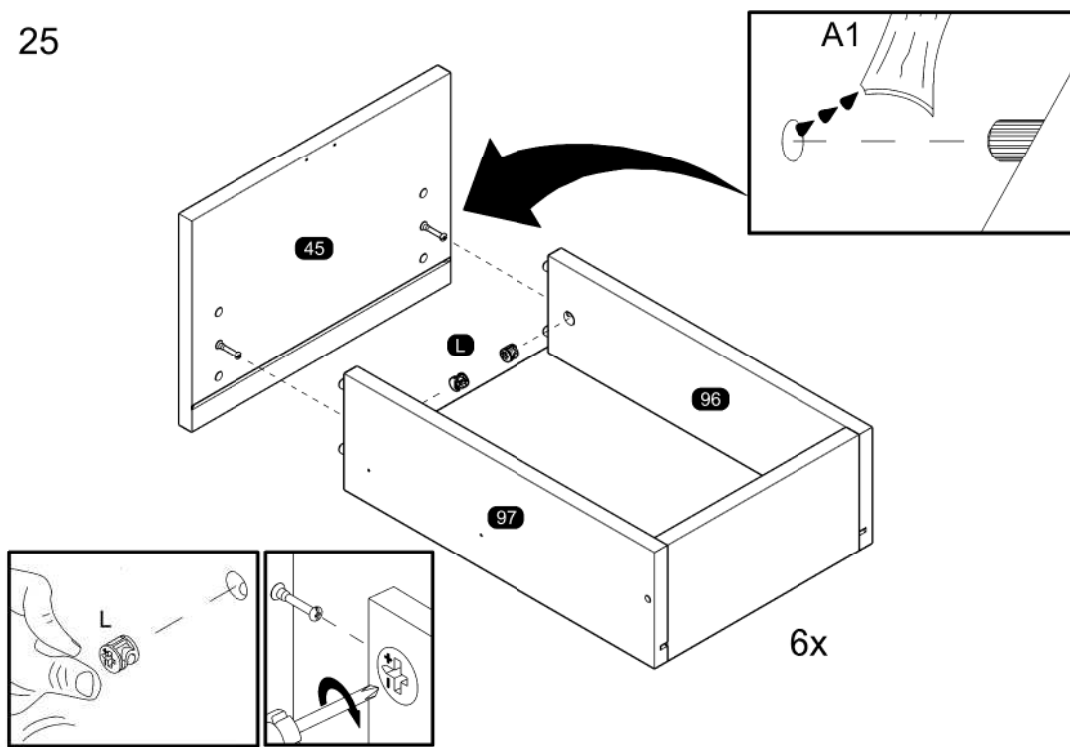

27

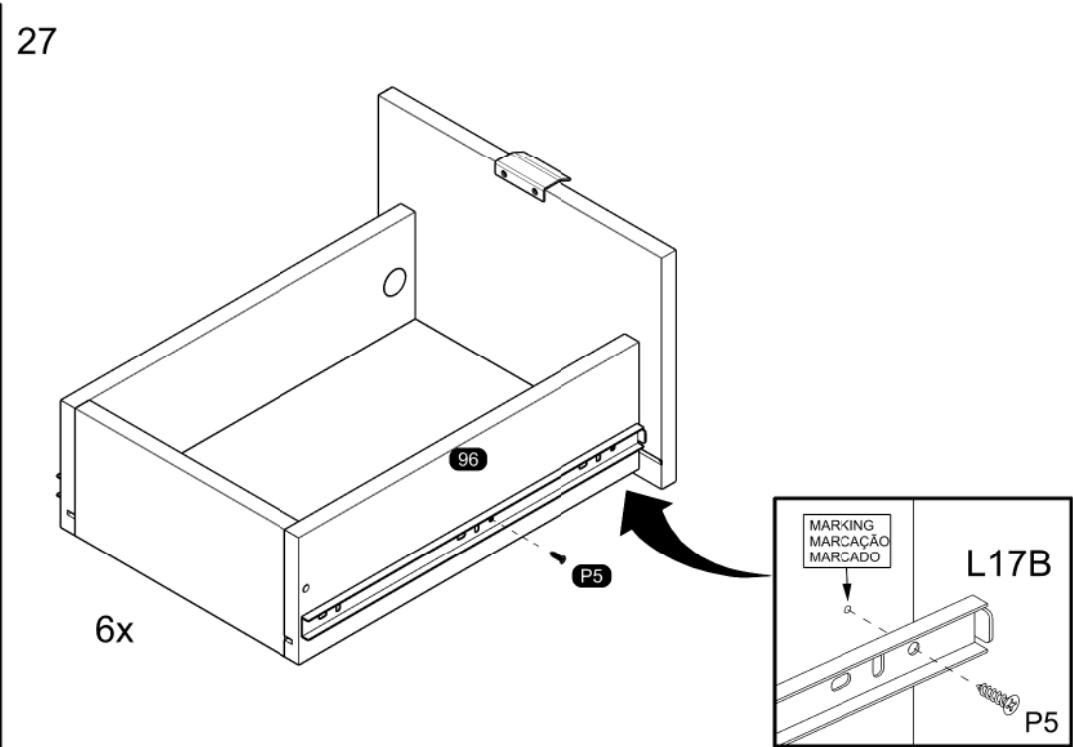

26

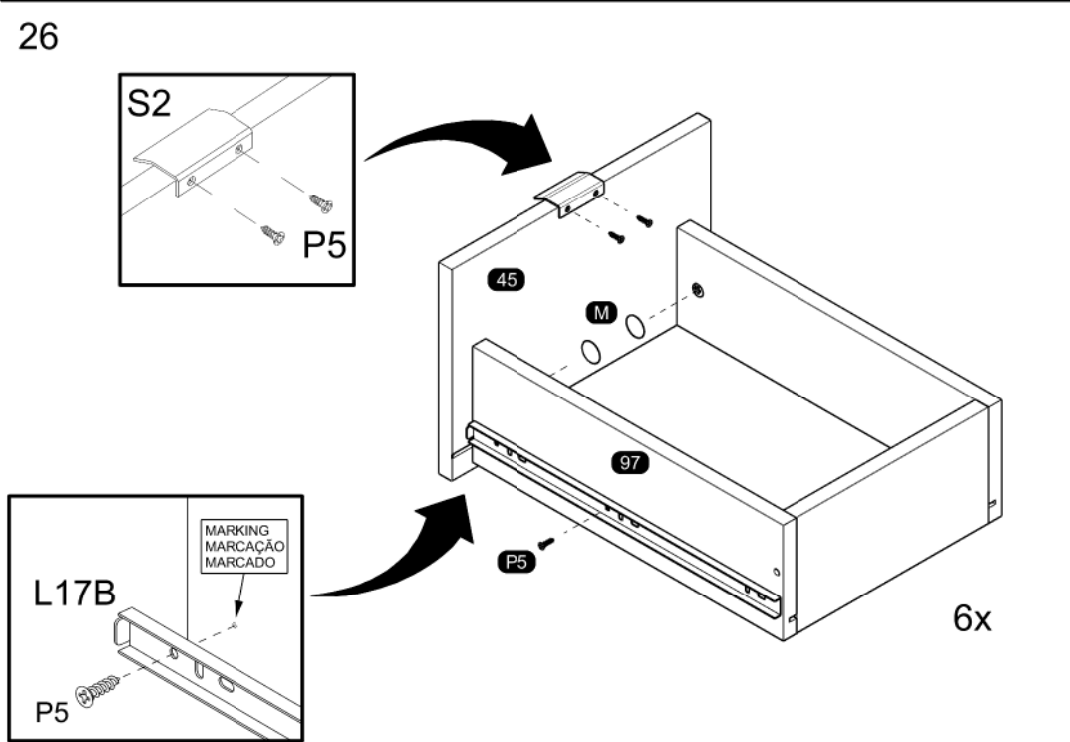

28

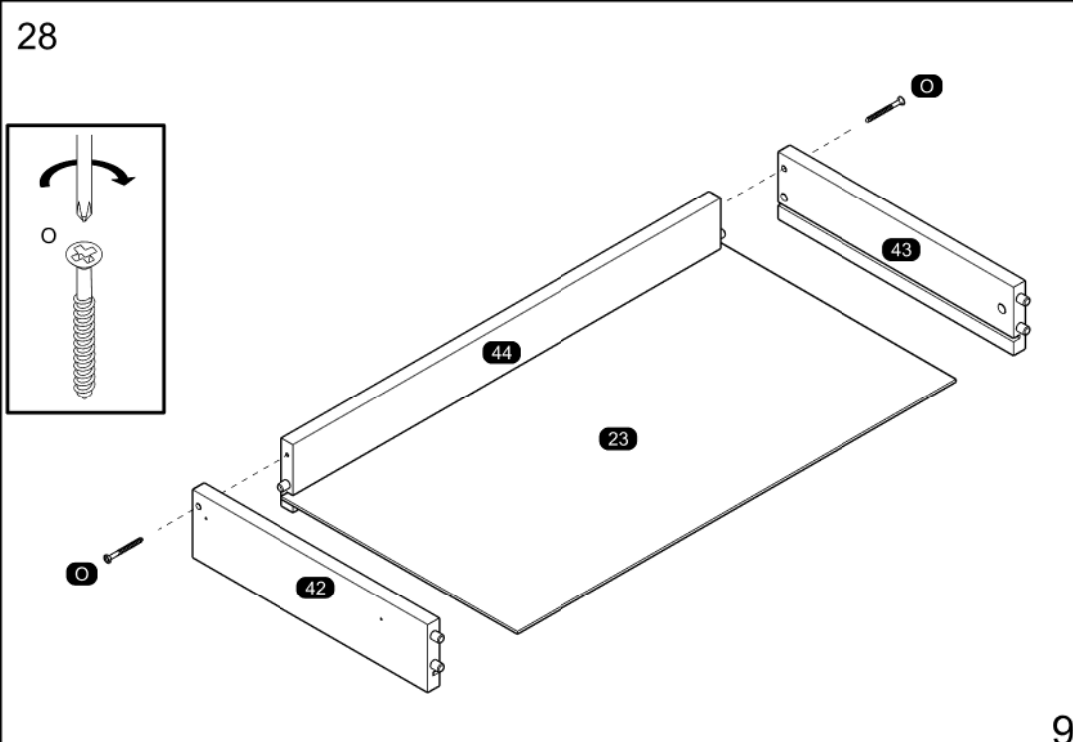

29

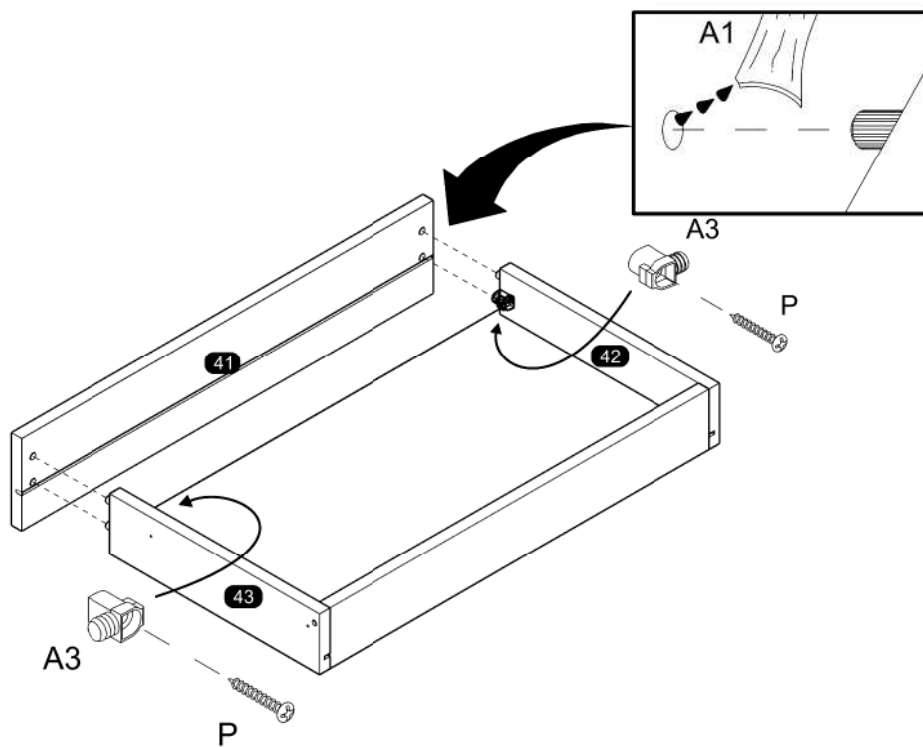

31

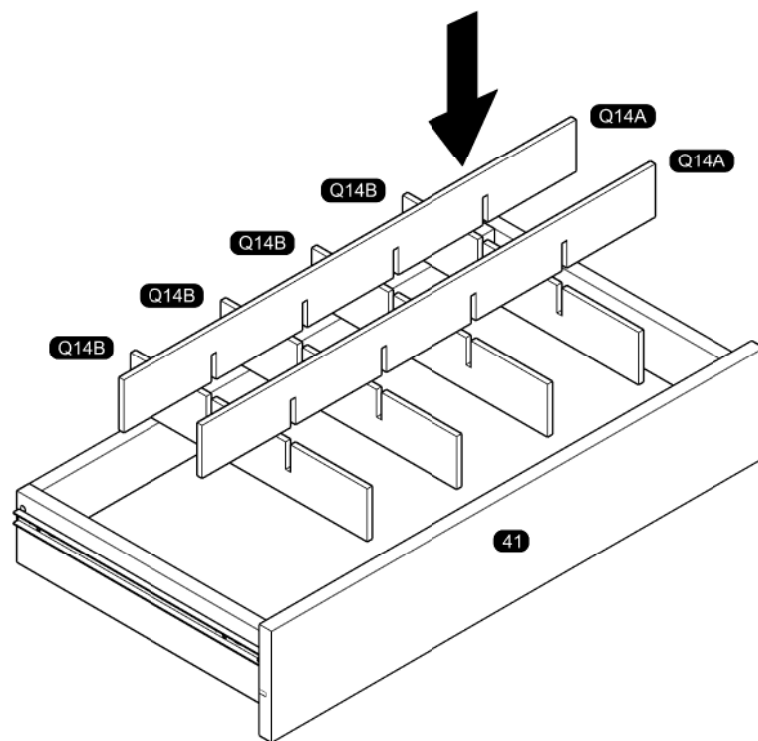

30

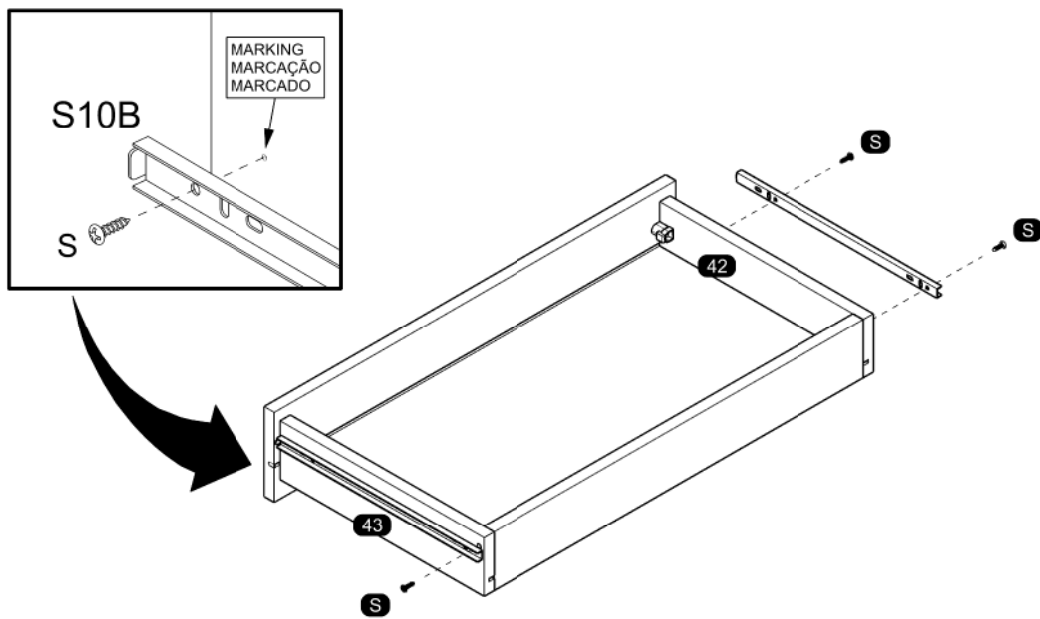

32

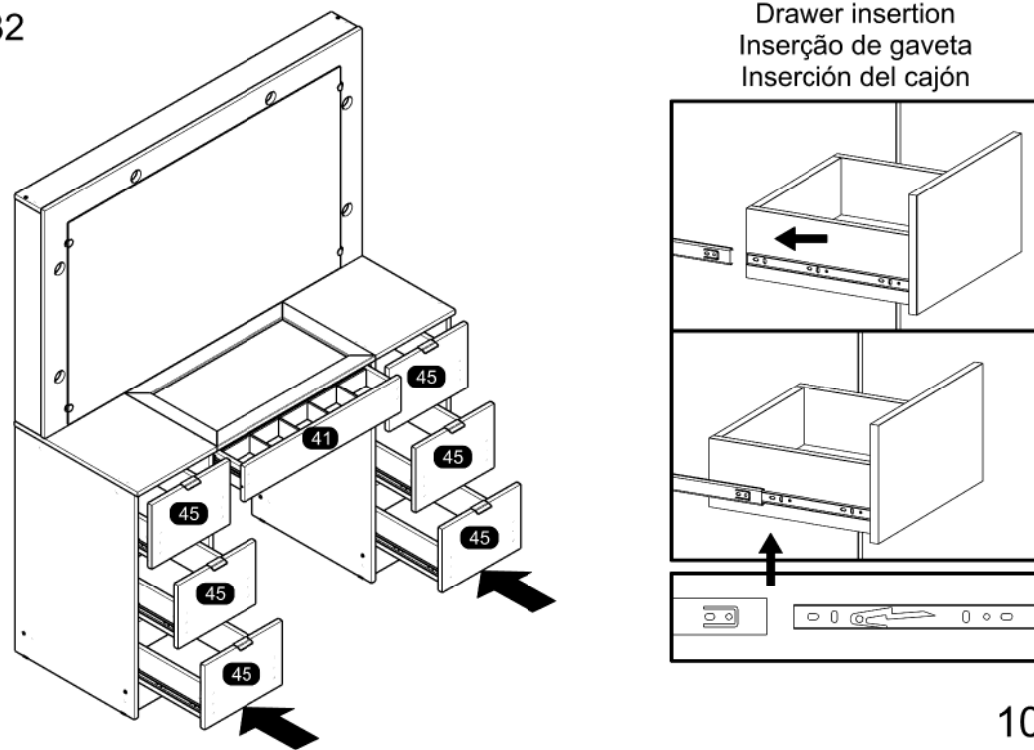

10

33

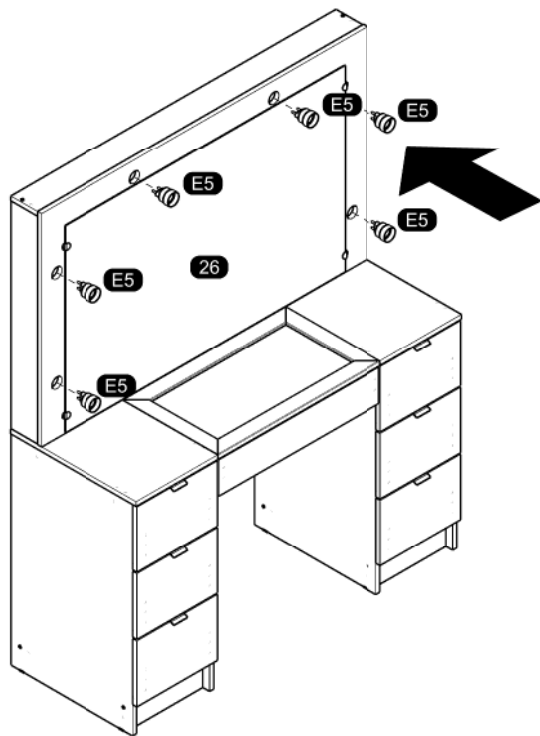

35

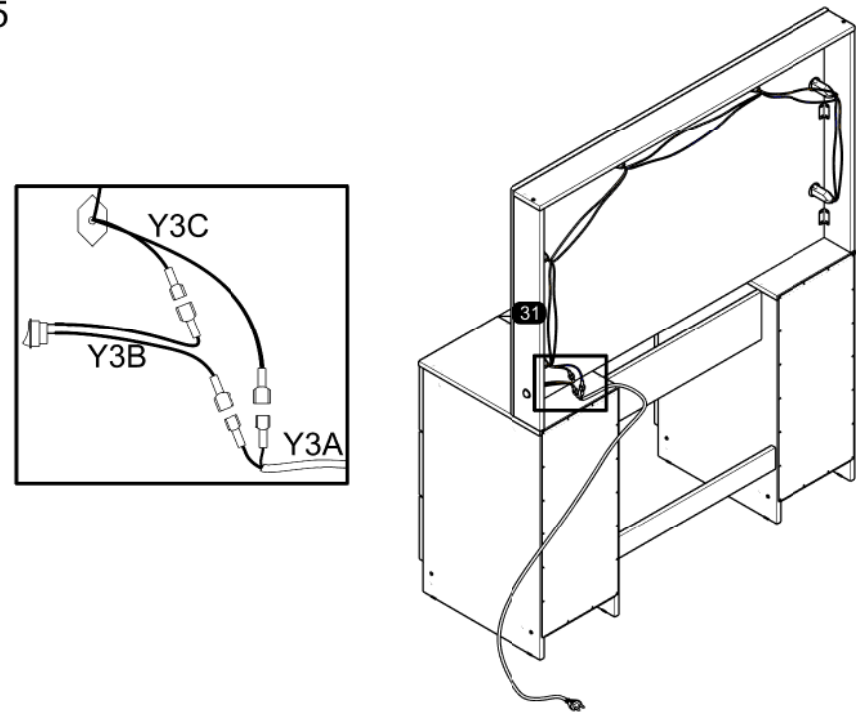

34

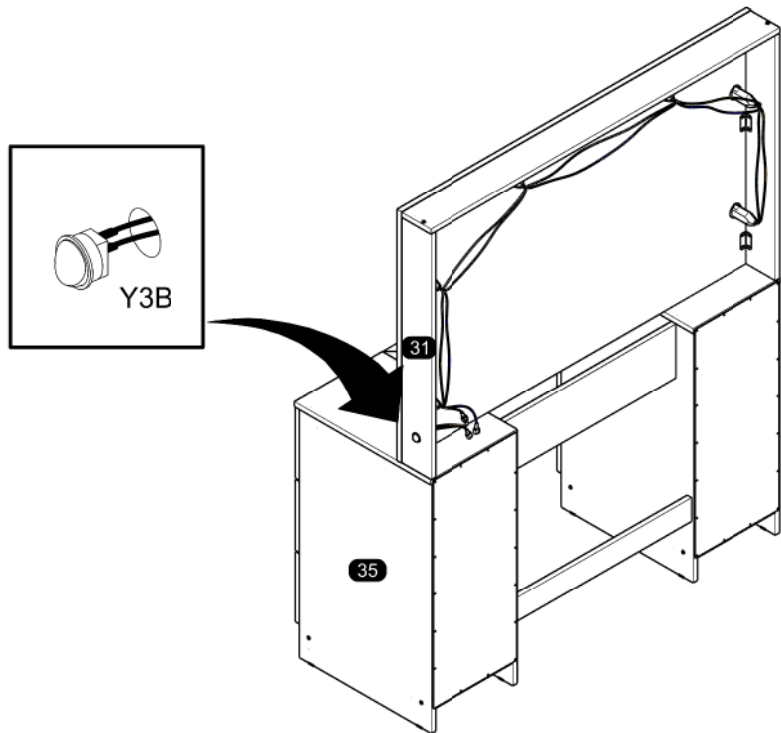

36

