



O930-64 KIT ESPELHO 1050x350x3 COM 2 UNIDADES

Esse Kit Espelho é opcional e é vendido separadamente.

Este juego de espejos es opcional y se vende por separado.

This Mirror Kit is optional and sold separately.

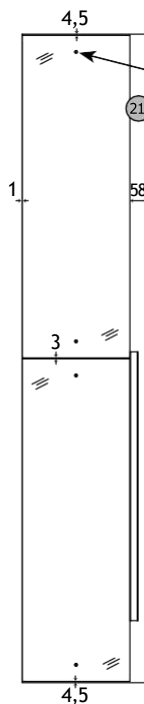

ITM/D325-
REV- 007

Fixar o Espelho com a Bucha e o Parafuso, que acompanha o kit.

Arreglar el espejo con el Casquillo y Tornillo, que viene con el kit.

Attach the Mirror with the Bushing and Screw, which accompanies the kit.

Utilizar a parafusadeira com o torque 3.

Utilice el destornillador con torque 3.

Use the screwdriver with torque 3.

Medidas em mm

Medidas en mm

Measurements in mm

Produto Concluído Producto terminado Finished Product

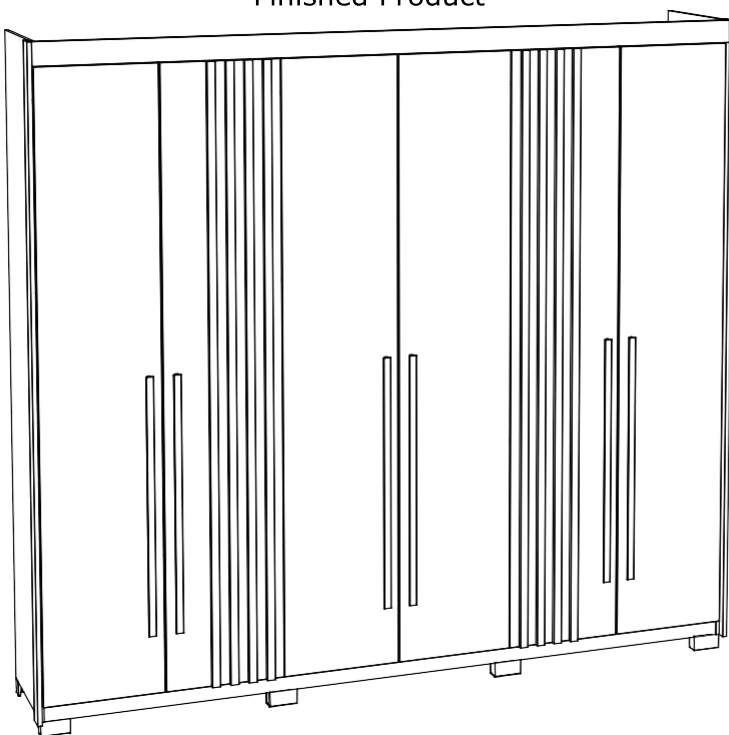

HENN

Ind. e Com. de Móveis Henn
Mondai - SC - Brasil

+55 49 3674.3500

@moveishenn
www.henn.com.br

ITM/D325- INSTRUÇÕES DE MONTAGEM

INSTRUCCIONES DE MONTAJE
ASSEMBLY INSTRUCTIONS

Roupeiro Norton 6 Portas 4 Gavetas | Armario Norton 6 Puertas 4 Cajones | Wardrobe Norton 6 Doors 4 Drawers

D325-127 Nature/Off White

D325-128 Nature

D325-222 Nature/Avelã

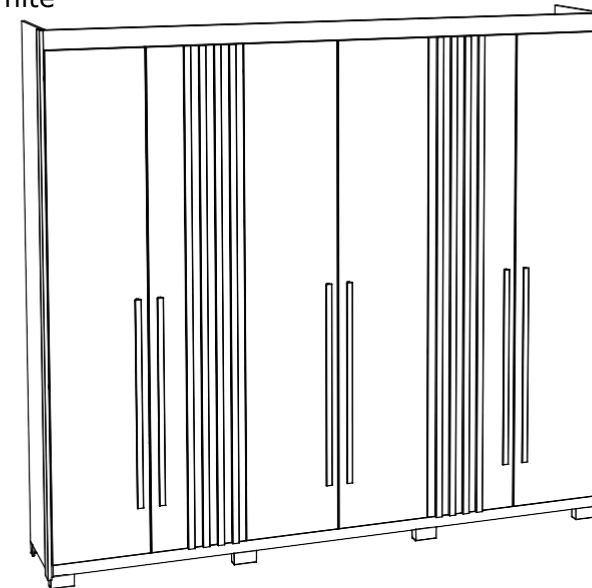

Requisitos para montagem Requisitos para la montaje Assembly Requirements

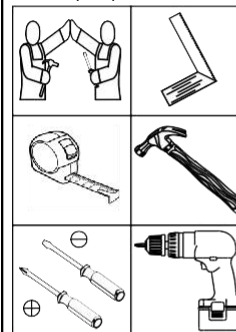

Imagens meramente ilustrativas, não acompanha o produto.
Imágenes ilustrativas, no incluidas con el producto.
Illustrative images, not included with the product.

AVISO

Para limpeza de seu móvel, use uma flanela seca ou umedecida, e não utilize produtos químicos que possam danificar seu produto.

SISTEMA DE MONTAGEM

O sistema de montagem dos produtos, funciona de acordo com a ordem crescente dos números indicados no desenho. Ex: 01, 02, 03, 04... até a conclusão da montagem.

ASSISTÊNCIA TÉCNICA

Para solicitação de Assistência Técnica você consumidor deverá entrar em contato com o Lojista a qual você realizou a compra deste produto e solicitar a assistência técnica das peças avariadas. A garantia abrange todas as peças, partes e componentes que eventualmente venham apresentar defeito de fabricação no prazo de 03 (três) meses, contando a partir da entrega do produto ao consumidor, mediante nota fiscal de compra. Se houver qualquer alteração na estrutura do produto ou ocorrer defeito por negligência do montador/consumidor em relação a instrução de montagem e manuseio, não será fornecido assistência técnica gratuita.

ADVERTENCIA

Para limpeza de su móvil, use una franela seca o húmeda, y no utilice productos químicos que puedan dañar su producto.

SISTEMA DE MONTAJE

El sistema de montaje de los productos funciona de acuerdo con el orden creciente de los números indicados en el dibujo. Ei.: 01, 02, 03, 04... hasta la conclusión del montaje.

ASISTENCIA TÉCNICA

Para solicitar Asistencia Técnica, el consumidor debe comunicarse con el Comercio que usted realizó la compra de este producto y solicita asistencia técnica para las partes dañadas. La garantía cubre todas las partes, piezas y componentes que eventualmente puedan presentar defecto de fabricación en el plazo de 03 (tres) meses, contados a partir de la entrega del producto al consumidor, mediante factura de compra. Si se produce algún cambio en la estructura del producto o se produce un defecto por negligencia del montador/consumidor en relación con las instrucciones de montaje y manipulación, no se prestará asistencia técnica gratuita.

NOTICE

To clean your furniture, use a dry or wet cloth, and do not use chemicals that may damage your product.













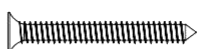











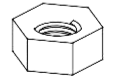
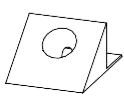

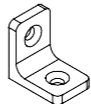
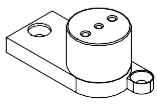
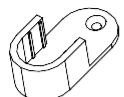
ASSEMBLY SYSTEM

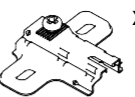
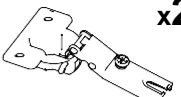
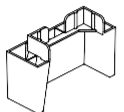
The products' assembly system works according to the increasing order of the indicated numbers. For example: 01, 02, 03, 04 ... to the end of the assembly.

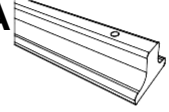
TECHNICAL ASSISTANCE





To request Technical Assistance, the consumer must contact the retailer from whom you purchased this product and request technical assistance for the damaged parts. The warranty covers all parts, parts and components that may eventually present a manufacturing defect within a period of 03 (three) months, counting from the delivery of the product to the consumer, by means of a purchase invoice. If there is any change in the structure of the product or defect occurs due to negligence of the assembler/consumer in relation to the assembly and handling instruction, free technical assistance will not be provided.

ACESSÓRIOS | ACCESORIOS | ACCESSORIES

A x8  Parafuso 4,5x50mm CHT.	B x29  Parafuso 3,5x40mm CHT.	C x8  Parafuso 4,0x35mm CHT.	D x18  Parafuso 3,5x25mm FLA.
E x16  Parafuso 4,0x25mm MET FLA.	F x54  Parafuso 4,0x25mm CHT	G x8  Parafuso 3,0x16mm CHT.	H x1  Etiqueta Resinada Henn
I x192  Parafuso 3,5x12mm CHT.	J x88  Cavilha Plástica 5x25mm	K x2  Parafuso Minifix	L x2  Tambor Minifix
M x179  Prego 10x10mm	N x46  Fixador de Fundo	O x8  Prego 12x12mm Anelado	P x16  Porca Sextavada MA4
Q x8  Cantoneira Suporte Triangular	R x8  Porca Cilíndrica	S x18  Cantoneira Plástica 20x20mm	T x8  Distanciador Plástico da Correção
U x4  Suporte Cabideiro Oblongo	V x2  Cantoneira de Fixação Zamac	W x24  Calço Metal 5mm	X x24  Dobradiça 26mm Colo Alto
Y x8  Pé "U" 50x40x100mm	Z x4 PAR  Correção Telescópica 300x30mm	AA x6  Puxador Pux. Rev. MDF 875	AB x2  Cabideiro Alumínio Obl. 805mm estriado
AC x3  Perfi I "H" 1673mm	AD x74  Adesivo Tapa Parafuso 10mm	AE x4  Adesivo Tapa Parafuso 17mm	AF x2  Giz de Correção
AG x2  Sachê de Cola			

PASSO 16

ACESSÓRIOS REQUERIDOS

H		01
AD		74
AE		04
AF		02

Pesos máximos recomendados com carga distribuída
Peso máximo recomendado con la carga distribuida
Recommended maximum weight with distributed load.

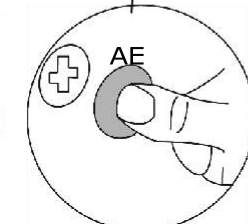
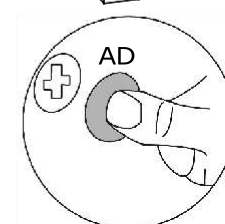
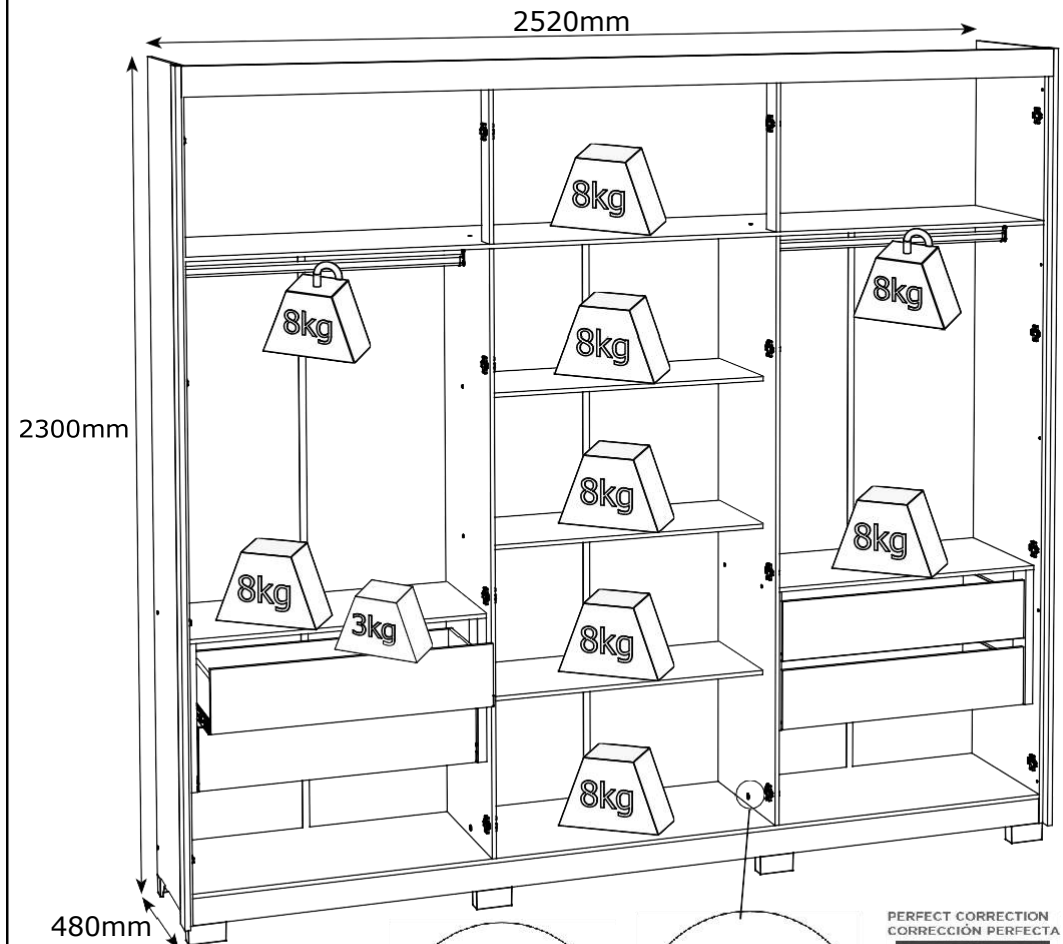

PERFECT CORRECTION
CORRECCIÓN PERFECTA

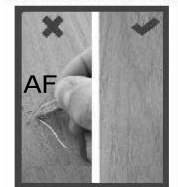

PEÇAS REQUERIDAS

ACESSORIOS REQUERIDOS

FERRAMENTAS NECESSARIAS

27	RIPA DE TRÁS	x4
----	--------------	----

G		08
I		24
O		08
Q		08
Z		04
AG		

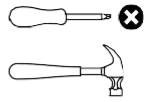

4x

3º

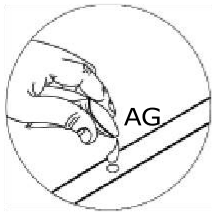
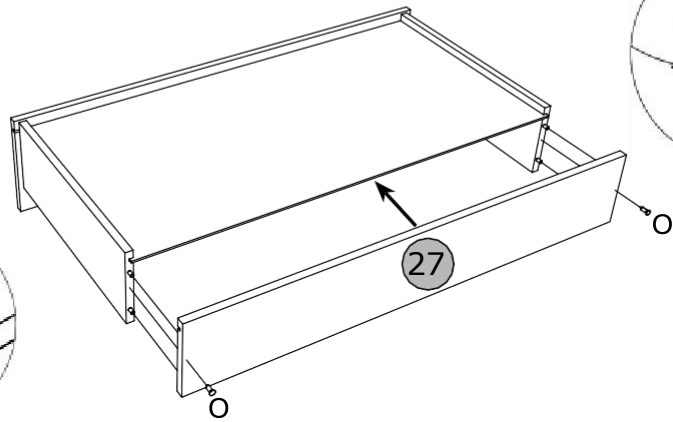

4x

4º

Deixar 3mm de distância da frente de gaveta.

Deje una separación de 3mm del frente del cajón.

Leave 3mm away from the front of the drawer.

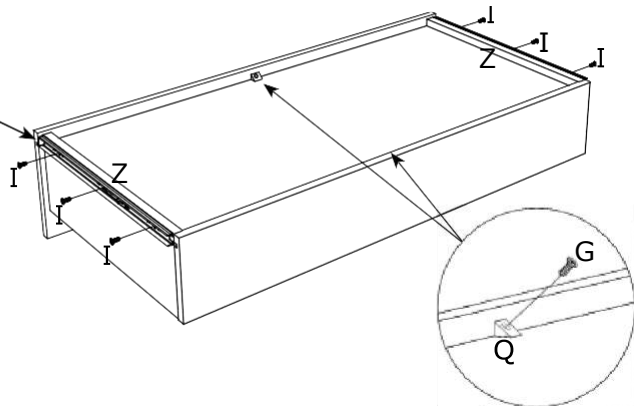

PARAFUSOS EM ESCALA 1:1 | TORNILLOS A ESCALA 1:1 | 1:1 SCALE SCREWS

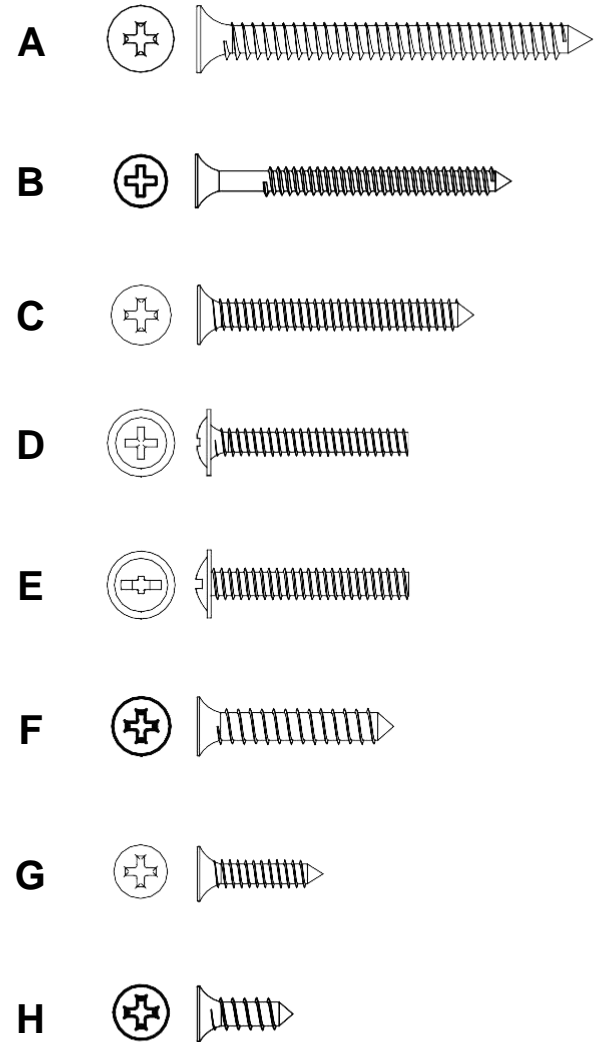

Item	Caixa Caja Box	Qty Ctd Qty	Descrição Descripción Description	Dimensões (mm) Dimensiones (mm) Dimensions (mm)		
				Comprimento Largo Length	Largura Ancho Width	Espessura Grosor Thickness
1	2/3	1	RODAPÉ FRONTAL FALDÓN DELANTERO FRONT SKIRTING	2463	73	12
2	1/3	2	TRAVESSA DO RODAPÉ PLACA DE RODAPIÉ SKIRTING PLATE	415	73	12
3	2/3	1	RODAPÉ TRASEIRO REPOSAPIÉS TRASERO BACK FOOTBOARD	2463	73	12
4	2/3	1	BASE BASE BASE	2463	445	12
5	1/3	1	LATERAL ESQUERDA LATERAL IZQUIERDA LEFT SIDE	2250	445	12
6	1/3	1	DIVISÃO ESQUERDA DIVISIÓN IZQUIERDA LEFT DIVISION	1659	445	12
7=13	1/3	1	TAMPO DAS GAVETAS TAPA DE LOS CAJONES TOP OF DRAWERS	813	400	12
8	1/3	1	DIVISÃO DIREITA DIVISIÓN DERECHA RIGHT DIVISION	1659	445	12
9	1/3	3	PRATELEIRA ESTANTE SHELF	813	350	12
10	2/3	1	CHÃO DO MALEIRO REPISA SUPERIOR FLOOR OF MALEIRO	2463	445	12
11	1/3	2	RIPA DO MALEIRO TRAVESAÑO SUPERIOR MALEIRO'S LATH	414	73	12
12	1/3	1	LATERAL DIREITA LADO DERECHO RIGHT SIDE	2250	445	12
13=7	1/3	1	TAMPO DAS GAVETAS TAPA DE LOS CAJONES TOP OF DRAWERS	813	400	12
14	2/3	1	TAMPO SUPERIOR TAPA SUPERIOR TOP PANEL	2463	445	12
15	2/3	1	MOLDURA TRASEIRA MARCO TRASERO REAR FRAME	2486	28	15
16	2/3	2	MOLDURA LATERAL MARCO LATERAL LATERAL FRAME	2250	60	15
17	1/3	4	RIPA LATERAL CINTA LATERAL SIDE RIBBON	395	80	25
18	2/3	1	MOLDURA SUPERIOR MARCO SUPERIOR TOP FRAME	2486	80	15
19	2/3	1	FUNDO SUPERIOR FONDO TOP TOP FUND	2483	431	3
20	2/3	6	FUNDO FONDO BOTTOM	1675	410	3
21	3/3	4	PORTA PUERTA DOOR	2112	409	15
22	3/3	2	PORTA COM APLIQUE PUERTA CON APLICARSE DOOR WITH APPLY	2112	409	15
23	2/3	8	APLIQUE APLICARSE APLLY	2112	28	15
24	1/3	4	FRENTE DE GAVETA FRENTE DE CAJÓN FRONT OF DRAWER	755	170	12
25	2/3	8	LADO DE GAVETA LADO DEL CAJÓN SIDE OF DRAWER	350	122	12
26	1/3	4	FUNDO DE GAVETA RECORTADO FONDO DEL CAJÓN RECORTADO CROPPED DRAWER BOTTOM	725	361	3
27	1/3	4	RIPA DE TRÁS MALLA DETRÁS REAR LATH	738	122	12

PEÇAS REQUERIDAS			ACESSÓRIOS REQUERIDOS			FERRAMENTAS NECESSARIAS
25	LADO DE GAVETA	x8	J		32	
			AG			

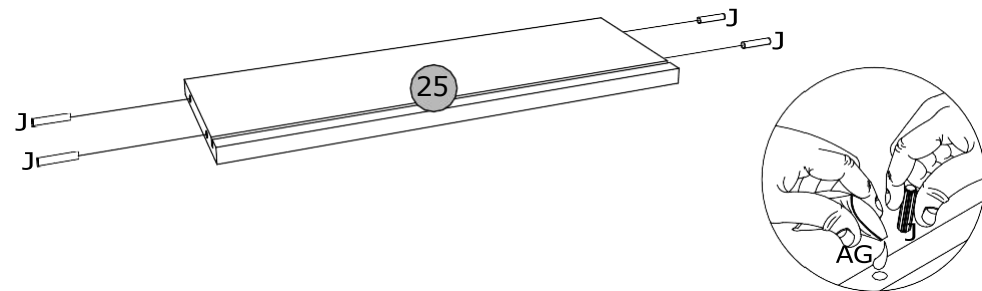

PEÇAS REQUERIDAS			ACESSÓRIOS REQUERIDOS			FERRAMENTAS NECESSARIAS
24	FRENTE DE GAVETA	x4	I		16	
25	LADO DE GAVETA	x8	S		08	
26	FUNDO DE GAVETA RECORTADO	x4	AG			

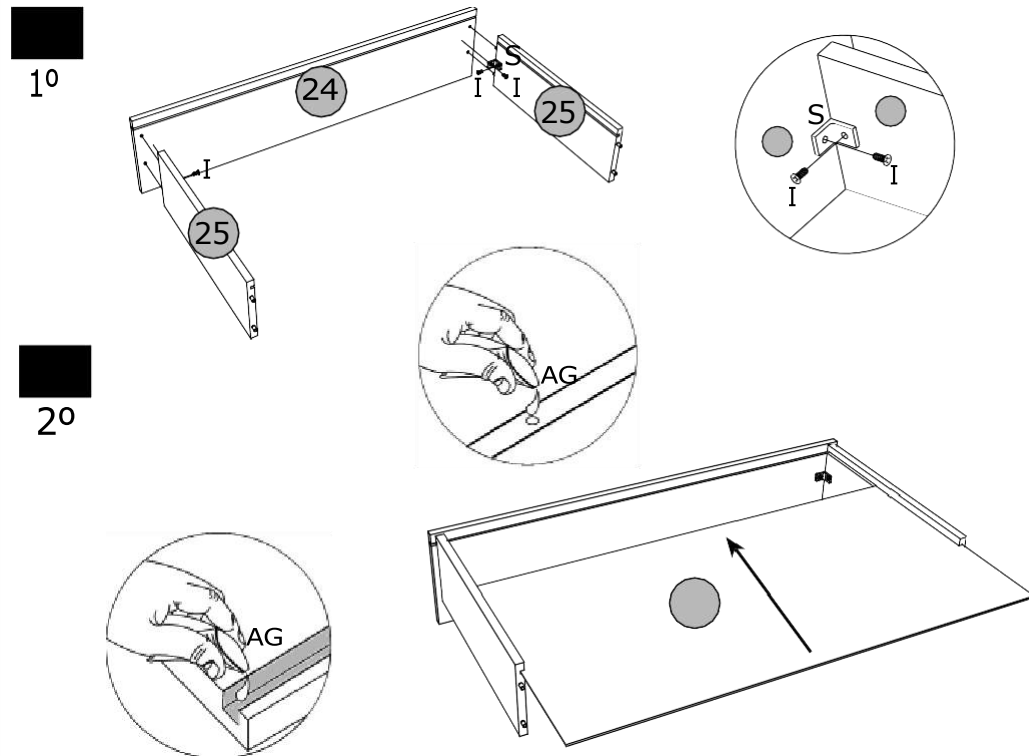

PEÇAS REQUERIDAS

21	PORTA	x4
22	PORTA COM APLIQUE	x2

ACESSORIOS REQUERIDOS

D		18
E		16
I		16
P		16
W		16

FERRAMENTAS NECESSARIAS

X		
Z		04
AA		06
AB		02

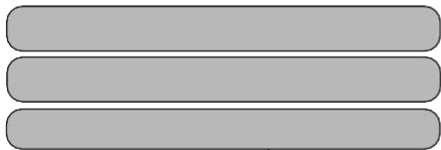
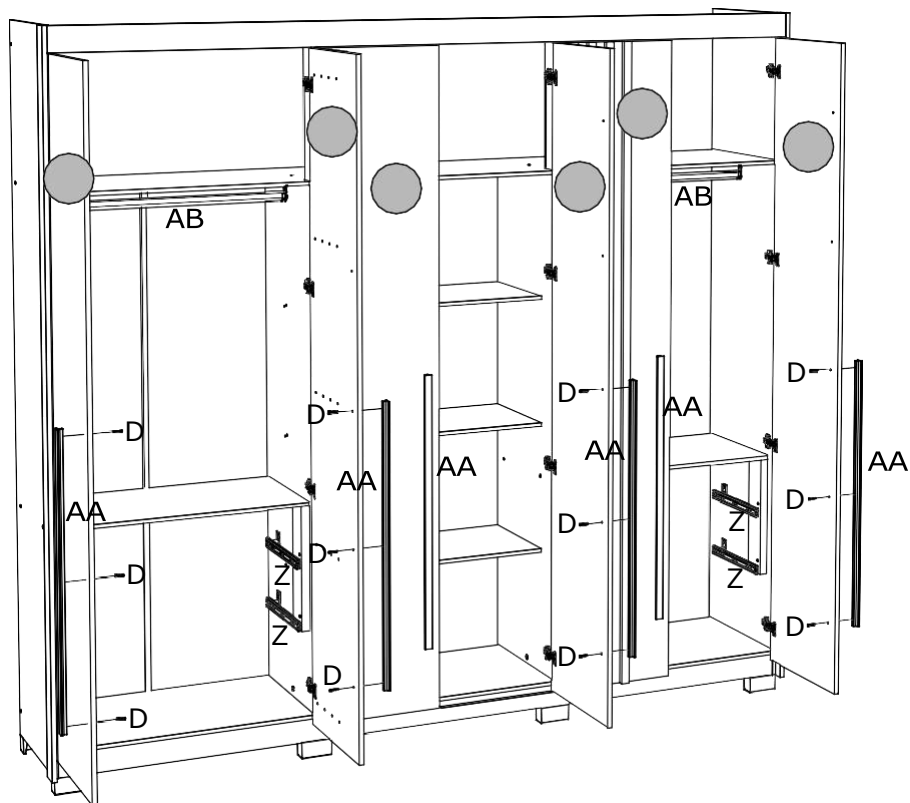

Fixar as correias nessas furações
 Fijar las diapositivas de estos agujeros
 Fix the slides in these holes

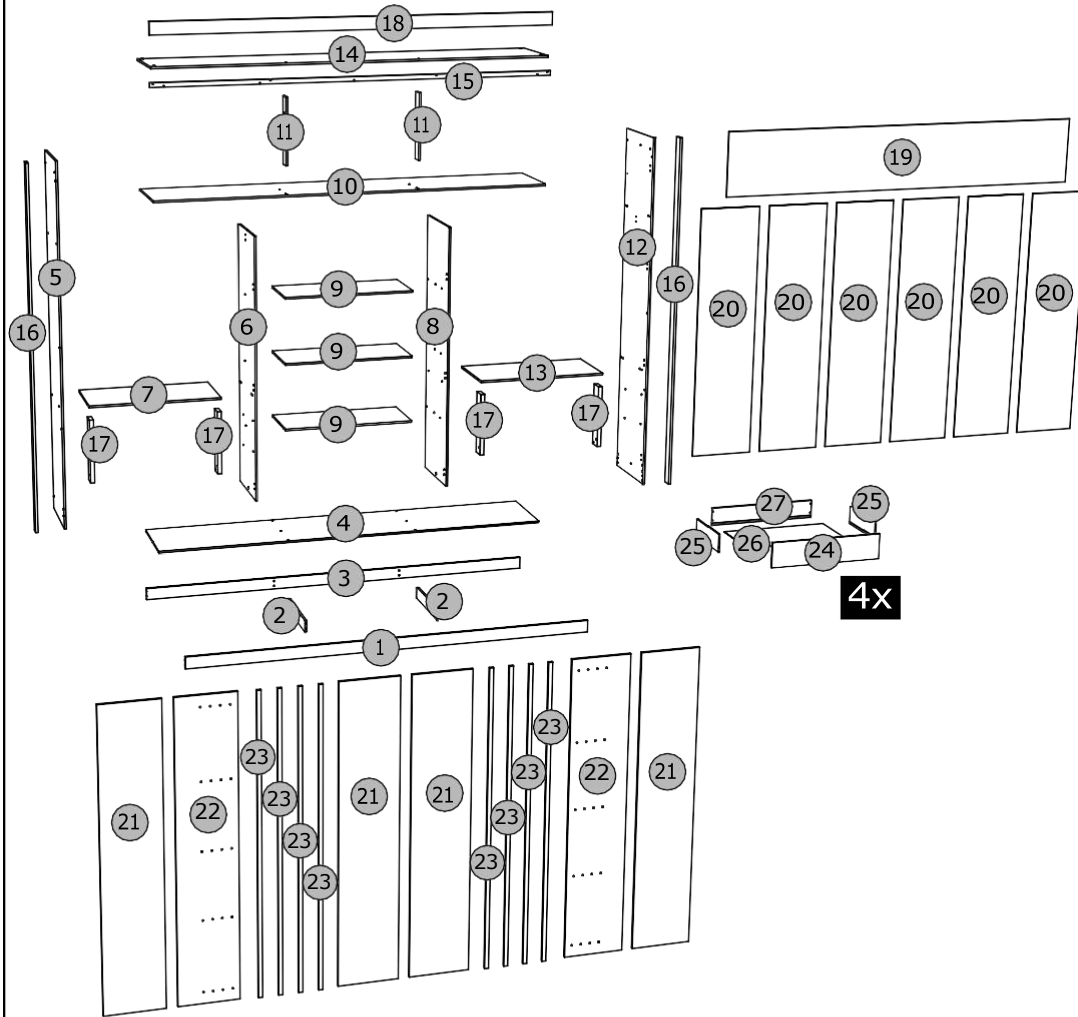
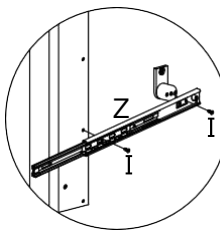
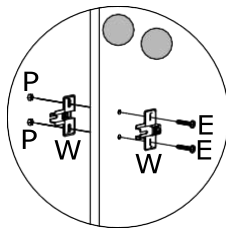
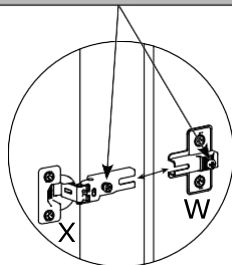
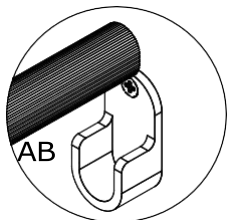

4x

PASSO 1

ITM/D325-

PEÇAS REQUERIDAS

1	RODAPÉ FRONTAL	x1
2	TRAVESSA DO RODAPÉ	x2
3	RODAPÉ TRASEIRO	x1
11	RIPA DO MALEIRO	x2
18	MOLDURA SUPERIOR	x1

ACESSÓRIOS REQUERIDOS

I		06
J		20
S		04
V		02

FERRAMENTAS NECESSARIAS

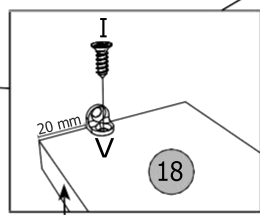
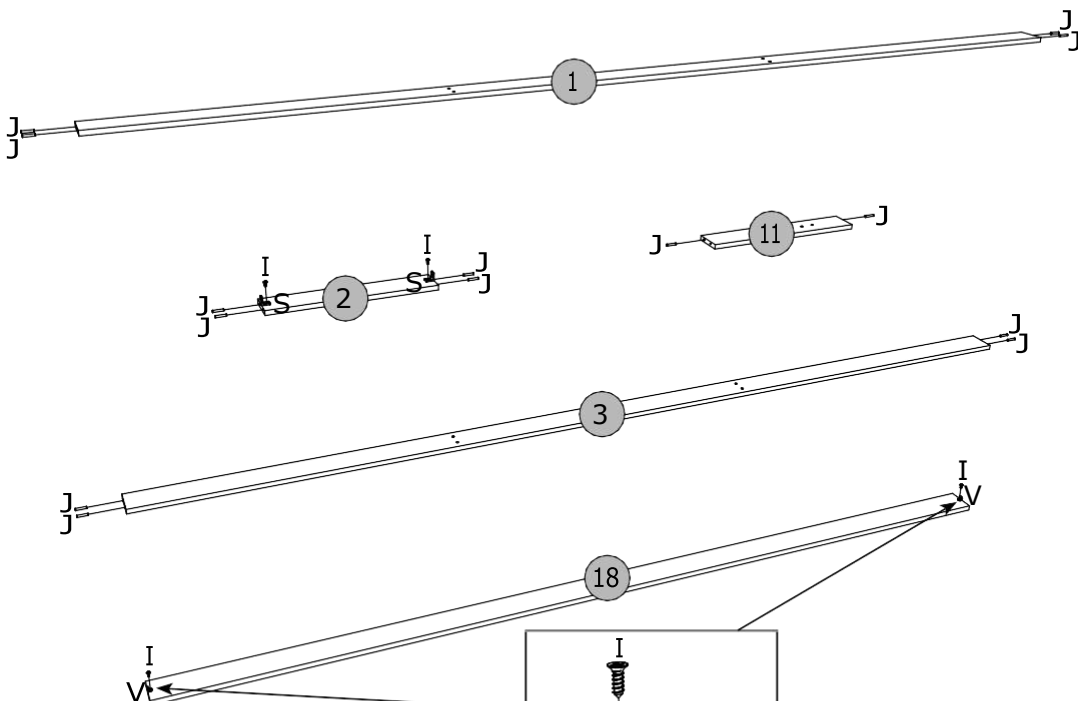
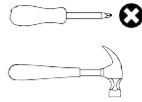

Lado sem borda
Lado sin borde
Side without border

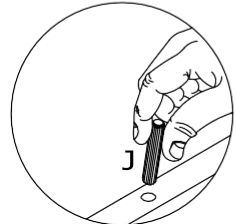
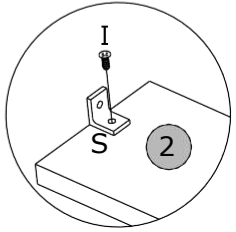

PASSO 10

ITM/D325-

PEÇAS REQUERIDAS

21	PORTA	x4
22	PORTA COM APLIQUE	x2

ACESSÓRIOS REQUERIDOS

H		48
X		24

FERRAMENTAS NECESSARIAS

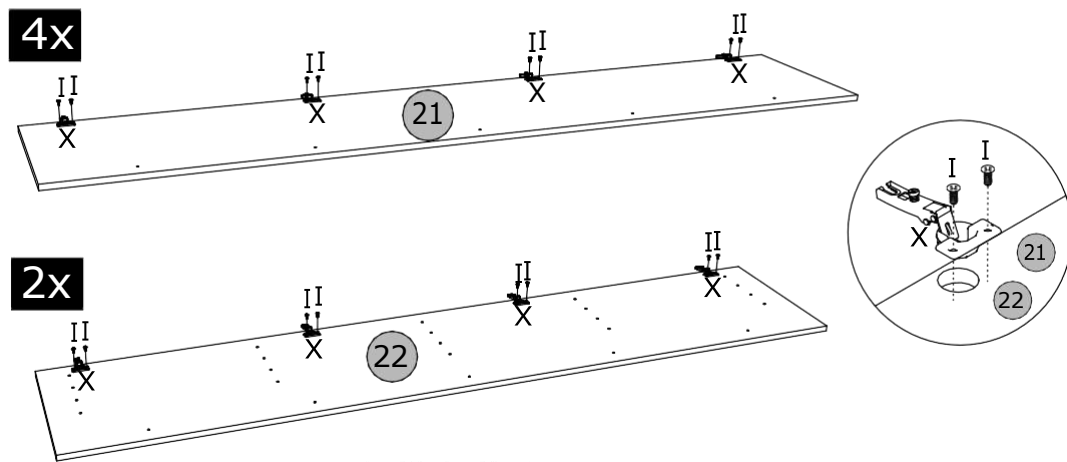

Vídeo: Instalar e regular Dobradiças
Video: Instale y ajuste las bisagras
Video: Install and adjust hinges

PASSO 11

PEÇAS REQUERIDAS

22	PORTA COM APLIQUE	x2
23	APLIQUE	x8

ACESSÓRIOS REQUERIDOS

F		40
---	--	----

FERRAMENTAS NECESSARIAS

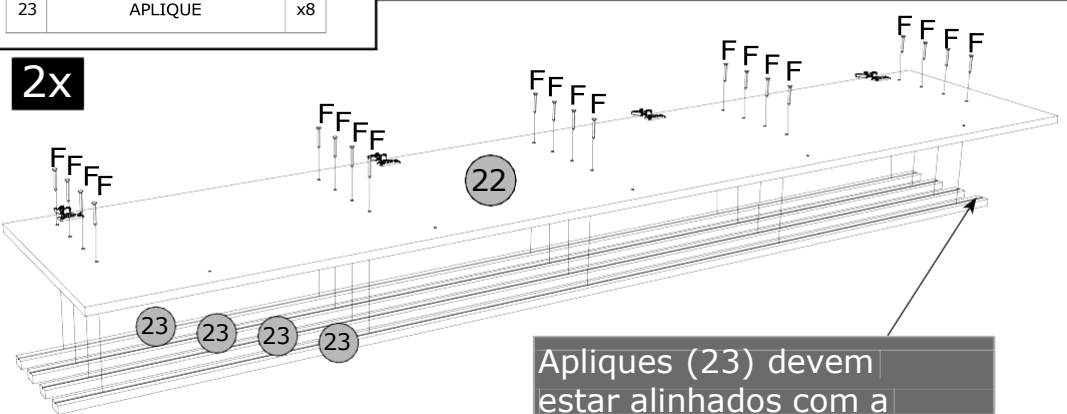

Apliques (23) devem estar alinhados com a Porta (22).
Utilizar o Friso para fixação dos parafusos (F).

PASSO 9

ITM/D325-

PEÇAS REQUERIDAS

18	MOLDURA SUPERIOR	x1
19	FUNDO SUPERIOR	x1
20	FUNDO	x6

ACESSÓRIOS REQUERIDOS

F		04
I		02
M		179
N		46
AC		03

FERRAMENTAS NECESSARIAS

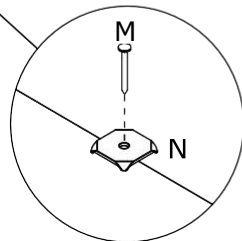
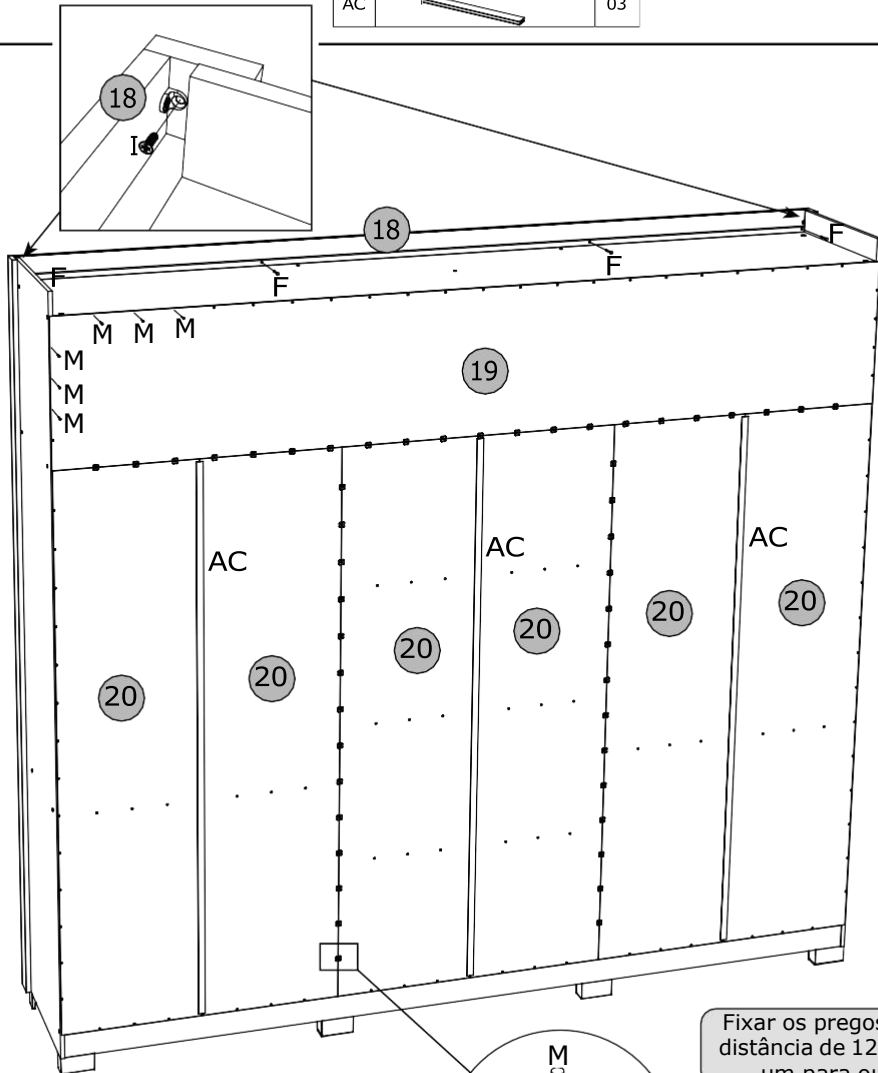
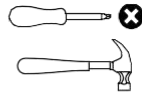

Fixar os pregos a uma distância de 120mm de um para outro.

Fijar las uñas a un distancia de 120mm uno a otro.

Fix the nails at a distance of 120mm from one to the other

PASSO 2

ITM/D325-

PEÇAS REQUERIDAS

4	BASE	x1
7=13	TAMPO DAS GAVETAS	x2
9	PRATELEIRA	x3
10	CHÃO DO MALEIRO	x1
14	TAMPO SUPERIOR	x1

ACESSÓRIOS REQUERIDOS

J		28
K		02
R		08

FERRAMENTAS NECESSARIAS

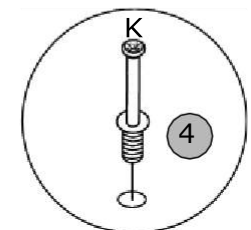
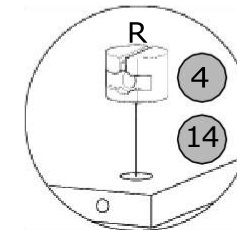
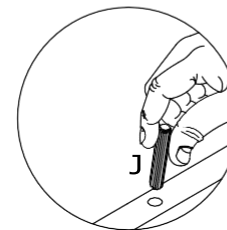
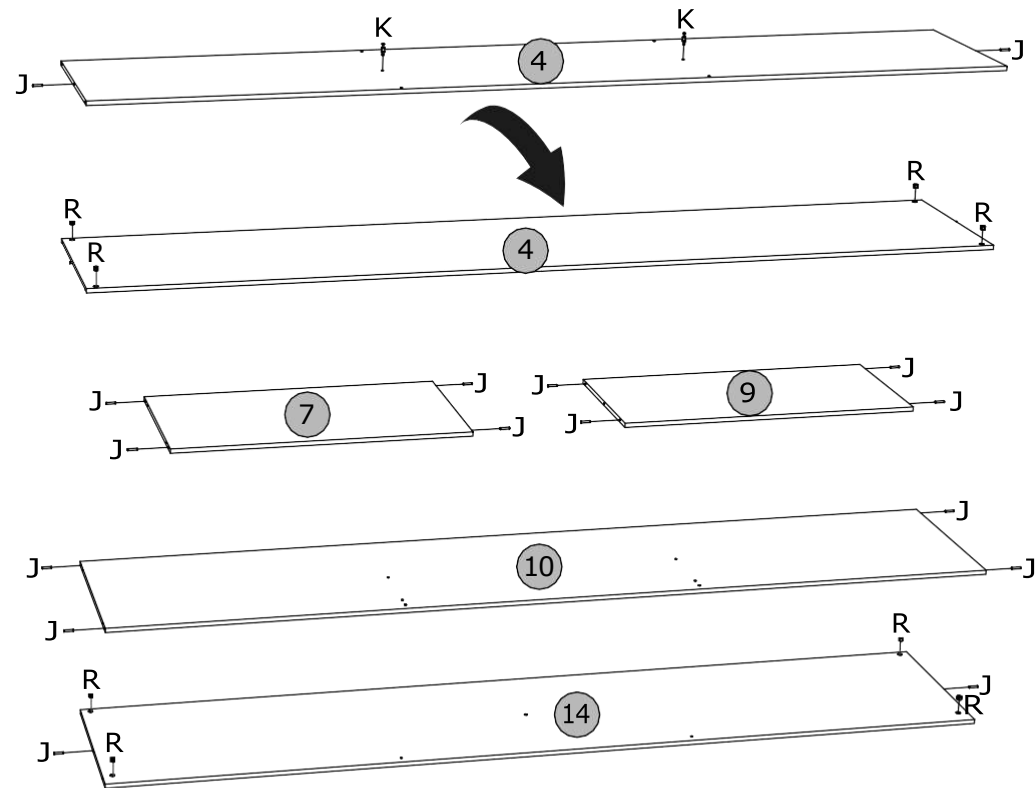
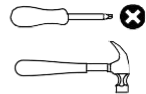

PASSO 3

ITM/D325-

PEÇAS REQUERIDAS

5	LATERAL ESQUERDA	x1
6	DIVISÃO ESQUERDA	x1
8	DIVISÃO DIREITA	x1
12	LATERAL DIREITA	x1

ACESSÓRIOS REQUERIDOS

I		40
J		08
T		08
U		04
W		08

FERRAMENTAS NECESSARIAS

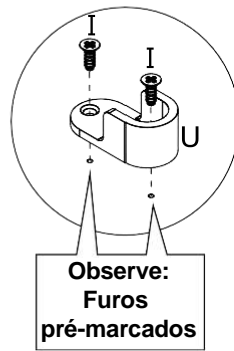
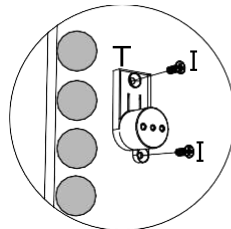
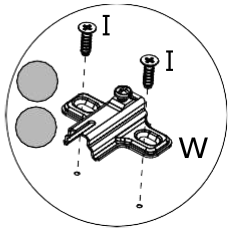
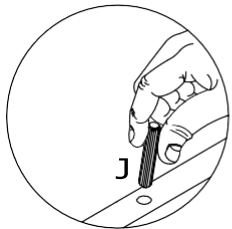
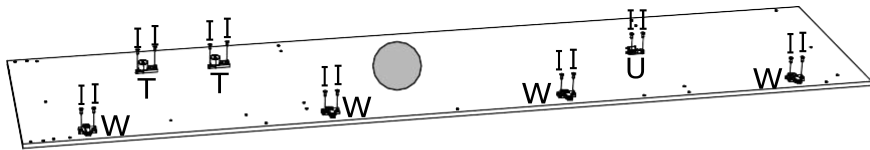
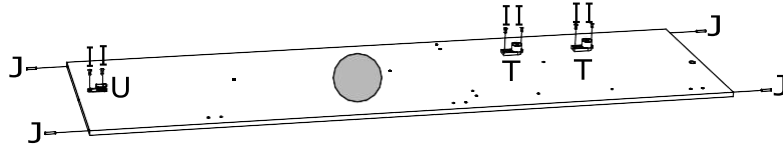
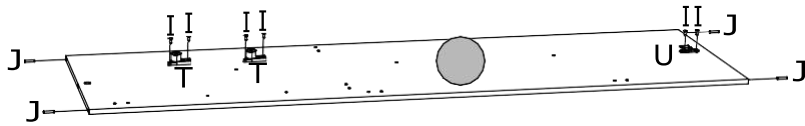
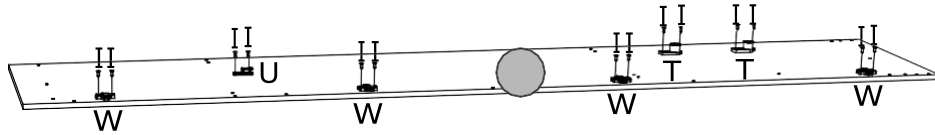
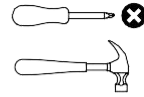

Observe:
Furos
pré-marcados

PASSO 8

ITM/D325-

PEÇAS REQUERIDAS

15	MOLDURA TRASEIRA	x1
16	MOLDURA LATERAL	x2
17	RIPA LATERAL	x4

ACESSÓRIOS REQUERIDOS

B		05
C		08
F		10

FERRAMENTAS NECESSARIAS

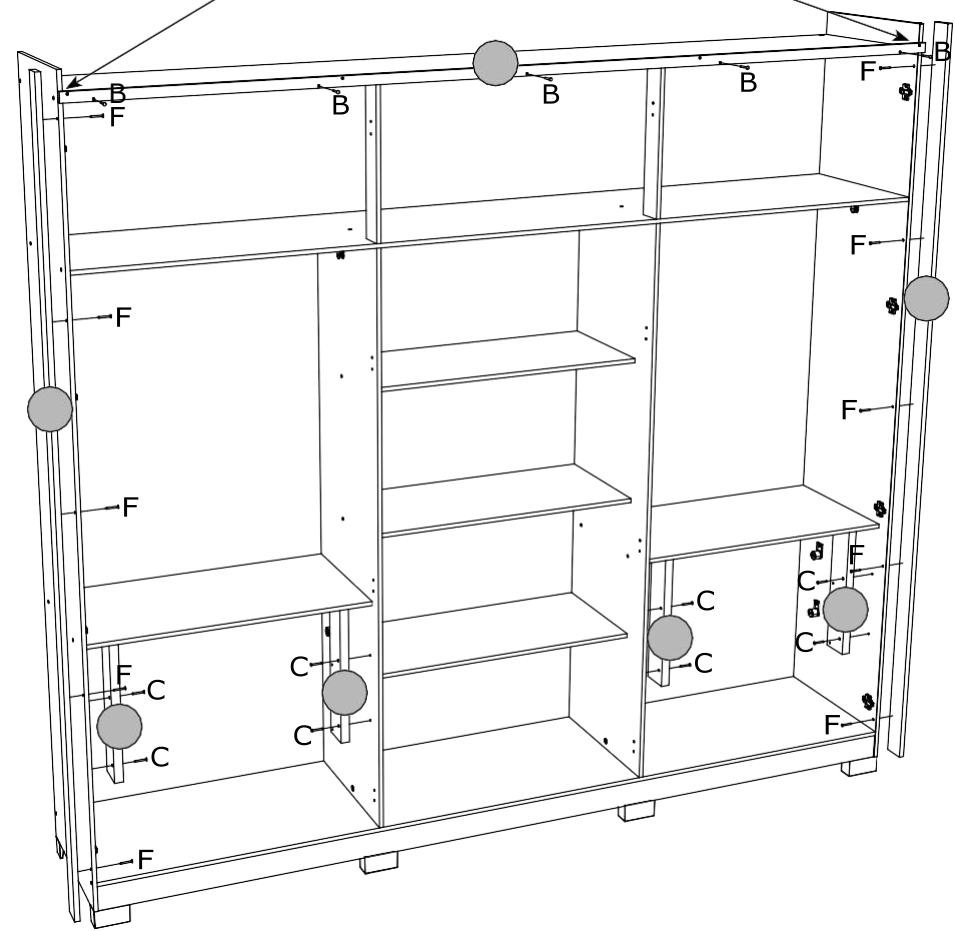
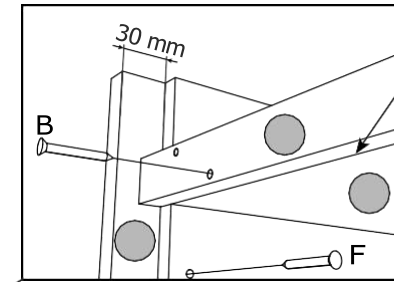
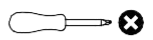



PASSO 7

ITM/D325-

PEÇAS REQUERIDAS

10	CHÃO DO MALEIRO	x1
11	RIPA DO MALEIRO	x2
12	LATERAL DIREITA	x1
13=7	TAMPO DAS GAVETAS	x1
14	TAMPO SUPERIOR	x1

ACESSÓRIOS REQUERIDOS

A		06
B		14

FERRAMENTAS NECESSARIAS

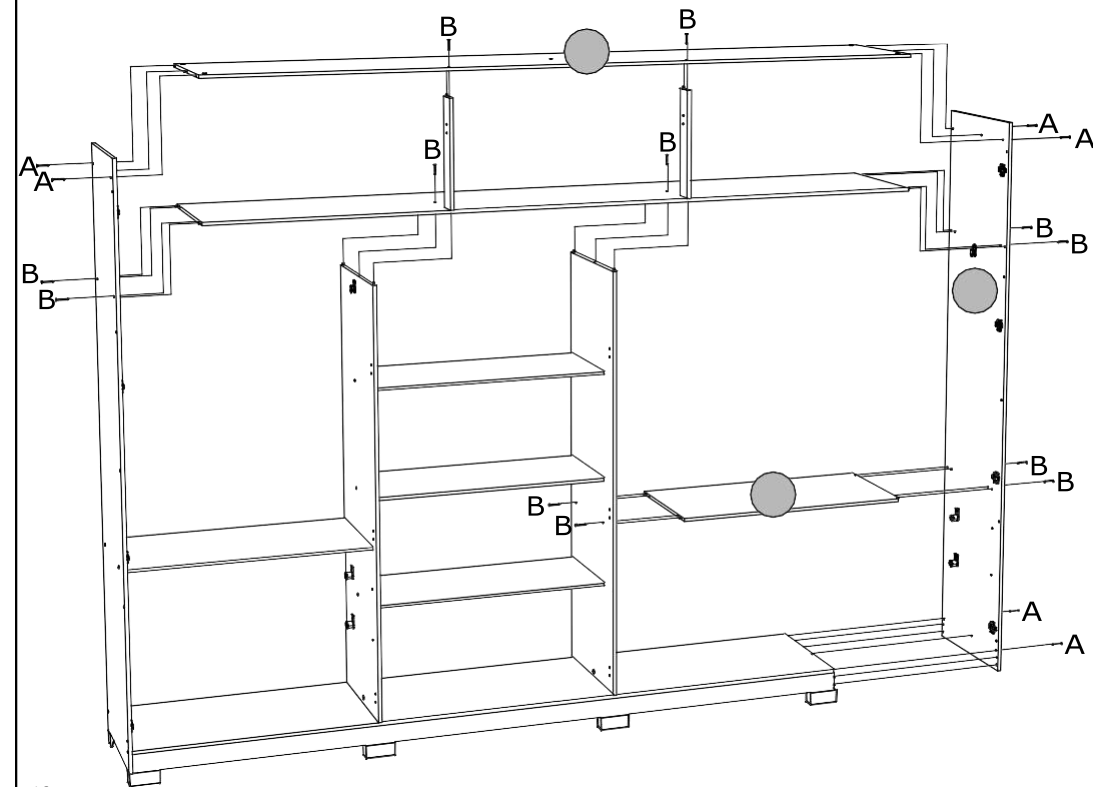
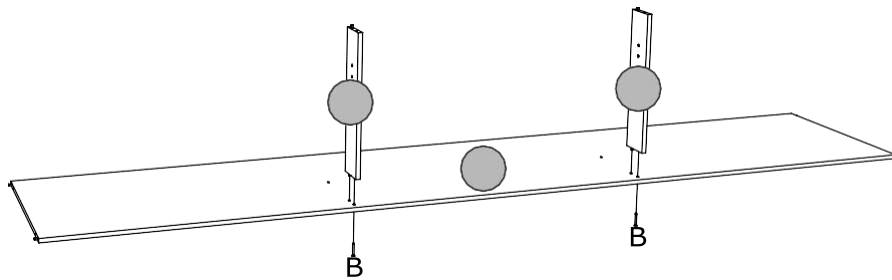
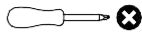

PASSO 4

ITM/D325-

PEÇAS REQUERIDAS

1	RODAPÉ FRONTAL	x1
2	TRAVESSA DO RODAPÉ	x2
3	RODAPÉ TRASEIRO	x1

ACESSÓRIOS REQUERIDOS

1		04
---	---	----

FERRAMENTAS NECESSARIAS

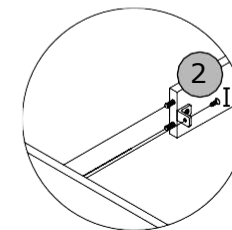
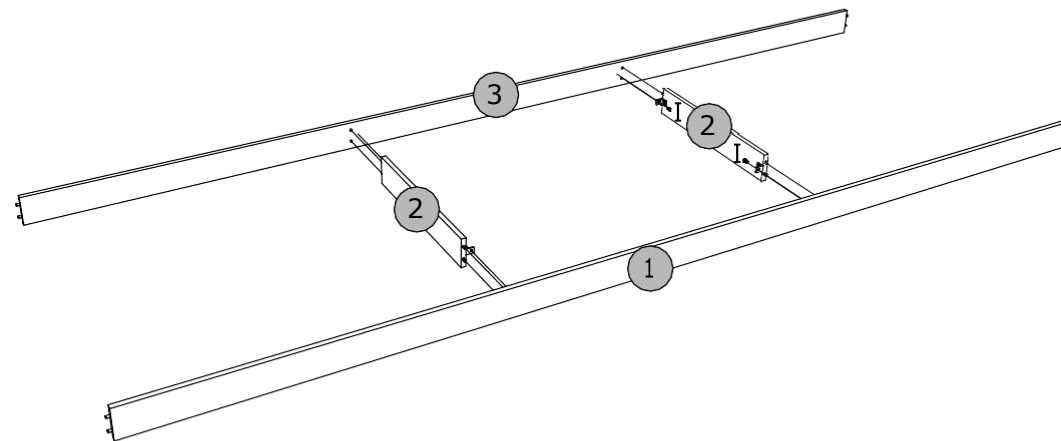
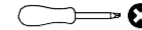

PASSO 5







ITM/D325-

PEÇAS REQUERIDAS

ACESSÓRIOS REQUERIDOS

FERRAMENTAS NECESSÁRIAS

4	BASE	x1
5	LATERAL ESQUERDA	x1
6	DIVISÃO ESQUERDA	x1
7	TAMPO DAS GAVETAS	x1

A		02
B		04
I		36
L		01
S		06
Y		08

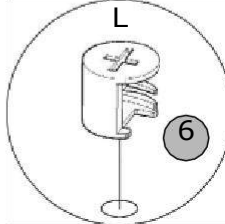
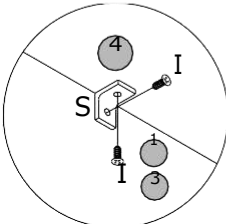
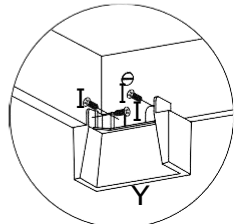
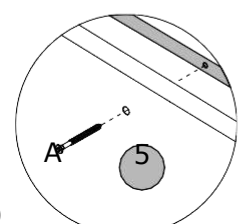
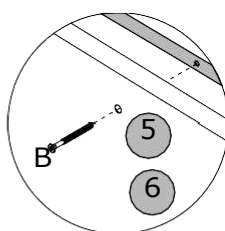
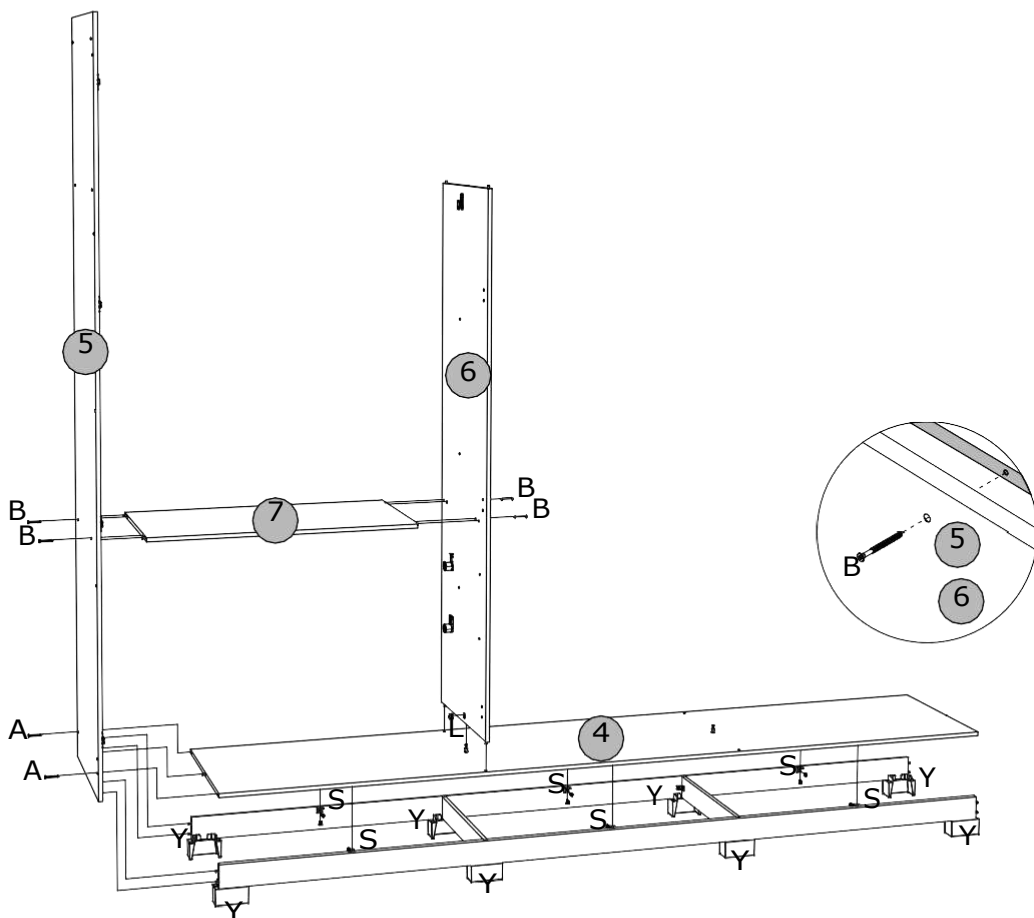
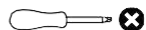

PASSO 6



ITM/D325-

PEÇAS REQUERIDAS

ACESSÓRIOS REQUERIDOS

FERRAMENTAS NECESSÁRIAS

8	DIVISÃO DIREITA	x1
9	PRATELEIRA	x3

B		06
L		01

