

O W N E R ' S M A N U A L

270

*Sundancer<sup>®</sup>*  
*Amberjack*  
*Hard Top*  
*Sport Fisherman*

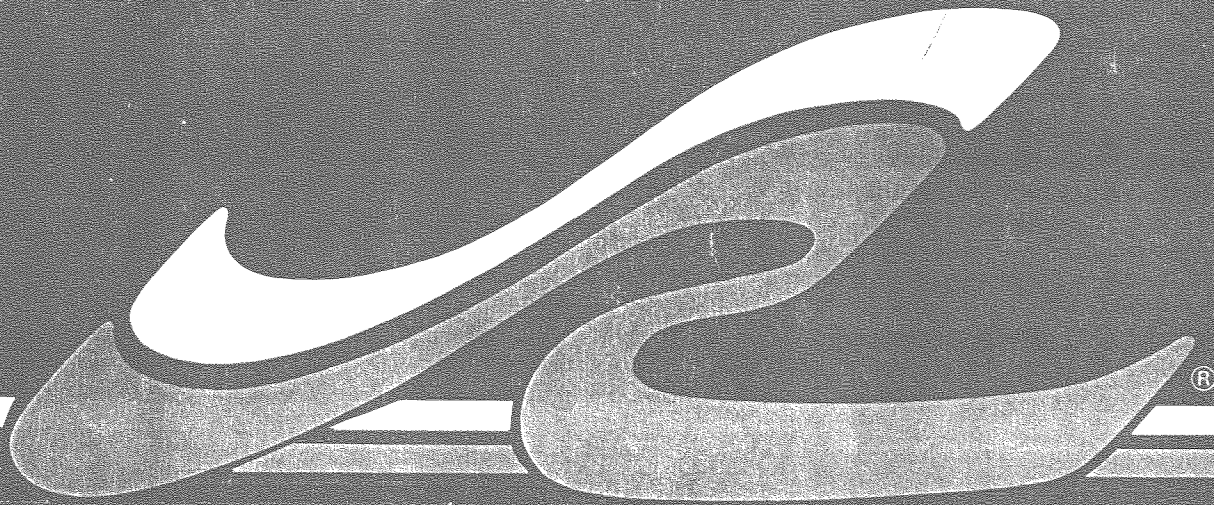

*Sea Ray*

# Welcome

As the new owner of America's most prestigious sport cruiser, we at Sea Ray Boats, Inc. would like to welcome you into our world-wide and ever-expanding fraternity of boating enthusiasts.

A nautical adventure is about to unfurl, bringing you excitement with each cruise and convenience from the beginning of every voyage until the moment you arrive safely at home port.

SEA RAY®'s commitment - Excellence by Design - has enabled us to create a superior craft providing you with comfort, performance, safety and dependability. All of our boats comply with the safety standards set by the United States Coast Guard and are designed, engineered and manufactured in accordance with applicable recommendations and guidelines of the National Marine Manufacturers Association (NMMA) and the American Boat and Yacht Council (ABYC).

This Owner's Manual - to be kept onboard your SEA RAY - introduces you to all the features which make

our boats so incomparable. For years of trouble-free boating, take the time **now** to carefully review the information in the Owner's Packet and this manual and **really** get to know your boat!

Because our Product Development and Engineering division is continually upgrading our products, some of the descriptions contained in this manual may differ somewhat from the actual equipment on your boat. If this occurs, please disregard those sections and refer directly to the updated information contained in the accompanying Owner's Packet.

Because your purchase represents a substantial investment, we know you will want to take the necessary measures to protect its value. We suggest you plan a program for proper operation, routine periodic maintenance and attention to safety inspections. If you have questions which are not fully covered by this manual or the manufacturer's instructions, please consult your authorized dealer for assistance.

Thank you for selecting a SEA RAY!

## Bon Voyage



# Table of Contents

---

## Section 1

### GENERAL INFORMATION

Warranty .....	1
For Your Information .....	1
Dealer's Responsibilities .....	1
Consumer Responsibilities .....	2
Safety .....	2
Grounding and Towing .....	3
Government Regulations .....	3

## Section 2

### INTRODUCTION TO YOUR BOAT

Bilge .....	8
Engines .....	10
Fuel Systems .....	11
Underwater Gear .....	13
Instruments and Controls .....	15
Fueling and Starting Procedures .....	20
Water Systems .....	21
Head Systems .....	23

## Section 3

### ELECTRICAL SYSTEMS

DC Systems .....	27
AC Systems .....	30
Generators .....	32
Electrolysis .....	33

## Section 4

### ACCESSORIES

Air Conditioner .....	35
Canvas .....	35
Central Vacuum System .....	37
Halon System .....	37
Horns .....	37
Power Ventilation System .....	37
Refrigerator/Freezer .....	37
Searchlight .....	38
Stereo .....	38
Stoves .....	38
Windlasses .....	38

## Section 5

STORAGE & SLEEPING ACCOMMODATIONS .....	41
---	----

**Section 6**

**STORAGE AND LAUNCHING PROCEDURES**

Laying-Up Instructions ..... 43  
Fitting Out After Storage ..... 45

**Section 7**

**CARE AND REFINISHING ..... 47**

**Section 8**

**SERVICE INFORMATION ..... 49**



(Information in this publication is based upon the latest product specifications available at printing. Sea Ray Boats, Inc. reserves the right to make changes at any time, without notice, in the colors, equipment, specifications, materials and prices of all models, or to discontinue models. Should changes in production models be made, SEA RAY® is not obligated to make similar changes or modifications to models sold prior to the date of such changes.)

# Section 1

## GENERAL INFORMATION

### Warranty

For a period of one year from the date of delivery to the original retail purchaser, Sea Ray Boats, Inc. warrants each SEA RAY® boat operated under normal, non-commercial use to be free from defects caused by faulty workmanship or materials.

During this period, warranty repairs will be made without charge by the selling SEA RAY dealer at the dealer's store or service center or, at SEA RAY's option, at one of SEA RAY's manufacturing plants. Transportation costs to and from the selling SEA RAY dealer's service center or to the SEA RAY plant are the responsibility of the purchaser. All warranty repairs must be approved by an authorized SEA RAY representative.

Engines, outdrives, controls, batteries and other equipment or accessories carrying their own individual warranties provided by their respective manufacturers are not covered by the provisions of this warranty.

This warranty does not cover boats owned by other than the original retail purchaser; windshield breakage; gelcoat crazing, fading or blistering; upholstery damage, scratches or tears; leakage around windshields, hatches and canvas; boats used for commercial or racing purposes; or boats or parts which have been altered or subjected to misuse or negligence.

The obligation of Sea Ray Boats, Inc. under this warranty shall be limited to the repair or replacement of any part which is judged defective by Sea Ray Boats, Inc. Sea Ray Boats, Inc. will not be liable for haul out, launch, towing or storage charges, inconvenience or loss of time or income, or any other special or consequential damages of any kind or nature. Implied warranties, if any, shall be limited to the duration of this written limited warranty.

Some states do not allow the exclusion or limitation of incidental or consequential damages or limitations on how long an implied warranty lasts, so the limitations and exclusions stated in this paragraph may not apply to you. This warranty gives you specific legal rights, and you may also have other rights that may vary from state to state.

### For Your Information

#### OWNER'S PACKET

Throughout this manual we will be referring to your Owner's Packet. This accordion-type file with alphabetical pockets contains the Sea Ray Owner's Manual, a plastic navigation chart and instructions on the warranties, use, adjustment and maintenance of installed equipment and accessories. It also contains the Engine Operator's Manual which covers the warranty, service, specification of oils and grease, proper gauge readings, 20-hour check and other precautions concerning your engines. Use your Owner's Packet to retain instructions and data on additional equipment or accessories installed after delivery.

#### PARTS AND EQUIPMENT

The personal equipment and supplies accumulated on a boat can amount to a great deal more weight than the owner realizes — with a possible loss of speed. Such weight should be kept to a reasonable minimum. When accessories or extra items are added, consider their weight and select their location to maintain the desired trim of the boat, fore, aft and athwartship. A drop in RPMs will be noted as weight is added and it may be advisable to change propeller size to compensate. Consult your SEA RAY dealer when considering the addition of a major weight.

Replacement parts or additional equipment may be purchased through your SEA RAY dealer.

#### Dealer's Responsibilities

Although your boat has undergone a series of rigid inspections throughout the manufacturing process, the final factory check is not the last one before you take delivery. Your dealer has been trained to perform additional pre-delivery checks and to service your SEA RAY in preparation for delivery.

**Dealer responsibilities include providing:**

- An adequate orientation in the general operation of your SEA RAY® boat.
- An "In Service Form" to be completed and signed by both the dealer and the consumer.
- An explanation of safety considerations regarding the use of containment systems and components.
- A complete Owner's Packet containing literature and information regarding your SEA RAY boat and its separately warranted products, warranty and registration cards, and operation, installation and maintenance instructions.
- A review of all warranties, pointing out the importance of mailing warranty cards and registrations to various manufacturers within the required time limits, and assistance in accomplishing same.
- Instructions on obtaining local and out-of-area service during and out of warranty periods.

---

## Consumer Responsibilities

*It is the owner's responsibility to:*

- Read and understand the limited warranty.
- Read all literature and instructions and use all equipment in accordance therewith.
- Examine the boat and assure all systems are working properly at the time of accepting delivery.
- Provide proper maintenance and periodic servicing of the boat in accordance with the Service Guide and Owner's Manual.
- Return the boat after 20 hours of operation to the selling dealer for its 20-hour inspection.

When contacting your dealer regarding warranty or service, please have all pertinent information such as serial numbers, model numbers, etc. on hand.

Sea Ray Boats, Inc. has a permanent record of your boat, which is retained under its "Hull Identification Number." Data is kept regarding equipment and accessories, as well as dealer/shipping information.

The "Hull Identification Number," located on the starboard side of the transom below the gunwale, is the most important identifying factor and must be included in all correspondence and orders. Failure to include it only creates delays. Also of vital importance are the engine serial numbers and part numbers when writing about or ordering parts for your engines.

---

## Safety

Your safety, as well as the safety of your passengers and craft, are your responsibility. Familiarize yourself with the following safety precautions before using your boat.

### DANGER

In all gasoline powered boats, engine and generator exhaust systems produce colorless and odorless carbon monoxide gas ("CO"). Direct prolonged exposure can result in CO poisoning which may be harmful or fatal. To prevent excess exposure and reduce the possibility of accumulation of CO in the cabin and cockpit of the boat, the operator should insure adequate ventilation in each the cabin and cockpit areas, through utilization of cabin hatches, cabin doors, cabin windows, cockpit windshield windows and side windshield vents to increase air movement through the cabin and cockpit areas. The following conditions tend to increase the accumulation of CO in and about the boat and require the operator's particular attention:

- (1) Operation at slow speeds or dead in the water.
- (2) Operation with a high bow angle attitude.
- (3) The utilization of canvas top, side curtains & back curtains.
- (4) Contributing climatic conditions, such as a head wind.
- (5) Operations of engines and/or generator in confined spaces or at dockside.
- (6) Any blockage of hull exhaust outlets.

Indications of excessive exposure to CO concentrations may include nausea, dizziness and drowsiness.

### EXAMPLES OF HOW HIGH LEVELS OF CARBON MONOXIDE MAY ACCUMULATE

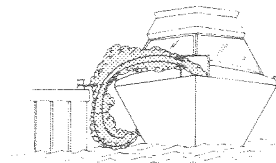

**WARNING:** ANY BLOCKAGE OF HULL EXHAUST OUTLETS BY A SEAWALL BULKHEAD OR ANY OTHER OBSTRUCTION, CAN CAUSE EXCESSIVE ACCUMULATION OF CARBON MONOXIDE IN THE BOAT'S INTERIOR.

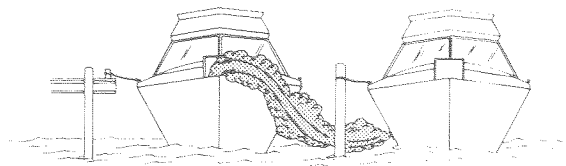

**WARNING:** WHEN YOU ARE TIED TO A DOCK AND/OR IMMEDIATELY ALONGSIDE OF OTHER VESSELS, PAY PARTICULAR ATTENTION TO THE GENERATOR EXHAUST EMISSIONS FROM THE NEARBY VESSELS.

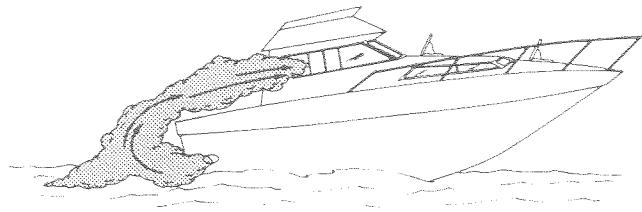

**WARNING:** WHEN OPERATING BOAT WITH HIGH BOW ANGLE PAY PARTICULAR ATTENTION TO THE ENGINE EXHAUST EMISSIONS AS TO INSURE THAT EMISSIONS DO NOT ACCUMULATE IN BOAT INTERIOR.

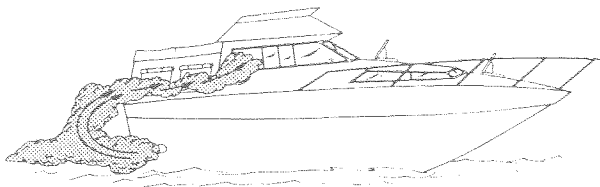

**WARNING:** WHEN OPERATING BOAT WITH CANVAS TOPS, SIDE CURTAINS, AND/OR BACK CURTAINS IN PLACE, PAY PARTICULAR ATTENTION TO THE ENGINE EXHAUST TO INSURE THAT EMISSIONS DO NOT ACCUMULATE IN BOAT INTERIOR AND PROPER VENTILATION IS ADDED.

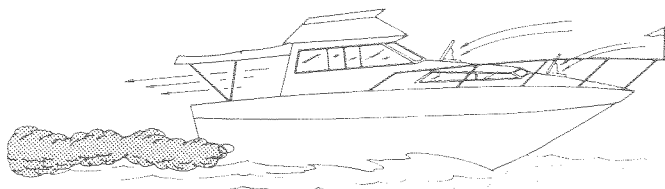

**CORRECT VENTILATION.**

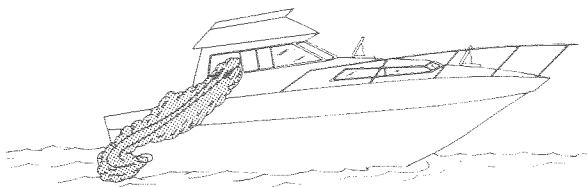

**WARNING:** WHEN OPERATING BOAT AND/OR GENERATOR WITH BOAT AT SLOW SPEED OR DEAD IN THE WATER PAY PARTICULAR ATTENTION TO THE ENGINE EXHAUST EMISSIONS AS TO INSURE THAT EMISSIONS DO NOT ACCUMULATE IN BOAT INTERIOR DUE TO WIND CONDITIONS.

- Keep your boat and equipment in top condition by frequently inspecting the hull, engines and all gear.
- Use maximum caution when taking on fuel. Know your fuel tank capacity and fuel consumption at various RPMs.
- Be certain there is enough fuel aboard for your anticipated cruising needs and an adequate reserve if you must change your plans for weather or other reasons.
- Make sure that regulation lifesaving and fire fighting equipment is on board and in proper working condition. They should be conspicuous, easily accessible, and your passengers should be instructed in their use.
- Watch the weather. Check local weather reports before departure. Be especially on the lookout for strong winds and electrical storms.
- Always have up-to-date charts of your area on board.
- File a float plan.
- Instruct at least one of your passengers in the basic fundamentals of handling your boat in the event you are unable to do so.
- Do not overload or improperly load your boat.
- Do not permit passengers to ride on parts of your boat not designed for such use.
- **Do not use the swim platform or boarding ladder while the engines are running.**
- **CAUTION: Running boat with cabin door open (and windows in aft berth on SDA) could induce exhaust fumes into the cabin.**
- Know and obey the Rules of the Road and always maintain complete control of your boat.

- Always operate with care, courtesy and common sense.

## Grounding And Towing

If you unfortunately find yourself aground and unable to pull off with your own power, or in need of a tow, or if you wish to help another craft from either predicament, remember that there is no way of knowing the amount of pull or strain which will be required. The stress may easily exceed the strength of the cleats and their fastenings. Cleats are designed and located for mooring use **only**.

**WARNING: DO NOT USE DECK HARDWARE FOR GROUNDING AND TOWING!**

The boat structure itself can be damaged by an excessive pulling strain. It is much safer, in these cases, to form a bridle by passing a line completely around the hull. Do this for both the pulling boat and the one being aided.

Some synthetic fiber rope should not be used for pulling or towing (except a light dinghy). The characteristic ability of some types of rope to stretch, which makes it desirable for anchor and dock lines, renders it extremely dangerous if the line breaks or if the fitting to which it is attached breaks loose while under stress. The preferred line for towing is double-braided nylon. It has sufficient elasticity to cushion shock loads, but not so much as to create a snap-back hazard. Any type of line breaking under stress is dangerous and over-stressing should be avoided. **ALWAYS STAND CLEAR OF ANY TAUT LINES.**

## Government Regulations

The Coast Guard is an ever-present help to the boating public. Its boating regulations prescribe minimum standards of safety, and you must equip your boat to comply with these regulations. The following is a list of the safety equipment required for a boat 26 feet to less than 40 feet. These requirements may vary from state to state. Consult your SEA RAY® Dealer for variations to these requirements in your area.

- At least three B-I type hand-held fire extinguishers.
- At least one Coast Guard approved (Type 1, 2, or 3) personal flotation device (life jacket) for each person aboard. (If over 20 miles offshore, they must be Type 1.)

- At least one Type 4 device designed to be grasped instead of worn (ring buoy or buoyant cushion).
- At least three approved hand-held red pyrotechnic distress signals; three approved aerial red pyrotechnic distress signals for night use; and three approved international orange smoke signals for daytime use.
- All pyrotechnic devices must be stowed in waterproof, non-glass containers.
- One power-operated whistle or horn, audible for at least half a mile.

It is recommended that you also carry an anchor, anchor line, tie-up lines, fenders, first aid kit, waterproof flashlight, spare fuses, electrical tape and tools to make minor repairs.

## DISCHARGE OF OIL

The Federal Water Pollution Control Act prohibits the discharge of oil or oily waste into or upon the navigable waters and contiguous zones of the United States, if such discharge causes a film or sheen upon, or discoloration of, the surface of the water, or causes a sludge or emulsion beneath the surface of the water. Violators are subject to a penalty of \$5,000.

## RULES OF THE ROAD

Your boat is subject to Coast Guard-enforced marine traffic laws known as "Rules of the Road." There are two sets of rules — the United States Inland Navigational Rules and the International Rules. The United States Inland Rules are applicable to all vessels inside the demarcation lines separating inland and international waters. The "Rules of the Road" can be obtained from your local Coast Guard unit or from the United States Coast Guard Headquarters (1300 E. Street NW, Washington, D.C. 20226) in the publication "*Navigational Rules, International-Inland.*"

"*Aids to Navigation*" (Coast Guard pamphlet no. 123) explains the significance of various lights and buoys. This and other pamphlets, including the "*Boating Safety Training Manual*," and "*Federal Requirements For Recreational Boats*" are also available from the United States Coast Guard Headquarters.

Because of proposed alterations in buoys and markers, we advise you to periodically contact



the Coast Guard to stay apprised of impending changes.

If you have ship-to-shore radio telephone aboard, heed storm warnings and answer any

distress calls. The spoken word "MAYDAY" is the international signal of distress. NEVER use this word unless there is danger close at hand — an emergency — and you are in need of immediate assistance.

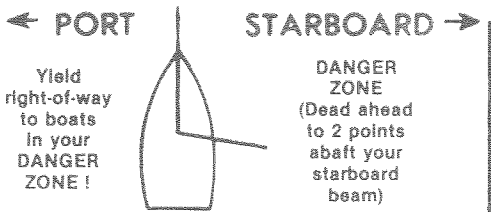

**REMEMBER THESE RULES**

- 1. OVERTAKING - PASSING:** Boat being passed has the right-of-way. **KEEP CLEAR.**
- 2. MEETING HEAD ON:** Keep to the right.
- 3. CROSSING:** Boat on right has the right-of-way. Slow down and permit him to pass.

**WHISTLE SIGNALS**

- ONE LONG BLAST:** Warning signal (Coming out of slip)
- ONE SHORT BLAST:** Pass on my port side
- TWO SHORT BLASTS:** Pass on my starboard
- THREE SHORT BLASTS:** Engines in reverse
- FOUR OR MORE BLASTS:** Danger signal

**STORM WARNINGS**

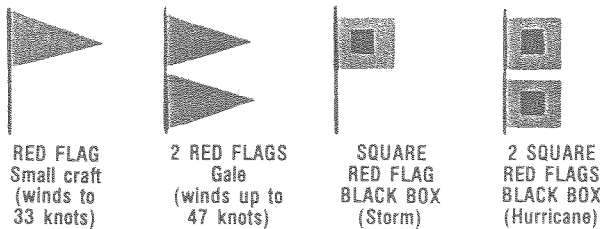

**BRIDGE SIGNALS**

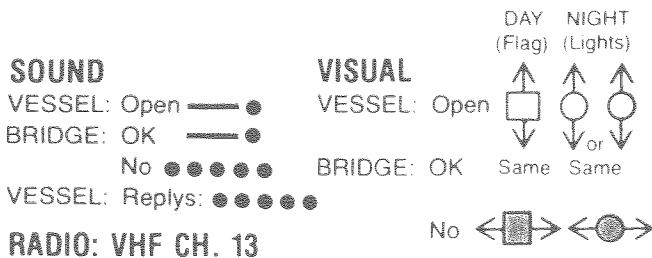

**LATERAL AIDS AS SEEN ENTERING FROM SEAWARD**

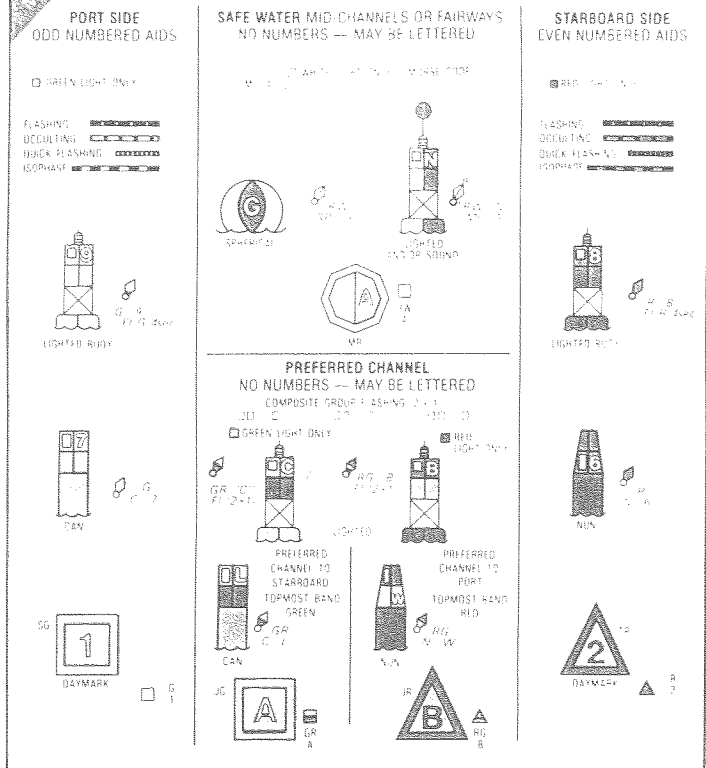

**REMEMBER: RED RIGHT RETURNING**

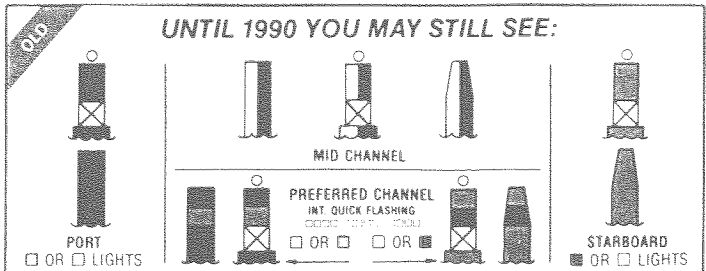

# Section 2

## INTRODUCTION TO YOUR BOAT

### Specification Sheet

#### 270 SUNDANCER®

Length:	27'7" (8.4 m)
Beam:	120" (3.05 m)
Dry Weight:	6700 lbs. (3039 kg)
Dead Rise:	22°
Draft (Stern Drive Up):	15" (38.10 cm)
Draft (Stern Drive Down):	32" (81.28 cm)
Water Capacity:	28 gal. (105.9 litres)
Fuel Capacity:	124 gal. (469.3 litres)
Usable Fuel*:	102 gal. (368.1 litres)

#### HEIGHT DIMENSIONS

Waterline to top of Windshield:	6'7" (2.01 m)
Waterline to Mast Light on Arch:	9'4" (2.84 m)
Keel to top of Windshield	8'4" (2.54 m)
Keel to top of mast light on arch:	10'9" (3.28 m)

#### 270 AMBERJACK

Length:	27'7" (8.4 m)
Beam:	120" (3.05 m)
Dry Weight:	6570 lbs. (2980 kg)
Dead Rise:	22°
Draft (Stern Drive Up):	15" (38.10 cm)
Draft (Stern Drive Down):	32" (81.28 cm)
Water Capacity:	28 gal. (105.9 litres)
Fuel Capacity:	200 gal. (757.0 litres)
Usable Fuel*:	170 gal. (643.4 litres)

#### HEIGHT DEMENSIONS

Waterline to top of Windshield	6'3" (1.91 m)
Keel to top of Windshield	8'3" (2.52 m)

#### 270 HARDTOP

Length:	27'7" (8.4 m)
Beam:	120" (3.05 m)
Dry Weight:	6800 lbs. (3084 kg)
Dead Rise:	22°
Draft (Stern Drive Up):	16" (40.64 cm)
Draft (Stern Drive Down):	33" (83.82 cm)
Water Capacity:	28 gal. (105.9 litres)
Fuel Capacity:	200 gal. (757.0 litres)
Usable Fuel*:	170 gal. (643.3 litres)

#### HEIGHT DIMENSIONS

Waterline to top of Windshield:	6'9" (2.06 m)
Keel to top of Windshield:	8'9" (2.67 m)

#### 270 SPORTFISH

Length:	27'7" (8.4 m)
Beam:	120" (3.05 m)
Dry Weight:	6950 lbs. (3153 kg)
Dead Rise:	22°
Draft (Stern Drive Up):	16" (40.64 cm)
Draft (Stern Drive Down):	33" (83.82 cm)
Water Capacity:	28 gal. (105.9 litres)
Fuel Capacity:	200 gal. (757.0 litres)
Usable Fuel*:	170 gal. (643.3 litres)

#### HEIGHT DIMENSIONS

Waterline to Bridge Rail:	9'9" (2.97 m)
Keel to Bridge Rail:	11'9" (3.58 m)

\* Allow 15% reserve in rough seas.

### 270 SportFish & Hardtop Bilge Layout

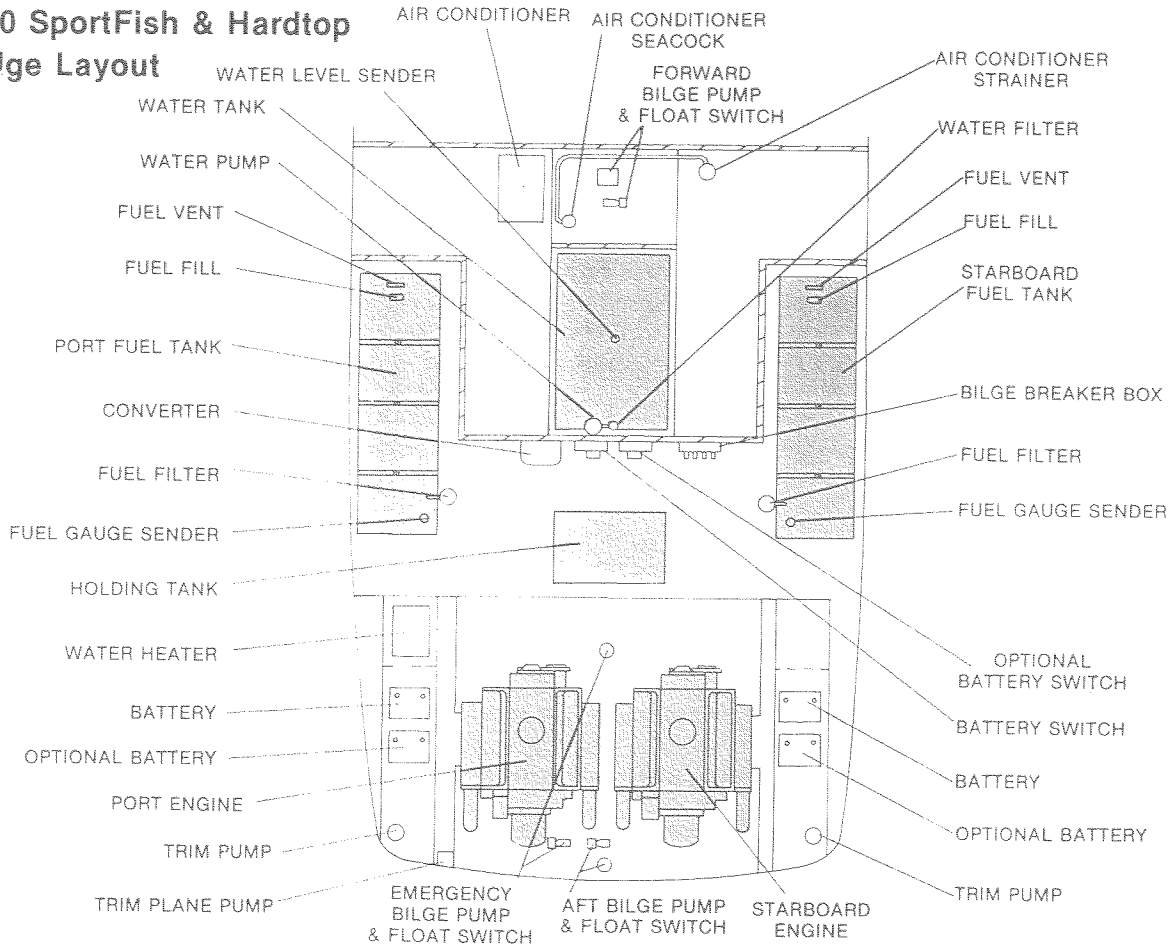

### 270 Amberjack Bilge Layout

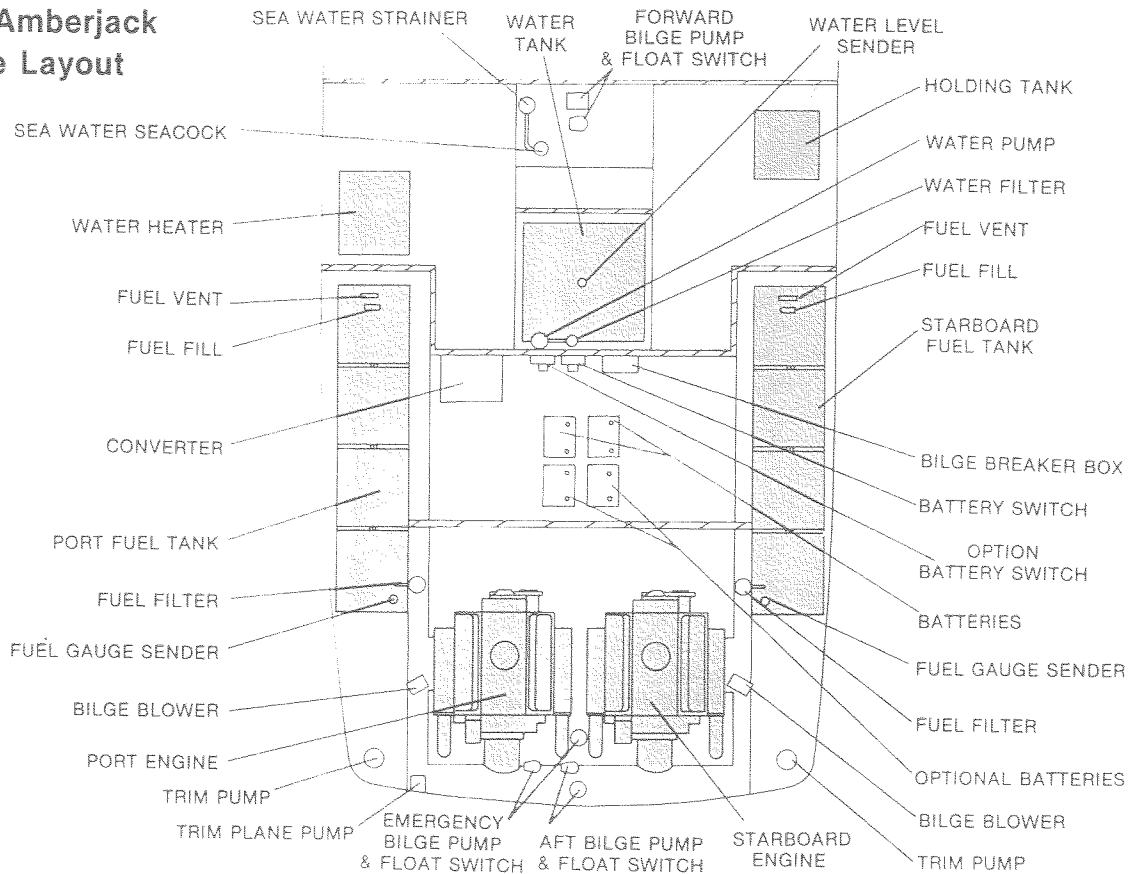

## 270 Sundancer®

### Bilge Layout

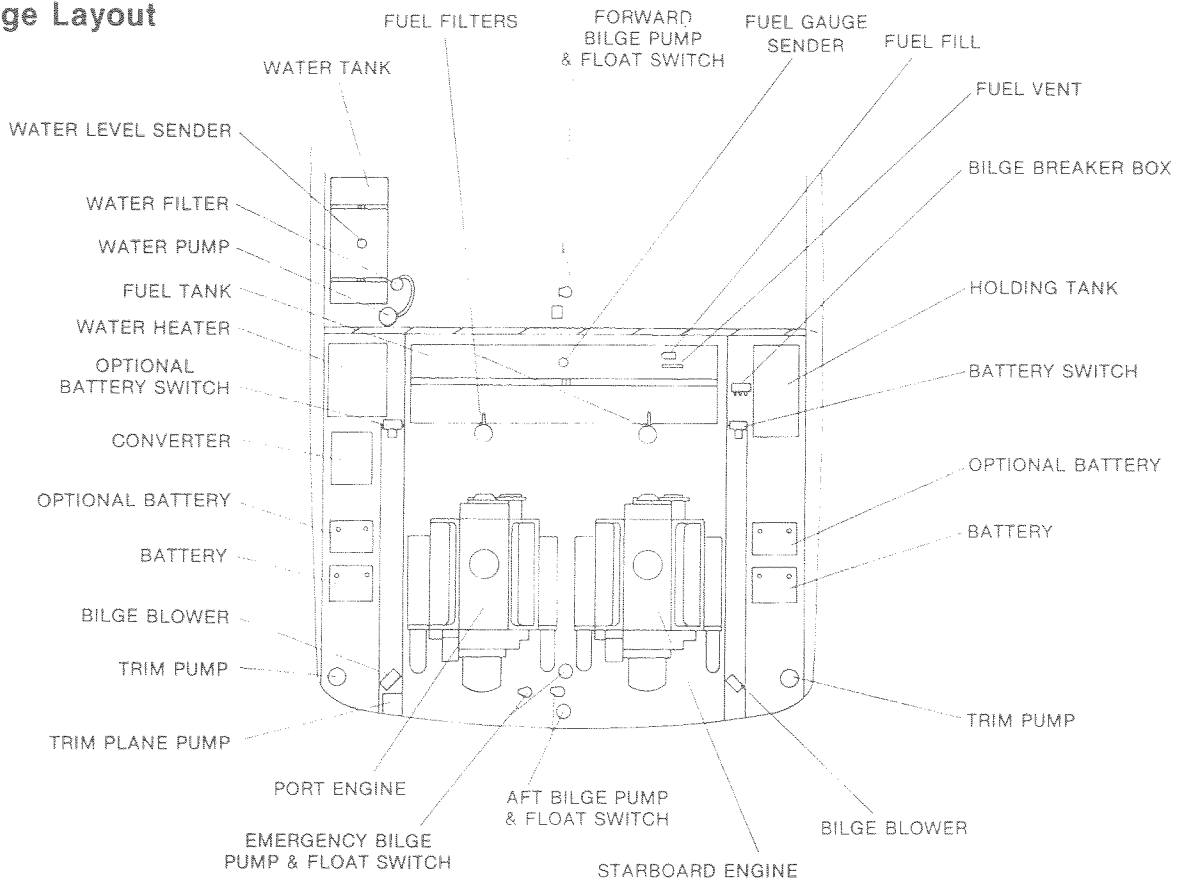

## Bilge

### BILGE PUMPS

Your SEA RAY® has two bilge pumps with float switches wired to the batteries through a 10 amp circuit breaker on the bilge breaker box.

The aft pump is equipped with a switch on the dash with a "manual" and "auto" mode. The second pump is wired to the high water bilge alarm located under the helm.

When the switch is in the "manual" position, the pump will run continuously. When in the "auto" position, the pump is activated when there is enough water in the bilge to raise the float switch to its highest position; and deactivated when the water level recedes. The pumps should be left in the "auto" mode unless the bilge is being pumped out for servicing.

Because of the weight of water, 8.3 pounds per gallon, it is important to keep the bilge as free from water as possible.

Frequently inspect the area under the float

switches to assure they are free from debris and gummy bilge oil. To clean, soak in heavy duty bilge cleaner for 10 minutes, agitating several times. Check for unrestricted operation of the float. Repeat the cleaning procedure if necessary.

Inspect the bilge pump intakes and keep them free of dirt or material which may impede the flow of water through the pump. To clean the pump strainer, depress the lock tabs on both sides of the pump and lift the pump cover.

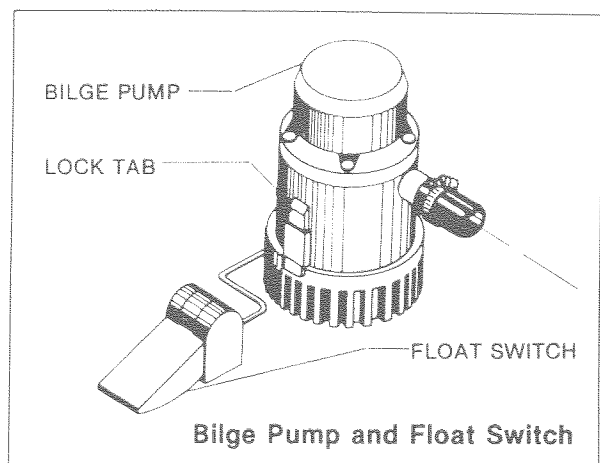

**Bilge Pump and Float Switch**

## BLOWERS

Your SEA RAY® is equipped with two in-line bilge blowers to provide bilge ventilation. The blowers are wired through a circuit breaker panel with a double switch on the dash panel. Run the blowers for four minutes before starting the engines, when operating below cruising speed, and when the generator is running.

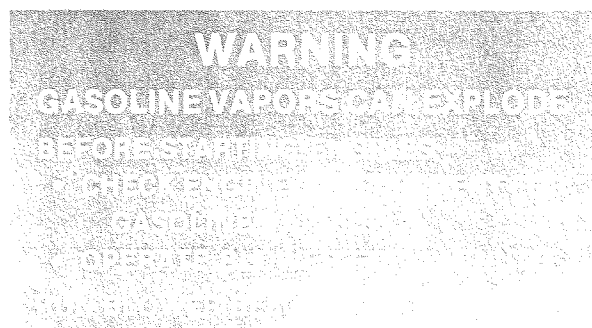

**Maintenance:** The bilge blowers should be checked periodically to insure that the hoses are securely fastened to the blowers. Check for corrosion of wires and make sure 12-volt wires are secured in place.

**Trouble Shooting:** If your bilge blower fails to operate:

- (1) Check the breaker at the helm switch panel.
- (2) Check to see if the blower hose is fastened to the blowers.

## Engines

The engines are the heart of your SEA RAY boat. Proper attention to and maintenance of your engines will assure you of many hours of pleasurable, safe boating and will prevent unnecessary engine problems. A general maintenance program consists of proper lubrication, cleaning of fuel filters, fuel lines and air filters. When washing down, or at any other time, take care that water does not enter the carburetor (on gasoline engines), or the air inlet (on diesel engines). Water entering the carburetor or air inlet when the engine is not operating may go directly into the cylinders, resulting in rust and possibly bent rods. Follow the recommended maintenance schedule in your Engine Operator's Manual.

## ALARM SYSTEMS

Your engines are equipped with two alarm switches — water temperature and oil pressure connected to an alarm buzzer located behind the dash. The warning buzzer will sound if the cooling system water temperature rises too

high or the engine oil pressure gets too low. Refer to the Engine Operator's Manual for proper gauge readings or aid in finding and correcting the problem.

**CAUTION:** If the engine stalls during docking or slow maneuvering, the buzzer will sound until the engine is restarted. The buzzer will also sound while the engines are cranking and will continue until they start. **IF THE ALARM SOUNDS WHILE THE ENGINES ARE OPERATING, QUICKLY CHECK AND NOTE THE OIL PRESSURE AND WATER TEMPERATURE GAUGES. TURN ENGINE OFF IMMEDIATELY.** Check for leaks and see if the cooling water pick-up is blocked or clogged. If necessary, clear the water pick-up of any foreign matter. **DO NOT RESTART THE ENGINE UNTIL CAUSE FOR ALARM SOUNDING HAS BEEN FOUND AND CORRECTED.**

## ENGINE REMOVAL

Should the removal of an engine become necessary, see your SEA RAY® dealer. The following is only a generalized procedure to follow.

Remove drive unit. Shut off the fuel lines. Remove all electrical wires and fuel lines from the engine. Detach both throttle and shift cables. **Do not bend or twist the cables, as damage may result.**

Remove rear engine mount bolts. Loosen the mounting bolts for the engine and lift the engine out. Remove water intake hose.

To reinstall, reverse the above procedure. Check the water hose and wiring connections. Also check for fuel leaks.

## VIBRATION AND CAUSES

Some vibration is to be expected in your boat because of the action of the engines and the propeller. But excessive vibration indicates conditions which must be promptly corrected to avoid damage. Following are some of the conditions which may cause vibrations:

**Foreign Object Interfering With Propeller Action:** Weeds, ropes, fishing lines or nets can become wrapped around the propeller and/or shaft, causing vibration and loss of speed. Always stop and then reverse the propeller after going through a weedy area to unwrap and clear away any weeds which may have accumulated. Although reversing will sometimes help to unwrap lines and nets, they are difficult to remove without hauling.

Always check for loose or trailing dock lines before getting underway. When towing a dinghy or surfboard, remember that a long line may easily become entangled with the propeller when backing down.

**Bent Prop:** A badly damaged or distorted prop or shaft is an obvious cause of vibration. Even when the propeller appears to be perfect, make sure it has not been pulled off-center by the prop key.

**Engine Part Hitting Boat Structure:** Engines are flexibly mounted to reduce transmission of vibration to the hull structure. If some part of the engine, such as the oil pan, reverse gear or reduction gear housing, contacts a stringer, brace or part of the hull, vibration will result.

## Fuel Systems

### FUEL TANKS

#### 270 AMBERJACK

#### HARDTOP & SPORTFISH

The two fuel tanks on board the AMBERJACK, HARDTOP and SPORTFISH have a 100-gallon capacity each and are accessible through the cockpit hatches. The fuel fills are located on the port and aft corners of the deck. Access to the fill and vent hoses is gained by removing the lower aft cockpit hatch.

#### 270 SUNDANCER®

The SUNDANCER fuel tank holds 124 gallons and is accessible through the cockpit hatch. The fuel fill is located on the starboard deck walkway. Access to the fill and vent hoses is gained by removing the secured center cockpit hatch.

The fuel pick-up on gasoline tanks has an anti-siphon device for safety in case of line failure. Boats with diesel engines have a manual shut-off valves on the fuel tanks.

Your SEA RAY® is equipped with a fuel tank vent which serves as a pressure/vacuum release and safety overflow. Periodically check the vent to assure that it is not clogged.

### FUEL SYSTEMS

Fuel lines, filters, and all fuel system components should be checked at the start of each season and periodically thereafter, particular-

ly after any work has been done aboard the boat which might have affected any part of the system. Be certain that all are in proper condition and the entire system is fuel tight.

**Standard Fuel System:** In the standard fuel system, the port engine draws fuel off the port tank and the the starboard engine draws off the starboard tank.

**Crossover Fuel System:** The crossover fuel system allows the generator and both engines to draw fuel from either tank. This allows switching to an alternate tank in case of fuel contamination or for even fuel weight distribution. The fuel valves are located midship on the forward bilge bulkhead. With diesel engines, the feed and return lines to the same tank must be open.

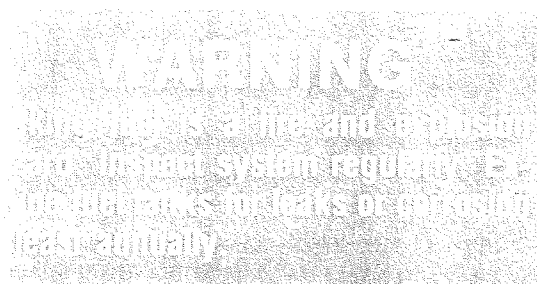

**CAUTION:** Never start an engine until you are certain that gasoline fumes are not present in the engine compartment or elsewhere in the boat.

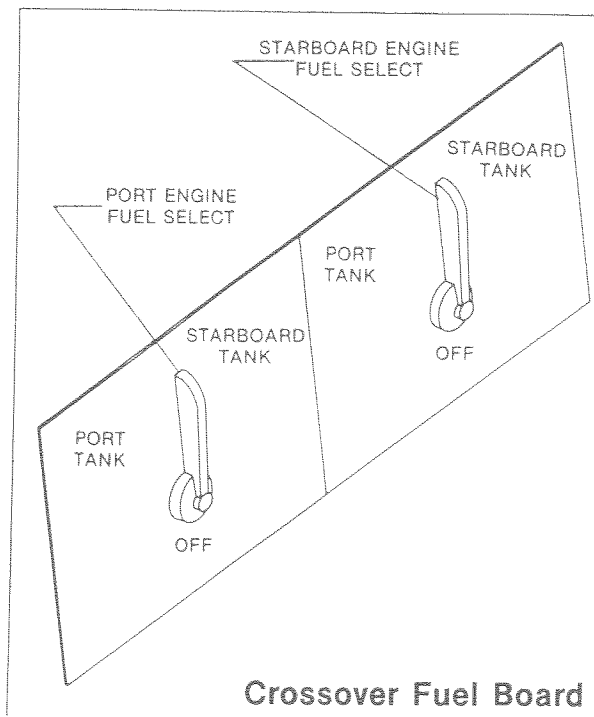

## FUEL RECOMMENDATIONS

### NOTICE

#### GASOLINE RECOMMENDATIONS

The use of any good grade regular leaded, premium, low-lead or lead-free automotive gasolines with a minimum posted octane rating of 86 are satisfactory for use in gasoline marine engines. Gasoline containing alcohol, either Methyl alcohol (Methanol) or Ethyl (Ethanol) may cause increased:

- (1) Corrosion of metal parts
- (2) Deterioration of rubber and plastic parts
- (3) Fuel permeation through flexible fuel lines
- (4) Wear and damage of internal engine parts
- (5) Starting and operating difficulties

AVOID USING FUELS WITH ALCOHOL ADDITIVES

SEA RAY® recommends the use of Shell Unleaded Gasoline for all gasoline engines used in SEA RAY boats.

Other gasolines acceptable for use are unleaded, alcohol free gasolines from Amoco Oil Co., Exxon, Marathon Petroleum Co., Mobile Oil Corp., Standard Oil and Texaco, Inc.

**Gasoline/Alcohol Mix:** Much of the gasoline sold today contains significant amounts of alcohol, although it is not sold as gasohol.

Some gasolines contain Ethanol (ETHYL ALCOHOL) which is made from grain. Other gasolines contain Methanol (METHYL ALCOHOL) which can be produced from natural gas, coal, trees, vegetation or even garbage. Methanol alcohol in gasoline can have a deteriorating effect on certain fuel system components. Floats (other than metal) can swell or shrink. Seals on accelerator pumps can swell and cause "bog" on acceleration. Fuel pump check valves can swell or diaphragm distort, causing a loss of fuel pump pressure. Fuel distribution lines can deteriorate and leak fuel into bilge. Methanol holds water in the fuel tank and causes the protective coating on the interior of the tank to corrode. All other rubber or Neoprene composition parts in the fuel system can be affected also.

Fuels containing alcohol have a tendency to absorb moisture slowly from the air. When the water content has built up to about 1%, the alcohol-water mixture settles at the bottom of the fuel tank and the engine will not run on it. Before the engine can be restarted, it will be necessary to remove the separated layer from the tank and flush out the fuel system with clean fuel. Another common occurrence is

permeation of alcohol (in vapor form) through fuel hose material into enclosed environments (engine compartments). It is important to check and ventilate the engine compartment for fuel-related fumes prior to starting engines.

Assume that your fuel is an alcohol-blended gasoline if not marked at the pump, and frequently inspect your fuel system components, particularly at the beginning of the season, replace any items that may have deteriorated and consult your dealer if you are uncertain about your fuel system's condition.

Storage of gasoline with a high content of alcohol in the fuel tanks for periods of more than a few days must be avoided in high humidity climates. Use gasoline containing the least amount of alcohol.

**Diesel Additives:** "Racor" diesel fuel additive should be added to the fuel tanks on a monthly basis and when winterizing to help keep injectors, pumps, fuel tanks and lines free of gum, sludge and wax and to help cold weather starts. **Use of any methanol, gasohol or alcohol based fuel additive will damage the fuel filter.** It is highly recommended that you keep the fuel tanks full to reduce condensation.

**NOTE: IN ROUGH SEAS, ALLOW APPROXIMATELY 15% RESERVE WHEN PLANNING FUEL CONSUMPTION.**

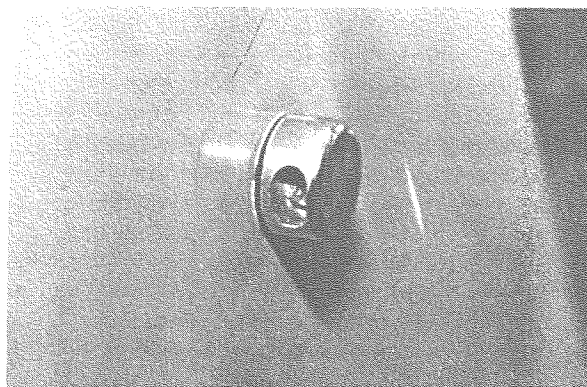

*Fuel Vent With Screen*

## COOLANT RECOMMENDATIONS

The standard mixture of water and coolant is a mixture of 30% antifreeze and 70% water, which protects to 0°F (-18°C). This will allow the coolant to expand properly and maintain normal operating engine temperature. In colder climates, the coolant level should be increased to 50/50, which protects to -34°F (-37°C), for proper coverage. **To find engine coolant capacity, refer to engine owner's manual in the owner's packet.**

# Underwater Gear

## PROPELLERS

Your SEA RAY® has been equipped with the propeller which our tests have shown to be the best suited for general use under normal conditions and load. In some situations you may wish to change propellers to give your boat slightly different performance characteristics. In general, changing to a *lower* pitched propeller will increase acceleration and load-pulling ability, but with a slight decrease in top speed. Conversely, moving to a higher pitch propeller will attain higher top speed with a light load, but will sacrifice acceleration and power. Your particular requirements should be discussed with your SEA RAY dealer. ***Under no circumstances use a propeller which allows the engine to operate at higher than recommended RPMs.***

**Basic Propeller Characteristics:** Propellers have two basic characteristics: diameter and pitch. Diameter is that distance measured across the propeller hub line from the outer edge of the 360° that is made by the propeller's blade during a single rotation. Pitch is the distance in inches that a propeller will travel if rotated one revolution with any slippage.

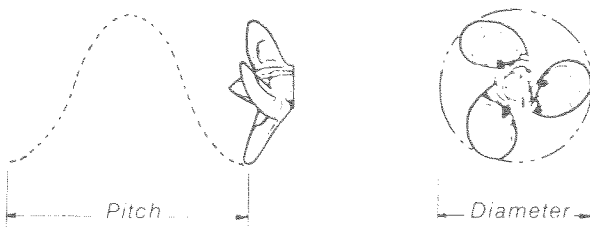

For example, a propeller with a 12-inch pitch, when rotated 360° would, theoretically, advance 12 inches through the water. Actually, no propeller applied to any boat is 100% efficient. No 12-inch pitch blade will, in a single rotation, advance a boat 12 inches. This variance is referred to as slippage.

**Ventilation, Its Causes and Corrections:** While often called "cavitation," ventilation is really a different effect. At times when a boat enters or leaves a sharp turn, the propeller seems to slip and lose thrust and the engine may overspeed. This problem is normally caused by air or aerated water entering the propeller. (A damaged propeller can also cause ventilation.) Ventilation can usually be corrected by one or more of the following:

- (1) Replace the damaged or incorrect propeller with the recommended one.
- (2) Set the outdrive at a lesser trim angle (trim the unit inward.)

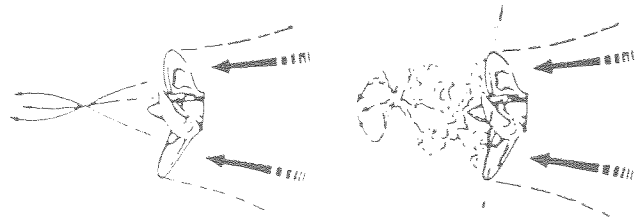

Optimum Performance

Ventilation

**Cavitation, Its Causes and Corrections:** Cavitation is a phenomenon that occurs in all propeller-driven craft under certain conditions.

The surface of propeller blades are not perfectly flat, and as water is drawn through the blades to be discharged aft into the propeller's slip stream, the water flowing over the curved surface of the blade encounters areas of greater and less pressure.

In those areas of reduced pressure air bubbles are formed. When they move out of the low pressure area these bubbles collapse. If they collapse while in contact with an object such as part of the propeller blade or the trim tab, the bubbles create such high localized forces that they erode the surface of the object. In the case of the propeller, such damage is sometimes called a "burn." It may be caused by an irregularity in the propeller's leading edge, and it should be corrected by reconditioning the prop or replacement.

Cavitation is a normal occurrence in modern sport boats, and prop inspection should be part of routine maintenance.

**Propeller Torque and Its Correction:** Some of the more powerful motors create a considerable torque effect; that is, a twisting motion causing the boat to ride with one sheer lower than the others. This twisting reaction is caused by the direction of propeller rotation lifting one side of the boat. This causes an uneven drag, so that a boat's bow may tend to fall off in one direction or the other from the intended course given by the wheel.

Good hull design offsets a majority of this tendency in SEA RAY® boats, but some torque action may occur when maximum or close to



maximum rated horsepower is applied. Any slight torque may be offset by shifting passenger or gear weight laterally to the high side of the boat.

**Replace Damaged Propellers:** Propellers should be free from nicks, excessive pitting and any distortions that alter the propellers from their original design.

Badly damaged propellers should be replaced. Those that are chipped, bent, or merely knocked out of shape can be reconditioned by your marine dealer. If damaged beyond repair, replace the malfunctioning propeller with a new one.

When doing extensive cruising, it is always advisable to carry an extra propeller aboard.

Operating your boat with a damaged propeller will reduce its top speed, may introduce undesirable handling characteristics, and will definitely increase fuel consumption.

A damaged propeller may also create unpleasant vibrations leading to an increased sound level. These excessive vibrations will hasten wear to rotating and reciprocating engine components and may cause costly damage.

## SEACOCKS AND STRAINERS

Seacocks and strainers are located in the bilge area. To open the seacock, loosen the wingnut at the bottom of the seacock then turn the permanently mounted handle vertically and tighten the wingnut. To close, loosen the wingnut, turn the handle horizontally then tighten the wingnut. **Do not over tighten.** The seacock body should be inspected and lubricated annually.

Sea water strainers should be inspected frequently and cleaned out when plugged. To clean the strainer, close the seacock and unscrew the wingnuts on top of the strainer housing. Remove and wash the stainless steel screen. After replacing the screen, replace the O-ring, replace and tighten the wingnuts, open the seacock and check for leaks.

**CAUTION: CLOSE ALL SEACOCKS WHEN LEAVING THE BOAT FOR ANY LENGTH OF TIME.**

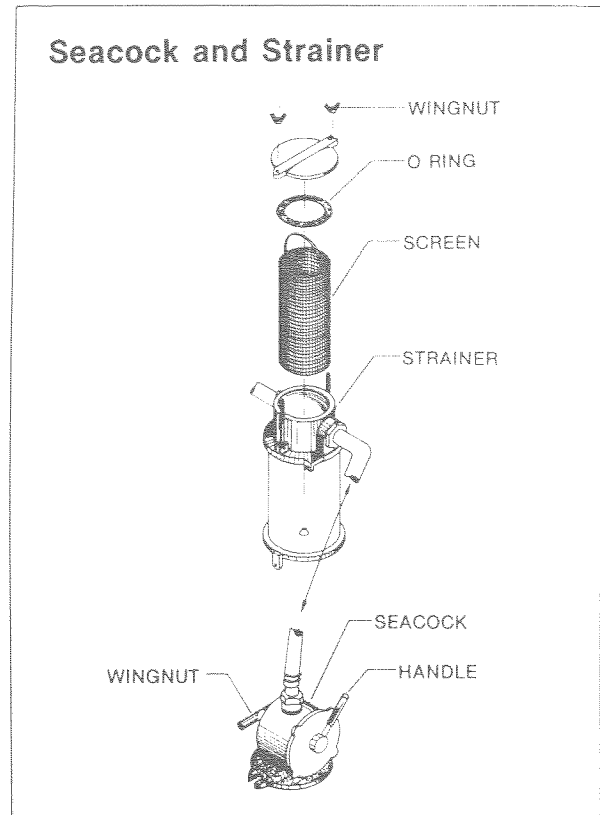

# Instruments And Controls

## 270 AMBERJACK, HARDTOP HELM & SPORTFISH

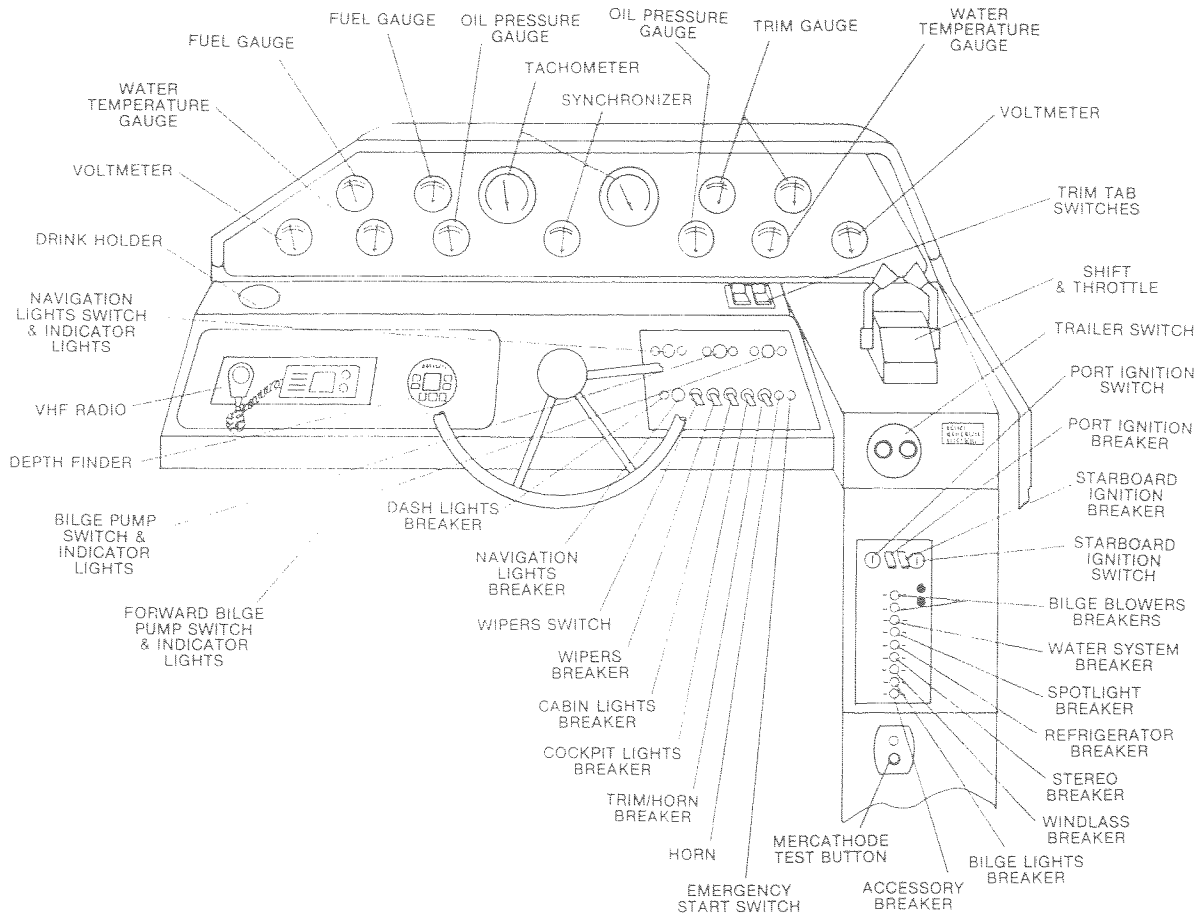

## 270 SUNDANCER® HELM

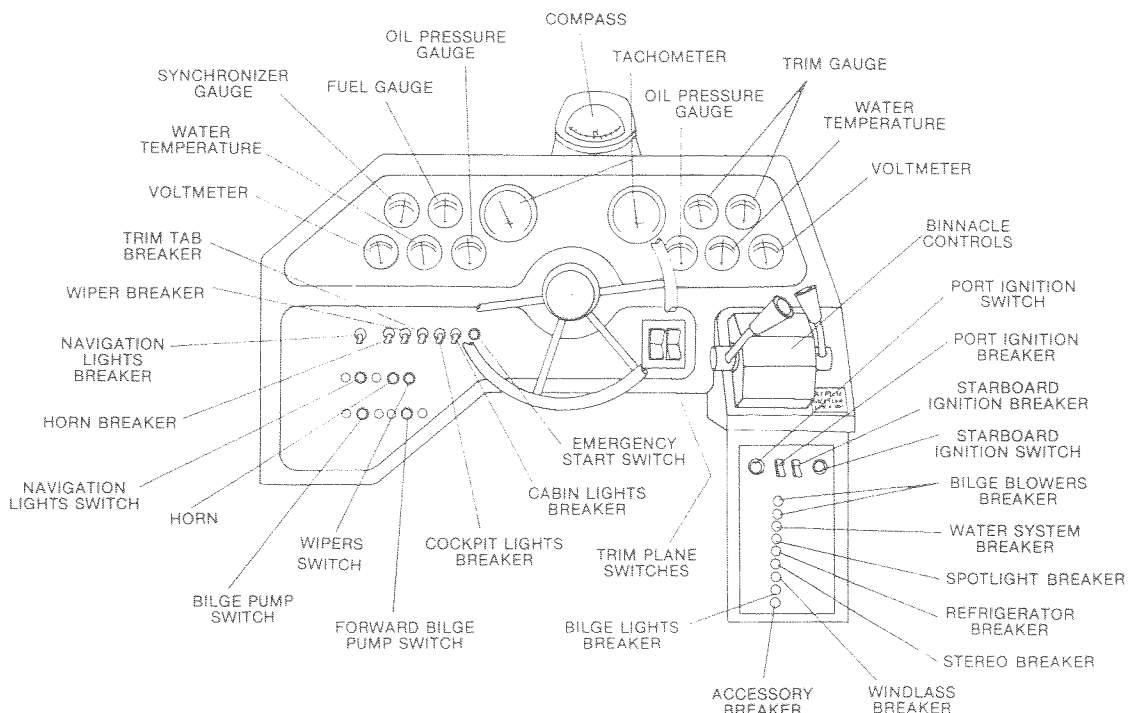

## 270 SPORTFISH BRIDGE OR UPPER HELM

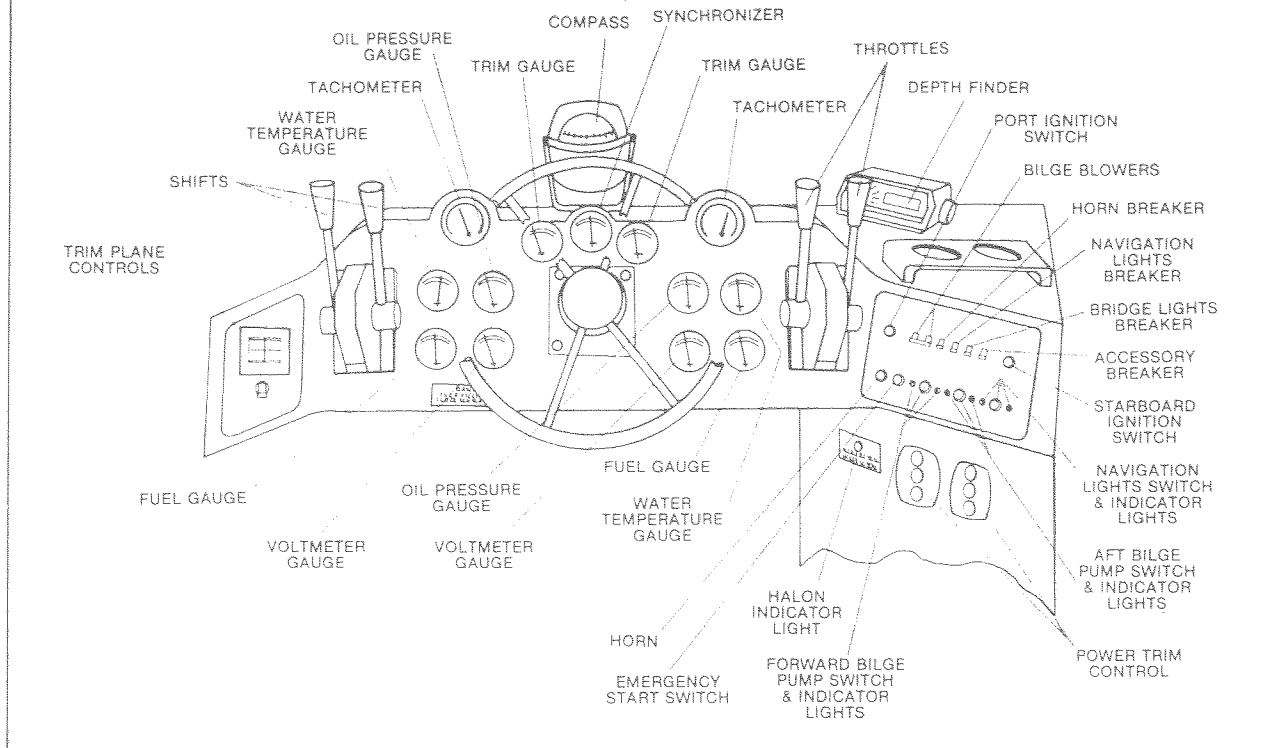

### STEERING SYSTEM

The standard power steering used on your SEA RAY® is a mechanical system with enclosed cable.

The steering wheel at the helm position is connected to the stern drive by cable. The cable connections at the helm and at the outdrive should be inspected and tightened at least twice a year. **A loose connection can result in sudden loss of steering and control.**

Push-pull cable steering should be checked for proper lubrication of the cable, proper alignment, with no binding or looseness, and no interference in the system. Cable and attachments to the stern drive should be checked for wear, rust or corrosion on a regular basis and be properly lubricated. Check the anchor post at the aft end of the cable to be sure it is secure and free from rust and corrosion.

Power steering must have lubrication and maintenance inspection at regular intervals as specified: under normal service — every 50 hours of operation or 60 days, whichever ever comes first; under severe service - every 25 hours of operation or 30 days, whichever ever comes first.

**NOTE: Operation in salt water is considered "severe service."**

Lubricate the control valve through the grease fitting with multi-purpose lubricant until grease appears around the rubber boot.

Coat power steering output shaft and exposed steering cable end with special lubricant. See engine manufacturer's manual.

Lubricate cable end guide pivot point with SAE 30W engine oil

Check power steering fluid level and add type "A" automatic transmission fluid as required to bring level up to "full" mark on the dipstick, which is attached to fill cap. Refer to engine manual.

Inspect all hydraulic lines and hoses as part of routine maintenance for leaks. Be certain that lines and hoses are free from friction and extreme heat and adjoining parts. Tighten fittings and clamps as needed.

Check all bolts for tightness on a regular basis.

Check pump pulley drive belt often for wear and proper tension. Overtight belts may cause bearing failure. Loss of the belt compounds effect steering severely.

SEA RAY recommends that all repairs and/or replacements to steering systems be made only by qualified dealers authorized by the

manufacturer of the steering system of your boat.

**CAUTION: Boat steering is not self-centering. Steering is affected by engine and propeller torque, trim tab setting, wave and current action, and the speed of the hull through the water. Constant attention and control of the direction of the boat is required for safe operation.**

## HYDRAULIC STEERING SYSTEM

Hydraulic steering is standard on the SPORT-FISH model. Periodic maintenance is suggested, by removing the plug in the helm and checking the oil level visually. On boats with an upper and lower control station, the oil level must be checked and oil added at the upper station. The oil level should be within 1/2" of the filler hole. A bottle of Aircraft Oil HO-15 is included with the system.

### Recommended Oils:

Seastar Hydraulic Oil by Teleflex  
Aircraft Oil HO-15 by Texaco

### Acceptable Oils:

Univis J-43 by Exxon  
Spinestic 10 by Texaco  
Spindura 10 by Texaco  
Spindale B by Amoco  
E.P. Machine by Chevron  
Veedol Hydro Trans 60 by Getty  
Velocite No. 6 by Mobil  
Gulf Spin 35 by Gulf  
Industron 34 by Standard/Boron

Periodically check the mechanical connections and linkages at the cylinder. Replace worn parts, tighten loose parts and lubricate as needed. Seastar steering systems are protected against over-pressure situations by a pressure relief valve. Sometimes when returning the wheel from a hard-over position, a slight resistance may be felt and clicking noise may be heard. This is a completely normal situation caused by the releasing of the lockspool in the system.

## GEAR SHIFTS AND THROTTLE CONTROLS

The control on your SEA RAY activates both the shifting mechanism and the throttle advance. The control must be in the neutral position to start your engine. Moving the lever forward engages the forward gear and then the throttle advance. To reverse power, bring the control lever back to neutral position, then move it further back to engage the reverse gear and increase reverse thrust.

A "Throttle Only" button is located in the base of the control lever and allows the shift mechanism to be disengaged from the throttles. This allows the throttle to be advanced without shifting the transmission when starting. (Button can be depressed only when control lever is in neutral.)

The throttle controls regulate the RPM of the engines. Regulating RPM of the engines will control the speed of the boat through the water.

Reversing the shift mechanism will act as a "braking action" when maneuvering the boat at low speeds. Care should be taken in using reverse throttle for "braking action," as sudden slowing of the boat from forward motion will create a following wake which may rise above the transom and flood the boat if the boat is moving at too great a speed. All propellers are designed to provide maximum forward thrust, so the reverse thrust of the propeller will not be as efficient.

Controls may vary slightly depending on the particular SEA RAY model and engine combination.

## 270 SPORTFISH ONLY

The electric gear shift lever for each engine has three positions: forward, neutral (center), and reverse (aft). The control lever must be in the neutral (center) position when starting the engine. A positioning pin can be felt when the control is in exact neutral. Forward and reverse positions should always be in the full travel extremes in either direction for positive engagement and minimum wear.

The throttle controls regulate the RPM of the engines. Periodically check and seasonally lubricate the linkages with a medium weight oil.

REFER TO OWNER'S PACKET.

## POWER TRIM OPERATION

The Power Trim System allows the operator to raise and lower the drive unit for trailering, beaching, launching, and shallow water operation. Power Trim also allows the operator to adjust the angle of the drive unit while underway, to provide the ideal boat angle (in relation to the water surface) for a given load and water condition. In most cases, best all around performance is obtained with the drive unit adjusted so that the boat will run at a 3° - 5° angle to the water (front of hull just slightly out of the water).

### Moving Bow "Up" (Drive Unit "Up") Characteristics:

- Reduces wetted surface of hull, generally increasing top speed.
- Increases clearance over submerged objects.
- May cause boat to accelerate and get up on plane slower.
- In excess, can cause bouncing, porpoising, and/or propeller ventilation.

### Moving Bow "Down" (Drive Unit "Down") Characteristics:

- Will help boat to accelerate and get up on plane faster.
- Could improve boat ride in rough water (at partial throttle).
- Will reduce boat speed in most cases.

### To Raise Drive Unit for Trailing, Beaching, Launching, or Shallow Water Operation:

- Press "Trailer" switch until drive unit reaches desired height or end of upward travel.

**NOTE:** *Power Trim pump motor is protected from overheating by an internal circuit breaker. If trailing switch is held depressed after drive unit reaches end of upward travel, internal circuit breaker will open and pump will stop. It this should happen, release switch and allow motor to cool for approximately one minute. Once motor is cool, circuit breaker will reset automatically and trim operation may be resumed.*

**CAUTION: DO NOT** run engine above 1200 RPM with drive unit raised for shallow water operation, as drive unit is out beyond gimbal ring support flanges and has no side support. **USE EXTREME CAUTION WHEN OPERATING BOAT WITH DRIVE UNIT RAISED.**

### To Trim Bow of Boat "Up" (Drive Unit "Up"):

- Press "Up" on "Trim" switch until the drive unit moves to properly trim the boat or until trim limit switch stops outward travel.

**CAUTION: NEVER** trim the drive unit "out" (bow of boat "Up") using the "Trailer" switch while boat is underway. Severe damage to drive unit may result if the unit is raised beyond the gim-

bal ring support flanges at engine speeds above 1200 RPM.

### To Trim Bow of Boat "Down" (Drive Unit "Down") or to Lower Drive Unit from Raised Position:

- Press "Down" on "Trim" switch until the drive unit moves to properly trim boat or until the drive unit reaches the end of downward travel.

FOR DETAILED OPERATING INSTRUCTIONS REFER TO ENGINE OPERATOR'S MANUAL IN THE OWNER'S PACKET.

## IGNITION SWITCH

The ignition switch on your boat has three positions - "off," "on" and "start." The "start" position is spring loaded and the key should be held in this position until the engine starts. After the engine starts, release the key and it will return to the "on" position. Always turn the key to the "off" position when the engine is not running to prevent discharging the battery. ***Do not operate the engine starter motor for more than 15 seconds at one time as the motor will overheat.***

## SYNCHRONIZER

The synchronizer gauge indicates which engine is running slower by the needle registering to the slower engine. To synchronize the engines, adjust the engine RPM with the throttles until the needle is centered in the gauge.

The engine synchronizer is designed to operate between 1500 and 4200 RPMs. When engines are not under load and running in neutral gear, they will tend to surge and indicate out of synchronization very easily.

## TACHOMETER

The tachometer indicates the revolutions per minute (RPM) of the engine. It does not indicate the speed of the boat through the water or over the bottom.

## OIL PRESSURE GAUGE

Very little serious trouble can occur in an engine which will not be reflected on the oil pressure indicator. Maximum pressure is controlled by a pre-set valve in the oil pump. Note the reading which this gauge records when the engine is new, as it is the "norm" which can be used as reference during the life of the engine.

**IF A COMPLETE LOSS OF OIL PRESSURE OCCURS, TURN THE ENGINE OFF AT ONCE.** Continued running after loss of pressure will cause engine damage. First, manually check the oil level. If low oil level is not the cause, consult your SEA RAY® dealer. **DO NOT RESTART THE ENGINE UNTIL THE PROBLEM HAS BEEN CORRECTED.**

Slight fluctuations in gauge readings are not uncommon during operation and may be due to the characteristics of the lubricating oil. Greater fluctuations should be investigated. The cause may be a clogged oil filter element which should be replaced with every oil change.

### TEMPERATURE GAUGE

The temperature gauge indicates the cooling water temperature inside the engine. Marine engines draw external water, circulate it through the heat exchanger on the engine and expel it overboard through the exhaust system.

### VOLTMETER

The function of the voltmeter is to indicate battery voltage. Normal engine operating voltage will range between 12.0 to 15.5 volts when the alternator is charging. Significantly higher or lower readings indicate a battery problem, alternator malfunction or heavy battery drain.

REFER TO YOUR ENGINE OPERATOR'S MANUAL FOR PROPER GAUGE READINGS.

### FUEL GAUGE

The two fuel gauges indicate the amount of fuel in the port and starboard tanks respectively. Because gauge readings are approximate, they should be compared to the hours of use versus known fuel consumption (GPH).

### HOURLY METER

The hour meters measure cumulative hours of operating time and are available for both engines and the generator. They should be used to keep a careful log of engine maintenance

as well as performance data and fuel consumption. Do not leave the ignition key on with the engines off, as this will increase the engine hours on the hour meter.

### TRIM PLANES

The trim planes on your SEA RAY boat are operated with a rocker type momentary switch on the dash. They are protected by a 20 amp circuit breaker on the dash panel which must be on to use the trim planes (tabs).

To trim the bow of your boat down, push the top halves of both rockers down in half second bursts. If you hold the rockers down, you will over trim the boat and the bow will dig in. To correct over trimming, push the bottom halves of both rockers to obtain the desired planing angle.

The two trim planes on the transom of your boat can also be used to trim the list of your boat that may be caused by improper storage of gear, too many people on one side or a strong crosswind. Operation of the rocker switch should be momentary short bursts to achieve proper attitude of the hull.

When running wide open, most boats do not require any trim unless heavily loaded.

In heavy following seas or when running in an inlet best maneuverability is obtained with a bow high attitude. To be sure the planes are full up in the zero position, push the bottom halves of the rockers for several seconds.

The trim plane pump is located in the bilge, mounted on the transom. Access to the pump is through the aft cockpit hatch. To service the unit, remove the tinted plastic cover to gain access to the reservoir fill plug and motor parts. Hydraulic trim planes use Type A Dextron II automatic transmission fluid, which should be filled up the "full" mark on the pump base. **Add fluid with the trim planes in the up position only.**

REFER TO OWNER'S PACKET.

<b>RUNNING ATTITUDE</b>	<b>LIST</b>	<b>PUSH</b>
BOW UP	----	TOP OF BOTH ROCKERS
BOW UP	PORT	TOP OF STARBOARD ROCKER
BOW UP	STARBOARD	TOP OF PORT ROCKER
BOW DOWN	PORT	BOTTOM OF STARBOARD ROCKER
BOW DOWN	STARBOARD	BOTTOM OF PORT ROCKER

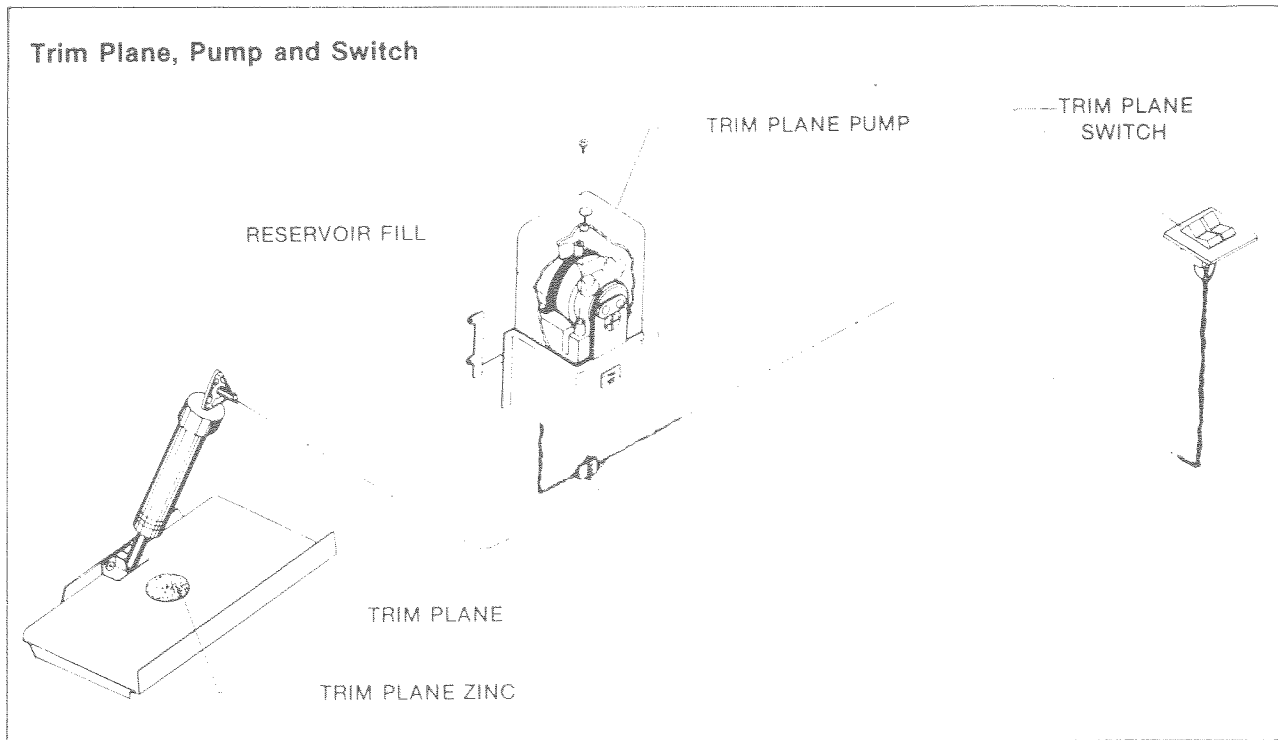

## MARINE COMPASS

A marine compass is deflected and its usefulness impaired when other instruments or objects containing iron, magnets, or electric current carrying wires are in its vicinity. A newly installed compass must be adjusted to compensate for these influences if they must remain in proximity to it.

The compensating or adjusting should be done by a qualified compass adjuster. A compass can seldom be corrected to zero deviation on all headings, so you will be provided with a deviation card or chart showing the correction to be applied when laying out a compass course or making your navigational calculations. **Keep this card at the helm at all times.**

After your compass is adjusted, do not permit items such as iron or steel to be placed near it, even temporarily, as they will affect its accuracy. The compass must be readjusted if any items which affect it are removed, relocated or added in its vicinity.

When not in use, the compass should be protected from excessive and prolonged sunlight. If your compass becomes sluggish or erratic, it should be serviced by an authorized repair station.

Your compass is equipped for night use with a 12 volt light that turns on with the navigation lights breaker.

To keep the plexiglass dome free from scratches, remove salt deposits and dust with a damp cloth. An occasional treatment with paste wax will help preserve the dome surface.

REFER TO OWNER'S PACKET.

## LOWER CONTROL STATION

The lower control station on the 270 SPORT-FISH allows operation from the cockpit of the boat. Full steering, shift and throttle controls are installed. With the lower trim plane and spotlight controls, all equipment functions are usable from the lower station. The lower helm has master ignition key switches. To turn off engines, the master ignition key switches must be turned "OFF".

## Fueling Precautions

Certain precautions must be carefully and completely observed every time a boat is fueled, even with diesel fuel. Diesel fuel is non-explosive but it will burn.

### **Before Fueling:**

- Make sure your boat is tied securely to the fueling pier.

- Turn off engines, engine blowers, fans and other devices that can produce a spark.
- Close all windows, doors and hatches to prevent fumes from entering the boat.
- Disembark all people not needed for the fueling operation.
- Prohibit all smoking on board and nearby.
- Have a fire extinguisher close at hand.

#### While Fueling:

- Do not leave boat unattended.
- Keep nozzle or can spout in contact with the fill opening to guard against static sparks.
- Do not spill fuel.
- Do not over fill. Filling a tank until fuel flows from the vents is dangerous. Allow room for expansion.

#### After Fueling:

- Close fill openings.
- Wipe up any spilled fuel. Dispose of wipe up rags on shore.
- Open all windows, doors and hatches; turn on bilge blowers. Ventilate the boat for at least four minutes.
- Check for fuel fumes in the bilge; continue ventilation until odor can no longer be detected. Check for any drips or liquid fuel.

---

## Starting Engines

---

- (1) Check the fuel tank levels.
- (2) Check the oil and coolant levels. See your Engine Operator's Manual for proper readings.
- (3) Check engines for coolant drain plug installations.
- (4) Check fuel filters for tightness.
- (5) Check fuel valves. (Diesel only)
- (6) Run the bilge blowers at least four minutes. Check the bilge for fuel fumes or liquid. Do not start the engines until the source of fumes is determined and cor-

rected and the bilge area is safely ventilated.

- (7) Turn ignition breakers and keys "on." Listen for alarm buzzers which indicate ignition power.
- (8) After ignition power is verified, check shift for neutral position and turn key switch up to start position and release after engine starts. Do not operate the starter for more than 10 seconds without allowing the starter to cool off for 2 minutes. This will also allow the batteries to recover between starting attempts.

**Important:** Check engine RPM on tachometer as soon as engines start. Do not allow RPM to exceed 1500. Move throttle levers down to decrease RPMs.

- (9) Check the oil pressure.
- (10) Let the engines warm up at idle and check for leaks. If engine is cold, run for a short period of time at fast idle speed that does not exceed 1500 RPMs.

- (11) Shut down the engines and recheck fluid levels; top off if necessary.

Move shift lever forward to shift into "forward" gear or backward to shift into "reverse." Always shift gears with engine idling.

**NOTE:** For general operation of the boat, its instruments and the engine, follow detailed instructions on "engine break-in" in the Engine Operator's Manual.

---

## Water Systems

---

The fresh water system is activated by a 15 amp circuit breaker on the helm switch panel. The breaker must be on to operate the head, shower, fresh water wash down or faucets. To begin initial operation, fill the tank with water and open all faucets, both hot and cold. Turn the water system breaker on. Allow time for hot water heater to fill. Shut off each faucet as flow becomes steady and free of air. Shutting off the last faucet should cause the pump to shut off.

### WATER TANK

The water tank on the 270 HARDTOP, AMBER-JACK and SPORTFISH has a 28 gallon capacity and is located below the center forward cockpit hatch.



The 270 SUNDANCER® has a 28 gallon capacity and is located below the forward port cockpit hatch. When the 270 SUNDANCER comes with a generator or SanX Sanitation System the water tank is located in the bow under the forward berth cushions.

The water tank is filled through the deck fill plate on the port deck walkway. When the SUNDANCER has the bow located water tank, the fill plate is located on the starboard bow.

Fill the tanks only from sources known to provide safe, pure drinking water.

To check the water level in the tanks, hold the water level switch on the main distribution panel toward "water level." The lights will indicate the amount of water in the tanks.

Although your dealer initially sanitizes the water system, if the system has not been used for a long period of time or you suspect it may be contaminated, adhere to the following procedure for complete sanitation of your potable water system.

- (1) Prepare a chlorine solution using one gallon of water and 1/8 cup Clorox or Purex household bleach (5% Hypochloride solution). With tank empty, pour chlorine solution into tank, using one gallon solution for each 15 gallons of tank capacity.
- (2) Complete filling of tank with fresh water. Open each faucet and drain cock until air has been released and the entire system is filled.
- (3) Allow to stand for three hours.
- (4) Drain and flush with potable fresh water.
- (5) To remove excessive chlorine taste or odor which might remain, prepare a solution of one quart vinegar to five gallons water and allow this solution to agitate in the tank for several days by vehicle motion.
- (6) Drain tank and again flush with potable water.

## 270 Water Systems

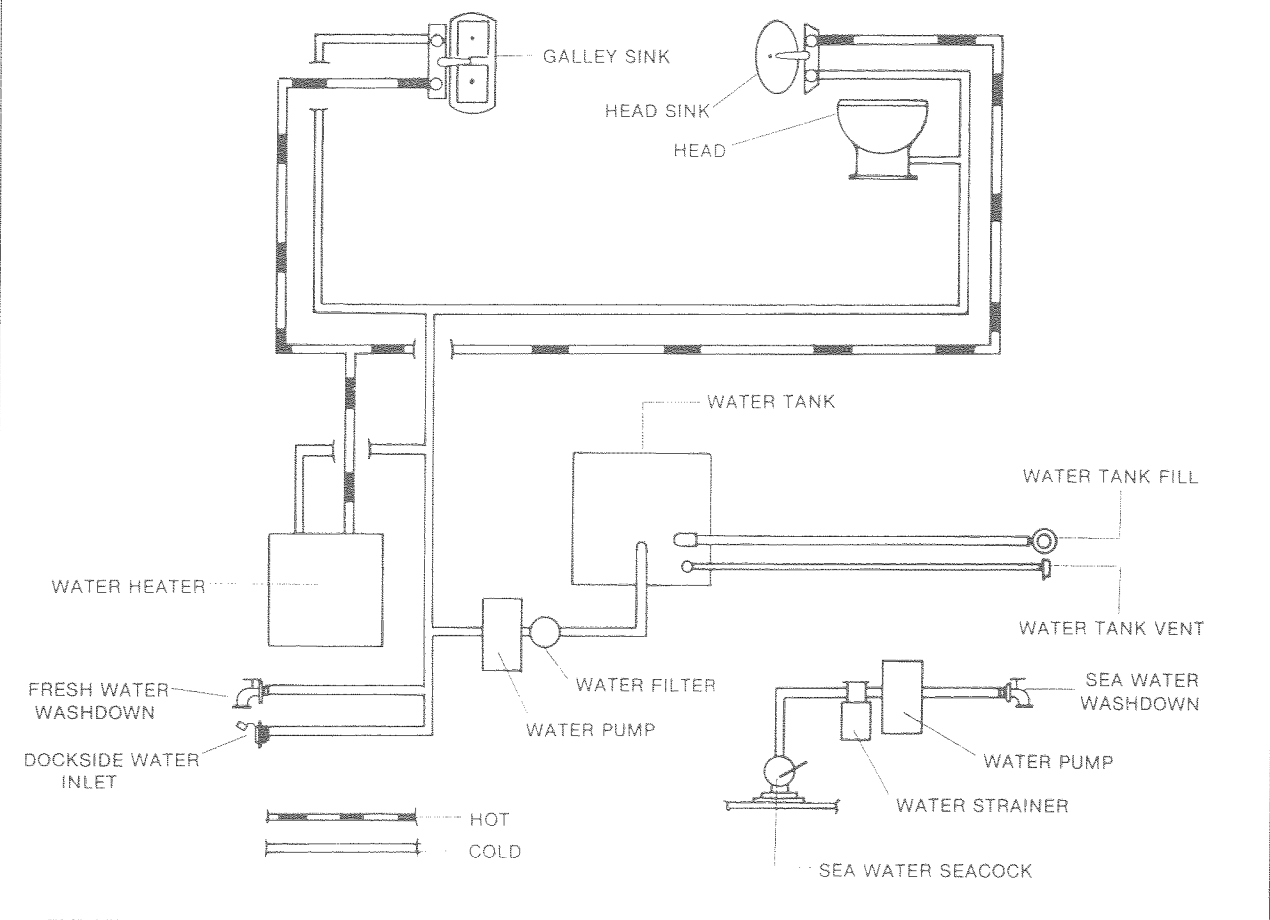

## WATER PUMP

The water pump for the fresh water system is located adjacent to the water tank. A filter prevents particles from entering the pumphead. It should be checked and cleaned periodically.

Before servicing the system, turn off the water system breaker and release pressure on the system by opening faucets. To clean, remove the screw in the top of the filter case and remove the screen. Rinse the screen out with clean water. Make certain the "O" ring is in place when replacing the cover.

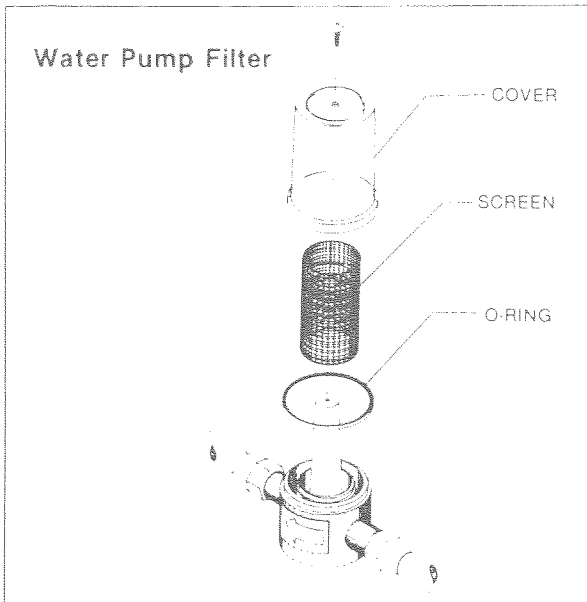

## WATER HEATER

The water heater is located in the forward port side of the bilge. Access is through the cockpit hatch.

The water heater has a 6-gallon capacity and runs on 110-volt dockside power or generator and also on the engine cooling water and has a 15 amp circuit breaker on the main distribution panel. The water heater has a check valve to prevent hot water from backwashing into the cold water source and a pressure relief valve to avoid damage to the heater from over pressure or too high a temperature. **Note: The thermostat is preset and is not adjustable.**

### *Initial Start-Up Or After Winterization:*

- (1) Make sure the water heater breaker is off.
- (2) Fill the heater with water.
- (3) Open the hot water faucets until all air is eliminated from the system.

- (4) Make certain the heater is full of water and that the cold water inlet valve is open. **COMPLETE FAILURE OF THE HEATING ELEMENTS WILL RESULT IF THEY ARE NOT COMPLETELY IMMERSSED IN WATER AT ALL TIMES.**

- (5) Turn the 110 volt breaker "on".

To maintain the water heater properly, drain whenever the possibility of freezing occurs and frequently inspect the lines and connections for leaks.

REFER TO OWNER'S PACKET.

## SHOWER SYSTEM

The shower is a hand-held unit that attaches to the head sink faucet. When in use, mount the unit on the white peg on the forward bulkhead. Water from the shower drains into the forward bilge sump.

After using the shower, it is recommended that you run a gallon of clean water through the shower drain to clean out soap residue. A plastic roll-down shower curtain is provided to protect the door and prevent water seepage.

## FRESH WATER WASHDOWN

The freshwater washdown spigot is located near the floor on the port side of the cockpit. The water for this system comes from the fresh water tank and the water system breaker on the helm switch panel must be on to operate it.

## Head Systems

### RECIRCULATING HEAD PUMP OUT

The portable head with dockside pump out is a portable self-contained unit and has two individual holding tanks.

The top tank is fitted with a hand pump and has a 3½ gallon capacity for fresh water and chemicals. The bottom tank is for holding waste material and has a 5 gallon capacity. There is a dockside pumpout hose attached which leads to a waste plate on the starboard side of the deck.

The holding tank can be emptied by a dockside sewage pump out station. Remove waste plate

cap and insert vacuum hose from pump out station. Activate pump out station.

If you have the macerator option it and the Y-Valve would be located under the vanity in the head. The Y-Valve setting determines the direction of the waste from the holding tank, either to the dockside pump out or to the macerator.

The macerator is operated by the switch located in the head. When activated, waste from the holding tank is pumped through the macerator where it is processed before being discharged overboard.

### MANUAL FLUSH HEAD WITH HOLDING TANK OPTION

This head option offers a porcelain head with a 10 gallon holding tank. To operate the manual flush head, move valve lever to "wet bowl" open position and operate pump handle to pump water into bowl. Return valve lever to "dry bowl" closed position and operate pump handle until bowl has been cleared.

Waste from the head is directed into the holding tank. There is an indicator panel in the head indicating "¾ Full," "Full" and "Do Not Flush." When the "Full" light is on, the "Do Not Flush" light will also be on. The holding tank must be emptied before the head can be reused.

To empty the holding tank the services of a dockside pump out station will be needed.

### VACU-FLUSH HEAD

The Vacu-Flush head is available with a holding tank or the San X One system and utilizes a 15 amp "head system" breaker on the main distribution panel. The foot pedal at the base of the toilet opens a mechanical seal and the vacuum forces waste through the opening in the bowl to an accumulator tank, through the vacuum pump and then to the holding tank or treatment tank.

When boat is equipped with the macerator option there will be a switch located in the head which operates the macerator.

The macerator is equipped with a Y-Valve which is located near the holding tank. The Y-Valve setting determines the direction of waste from the holding tank, either to the dockside pump out or to the macerator. When activated, waste from the holding tank is pumped to the

macerator where it is processed before being discharged overboard.

#### **To Operate:**

- (1) Turn on the "Water System" breaker.
- (2) Turn on the "Head System" breaker and the "Treatment System" breaker if boat is equipped with the San X One treatment system.

**WARNING: DISCHARGE OF SEWAGE DIRECTLY OVERBOARD IS FOR USE WHERE APPROVED ONLY.**

### SAN X ONE TREATMENT SYSTEM

The San X One system utilizes a 15 amp head breaker and a 15 amp holding tank system breaker located on the main distribution panel.

There is an indicator panel in the head indicating "¾ Full," "Full" and "Do Not Flush." When the "Full" light is on, the "Do Not Flush" light will also be on. The treatment tank must be emptied before the head can be reused.

With the San X One system waste is held in the holding tank and treated in a bacteria controlling solution while being processed by a macerator. The waste can either be held in the holding tank for later discharge or immediately discharged after treatment.

If waste is to be discharged, make certain overboard discharge seacock is in the open position. It has a 3-position control switch on the main distribution panel with the following modes:

**Normal:** Waste is held in treatment tank.

**Treat and Hold:** Chemicals are injected and the 20-minute treatment cycle starts. Upon completion of cycle, waste is held in tank.

**Treat and Discharge:** Injects chemicals into the tank and starts the 20-minute treatment cycle. When the cycle is complete, waste is automatically discharged. Make certain overboard discharge seacock is in the open position.

After the tank is emptied, a pint of bacteria-controlling chemical is automatically pumped into the tank. Approximately one gallon of treatment chemical is required for four treatment cycles.

#### **For Normal Operation:**

- (1) Turn on the "Water System" breaker.

- (2) Turn on the "Head System" breaker and the "Treatment System" breaker.
- (3) Set San X control switch to "Normal" position.

**For Treatment Operation:**

- (1) Turn on "Treatment System" breaker.
- (2) Select "Treat and Hold" or "Treat and Discharge" functions on San X control panel.

REFER TO OWNER'S PACKET.

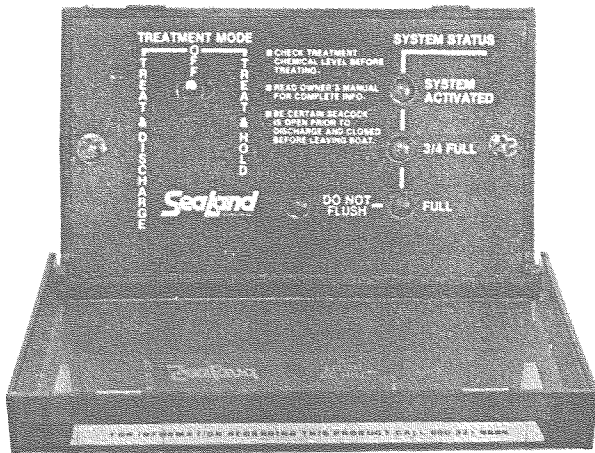

*San X One Control Panel*

# Section 3

## ELECTRICAL SYSTEMS

### D.C. Systems

The 12-volt direct current (D.C.) electrical system derives its power from the batteries, which are kept charged by an engine-driven alternator and an A.C. converter. The battery charge is indicated by the voltmeter on the dash panel. The batteries supply power through the circuit breakers in the bilge breaker boxes then to the dash and main distribution panel. The D.C. circuit breakers on the dash panels and main distribution panel have green indicator lights and operate all 12-volt accessories onboard.

The negative terminal of each bank of batteries is attached to the grounding studs of the propulsion engines and the generator. This "negative ground system" is the approved system for marine D.C. electrical systems. Additional equipment must be adaptable to the negative ground system, and when installing, it will be necessary to stipulate that each item's current supply be taken from the main distribution panel. If additional circuit protection is required, it should be added in that area. Do not allow any power feeds for accessory equipment to be taken from the voltmeter terminals.

Enlist the aid of your dealer for a careful analysis of D.C. power needs on your boat. It may be necessary to add batteries or auxiliary charging methods to supply adequate power for the additional accessories you require.

### BATTERIES

The batteries provided have been selected for their ability to furnish starting power based on engine starting requirements.

The batteries are sealed using an absorbent electrolyte principle and offer high reserve capacity and cold cranking performance. Other features of these batteries are no leakage or acid spills, no water addition, no corrosion and reduced damage caused by overcharge.

A low-voltage battery (9 volts rather than the nominal 12 volts) will not actuate the voltage regulator even though it might start the engine. Consequently, the alternator cannot deliver a charge to the battery, and it will be necessary to have it recharged ashore.

**ALWAYS DISCONNECT THE BATTERY CABLES BEFORE DOING ANY WORK ON THE ENGINE'S ELECTRICAL OR ALTERNATOR WIRING TO PREVENT SPARKING OR DAMAGE TO THE ALTERNATOR.**

#### *To remove the battery cables:*

- (1) Turn off all items drawing power from the batteries.
- (2) Turn off the converter breaker.
- (3) Turn off battery switches.
- (4) Remove the positive cable first, then the negative cable. To replace the cables, reverse the procedure.

**ANY ACID SPILLED ON THE BATTERIES, BATTERY BOXES OR OTHER PARTS SHOULD BE NEUTRALIZED AND CLEANED UP WITH BAKING SODA AND WARM WATER.** The terminals and clamp bolt nuts should be cleaned in the same manner. The battery manufacturer recommends that the terminal and battery tops be coated with marine corrosion inhibitor CRC or an equivalent as a corrosion preventative.

Batteries in storage or idle for months at a time should be kept under trickle charge or should be fully charged once a month.

Recheck battery terminals for tightness and never disconnect under load.

**NEVER USE AN OPEN FLAME IN THE BATTERY STORAGE AREA.**

**AVOID STRIKING SPARKS AT THE TERMINALS.**

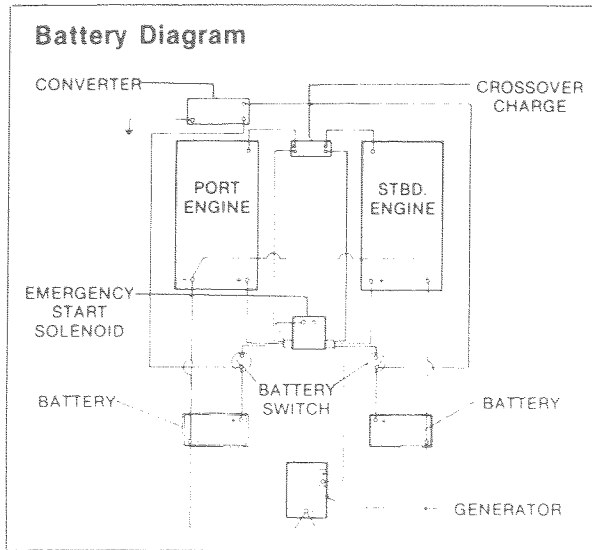

## BATTERY SWITCHES

The battery switches are located forward of the engine on the center liner brace. Each switch handles its own bank of batteries. They must be on to start the engines or the generator. **CAUTION: ALWAYS STOP ENGINES BEFORE SWITCHING TO THE OFF POSITION.**

## EMERGENCY START SYSTEM

The emergency start switch is a momentary toggle switch located on the dash next to the ignition switches which parallels the batteries to assist in starting. Use the emergency start when the charge of one bank of batteries is insufficient to start the corresponding engine. Activate the emergency start switch before the ignition switch.

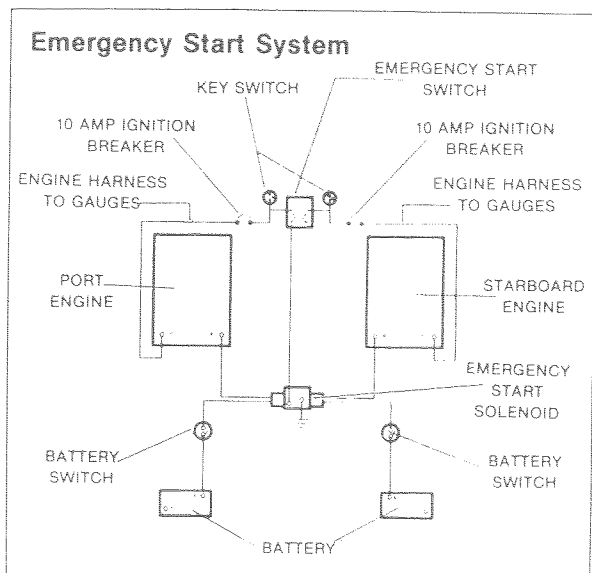

## CROSSOVER CHARGING SYSTEM

The crossover charging system utilizes a battery isolator unit with an electronic sensor to determine a low battery bank and send power to it from the engine alternators. It is an automatic system with no switches, and designed to charge both banks of batteries from both engine alternators, when necessary. The isolator is located in the bilge on the port side of the transom.

## BILGE BREAKER BOX

The breaker box is located on the forward starboard side of the bilge. The breaker box has three 10 amp breakers, two for the bilge pumps and one for the emergency bilge pump, and two 50 amp breakers, one for the helm switch panel and one for the electronics circuit fuse block behind the dash.

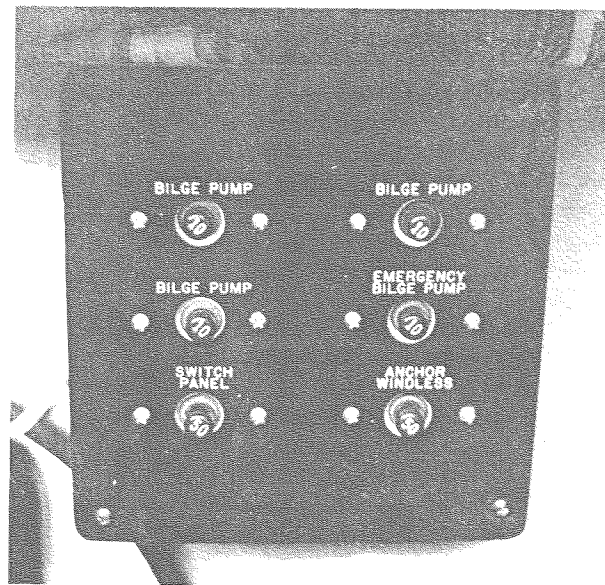

*Bilge Breaker Box*

## ELECTRONICS CIRCUIT WITH GROUND PLATE

The 50 amp electronics circuit utilizes a circuit breaker in the lower bilge breaker box to feed a fuse block located behind the dash on the SUNDANCER®, AMBERJACK and HARDTOP, and behind the upper helm on the SPORTFISH model. **The fuse block is to be used for electronic equipment only.** The circuit is grounded via a ground plate mounted on the bottom of the hull. **Do not use bottom paint on the ground plate as it will destroy the effective area of grounding.**

## 12 VOLT BREAKERS

BREAKER	AMPS
<b>HELM BREAKERS</b>	
IGNITION	10
IGNITION	10
BLOWERS (EACH)	10
WATER SYSTEM	15
SPOTLIGHT	10
REFRIGERATOR	20
STEREO	10
WINDLASS	30
BILGE LIGHTS	10
ACCESSORY	5
NAVIGATION LIGHTS	10
HORN	10
TRIM TABS	20
COCKPIT LIGHTS	10
CABIN LIGHTS	20
TRIM/HORN*	20
WIPERS	10
VENTS	20
HEAD	20
<b>BRIDGE HELM BREAKERS*</b>	
TRIM TABS	20
BLOWERS (EACH)	10
HORN	10
NAVIGATION LIGHTS	10
BRIDGE LIGHTS	5
ACCESSORY	5

\*SPORTFISH ONLY

## WIRE COLOR CODE

### • BATTERY WIRING

#### 2/0 (Diesels Only)

- 2 AWG Red, battery cable (positive)
- 2 AWG Black, battery cable (negative)
- 2 AWG Red, generator power (positive)
- 2 AWG Black, generator ground (negative)
- 8 AWG Red, crossover charge
- 16 AWG Red, emergency start
- 10 AWG Red, ignition switch

### • BILGE BLOWERS/POWER VENTS

- 16 AWG Yellow, blower motor power
- 16 AWG Black, ground

### • BILGE/SHOWER PUMPS

- 16 AWG Brown/Yellow, auto mode (Forward Pump)
- 16 AWG Brown/Gray, auto mode (Aft Pump)

- 16 AWG Brown, auto mode
- 16 AWG Brown, manual mode
- 16 AWG Black, ground
- 16 AWG Brown, bilge high water alarm

### • CONVERTER

- 8 AWG Red, power
- 8 AWG Black, ground
- 12 AWG Black-romex, 110 AC hot
- 12 AWG White-romex, 110 AC neutral
- 12 AWG Green-romex, bonding system

### • ENGINE HARNESS

- 16 AWG Blue, oil pressure sender
- 16 AWG Blue/Brown, alarm sender
- 16 AWG Gray, tachometer sender
- 16 AWG Brown, temperature sender
- 16 AWG Purple, ignition
- 16 AWG Yellow/Red, start circuit
- 16 AWG Red, engine hot
- 10 AWG Black, engine ground

### • HALON SYSTEM

- 10 AWG Red, power
- 10 AWG Black, ground (through switch on halon)
- 16 AWG Purple, engine shutdown (Diesel Only)

### • HOLDING TANK SYSTEM

- 16 AWG Blue, "full/do not flush"
- 16 AWG Yellow, "3/4 full"
- 16 AWG Red, power

### • LIGHTS

- 16 AWG Gray, running lights & mast light
- 16 AWG Gray/Red, anchor light
- 16 AWG Blue/White, cabin light circuits
- 16 AWG Blue, cockpit lights

### • ONAN GENERATOR

- 16 AWG Red, power
- 16 AWG Yellow, start
- 16 AWG Brown, "on" light
- 16 AWG Orange, preheat
- 16 AWG Black, stop
- 16 AWG Brown/Red, Halon (Diesel Only)

### • WESTERBEKE GENERATOR

- 10 AWG Red, power
- 10 AWG Red/Violet, start
- 10 AWG Green, preheat
- 16 AWG Orange, preheat
- 16 AWG White, stop
- 16 AWG Brown/Red, Halon

### • WINDLASS

- 8 AWG Red, power
- 8 AWG Black, ground (motor)
- 16 AWG Purple, fused hot
- 16 AWG Red, solenoid feed
- 16 AWG Red, down
- 16 AWG Red, up
- 16 AWG Black, ground solenoid

- **WIPERS**
  - 16 AWG Orange/Green, starboard wiper
  - 16 AWG Orange/Red, port wiper
  - 16 AWG Orange, wiper motor power
  - 16 AWG Black, ground
- **WATER SYSTEM**
  - 16 AWG Brown/Red, pumps
  - 16 AWG Black, ground, empty indicator light
  - 16 AWG Green,  $\frac{2}{3}$  level indicator light
  - 16 AWG White,  $\frac{1}{3}$  level indicator light
- **SAN X SYSTEM**
  - 10 AWG Red, discharge pump
  - 10 AWG Green, macerator
  - 10 AWG Black, ground
  - 16 AWG White, chemical pump
  - 16 AWG White/Blue, "full" indicator light
  - 16 AWG Yellow, "
  - 16 AWG Black, ground
- **SAN X CONTROL**
  - 16 AWG Red, treat and hold
  - 16 AWG Black, treat and discharge
  - 16 AWG Orange/Black, power positive
  - 16 AWG Brown/White, power negative
  - 16 AWG White, power
  - 16 AWG Blue, "do not flush"
  - 16 AWG Green, " $\frac{3}{4}$  full"
  - 16 AWG Orange, "full"
- **TRIM TABS**
  - 10 AWG Red, power
  - 16 AWG Red, port valve
  - 16 AWG Green, starboard valve
  - 16 AWG Blue, pump pressure
  - 16 AWG Yellow, pump retract

## A.C. Systems

The A.C. electrical systems operate off the standard dockside 30 amp 110 volt, 60 cycle shore power system or the onboard generator. The main distribution panel is equipped with a rotary transfer switch to select the power source. The system includes a 50-foot shore power cord, a 30-amp main breaker and a 30-amp air conditioner breaker.

**CAUTION: THE TOTAL USAGE OF OPTIONS WILL DEPEND ON THE AMP OUTPUT OF THE POWER SOURCE AVAILABLE.**

The system circuit breakers are equipped with amber indicator lights on the main distribution panel. The line voltage from the generator or shore power is shown by the voltmeter on the

main distribution panel. The ammeters indicate the amperes being drawn through the circuit breakers.

**CAUTION: NEVER OPERATE SHORE POWER AT LESS THAN 105 VOLTS.**

The wiring installed on SEA RAY® boats consists of three color-coded wires. The black wire is the "hot" feed, the white is the common, or neutral, and the green wire is the ground. All distribution breakers and switches for A.C. equipment are installed on the "hot" wire. A circuit breaker is placed on both the white neutral feed and the hot feed wire from shore power inlets. The green conductor of the shore power is connected to the ground buss bar behind the main distribution panel. The main breaker will trip if there is 1) a reversed shore power connection, 2) a surge in line voltage, or 3) an electrical storm, or 4) an onboard system overload. The main breaker protects the A.C. circuit from damage and should be checked after storms and surges.

### Shore Power Hook-Up:

- (1) Make sure the main breaker and all A.C. breakers on the main distribution panel are off.
- (2) Plug the shore power cord into the inlet on the side of the deck; turn clockwise to lock. Thread the black locking ring on the inlet to secure the cable and prevent accidental unplugging.
- (3) Plug the dockside cord into the shore power outlet box on the dock. Turn the circuit breaker on the dock to the "ON" position.
- (4) Check the polarity lights on the main distribution panel. The "NORMAL" lights should be on. If the "REVERSED" lights are on, check the dockside power for a reversed connection or reversed wiring.
- (5) If polarity is "NORMAL", turn the rotary switch on the main distribution panel to "Shore".
- (6) Turn individual breakers on.

### Maintenance for Shore Power Cable Set & Shore Power Inlets:

The metallic parts of your cable set and inlet are made to resist corrosion. In salt water environment, life of the product can be increased by periodically wiping the exposed parts with fresh water, drying and spraying with a moisture repellent.



A soiled cable can be cleaned with grease cutting household detergent. A periodic application of vinyl protector will help both ends and cable maintain their original appearance.

In case of salt water spray or immersion: Rinse plug end and/or connector end thoroughly in fresh water, shake or blow out excess water and allow to dry. Spray with a moisture repellent before reuse.

**WARNING: DISCONNECT POWER CABLE FROM POWER SOURCE BEFORE PERFORMING MAINTENANCE.**

#### Servicing The Main Distribution Panel:

*To replace a breaker or indicator light in the main distribution panel:*

- (1) Turn all breakers "OFF".
- (2) Make sure the generator is "OFF".
- (3) Unplug the shore power.
- (4) Remove the screws from the top and sides of the panel. The main distribution panel is hinged on the bottom to swing open for servicing.

Reverse the procedure for closing the panel.

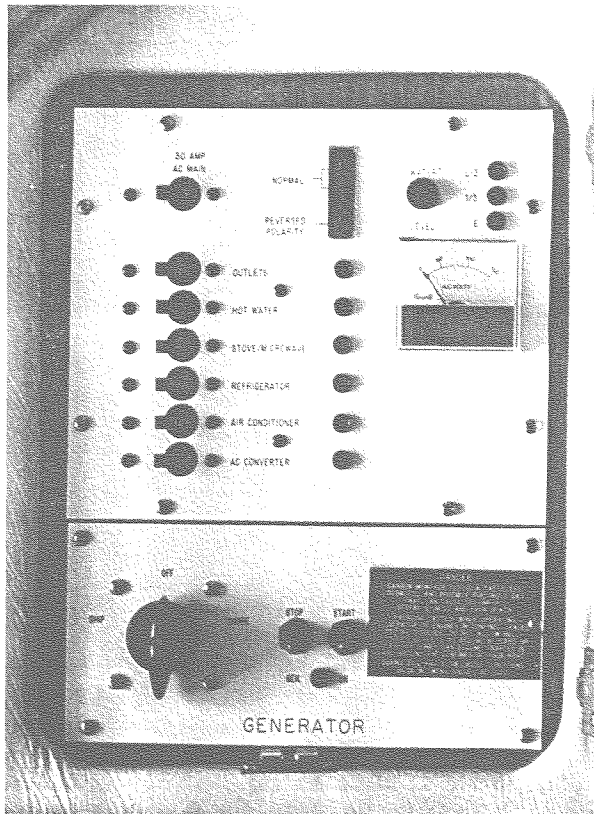

Main Distribution Panel

## BREAKERS

MAIN DISTRIBUTION PANEL	
BREAKER	AMPS
AC MAIN	30
OUTLETS	15
HOT WATER	20
STOVE/MICROWAVE	20
REFRIGERATOR	15
AIR CONDITIONER	20
AC CONVERTER	15

## CONVERTER

The A.C. to D.C. converter is fully automatic, utilizing all solid state components to maintain the 12-volt system on board. The converter is self-regulating and self-adjusting. The unit will supply power to operate 12-volt accessories as well as charge the banks of batteries. The maximum capacity of the converter is 35 amps.

The converter operates off dockside power or the generator systems. The converter will not over-charge the batteries; it is designed to cycle on and off as charge is needed. The only switch for the unit is the circuit breaker located on the main distribution panel.

NOTE: Leave the converter running at all times to maintain the 12 volt system.

**WARNING: NEVER BLOCK AIR CIRCULATION THROUGH THE UNIT. NEVER STORE ANY GEAR ON TOP OF THE UNIT.**

REFER TO OWNER'S PACKET.

## GROUND FAULT INTERRUPTER OUTLET

The ground fault interrupter outlet (GFI) in the 270 AMBERJACK, SPORTFISH and HARDTOP is located in the head storage. On the 270 SUNDANCER® it is located in the dinette area. It is equipped with a test and reset switch in the center of the face plate. All 110 volt outlets and 110 volt lighting are protected by the outlet.

The receptacle employs a ground-fault circuit interrupter to provide protection against the hazards of ground-fault currents that can cause loss of life. An example of ground-fault current is the current which would flow through a per-

son who is using an appliance with faulty insulation and at the same time, is in contact with an electrical ground such as a plumbing fixture, wet floor or earth.

If, for example, the electric razor you are using gets wet, the breaker will automatically trip to avoid electrical shock. To reset, push the switch marked "RESET". The outlet should be checked periodically by pushing the test button on the outlet itself. When this is done, there should be no power in the outlet or 110 volt lights.

**CAUTION: EVEN WITH THE PROTECTION OF THE GFI OUTLET, AN ELECTRICAL SHOCK MAY OCCUR, BUT SUCH SHOCK WILL BE OF LESS THAN NORMALLY DANGEROUS DURATION.**

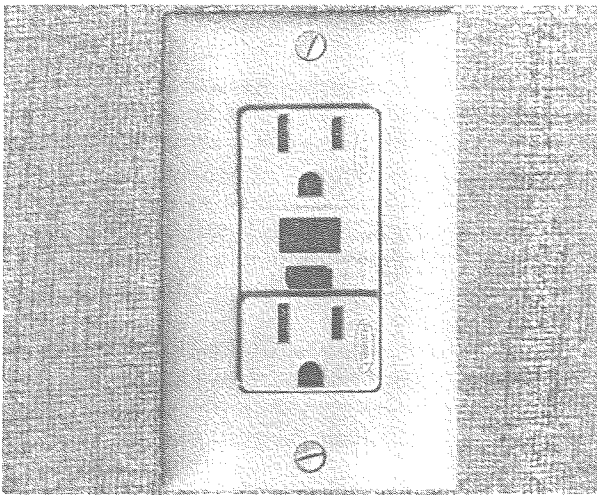

GFI Outlet

## Generators

### GENERATOR AMPERAGE OUTPUTS

<b>GASOLINE</b>		
ONAN 3.0 KW (110V)		25.0 amps
<b>DIESEL</b>		
ONAN 3.0 KW (110 V)		25.0 amps

### AMP DRAW OF ACCESSORIES

REFRIGERATOR/FREEZER (110 V)	8.0 amps
RANGE (110 V)	20.0 amps
MICROWAVE (110 V)	11.0 amps
CONVERTER (110 V)	3.0 amps
WATER HEATER (110 V)	13.6 amps
AIR CONDITIONER (110 V)	
AJ, SF & HT	15.5 amps
SUNDANCER®	14.3 amps
AIR CONDITIONER PUMP	2.0 amps

## STARTING THE GENERATOR

**NOTE: PRE-START THE GENERATOR PRIOR TO GETTING UNDERWAY AS THERE IS A POSSIBILITY IT WILL NOT PICK UP WATER IF STARTED UNDERWAY. MAKE SURE THE MAIN GENERATOR BREAKER IS OFF AND THERE IS NO LOAD ON THE GENERATOR BEFORE STARTING IT.**

*To start the Generator: (Switches located at the main distribution panel or on the generator set.)*

- (1) Open the generator seacock.
- (2) Run the bilge blowers for at least four minutes before starting and any time the generator is running.
- (3) With diesel engines, preheat the unit prior to starting. Preheat time should not exceed 30 seconds. Longer periods of preheat can ruin the manifold heater and glow plugs, although during cold weather, an additional few seconds of preheating during cranking will help prevent misfires as the unit starts running.
- (4) Hold the momentary starter switch to activate the starter motor on the generator.
- (5) As soon as the generator set starts, release the switch.
- (6) Load the generator by turning the individual equipment breakers on.

### Stopping:

- (1) After the load is removed from the generator set, let it run a few minutes to cool.
- (2) Stop the generator set by holding the momentary stop switch.

**CAUTION: DO NOT RUN THE GENERATOR OR ENGINES IN AN ENCLOSED AREA, SUCH AS A CLOSED BOAT HOUSE, AS THERE IS THE POSSIBILITY OF INHALING EXHAUST FUMES AND THE BUILDUP OF CARBON MONOXIDE.**

*To shift from shore power to generator power:*

- (1) Turn all A.C. systems off.
- (2) Start the generator.
- (3) Turn the rotary transfer switch to the "generator" position.
- (4) Turn the A.C. breakers on.

REFER TO OWNER'S PACKET.

## GENERATOR OIL/COOLANT CHART

GENERATOR	OIL (QTS.)	COOLANT (QTS.)	COOLANT (QTS.) 50/50	COOLANT (QTS.) 30/70
ONAN 3.0 KW (Gas)	3.5	3.5	1.75	1.05
ONAN 3.0 KW (Diesel)	4.0	3.0	1.50	0.90
WESTERBEKE 3.0 KW (Diesel)	2.6	6.0	3.00	1.80

## LIGHTS

AREA	TYPE	LOCATION	VOLTS	BREAKER	BULB
V-BERTH	HIGH/LOW* DOUBLE DOME SWIVEL	AFT STARBOARD SHELF	110/12	OUTLETS	GE1004LK
		OVERHEAD	12	CABIN LIGHTS	#1141
		FORWARD BULKHEAD	12	CABIN LIGHTS	#93
GALLEY	HIGH/LOW	OVERHEAD	110/12	OUTLETS	GE1004LK
HEAD	DOUBLE DOME	OVERHEAD	12	CABIN LIGHTS	#93
MID-BERTH**	DOUBLE DOME* HIGH/LOW	FWD. STBD. BULKHEAD	110/12	CABIN LIGHTS	#1141
		ABOVE ENTRANCE	110/12	OUTLETS/CABIN LIGHTS	GE1004LK
	SINGLE DOME	DOORWAY	12	CABIN LIGHTS	#1141
SALON	SWIVEL	PORT FWD. & AFT BULKHEAD	12	CABIN LIGHTS	#93
COCKPIT	SINGLE DOME	UNDER PORT & STARBOARD SIDE PANELS	12	COCKPIT LIGHTS	#1141
BRIDGE***	CONVENIENCE	PORT & STBD. SIDE PANELS	12	BRIDGE LIGHTS	#90
BILGE	SINGLE DOME	ONE FWD. & ONE AFT	12	BILGE LIGHTS	#1141

\* OPTIONAL

\*\* SUNDANCER® ONLY

\*\*\* SPORTFISH ONLY

## Electrolysis & Zinc Anodes

Electrolytic corrosion of metals on power boats can result in serious deterioration. The boat owner must be aware of the possibilities of galvanic action, (the deterioration of metals due to dissimilar characteristics when placed in salt water), and/or electrolysis.

Zinc anodes are installed to protect underwater hardware. Zinc, being much less "noble" than alloys used in SEA RAY® underwater fittings, will deteriorate first and protect the more noble parts. Do not install more than one zinc anode at a time as an excess of zinc will only

increase its rate of deterioration without adding protection.

Zinc anodes generally require replacement about once a year. (In salt water areas, replace every six months.) The need to replace anodes more frequently may indicate a stray current problem within the boat or at the slip or mooring. If zinc anodes do not need replacing after one year, they may not be providing proper protection. Loose anodes or low-grade zinc may be the problem.

**DO NOT PAINT BETWEEN THE ZINC AND THE METAL IT CONTACTS, AND DO NOT PAINT OVER THE ZINC.**

When an A.C. shore power system is connected to the boat, the underwater metal fittings will, in effect, be connected, through the water, to grounded metals ashore. The zincs will be consumed at a faster rate unless the marina maintains a protective system to prevent this. In this case, hanging a zinc in the water bonded to the metal outlet box on the dock will reduce zinc loss on the boat. Do not connect this zinc to the boat's ground system.

It is extremely important that all electrically operated D.C. equipment and accessories be wired so that the ground polarity of each device is the same as that of the battery. SEA RAY® boats have a negative ground system, which is the recommended practice throughout the marine industry. All metal items (fuel tanks, underwater gear, etc.) in the boat are connected to the zinc anode by the green bonding wire.

Electrolysis can also be caused by "stray currents" due to a fault in an electrical item, even though correctly grounded. A galvanic current blocker is standard on all SEA RAY boats. It is installed at the A.C. ground connection to the D.C. bonding system. This connection maintains the safety ground from dockside power while stopping the flow of D.C. corrosive currents.

# Section 4

## ACCESSORIES

### Air Conditioner

The SUNDANCER® air conditioning system consists of one 10,000 BTU unit located under the port side of the V-berth. The condensate drain line runs to the mid-berth sump.

The AMBERJACK, SPORTFISH and HARDTOP models have one 6,000 BTU unit located under the port side of the cockpit storage area. The condensate drain line runs to the forward bilge sump.

The air conditioner controls in the SUNDANCER are located on the port lower V-berth wall and in the AMBERJACK, SPORTFISH and HARDTOP in the galley, below the sink.

#### To start unit:

- (1) Make sure the seacock for the cooling pump is open.
- (2) Set the control knob on the air conditioner control switch assembly to "OFF".
- (3) Turn the main circuit breaker on the main distribution panel to "ON".
- (4) Turn the air conditioner breaker "ON".
- (5) Turn the control knob to "START". This will start the cooling fan only. The sea water pump will cycle on and off with the compressor.
- (6) Turn the control knob to "RUN" to activate the compressor to start heating or cooling. (Note: Reversed cycle operation is effected by the water temperature that is cycled through the equipment. Thus, as the water temperature is reduced, so is the capacity of the output of warm air.)
- (7) Turn the thermostat clockwise for cooling or counterclockwise for heating.
- (8) Set the fan speed to high.
- (9) To set the thermostat, allow the unit to run until the boat is at the desired temperature, then turn the thermostat

knob toward the center position on the switch until the first click; now the air conditioning unit will maintain a constant temperature.

#### (10) Fan speed:

Heat cycle - run at low speed for the first 5 to 15 minutes then switch to medium speed.

Cool cycle - Set to desired speed.

REFER TO OWNER'S PACKET.

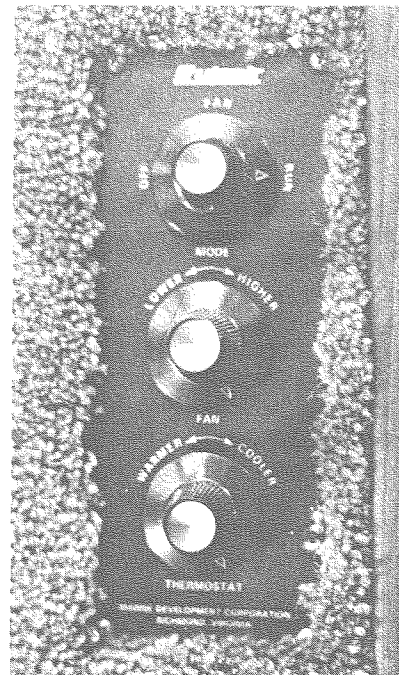

*Air Conditioner Control*

### Canvas

#### CANVAS CARE AND MAINTENANCE

**Cleaning:** Brush the canvas with a soft-bristled brush and hose down at regular intervals to remove dust and dirt particles. It may be washed in a mild solution of Lux or Ivory soap and Borateem in lukewarm water (no more than 100°F). Rinse thoroughly to remove soap. **Do not use detergents.**

For more stubborn cases, soak the canvas in a solution of ½ cup (4 oz.) Clorox, ½ cup (4 oz.) Ivory soap and one gallon warm water, for about 20 minutes. Rinse with cold water to remove all soap. **Note:** This method may remove part of the water repellence, so apply a water repellent treatment as necessary.

The canvas may be washed in an automatic washer on the “cold” cycle using 2 cups Clorox and 1 cup Ivory flakes. **DO NOT DRY IN A DRYER - ALLOW CANVAS TO LINE DRY ONLY.** The fabric is 100% acrylic and it will shrink. Canvas may be dry cleaned, but a water repellent treatment will then be necessary.

**Storage:** Do not fold or crease any of the clear vinyl panels, as cracking will result. Do not fold or store any canvas while wet. All canvas should be rolled or folded when dry and stored in a clean dry place.

REFER TO OWNER’S PACKET.

### WINDSHIELD COVER SET (SPORTFISH & HARDTOP ONLY)

The windshield cover set prevents the interior from fading and gives you added privacy. To install the canvas covers, simply unroll and snap to the windshield frame. The windshield cover set will cover the entire front windshield and side windows.

### HATCH COVERS

The canvas hatch covers are used to cut down on the amount of sunlight entering the cabin through the hatches. It is advisable to install the hatch covers whenever the air conditioner is being used. The hatch covers snap in place over the deck hatches.

### CONVERTIBLE TOP & BOOT

The convertible top installs over the cockpit seating area in the SUNDANCER® and AMBERJACK and bridge on the SPORTFISH and rolls up on the aft support when not in use. The two middle bow straps adjust to put tension on the middle bows. When installing or storing the convertible top, the pins must be removed from the support tubes. The boot zips over the convertible top after it is rolled up on the aft support.

### SIDE CURTAINS (SUNDANCER & AMBERJACK ONLY)

The transparent vinyl side curtains snap to the side of the windshield frame and zip to the underside of the top. There is a port and starboard side curtain, which roll up for storage when not in use. **Do not fold the side curtain since permanent damage can occur to the vinyl material.**

### BIMINI ENCLOSURE (SPORTFISH ONLY)

The bimini enclosure encloses the bridge to allow operation in inclement weather. To install the bimini enclosure, first, zip the front vinyl panel to the bimini top and pull down the turn studs mounted at the base of the venturi windshield. Next, install the side curtain panels by zipping them to the bimini top and snapping the bottoms to the bridge. The back curtain for the enclosure zips to the back edge of the top and snaps to the edge of the hardtop behind the rail. The door at the ladder zips up the sides and snaps at the bottom. For easy entrance to the bridge, unzip the sides of the door and roll it up. It is held in place by the attached nylon straps and snaps.

**Storage:** Roll the vinyl panels up. Do not fold.

### BRIDGE COVER (SPORTFISH ONLY)

The bridge cover stretches over the bridge and snaps in place to keep it clean and dry when the boat is not in use. To install, start at the bottom of the venturi windshield and work back along the sides and then across the back.

### AFT CURTAIN

The aft curtain may be used while underway or as a storage cover.

#### **Installation Procedure:**

- (1) Zip aft cover to zipper track on canvas top approximately 6 inches on both sides of center.
- (2) Snap center snap at transom teak deck plate.
- (3) Snap all snaps along either side up to side curtain.
- (4) Zip up side curtain and aft cover.

- (5) Snap all snaps along other side up to side curtain.
- (6) Zip up side curtain and aft cover.
- (7) Zip up aft cover completely.

**Caution:** Roll the aft cover up for storage to avoid damage to the vinyl windows.

---

## Central Vacuum System

---

The central vacuum system is a 110 volt unit located on the forward lower V-berth bulkhead. It is wired to the 20 amp stove/microwave breaker on the main distribution panel, which must be "ON" to operate the system. The 24 foot hose connects to the inlet on the central vacuum system. The disposable bag is located behind the bottom panel on the central vacuum unit. The built in switch on the hose inlet fitting activates the vacuum when the hose connector is plugged in.

---

## Halon System

---

The system uses Halon Fire Extinguishant and is installed in the bilge on the forward side of the mid-bilge liner support and is accessible through the aft center salon hatch. In the event of a fire, the heat sensitive automatic head will release the Halon as a vapor, totally flooding the area in fire-killing concentrations. The system is wired to a 5 amp breaker on the main distribution panel that must be "ON" before starting diesel engines or generator.

On diesel installations the system incorporates an engine shut-down switch with override system.

The system has an indicator light to indicate to the helmsman when the unit has discharged. Under normal circumstances, when the Halon breaker is "ON", the indicator light is on. If the unit discharges, the light will go out.

**WHEN ACTUATION OCCURS, IMMEDIATELY SHUT DOWN ALL ENGINES, POWERED VENTILATION, ELECTRICAL SYSTEMS AND EXTINGUISH ALL SMOKING MATERIALS. DO NOT OPEN THE ENGINE COMPARTMENT IMMEDIATELY!! THIS FEEDS OXYGEN TO THE FIRE AND FLASHBACK COULD OCCUR.**

Allow the Halon to "soak" the compartment for at least fifteen (15) minutes and for hot metals or fuels to cool before cautiously inspecting for cause or damage. Have portable extinguishers at hand and ready. Do not breathe fumes or vapors caused by the fire.

REFER TO POCKET "H" IN THE OWNER'S PACKET.

---

## Horns

---

The dual trumpet horns and dual air horns are operated by the momentary toggle switch on the dash. There is no maintenance required on the trumpet horn itself, although it is advisable to avoid spraying water directly into the horns. Lubricate the compressor on the air horns once a month by inserting a few drops of oil in the oil feeder, located in the compressor cover.

REFER TO POCKET "H" IN THE OWNER'S PACKET.

---

## Power Ventilation System

---

The power ventilation system removes stagnant air and odors from the head and galley areas by means of exhaust fans mounted in to the bulkheads. On the 270 SPORTFISH and HARDTOP they are controlled by a 10 amp breaker on the main distribution panel and the switch beside the vent. On the 270 SUNDANCER® and AMBERJACK they are fused underneath the dash.

---

## Refrigerator/Freezer

---

The refrigerator/freezer operates off the 110 volt (A.C.) system or the 12 volt (D.C.) system and is protected by the refrigerator breakers on the main distribution panel. It automatically switches from A.C. to D.C. when the A.C. power source is disconnected. Always operate on A.C. power when available. Turning the thermostat to the "off" position will prohibit operation on A.C. or D.C. power.

A single thermostat controls the operation of the refrigerator on A.C. or D.C. The control knob is located at the upper right and to the rear of the food compartment. The higher number the knob is set on, the colder the temperature.

The refrigerator/freezer requires no maintenance other than routine defrosting and cleaning. To defrost the freezer, turn the temperature selection knob to the "off" position and leave it until the frost melts. To clean the cabinet and interior of both the freezer and refrigerator, use a mild detergent such as a dish-washing liquid. Surfaces should be rinsed and dried carefully and thoroughly. The condenser is located at the back of unit and should be cleaned every six months. Before cleaning the condenser, turn the unit off and allow the condenser time to cool. For access to the condenser, remove the refrigerator. To clean the condenser, use a stiff brush and a vacuum cleaner.

**CAUTION: DO NOT COVER REFRIGERATOR VENTS.**

REFER TO OWNER'S PACKET.

---

## Searchlight

---

The searchlight is a spotlight and floodlight combination. The light is operated from the dash by three controls — a three-position switch, a directional switch and a rheostat. The three position switch has spotlight, floodlight and off positions.

The directional switch moves up, down, right and left, the rheostat controls the speed of the movement. The searchlight is protected by the 10 amp "spotlight" breaker on the dash, which must be turned on to operate the searchlight.

---

## Stereo

---

The AM/FM cassette player features an AM/FM stereo with station select push buttons, a cassette player with repeat track, locking fast forward and rewind, separate controls for base, treble, balance and fader and an LCD quartz digital clock with hour and minute time set buttons. The stereo has two speakers in the main cabin and two in the cockpit.

---

## Stoves

---

### ALCOHOL

The alcohol stove has two burners and an integral tank, which is pressurized by using the

built-in pump. The tank holds approximately 1 quart of ethyl alcohol. **USE MARINE STOVE ALCOHOL FUEL ONLY.**

**WARNING: STOVE FLAME CONSUMES OXYGEN, VENTILATE CABIN WHILE IN USE.**

### ELECTRIC

#### (OPTIONAL EQUIPMENT)

The electric stove operates off the 30 amp shore power system or the onboard generator.

The stove has 2 burners with 2 control wheels to provide a variation of heat. There is a safety lid shut-off switch located in the right rear frame, which will turn off the burners if the lid is accidentally closed with them on. The 20 amp stove breaker located on the main distribution panel must be on for the stove to operate.

### ALCOHOL/ELECTRIC

#### (OPTIONAL EQUIPMENT)

The alcohol/electric stove operates off the 30 amp shore power system, the onboard generator or alcohol. The stove has two burners, and a Safety Interlock and Lidswitch. The Safety Interlock and Lidswitch are operated by the button on the rear right stove frame.

**WARNING: STOVE FLAME CONSUMES OXYGEN, VENTILATE CABIN WHILE IN USE.**

To use the alcohol burners, the Safety Interlock button must be in the down position. The integral tank, which is pressurized by using the built-in pump, holds about one quart of ethyl alcohol. **USE MARINE STOVE ALCOHOL ONLY.**

For electrical operation of the stove, the Safety Interlock button must be in the up position. The 20 amp stove breaker on the main distribution panel must also be on to operate the stove.

REFER TO OWNER'S PACKET.

### MICROWAVE OVEN

The microwave oven has an electronic touch control panel, a variable power control, a memory feature, a change or cancel feature, a time of day clock, and an oven interior light. It has a 20 amp breaker on the main distribution panel that must be on to use the microwave. Details on operating and cooking can be found in the instructions included.



To remove the microwave:

1. Turn off microwave breaker.
2. Open door and remove screws from upper and lower lip of microwave.
3. Slide unit out and unplug.

---

## Windlasses

---

### BENSON AUTOMATIC WINDLASS

The Benson windlass is operated directly from the dash with a control switch. The line is fed in and out so the anchor can be raised and lowered without going onto the deck. The anchor will stow itself and coil the line in the rope locker. The 12 volt circuit breaker must be on for the unit to operate. Included with the windlass are 200 feet of 5/8" line and an anchor.

**NOTE: USE THE SAFETY HOOK SUPPLIED TO INSURE THAT THE ANCHOR IS HELD IN PLACE SHOULD THE WINDLASS FAIL.**

REFER TO OWNER'S PACKET.

# Section 5

## STORAGE & SLEEPING ACCOMMODATIONS

### Storage

In addition to the drawers, cabinets and hanging lockers the AMBERJACK, SPORTFISH and HARDTOP have storage areas under the cushions of the V-berth.

The SUNDANCER® has storage areas under the aft starboard cushion of the V-berth and under the center cushion of the mid-berth.

### Sleeping Accommodations

To convert the V-berth in the 270 AMBERJACK, SPORTFISH and HARDTOP to sleeping position; place the support rods into notches located on the inboard edges of the seat base and place filler cushions on top.

The 270 SUNDANCER has a mid-berth in addition to the V-berth and dinette. To convert V-berth to sleeping position place rod across the notches provided on the starboard side and place spacer board across the rod and port support. Insert fill cushion.

The dinette is converted to sleeping position by sliding out supports from under cushions, dropping the legs underneath and filling outboard space with back cushion.

The mid-berth has two spacer boards which lay across the center supports and filler cushions to lay on top.

# Section 6

## STORAGE & LAUNCHING PROCEDURES

### Laying-Up Instructions

#### LIFTING THE BOAT

When lifting the boat always keep the bow higher than the stern to drain the exhaust lines and to prevent water from running forward through the manifold and into the engine itself where it can become trapped. It may seem expedient to lift only the stern when changing a propeller, but this can result in water entering the engine cylinders, causing hydrostatic lock and resulting in bent rods and quite possibly engine failure. Even a small amount of water in the engine can cause rust and is to be avoided.

With fiberglass boats, severe gelcoat crazing or more serious hull damage can occur during launching and hauling if pressure is created on the gunwales by the slings. Flat, wide belting-type slings and spreaders long enough to keep pressure from the gunwales are necessary. Cable-type slings should be avoided. Do not place the slings where they may lift on the pro-

PELLER shaft or other underwater fittings. The slings should be in accordance with the designated areas imprinted on the deck to assure the least amount of stress on the hull.

**Never hoist the boat with an appreciable amount of water in the bilge.** Fuel and water tanks should preferably be empty, especially if of large capacity.

**CAUTION: DO NOT USE THE CLEATS FOR LIFTING.**

#### SUPPORTING THE BOAT DURING STORAGE

A cradle is the ideal support for the boat whenever it is not in the water. Properly designed and constructed, it will provide support at the proper points, which is essential to avoid stress on the hull.

#### DRAINING THE BOAT

In climates where freezing occurs, it is important that the bilge be completely drained and

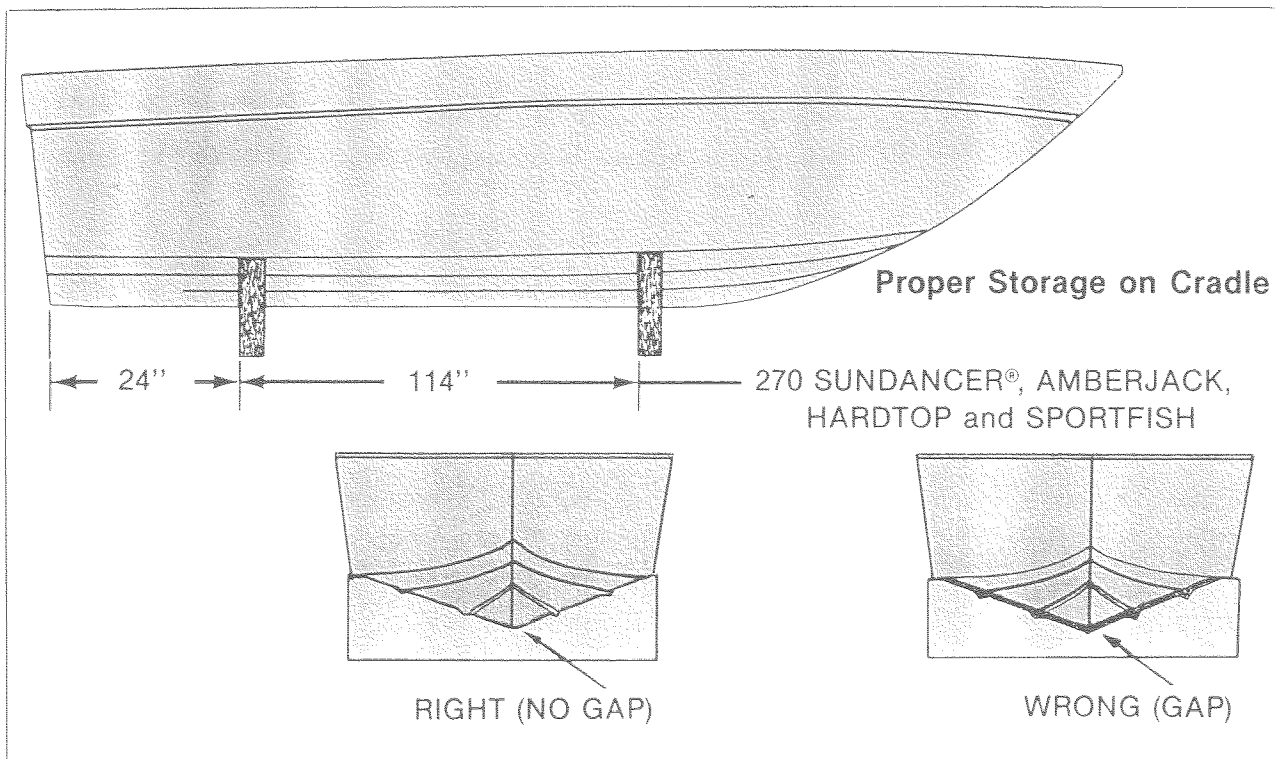

dried out when the boat is laid up for the winter. All boats are equipped with a drain plug for this purpose. Some compartments in the bilge may not drain completely because of the position of the boat. They should be completely pumped out and sponged until completely free of water.

The engine cooling system and the exhaust system must be free of water if there is danger of freezing. Drain plugs are provided on the engine for this purpose. It is necessary to open a connection or two in the exhaust system to drain the lowest portions; these should be reassembled securely immediately after draining is accomplished.

## WINTERIZATION CHECKLIST FOR BOATS STORED ON LAND

- (1) **Boat Storage**
    - Store boat in a bow high attitude.
    - Remove hull drain plug.
    - Pour one (1) pint of anti-freeze in each bilge pump sump.
  - (2) **Water System**
    - Turn on fresh water pump.
    - Open all faucets, let system drain completely, leave faucets open.
    - Turn off fresh water pump.
    - Remove hoses from each side of the water pump.
    - Remove hoses from water heater and open drain plug.
    - Blow out all lines to clean.
  - (3) **Engines**
    - Flush engines with fresh water.
    - Remove engine drain plugs, open pet-cocks and seacocks.
    - Remove drain plugs from mufflers and strainers.
    - If the boat is equipped with a heat exchanger to heat water from the engine, break the connection to the heat exchanger to drain it and the lines.
    - Refer to your engine operator's manual for detailed information on preparing the engine for storage and winterization.
  - (4) **Generator**
    - Flush generator with fresh water.
    - Remove drain plugs from generator, strainer and muffler.
    - Refer to your generator operator's manual for detailed information on preparing the generator for storage and winterization.
  - (5) **Air Conditioner**
    - Close thru-hull seacock, remove hoses from sea water pump.
  - Flush system with fresh water through hose from sea water pump.
  - Loosen the screws on the pump head, allowing water to drain from the pump.
  - Blow out water lines with air pressure.
  - Remove hoses from condensing unit.
  - Remove strainer plug.
- (6) **Batteries**
    - Remove from boat and store away from freezing temperatures.
    - Store on a wooden pallet and keep under a trickle charge.
  - (7) **Head System — Manual Flush System With Holding Tank**
    - Flush entire system thoroughly with fresh water.
    - Pump out holding tank.
    - Shut off water breaker on dash panel and remove hoses from each side of the water pump.
    - Remove water line from inlet fitting located on back side of manual pump.
    - Pump one gallon of antifreeze mixed with one gallon of water through toilet.
    - Drain toilet by removing the drain plug in the base and operating the pump handle.
    - Pump out holding tank.
  - (8) **Head System — Vacu-Flush System With Holding Tank or San X System**
    - Flush entire system thoroughly with fresh water.
    - On San X system, replace chemical bottle with ½ quart of antifreeze mixed with ½ quart water.
    - Pump out holding tank or set control switch to "Treat and Discharge" on San X model.
    - Shut off water breaker on dash panel and remove hoses from each side of water pump.
    - Remove water line from inlet fitting located on back bottom half of water valve on head.
    - Flush one gallon antifreeze mixed with one gallon of water through toilet and let vacuum pump run for one or two minutes.
    - Pump out holding tank or set control switch to "Treat and Discharge" on San X model and run through one complete cycle.
    - On San X model remove antifreeze solution from chemical reservoir and replace empty reservoir on treatment device.

**CAUTION:** Use an automotive or commercial ethylene glycol base antifreeze. Do not use alcohol base products.

## (9) Fuel Systems

### Gasoline:

- Fill fuel tanks with gasoline and a gasoline stabilizer and conditioner, such as "Sta-bil," to treat the gasoline.
- Run engines for ten minutes to ensure that all gas in carburetor and fuel lines is treated.

### Diesel:

- Diesel fuel must be treated with a biocide, "Biobor," which prevents bacteria and fungi from contaminating diesel fuel that contains some water.
- Diesel fuel should also get a petroleum distillate additive, such as "Sta-bil" or "Recor RX 100," this will help assimilate water in the fuel and prevent freezing problems.
- Fill fuel tanks with the treated fuel.
- Run engines for ten minutes to ensure that all diesel fuel in injectors and fuel lines is treated.

**CAUTION:** Do not overfill. Filling a tank until fuel flows from vents is dangerous. Allow room for expansion.

REFER TO INDIVIDUAL OWNER'S MANUALS FOR SPECIFIC PROCEDURES.

## Fitting Out After Storage

### FUEL SYSTEM

Check the entire fuel system for loose connections, worn hoses, leaks, etc. and repair. This is a primary safety precaution.

### BATTERIES

Before installing the batteries, clean the terminal posts with a wire brush or steel wool and then attach the cables. After the cable clamps are tightened, smear the post and clamps with vaseline or grease to exclude air and acid. Do not apply grease before attaching and tightening the terminal clamps. Examine all wiring.

### SHAFT ALIGNMENT

After winter storage and launching, some engine-to-shaft misalignment can be expected. Refer to page 12 for instructions on checking the alignment.

## MISCELLANEOUS

- (1) Check all thru-hull fittings for unobstructed water passage. Be alert for any deteriorated hoses and/or fittings below the water line which might fail in service and admit water.
- (2) Test the navigation lights.
- (3) Check all wiring for loose connections.
- (4) Check all switches and equipment for proper operation. Anchor lines and gear should be inspected and replaced if necessary.
- (5) Make sure the hull drain plug is in place.
- (6) Clean the bilge thoroughly if it was not done at lay-up.
- (7) Make sure exhaust system drain plug is in place and check all exhaust connections to avoid exhaust and carbon monoxide (CO) leakage.

# Section 7

## CARE & REFINISHING

---

### Fiberglass

---

The fiberglass hull, deck and some interior parts consist of the molded shell and exterior gelcoat. The gelcoat is the outer surface, often colored, that presents the shiny smooth appearance which is associated with fiberglass products. In some areas, this gelcoat surface is painted or taped for styling purposes.

Wash the fiberglass regularly with clean, fresh water. Wax gelcoated surfaces to maintain the luster. In northern climates, a pre-launch waxing may suffice for the season. In southern climates, a semi-annual application of wax will be required for adequate protection.

If the gelcoated surface gloss cannot be restored by waxing, hand buff with a rubbing compound such as DuPont No. 7, or power buff with Mirror-Glaze No. 1, then wax.

### STAINS AND SCRATCHES

Gelcoat surfaces are very resistant to deep stains. Common surface stains can be removed with diluted household detergents, providing these detergents do not contain ammonia or chlorine. Porcelain-cleaning powders are too abrasive and often contain chlorine and ammonia, either of which would permanently discolor the gelcoat. Alcohol or kerosene can be used for difficult stains but should be washed away promptly with a mild detergent and water. Never use acetone or any ketone solvents.

Minor scratches and deeper stains which do not penetrate the gelcoat may be removed by light sanding and buffing.

---

### Bottom Paint

---

From time to time a slight algae or slime forms on all vessels. The bottom painted portion of the hull can be wiped off with a coarse turkish towel or a piece of old rug while the boat is in

the water. **Do not use a stiff brush or abrasive material to clean the bottom.**

The bottom paint should be inspected annually. If it needs repainting, flush the old paint and wash with hot water and Tide detergent. Rinse well and let surface dry completely. Feather any deep scratches with sandpaper and repaint, following the directions on the Sea Hawk bottom paint label. Replacement coating can be ordered from your SEA RAY® dealer.

Fiberglass hulls should never be hauled, painted and relaunched the same day since this does not allow sufficient time for the moisture which has been absorbed into the old paint film to completely dry out. Generally, 24 to 36 hours of drying time is required.

---

### Deck Hardware

---

The deck hardware on your boat consists of stainless steel and marinium castings. Frequent cleaning with polish will extend their life and enhance their appearance. ("Boaters' Choice Rust and Stain Remover" is recommended.) A daily rinsing with fresh water to remove the salt spray deposits will prolong the quality finish.

---

### Plexiglass

---

**Never use a dry cloth or duster, or glass cleaning solutions on plexiglass.**

To clean plexiglass, first flood it with water to wash off as much dirt as possible. Next, use your bare hand, with plenty of water, to feel and dislodge any caked dirt or mud. A soft, grit-free cloth may then be used with a non-abrasive soap or detergent. A soft sponge, kept clean for this purpose, is excellent. Blot dry with a clean damp chamois.

Grease and oil may be removed from plexiglass with kerosene, hexane, white (not aviation or ethyl) gasoline or aliphatic naphtha (no aromatic content).

Do not use solvents such as acetone, silicone spray, benzine, carbon tetrachloride, fire extinguisher fluid, dry cleaning fluid or lacquer thinner on plexiglass, since they attack the surface.

Most minor scratches can be removed or reduced by hand polishing or buffing.

---

## Teak

---

Teak does not require refinishing but should be cleaned occasionally with a teak cleaner, obtainable at marine supply stores. Do not use steel wool in cleaning teak — it leaves rust specks. Bronze wool is available and should be used. Several penetrating protective coatings are available for treating teak and their use is considered advantageous. Because some cleaners can damage gelcoats and aluminum, always consult the directions before using any cleaner.

---

## Window Channels

---

To avoid unnecessary deterioration of the nylon pile incorporated in some sliding window channels, solutions containing sodium or calcium hypochlorite, found in many household cleaners and bleaching solutions, should not be used for washing sliding windows. Most mild detergents, liquid or powder, are satisfactory, but if the cleaning agent gives off an odor of chlorine, it should be avoided.

---

## Interior Fabrics

---

### VINYL (INTERIOR & EXTERIOR)

In general, most household soil can be easily cleaned with warm soapy water and several clear water rinses. Moderate scrubbing with a medium bristle brush will help to loosen the soiling agent from the depression of embossed surfaces. Full strength rubbing alcohol or bleach diluted with water may be tried if the above suggestions do not work.

**Note: We do not recommend use of any cleaners or sealers on interior or exterior vinyls.**

### COTTON/POLYESTER BLEND FABRICS

The blended fabrics should only be cleaned with dry cleaning fluid. It is the **only** approved solvent. Bed spreads and curtains should be dry cleaned only.

# Section 8

## SERVICE INFORMATION

### Useful Service Information

OWNER \_\_\_\_\_

HOME PORT \_\_\_\_\_

BOAT NAME \_\_\_\_\_

REGISTRATION NUMBER \_\_\_\_\_ STATE \_\_\_\_\_

HULL SERIAL NUMBER \_\_\_\_\_

WARRANTY REGISTRATION DATE \_\_\_\_\_

ENGINE MAKE & MODEL \_\_\_\_\_

SERIAL NUMBER PORT \_\_\_\_\_ STARBOARD \_\_\_\_\_

GEAR MAKE & REDUCTION RATIO \_\_\_\_\_

SERIAL NUMBER PORT \_\_\_\_\_ STARBOARD \_\_\_\_\_

PROPELLER SIZE \_\_\_\_\_ SIZE \_\_\_\_\_

PART NUMBER PORT \_\_\_\_\_ STARBOARD \_\_\_\_\_

SHAFT SIZE (DIAMETER X LENGTH) \_\_\_\_\_ MATERIAL \_\_\_\_\_

FUEL CAPACITY \_\_\_\_\_

WATER CAPACITY \_\_\_\_\_

KEY NUMBER, IGNITION \_\_\_\_\_ DOOR \_\_\_\_\_

SELLING DEALER \_\_\_\_\_

CITY & STATE \_\_\_\_\_

LENGTH \_\_\_\_\_

BEAM \_\_\_\_\_

DRAFT \_\_\_\_\_

VERTICAL CLEARANCE \_\_\_\_\_

ESTIMATED WEIGHT \_\_\_\_\_

BATTERY VOLTAGE \_\_\_\_\_ GENERATOR KW \_\_\_\_\_





REFER TO THIS MANUAL FOR DETAILS.

	BEFORE EVERY USE	AFTER FIRST 20 HRS.	EVERY 50 HOURS	EVERY 100 HOURS	ANNUALLY
CHECK SEAWATER STRAINERS & SEACOCKS	X	X	X		
LUBRICATE SEACOCKS					X
CHECK ENGINE ALARMS	X				
CHECK EXHAUST SYSTEM FOR LEAKS	X	X		X	
CHECK FUEL SYSTEM LINES & CONNECTIONS	X	X	X		
CHECK GENERATOR OIL LEVEL	X				
LUBRICATE THROTTLE & SHIFT LINKAGE PIVOT POINTS		X		X	X
CHECK ALL ELECTRICAL CONNECTIONS		X			X
INSPECT PROPELLER FOR POSSIBLE DAMAGE			X		
CHECK ENGINE TO OUTDRIVE ALIGNMENT		X			X
INSPECT FRESH WATER PUMP & WATER SYSTEM		X		X	
CHECK SAN X TREATMENT CHEMICAL	X				
CHECK FLUID IN TRIM TAB PUMP		X			X
TEST GFI OUTLET					X
CHECK OIL IN STEERING SYSTEM (SPORTFISH ONLY)	EVERY 3 MONTHS				
ADD "RACOR" FUEL ADDITIVE TO FUEL TANKS (Diesel)	EVERY MONTH				