

## Sure Cure<sup>®</sup> Kit

**Part No.**  
**SC-41TE**

### Valve Body Parts

#### Converter Regulator Valve Kit

**92835-03K** Patent No. 6,793,053

#### Pressure Regulator Sleeve

**92835-07**

#### Solenoid Switch Valve Plug Kit

**92835-02K** Patent No. 7,001,300

#### Solenoid Pack Repair Kit

**92836-03K**

### Reassembly Parts

#### Pump Bushing

**12502-01**

#### OD Clutch Hub Bushings

**92004-L** Late Style

**92004-LOS** Late Style

#### Input Clutch Hub Bushing

**92003-01K**

**NOTE:** Sonnax highly recommends tool **92003-TL** for removal and installation of this bushing.

#### Accumulator Sleeve & Piston Kit

**92834-03K**

#### Differential Bearing Shims

**39539-Z5** (2) For 2.48" bearing

**39540-Z5** (2) For 2.88" bearing

#### Output & Transfer Shaft Shims

**92965-Z5** (2)

#### Low/Reverse Piston Retainer Lube Feed Seal Kit

**92106-01K** Patent No. 6,835,150

## Chrysler 40TE, 40TES, 41AE, 41TE, 41TES, 42LE

**THE SURE CURE**



**An installation tool is highly recommended for removal and installation of the input clutch hub bushing:**

**Part No.**  
**92003-TL**

Patent No. 6,591,469

**NOTE:** Recommended for use with input clutch hub bushing **92003-01K**. Instructions are provided with this tool.



TORQUE SPECIFICATIONS
Pump to stator 20 ft. lbs.
Pump to case 20 ft. lbs.
Valve body to case 105 in. lbs.
Valve body bolts 45 in. lbs.
Solenoid assembly to case 105 in. lbs.
Transfer gear nut 200 ft. lbs
Output gear bolt 200 ft. lbs
Oil pan & differential cover 165 in. lbs.
Low/reverse piston retainer 45 in. lbs.
End cover bolts 14 ft. lbs

CLEARANCE AND ENDPLAY
Total Unit Endplay .005" to .025"
Pump Clearance Outer gear to pocket (.002" to .006")
Pocket depth, gear endplay (.0008" to .002") Tapered Bearing Settings (new bearings)
Differential bearings 5 to 18 in. lbs drag/rotational torque
Output gear 3 to 8 in. lbs drag/rotational torque
Transfer shaft .002" to .004" end play

CLUTCH CLEARANCE
Low/reverse .035" to .042" ( selective pressure plate) reducing clearance to .035" can substantially improve 2-1 shift quality.
2-4 clutch .030" to .042" ( selective pressure plate)
Reverse clutch .030" to .049" (selective snap ring)
Overdrive clutch .038" to .089" (no adjustment)
Underdrive clutch .036" to .058" ( selective pressure plate)

TECH TIP
* Cooler return line = front line
* Converter bolts can be too long or stretched to the point they can dimple inside of the converter. This deforms the converter friction surface causing converter failure. ALWAYS use new converter bolts or add a washer.
* Use Chrysler 7176 oil to reduce TCC & shift shudder, and harsh coastdown shifts.
* Always install a new cooler bypass plug in case behind pump. Internal wear can cause valve to intermittently stick open.
* Use a drill bit to check vehicle harness connector pin tension. Round over shank end of .090" diameter bit.

## STEP 1 INSTALL CONVERTER REGULATOR VALVE KIT

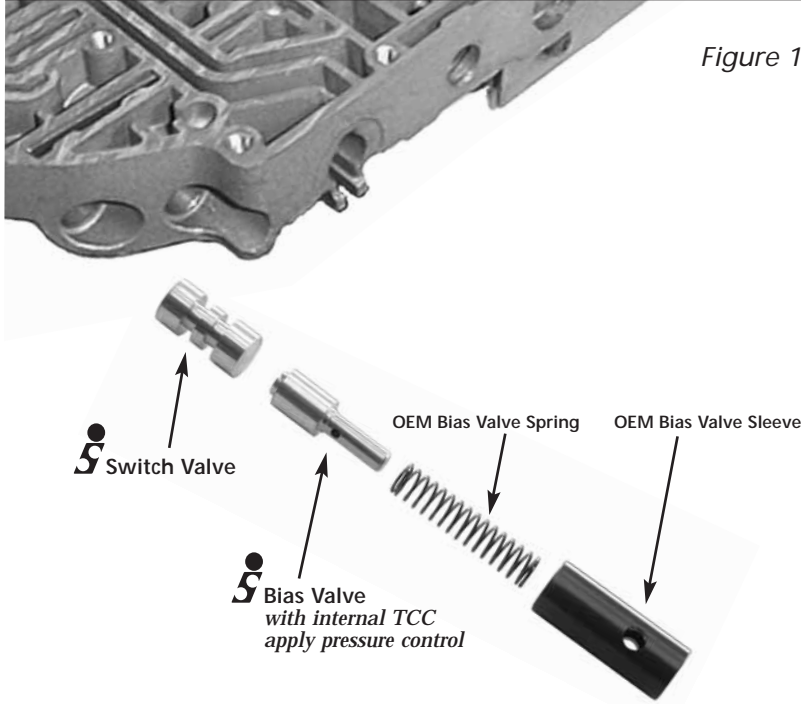

Figure 1

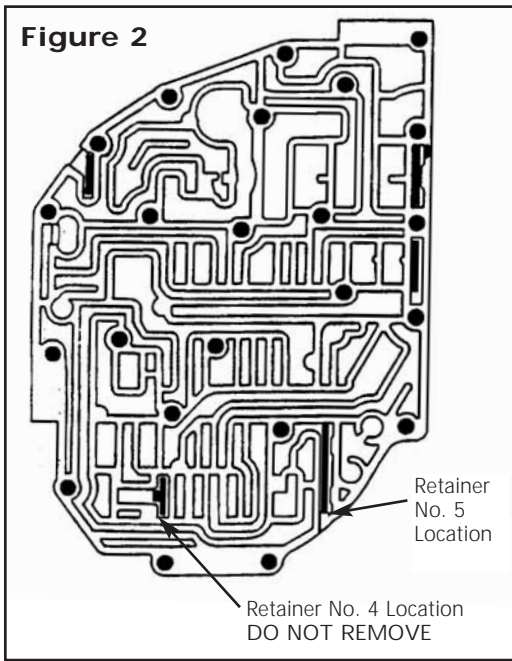

Figure 2

## SEPARATOR PLATE

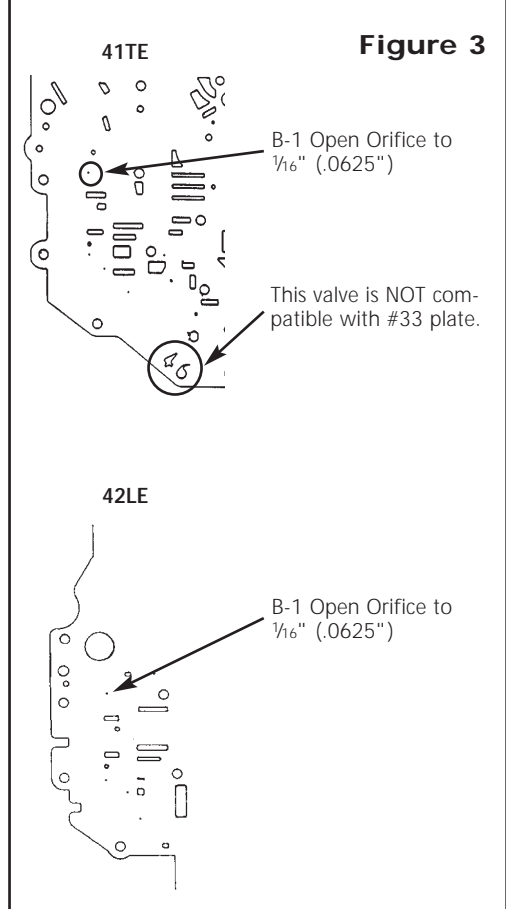

Figure 3

## SEPARATOR PLATE INFORMATION

### #33 plate and body:

The Sonnax converter regulator valve kit is not compatible with valve bodies that have a #33 separator plate. A complaint of no TCC or engine stumble from TCC drag is common with worn #33 valve bodies. These units may be repaired by installing a later version valve body and plate with the Sonnax kit.

### #66/99 plate and body:

The #66/99 version valve body and plate is a later design, sold as the replacement for earlier versions. This valve body has an improved TCC control valve, providing better lockup control. It is still recommended that the Sonnax TCC regulator valve be installed with this valve body.

## INSTRUCTIONS

1. Remove OEM retainer #5 and TCC switch valve train. Do not remove retainer #4 (see Figure 2).
2. Install the Sonnax switch valve and bias valve, reusing the OEM bias valve spring, sleeve and retainer (see Figure 1). Install the rounded spool inboard toward the inner clip and the flat spool facing outboard toward the bias valve. See illustration below.
3. Drill out the "B-1" hole in the separator plate to  $\frac{1}{16}$ " (.0625") (see Figure 3).

The Sonnax Converter Regulator Valve eliminates high apply pressure spikes, reducing the likelihood of converter failure and shudder complaints.

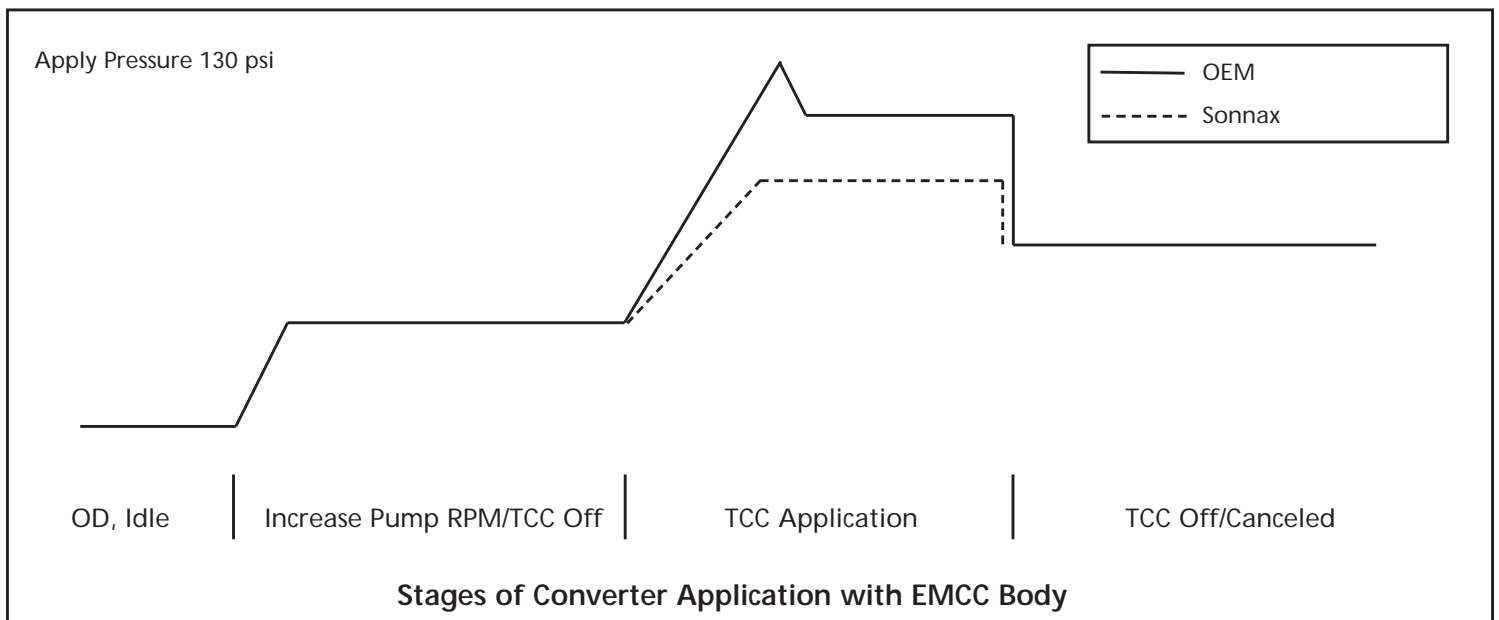

## STEP 2 INSTALL PRESSURE REGULATOR REDUCING SLEEVE

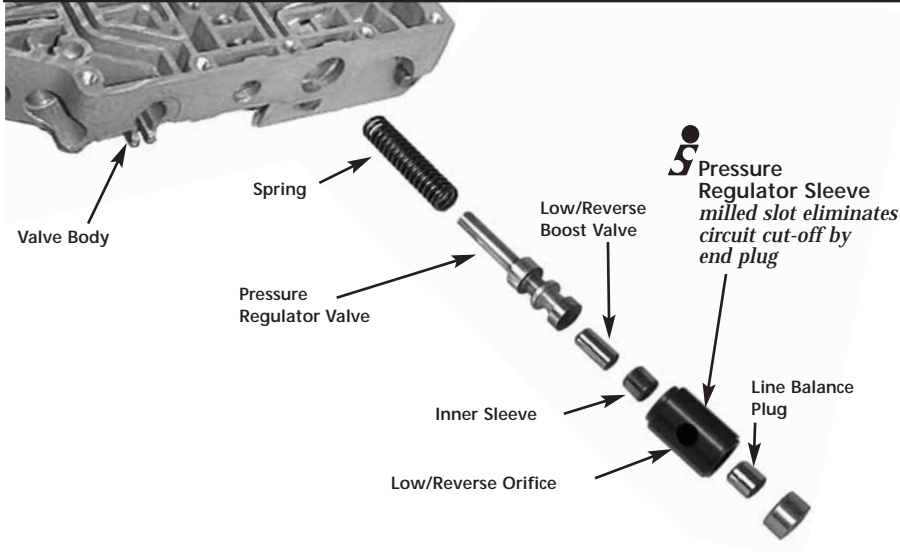

1. Remove the retainer, end plug and regulator sleeve assembly from the valve body bore.
2. Discard the worn regulator sleeve.
3. Insert the replacement sleeve, ensuring that the parts are in the correct orientation. The milled slot on the sleeve goes out toward the end plug.

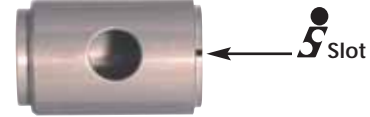

## STEP 3 INSTALL SOLENOID SWITCH VALVE PLUGS

1. Remove the original three solenoid switch valve plugs, saving the outermost plug.
  2. Buff out the valve body bore to remove any ridged aluminum.
  3. Install the Sonnax replacement plugs.
- Note: Edge relief end of Sonnax plug faces out toward OEM plug. See illustration below.*
4. Return the original plug to the valve body bore end and install the retainer.

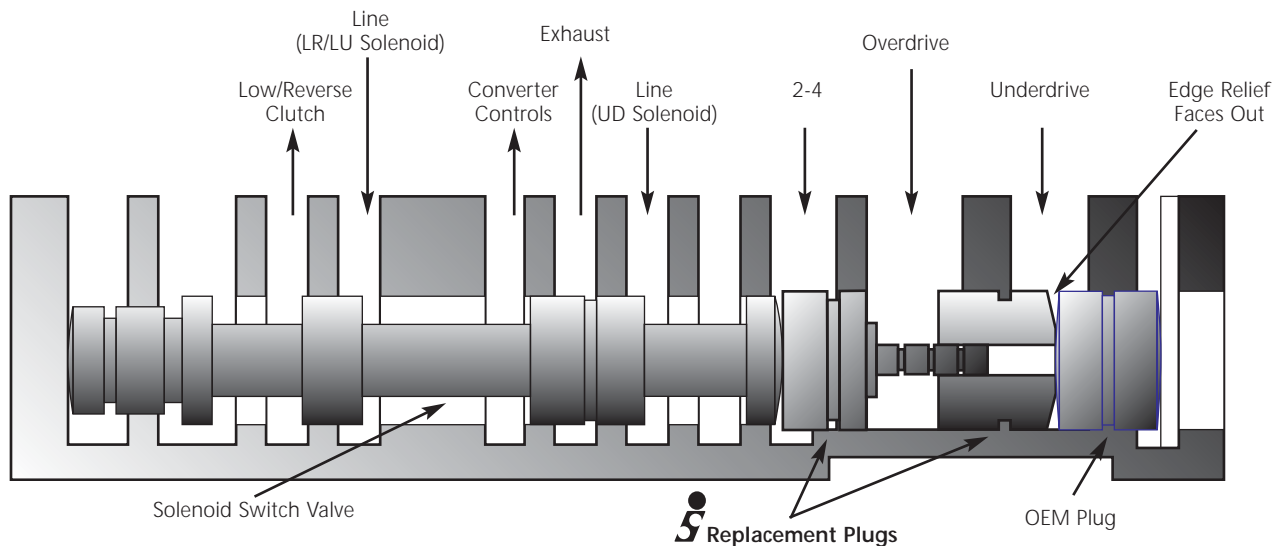

## STEP 4 INSTALL SOLENOID RUBBER DIAPHRAGM AND BRASS CONTACT

Install the new diaphragms and brass contacts in the solenoid as replacement of OEM parts. Deep cup side of diaphragm goes up, small relief on other side sits on contact.

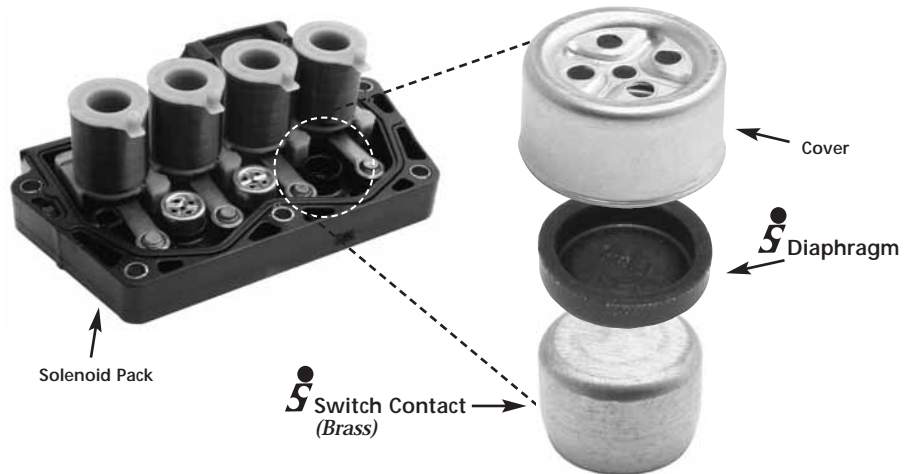

## STEP 5 INSTALL ACCUMULATOR PISTON & SLEEVE KIT

Note: Shudder on 1-2, 2-3, or 3-4 shifts are all common complaints on 41TE and 42LE units. The SC-41TE kit contains one **92834-03K** accumulator sleeve and piston kit which may be installed in either low/reverse, 2-4, or underdrive/overdrive bores to address these issues. All three bores should be inspected for scoring. The **92834-03K** reuses OEM springs and will provide shorter than factory shifts. Additional kits may be ordered separately if multiple bores require servicing. **92834-05K** kit includes replacement springs along with the piston and sleeve to produce a shift rate closer to OEM. This kit is also available separately and can be used in any of the three bores.

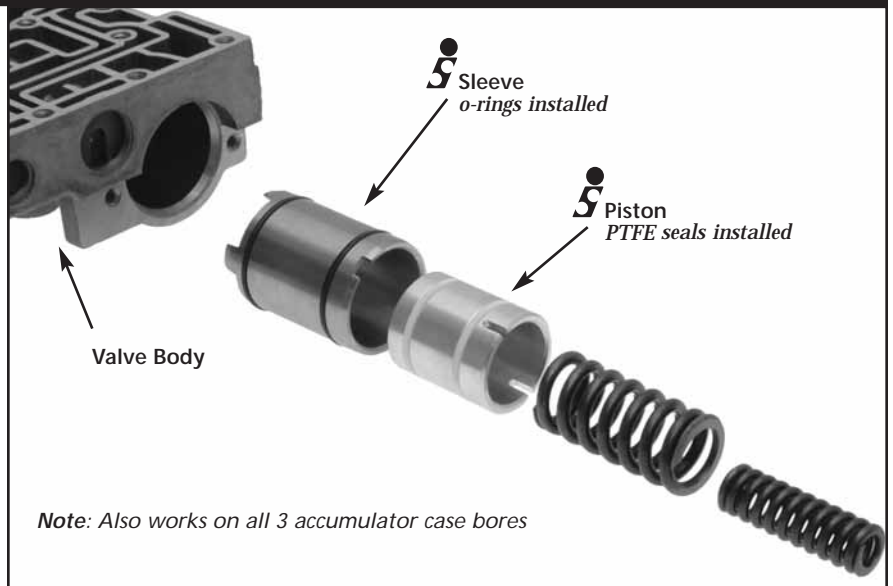

1. To install the steel accumulator bore sleeves, pre-lube the O-rings and install in the two grooves. Refer to the following list and photos below and on the following page for proper orientation.

### Sleeve Orientation

- Underdrive & overdrive bores: 4 tabs in case first
- Low/reverse bore: 4 tabs toward cover
- 2-4 bore: 4 tabs into valve body bore first

2. To install the piston, pre-lube the PTFE seals and install in the two grooves. Refer to the following list and photos below and on the following page for proper piston/spring orientation.

### Piston and Spring Orientation

- Underdrive & overdrive bores: open end of piston and large spring toward cover
- Low/reverse bore: springs and open end of piston in case first
- 2-4 bore: open end of piston and springs facing out of valve body bore

## 2-4 ACCUMULATOR

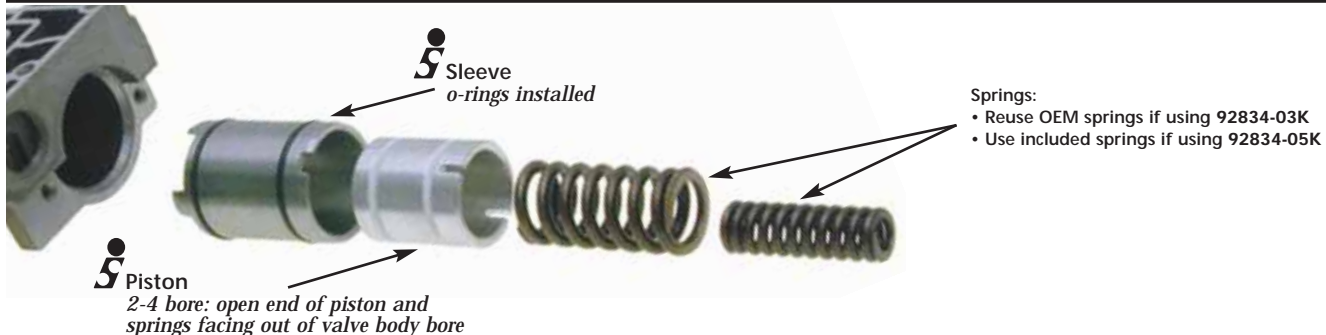

**STEP 5 (CONTINUED) UNDERDRIVE/OVERDRIVE BORE**

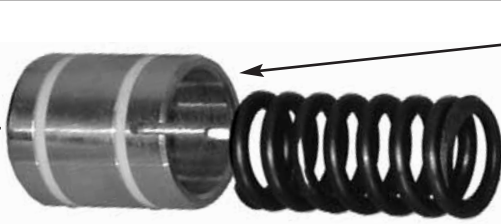
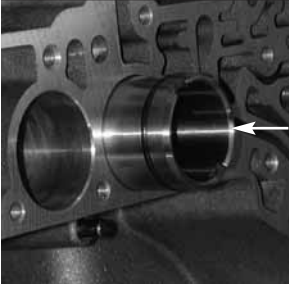

**Piston**  
Underdrive & overdrive bores:  
open end of piston and large  
spring toward cover

**Spring:**  
• Reuse OEM spring if using 92834-03K (included in this kit)

**UNDERDRIVE/OVERDRIVE BORE**

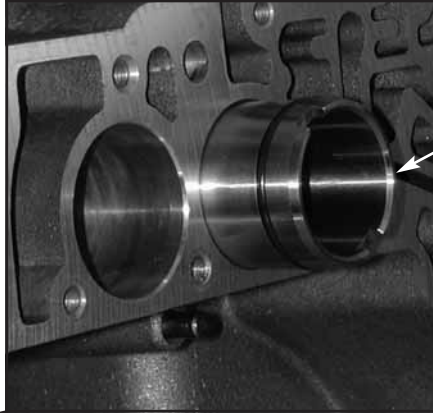

**Bore Sleeve**  
Underdrive & overdrive  
bores: 4 tabs in  
case first

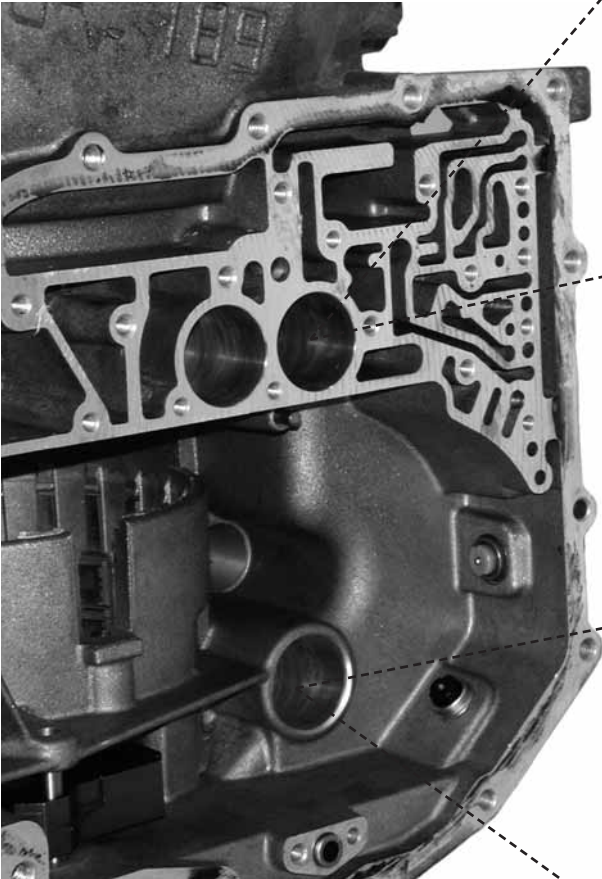

**LOW/REVERSE BORE**

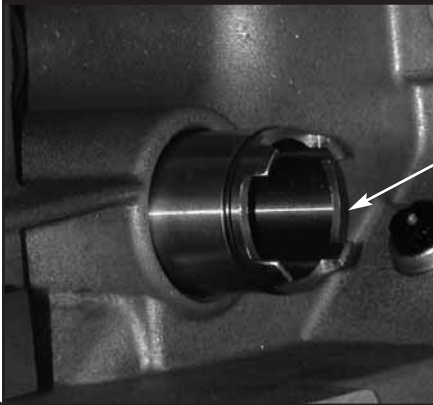

**Bore Sleeve**  
Low/Reverse bore:  
4 tabs toward cover

**LOW/REVERSE BORE**



**Spring:**  
• Reuse OEM springs for 92834-03K  
(included in this kit)

**Piston**  
Low/Reverse bore:  
springs and open end of  
piston in case first

## STEP 6 INSTALL INPUT CLUTCH HUB BUSHING

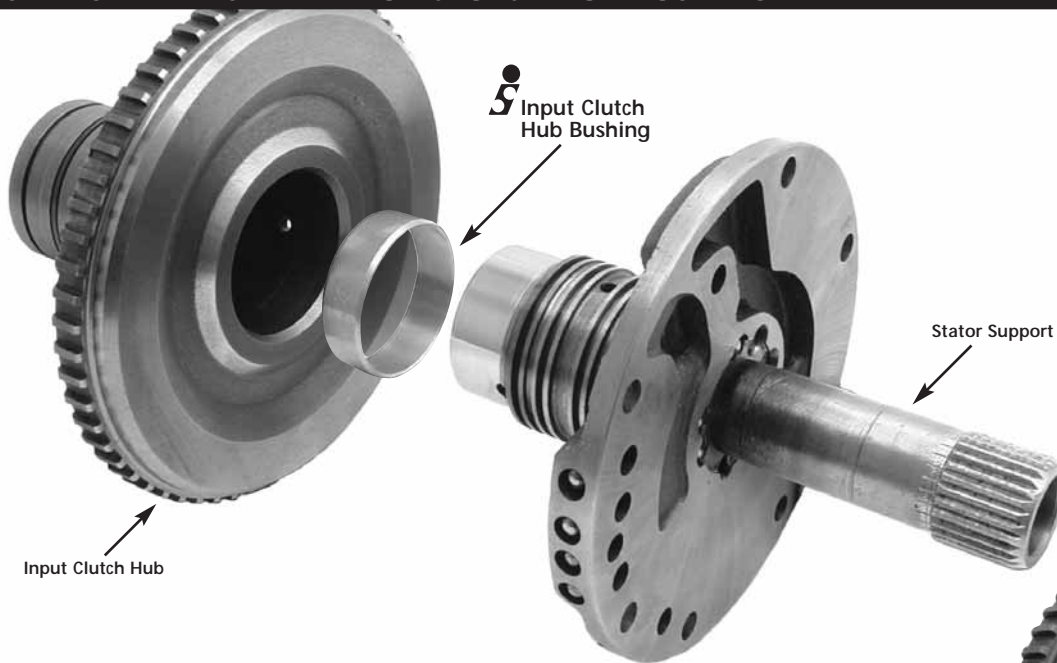

1. Insert the bushing tool 92003-TL (U.S. Patent 6,591,469) into the worn bushing in the housing as shown.

2. Screw the two bolts all the way into the bushing tool.
3. The bolts will thread grooves into the soft bushing I.D.
4. Screw the other bolt into the center of the bushing tool from the opposite end.
5. Drive the bushing and tool out using a hammer or arbor press.

6. Remove the three bolts and worn bushing from the bushing tool.
7. Inspect the input drum bore for any damage.
8. Screw one bolt into the top center of the bushing tool.
9. Insert the new bushing and bushing tool as shown at right.
10. Use an arbor press to push the bushing in place. Do not hammer in.

*Note: In most cases the pump support shaft will spin freely in the input hub. However, if it does not, it may be necessary to polish the pump support shaft for added clearance.*

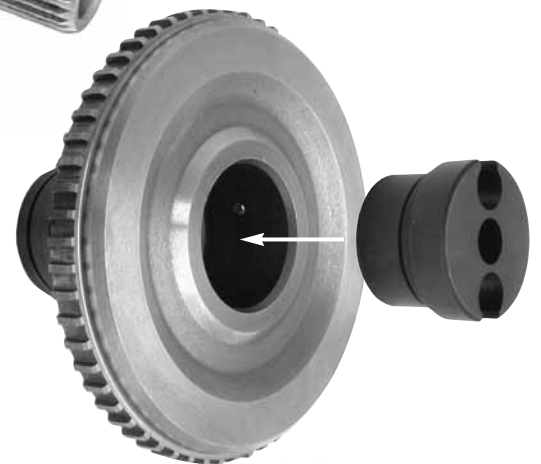

## STEP 7 INSTALL OVERDRIVE CLUTCH HUB BUSHINGS

1. Verify correct part number application.
2. If the OD of the overdrive clutch hub measures 1.162", compare the oil feed holes to the photo. Third design hubs require a different bushing than late design hubs; both bushings are included in kit.
3. Remove the two OE steel-backed bushings from the inside diameter of the overdrive clutch hub shaft.
4. Press the replacement bushing into the overdrive shaft, making sure that the cross hole lines up with the cross hole in the over drive shaft.

### Note:

Bushing 92004-SP is for the early design (1995 & earlier) A604.

Bushing 92004-L is for later design (1996 & up) A604 and 42LE units.

Bushing 92004-LOS is for late design oversized (1996 & up) A604 and 42LE units

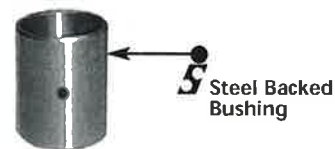

Early Design: OD Ø 1.142"  
Requires bushing 92004-SP

Late Design: OD Ø 1.162"  
Requires bushing 92004-L

3rd Design: OD Ø 1.162"  
Requires bushing 92004-LOS

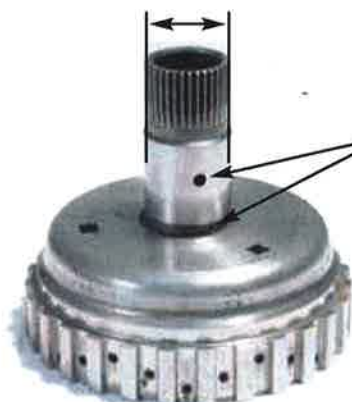

## STEP 8 INSTALL LOW/REVERSE PISTON RETAINER AND SEAL

1. Remove any residual gasket material on the case and piston retainer.

**Important:** Inspect the piston retainer for distortion around the screw holes. This distortion must be corrected prior to reinstallation or the retainer should be replaced with a new one.

2. Insert the Sonnax grommet seal into the low/ reverse feed hole in the bottom of the transmission case with the small end of the seal fitting into the hole.
3. Position the Sonnax steel shim into place, aligning the holes and taking care that the steel does not overlap or pinch the flange of the rubber seal.
4. Install the piston retainer on top of the steel shim and seal assembly, aligning the holes and installing the original screws to the OEM torque specifications (45 inch lbs.).

**Notes:** Retaining compound should be used on the screw threads.

New design shim can be used to replace early, unslotted or new, slotted gaskets. Do not use an early shim to replace a late, slotted gasket.

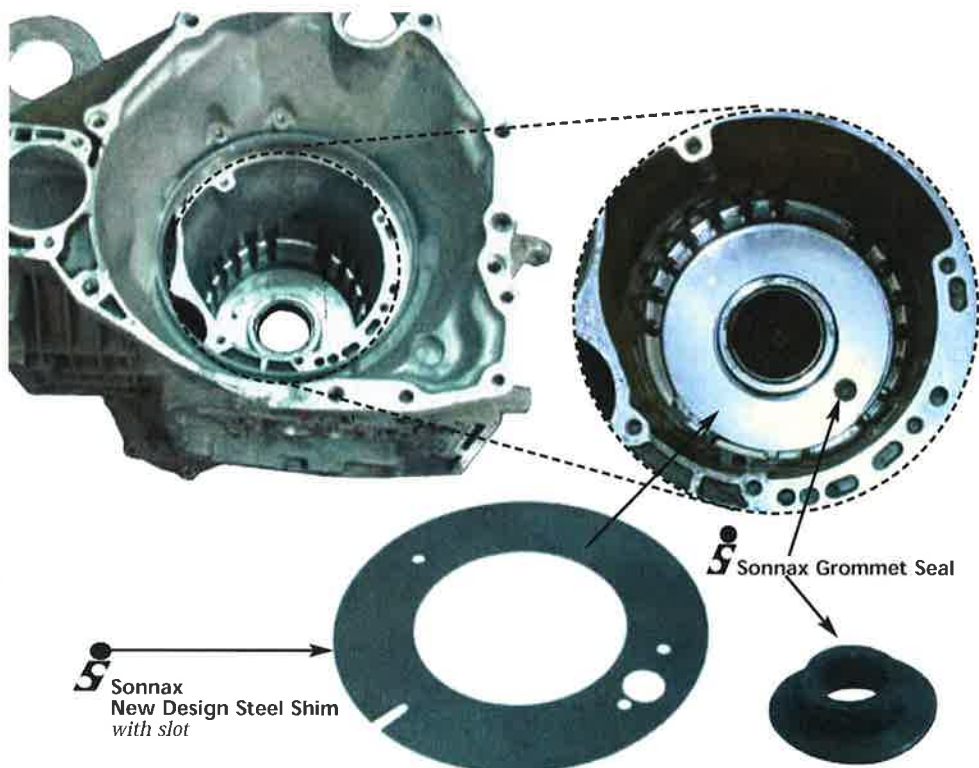

## STEP 9 INSTALL TRANSFER/OUTPUT SHAFT GEAR SHIMS (41TE ONLY)

### For the output bearing set-up:

Place a gauging shim (OEM is .177") on the planetary carrier at the step below the spline area. Torque the output gear nut to 200 ft. lbs. The final set-up should obtain a turning torque of 3-8 inch lbs and a bearing preload of  $-.0008"$  to  $-.002"$ , with the minus designating preload. If the turning torque is too high, add enough Sonnax shims and/or spacers to reach the proper specifications. The output gear should be set up without the transfer shaft assembled.

### For the transfer shaft bearing set-up:

Place a gauging shim (OEM is .184") on the shaft. Torque the transfer gear nut to 200 ft. lbs. Measure the gear endplay with a dial indicator and add or subtract enough Sonnax shims and/or spacers until a gear endplay of  $.002"$  to  $.004"$  is obtained.

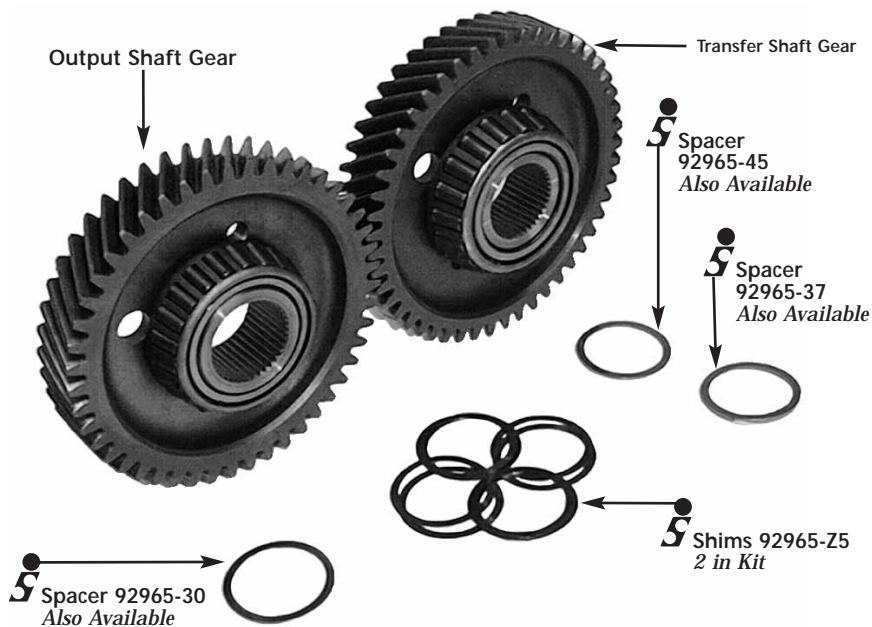

## STEP 10 INSTALL DIFFERENTIAL PRELOAD SHIM

1. Install a spacer and shim combination to obtain a  $.010"$  or less endplay.
2. With the differential assembly in the transmission, mount a dial indicator with the end contacting the side of the ring gear.
3. Move the differential ring gear from side to side. Note the reading on the dial indicator.
4. Install the correct number of **39539-Z5** or **39540-Z5** shims to obtain a bearing preload of  $-.006"$  to  $-.011"$ .
5. To verify proper preload, rotational torque should be 5-18 in./lbs.

**Note:** To remove and replace the differential bearing retainer oil seal and bearing retainer cups, use the recommended Chrysler tools and procedures.

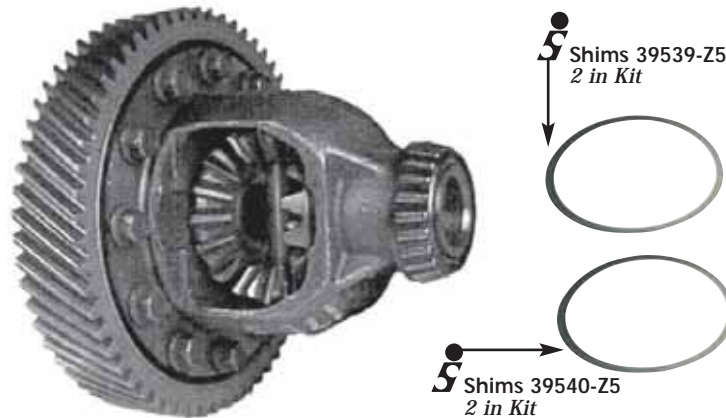

## STEP 11 INSTALLING FRONT PUMP BUSHING

- 1) Remove the worn bushing from the pump housing using an appropriate bushing driver.
- 2) Inspect the pump housing bore for any damage. Also inspect the torque converter hub for signs of wear. The hub diameter should be no less than 1.497".
- 3) Using the correct size bushing driver press in the Sonnax replacement bushing.
- 4) **VERY IMPORTANT!** Due to inconsistent pump bushing bores, this bushing may be too tight. Check converter hub-to-pump bushing clearance after installation. Ideally, clearance should be  $.003"$ -. $.005"$ . **DO NOT use the Sonnax bushing if the clearance is  $.002"$  or less.**
- 5) Stake the bushing in the two notched locations. Be careful not to raise the I.D. surface of the bushing.

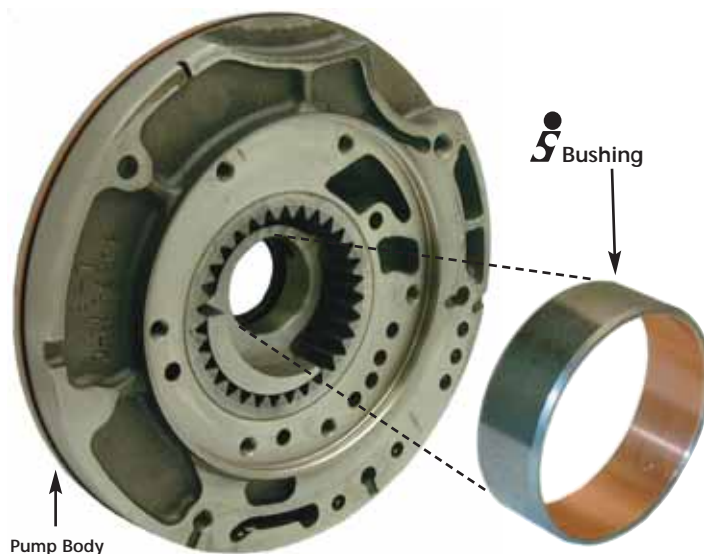

**Check converter hub to pump bushing clearance after installation. Ideally, clearance should be  $.003"$ -. $.005"$ . Do not use the Sonnax bushing if the clearance is  $.002"$  or less.**

**Harsh Engagement**

- |    |                                    |                             |
|----|------------------------------------|-----------------------------|
| #1 | Pressure regulator reducing sleeve | Inspect/ air test sleeve    |
| #2 | End plug leak at reducing sleeve   | Inspect for fit/ air test   |
| #3 | Valve body halves warped           | Resurface case and castings |
| #4 | Valve body bolts too loose         | Torque to 75" lbs.          |
| #5 | Poor print pattern on plate        | Resurface, retorque         |

**Engagement Shudder**

- |     |                                      |   |
|-----|--------------------------------------|---|
| #6  | Loose filter, low oil level          | Install lightweight spring around magnet between pan and filter to push o-ring into body  |
| #7  | Test oil pressure at low reverse     | Pressure should be 180-240  |
| #8  | Separator plate not aligned          | Use alignment pins on slotted holes   |
| #9  | Low reverse accumulator leak         | CVI's range @ 38-70, air test   |
| #10 | Low reverse clutch leakage           | V.B. guide tube position, air test  |
| #11 | Cross leakage at input sealing rings | Air test with input hub assembled onto pump. No cross leakage between circuits. If leakage occurs, resurface stator to pump surface, sealing ring grooves, the I.D. of input hub with ScotchBrite™ and re-ring with solidPTFE rings (from 4L80-E center support). |
| #12 | Underdrive clutch leakage            | UD accumulator bore and seal wear<br>UD clutch psi. should be 100-140   |

**Upshift Shudder**

- |      |                                |  |
|------|--------------------------------|--|
| #13  | Identify the clutch of concern | Use pressure gauge, tapped into both the clutch releasing and clutch being applied. Identify psi. spikes or low oncoming pressure, as in note #12. Drive in OD range and Drive range to isolate OD clutch.   |
| #14  | Inspect accumulator bores      | 1-2 or 3-4 shudder, inspect valve body accumulator bore for wear. 2-3 shudder, inspect case bores of accumulators.   |
| #15  | Air test 2-4 clutch circuit    | 2-4 clutch seal on top of valve body can be shimmed upward with flat washer to increase seal pressure on housing. If excess leakage from 2-4 clutch, the housing stamped bleed hole at top may be too large. Re-crimp OEM shut and re-drill to .045" to .052" max. |
| #16  | Pressure rise concern          | Filter, pump capacity, pressure regulator reducing sleeve worn, bypass valve in case sticking open, resurface case and valve body. Check line psi. as in #12.  |
| #17  | Clutch hub cross leak          | Use air test plate bolted to case surface, or test at ports during assembly. No cross leaks during sealing ring air test. See note #11.  |
| # 18 | Accumulator springs            | Firmer clutch apply and upshift requires higher spring rate, additional inner spring or shims.   |

**Bump**

- |     |               |  |
|-----|---------------|--|
| #19 | 4-3 downshift | 2-4 clutch is releasing, UD clutch is applying. Check clutch clearance, CVI, cross leakage and UD accumulator bore. Verify clutch psi. cutback; Pressure ports are:UD tap/ nearest bell housing and OD 2nd of left. Drive in OD range and D range with gauge on the UD tap.<br>UD clutch in 2nd gear = 100-140<br>UD clutch in 3rd gear = 75-90<br>UD clutch in 4th gear = 0-2<br>OD clutch in 2nd gear = 0-2<br>OD clutch in 3rd gear = 75-90<br>See note # 12 and 13<br>A bump on 4-3 may occur as UD clutch psi. ramps up from initial 0 to 35 psi. The faster the apply psi. rise, the firmer the bump. If clutch psi. is OK, reduce the spring rate of UD accumulator (nearest solenoid). |
| #20 | 4-2 downshift | Verify 2-4 clutch psi. does not release.<br>2-4 clutch psi. tap is second from right.<br>2-4 psi. should be 75-90 in 4th, 0-2 in 3rd if clutch were to disengage and 120-145psi. during 4-2nd shift.<br>2-4 clutch is remaining on, OD clutch is coming off and UD clutch is applying. See note #11 and #12.   |
| #21 | 3-2 downshift | See notes #11,14,15,17,18, 20  |
| #22 | 2-1 downshift | 2-4 clutch is releasing, UD clutch remains applied and low-reverse applies. Inspect low-reverse accumulator bore. Verify pressure at right tap @ 120-140 on 2-1 shift. See notes #1 to 5, 9,10,11  |

**PREVENTIVE REBUILD PROCEDURES**

Many concerns can be eliminated by completing the steps in notes #1-6, 8,10,11,14,15,16.

*Note: Clutch pressures should be within 10 psi of each other when comparing two applied clutches at same time. A cross leak will show up in an exhausted/unapplied clutch as pressures over 5 psi. Very low CVI and bump shifts or erratic codes and limp mode are often related to hard seals or cross leaks at the hub or pump surface. Refer to the information on the 92835-01K converter regulator valve for converter regulation cross leaks.*