



East Coast Metal Roofing, LLC.
254 Sutton Ave, Oxford, MA 01540
Tel: 844-611-3267`
eastcoastmetalroofing.com

Somerville Historic,

East Coast Metal Roofing is contracted to strip the existing roof, install ice & water shield, and install Permalock roofing system.

Before & After
197 Morrison Ave, Somerville, MA 02144





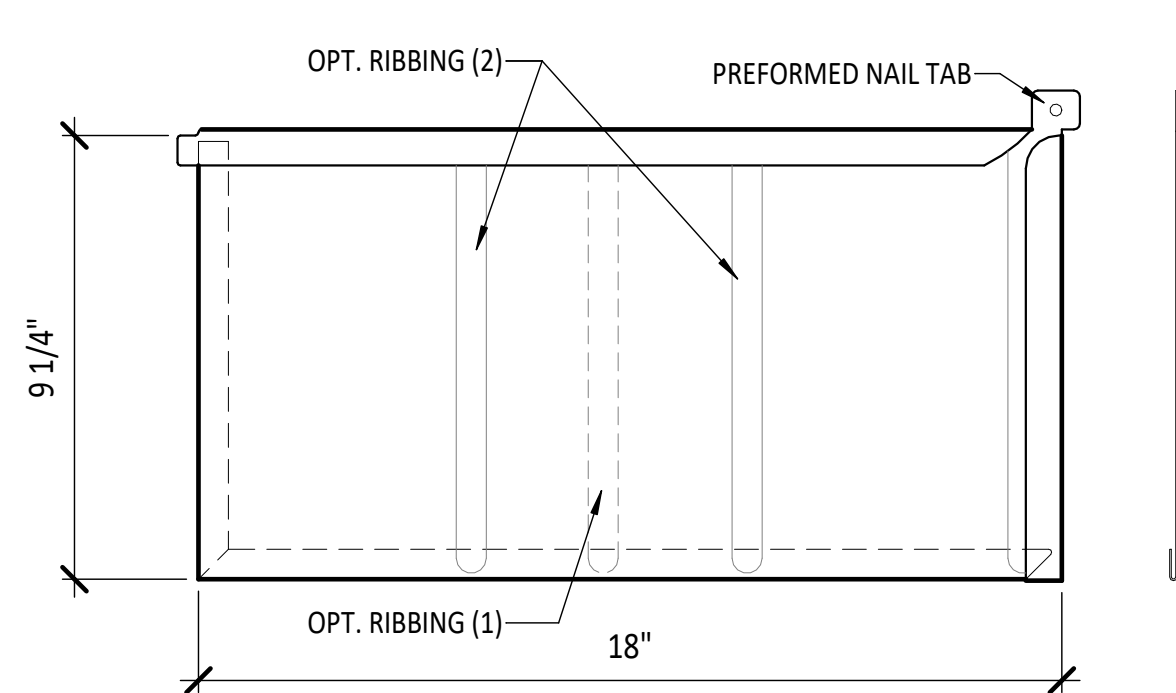

1 "Perma-Lock" Shingle with Profile
SCALE: 3" = 1'-0"

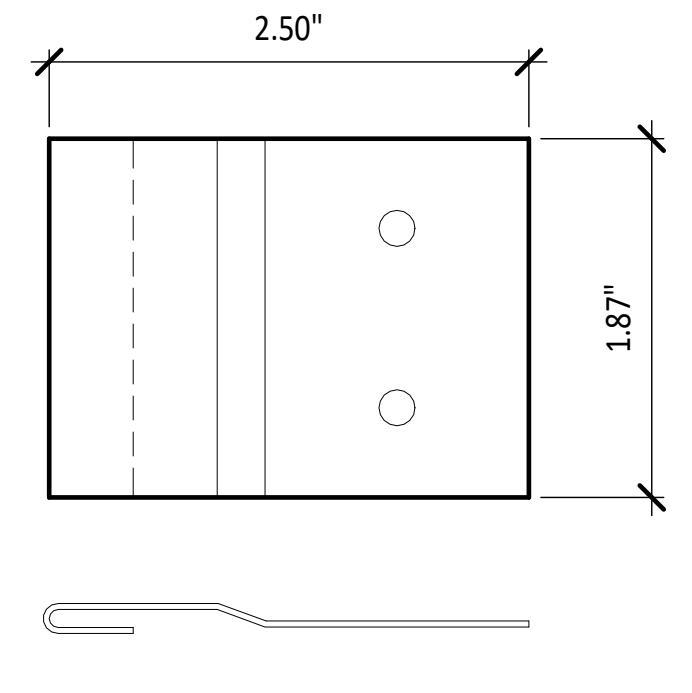

2 Panel Clip with Profile
SCALE: 12" = 1'-0"

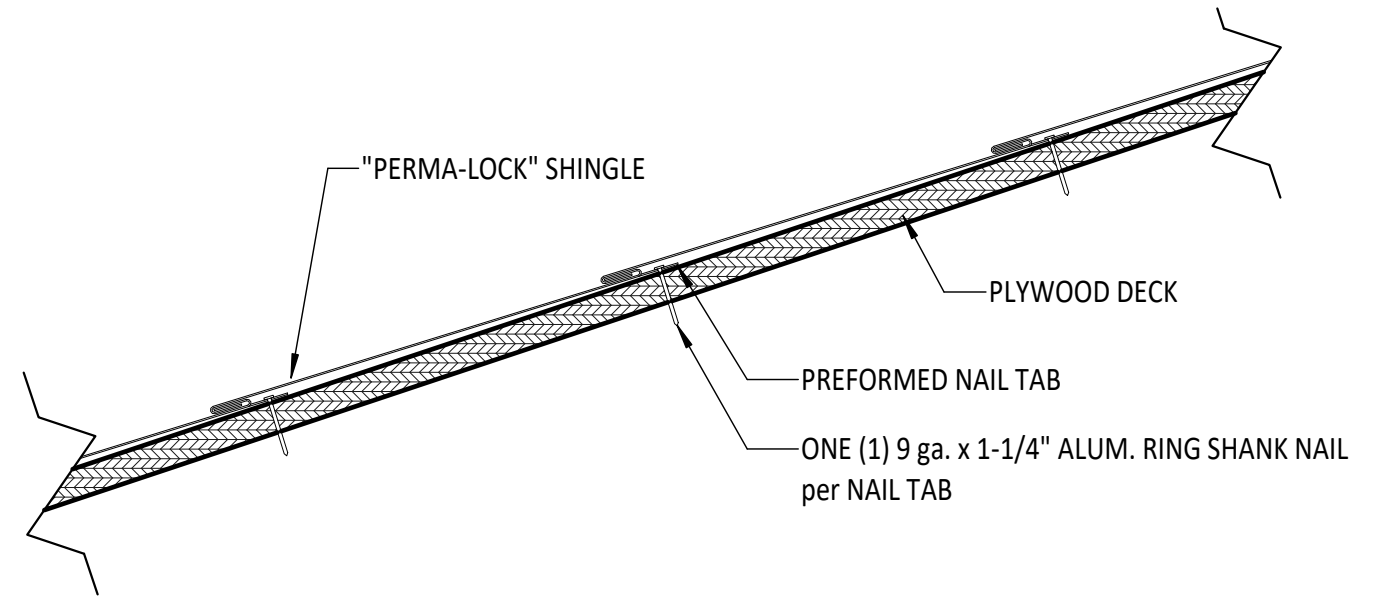

3 Shingle Installation - SECTION (1)
SCALE: 3" = 1'-0"

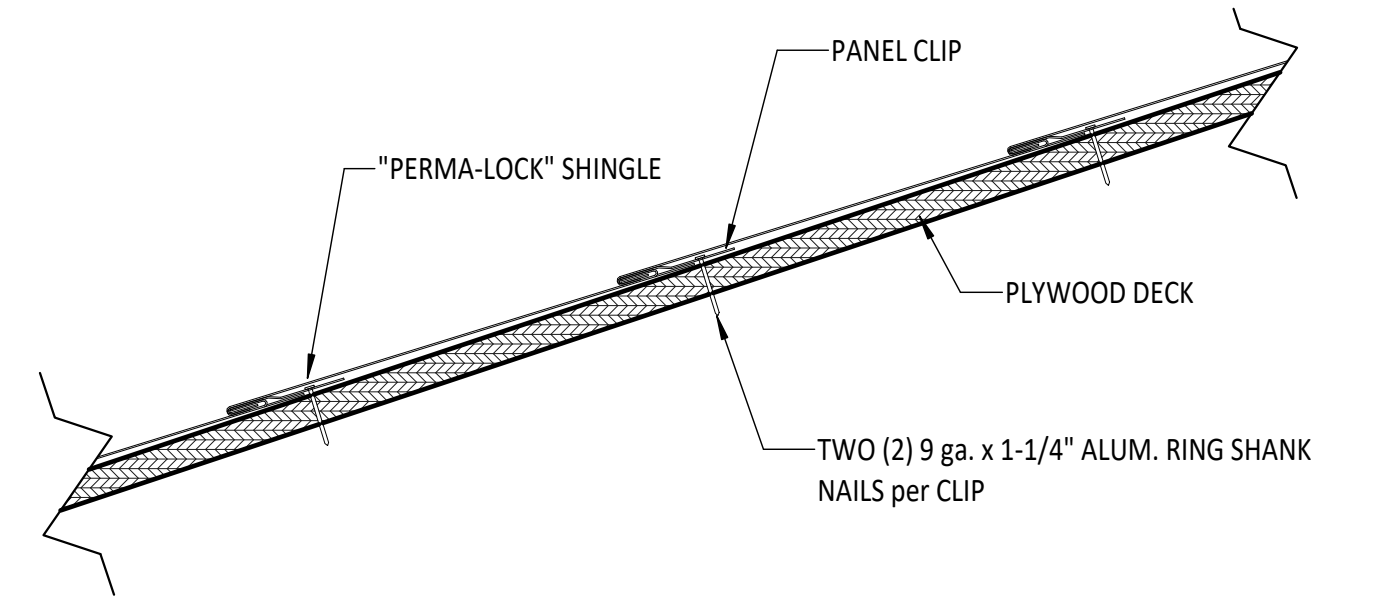

5 Shingle Installation - SECTION (2)
SCALE: 3" = 1'-0"

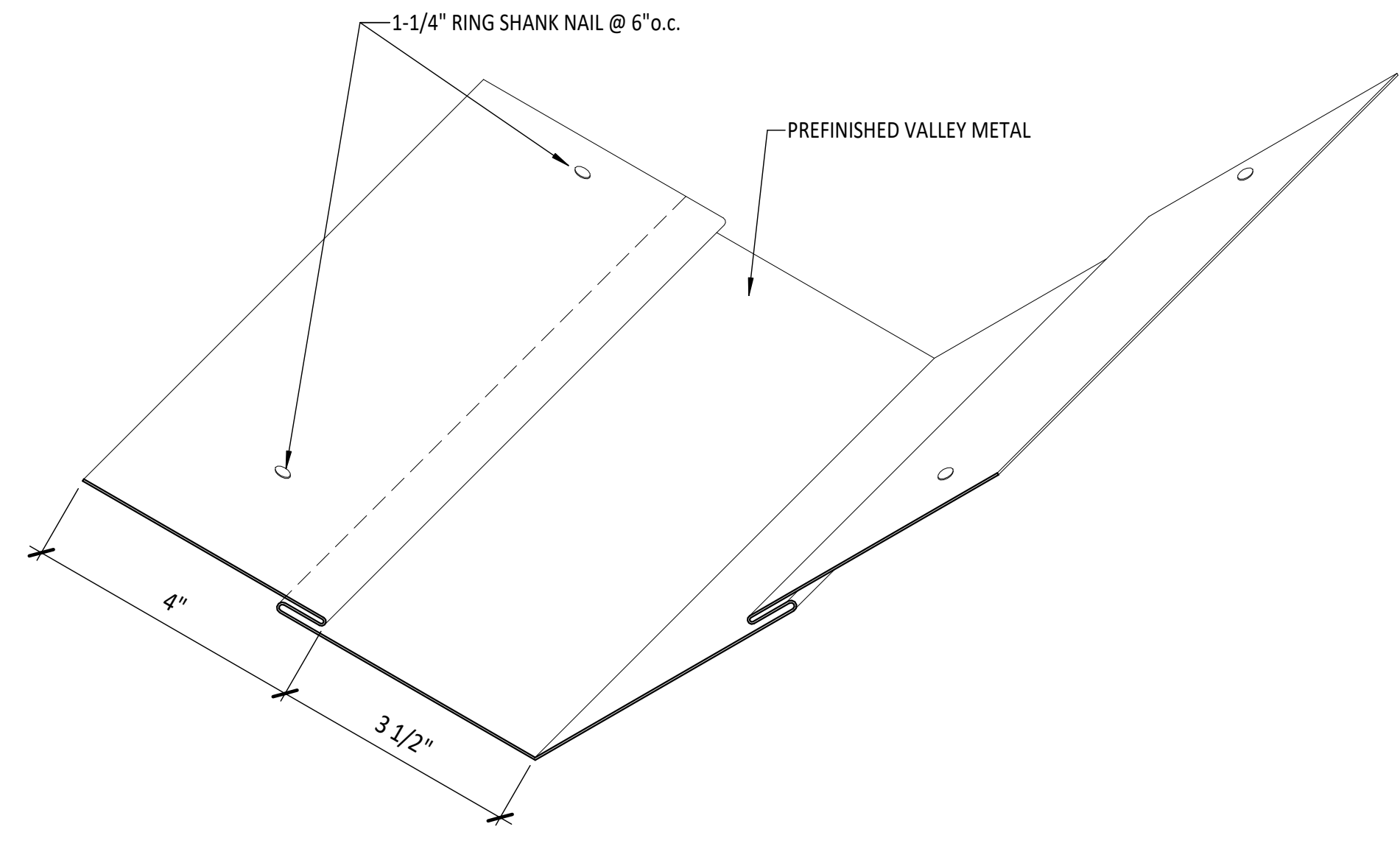

7 VALLEY FLASHING
SCALE: 6" = 1'-0"

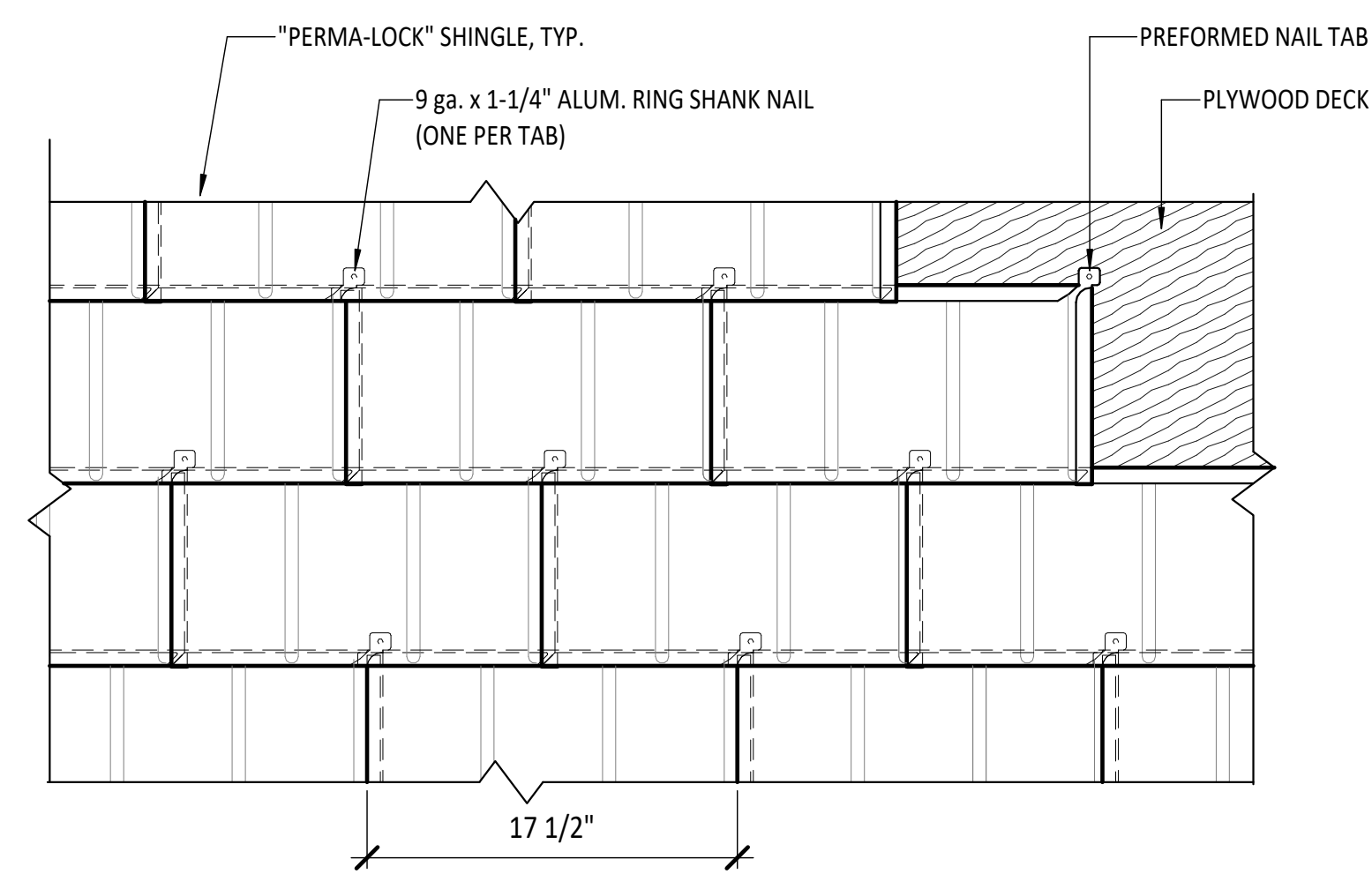

4 Shingle Installation - PLAN (1)
SCALE: 1 1/2" = 1'-0"

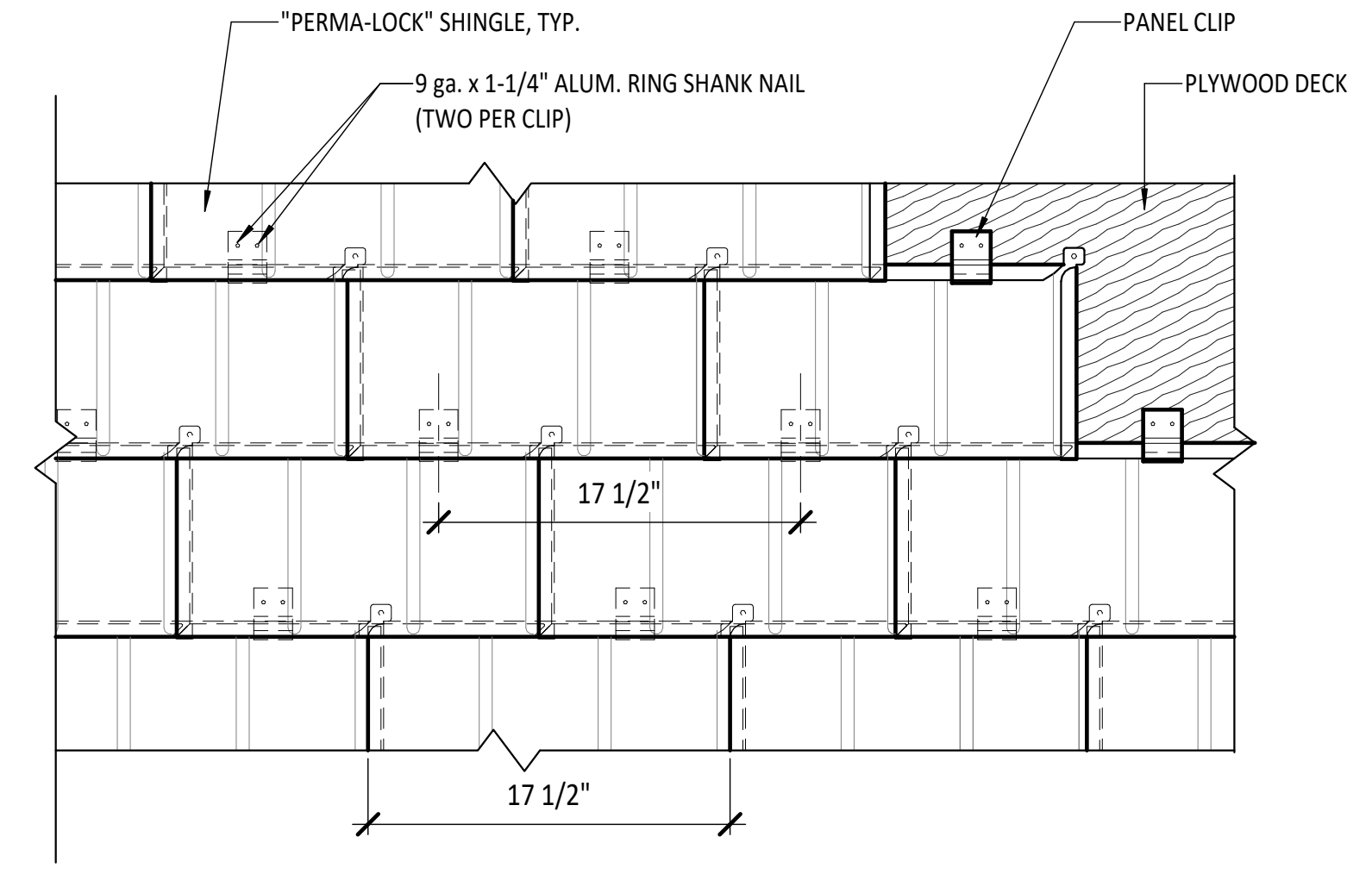

6 Shingle Installation - PLAN (2)
SCALE: 1 1/2" = 1'-0"

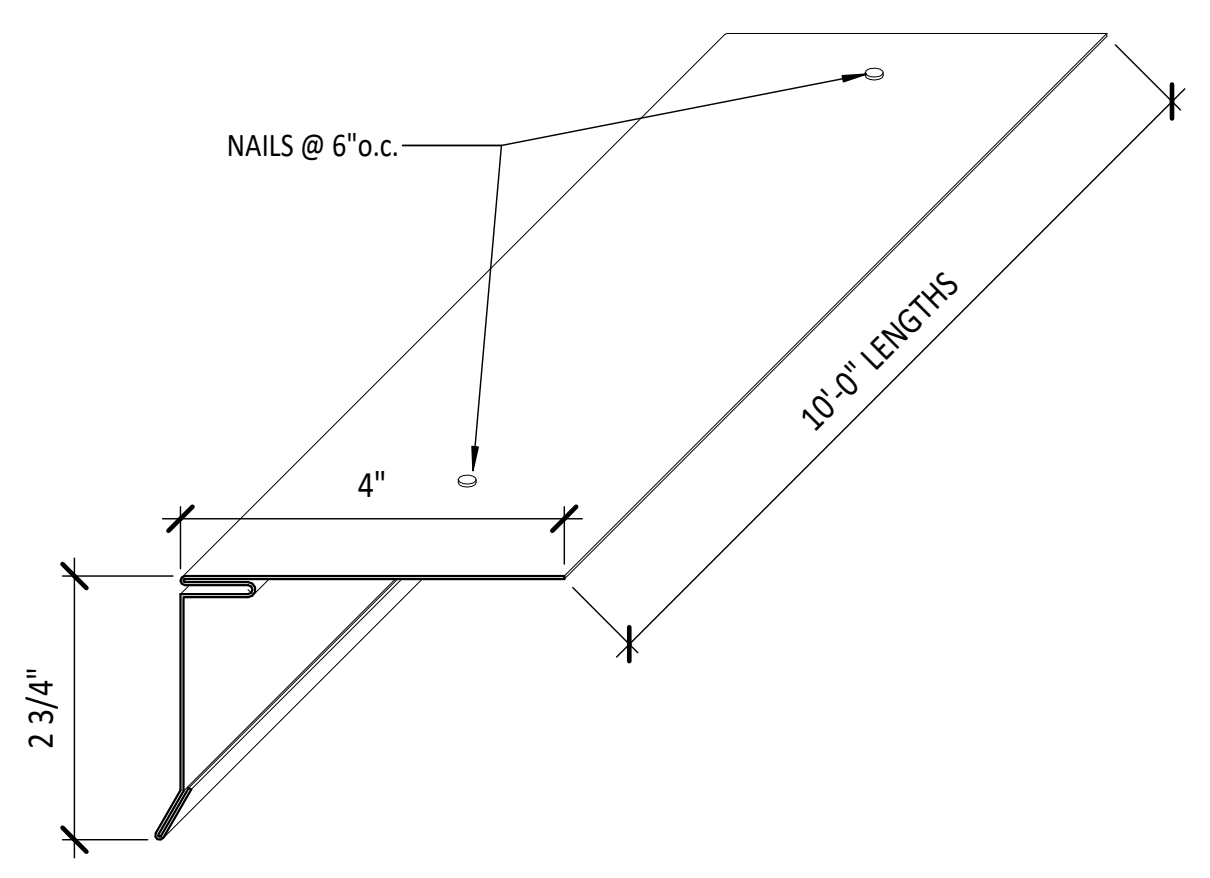

8 Eave Starter Flashing
SCALE: 6" = 1'-0"

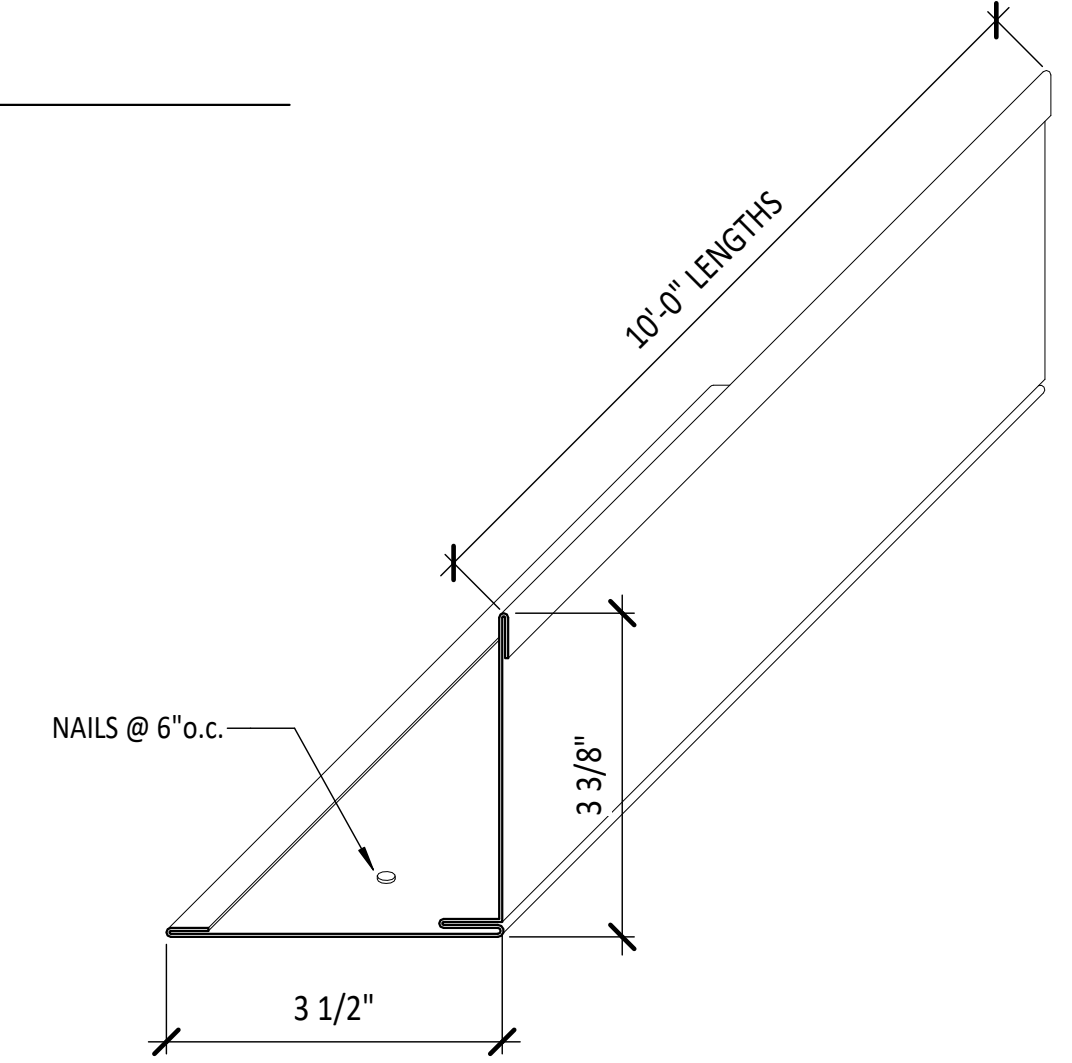

10 Chimney Flashing
SCALE: 6" = 1'-0"

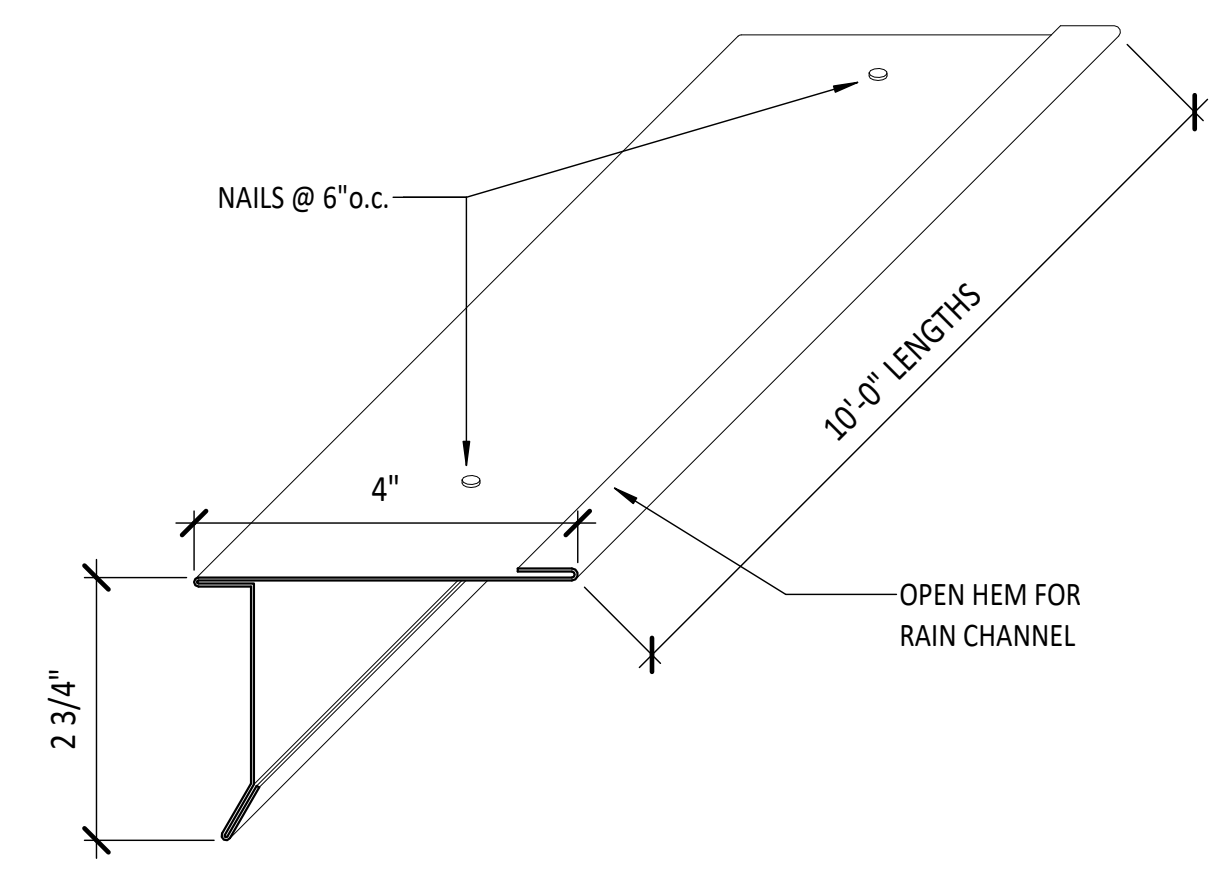

9 Rake Flashing
SCALE: 6" = 1'-0"

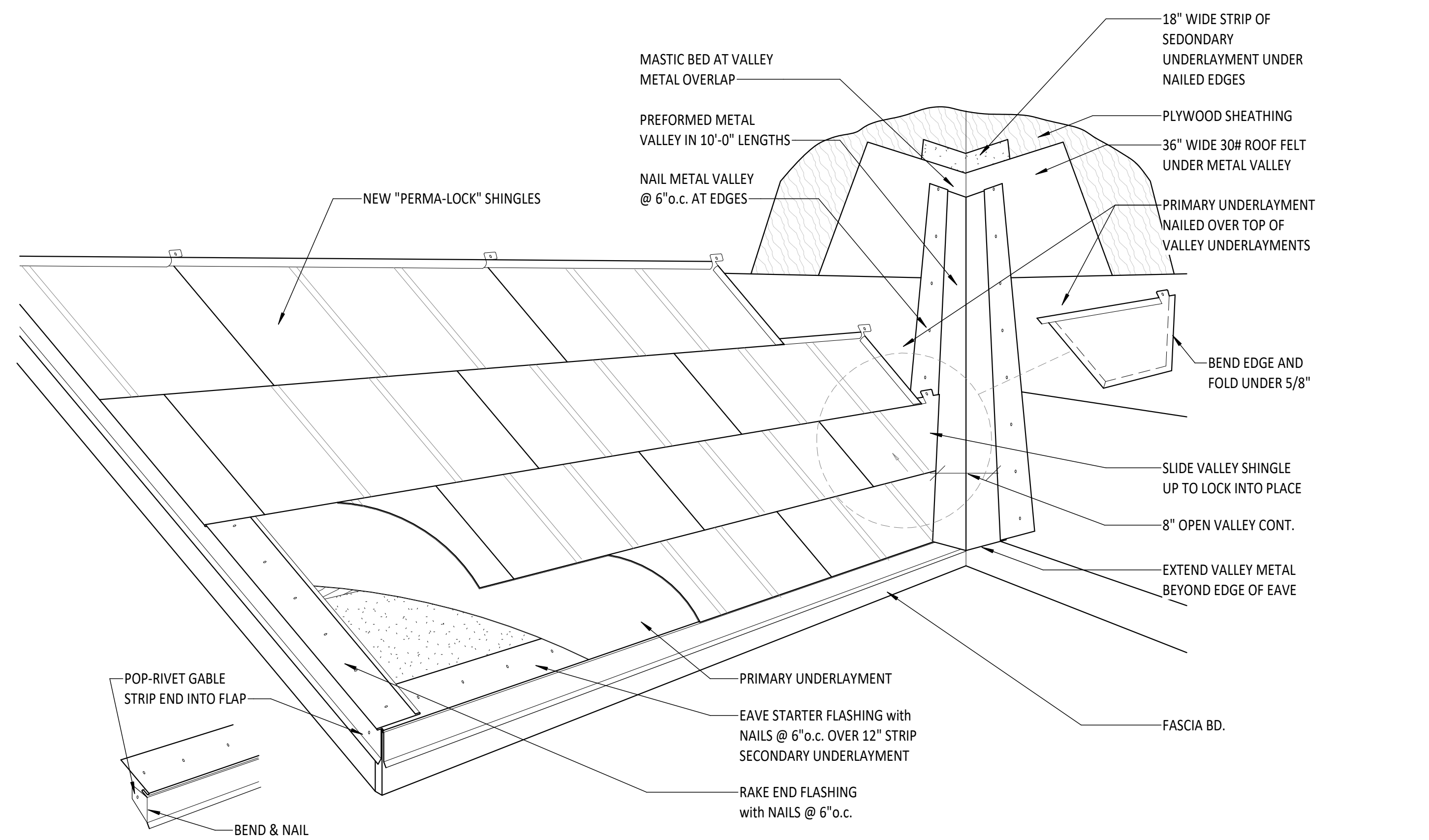

11 Valley Assembly Detail
SCALE: 1" = 1'-0"

REVISIONS	DESCRIPTION	DATE

PROJECT NO.	Project Number
DRAWN BY	Author
CHECKED BY	Approver
DATE	11/30/09
PROP. NO.	#

SHINGLE SYSTEM DETAILS
A5.01















STAR
WASTE SYSTEMS

53



METAL SHINGLES: Perma Lock Aluminum

1.GENERAL

1. SUMMARY

A.Includes But Not Limited To:

1. Furnish and install metal shingle roofing system as described in Contract Documents including but not limited to:
 - a. Metal shingles and accessories.
 - b. Counter flashings.
 - c. Fasteners.
 - d. Formed metal and drip edge.
 - e. Pipe flashing for vent piping and flues.
 - f. Roof jacks.
 - g. Saddles and curb flashings.
 - h. Sealant.
 - i. Underlayment.

2. REFERENCES

A.Association Publications:

1. American Architectural Manufacturers Association (AAMA):
 - a. 'Voluntary Specifications and Test Methods for Sealants'.
2. ASM International:
 - a. 'Adhesives and Sealants', Volume 3, ASM International Handbook Committee, (May 1999).
 - b. Committee C24 on Building Seals and Sealants for various Specifications, Guides, Test Methods, and Practices related to sealant specifying and application.
 - c. Committee E6 on Building Performance for various Specifications, Guides, Test Methods, and Practices related to sealant use with air barriers, vapor retarders, and exterior enclosure systems and materials.
3. The Adhesive and Sealing Council, Inc. (ASC) / Sealant, Waterproofing & Restoration Institute (SWR Institute):
 - a. 'Sealants: The Professional's Guide'.
 - b. 'Joint Sealants, Whole Building Design Guide'.

B.Definitions:

1. Base Flashing: That portion of flashing attached to or resting on roof deck to direct flow of water onto the roof covering.
2. Cap Flashing: Material used to cover top edge of base flashings or other flashings to prevent water seepage behind base flashing. Cap flashing overlaps base flashing.
3. Collar: Pre-formed flange placed over vent pipe to seal roof around vent pipe opening. Also called vent sleeve.
4. Deck: Structural component of roof of building which provides substrate to which roofing system is applied.
5. Drip Edge: Non-corrosive, non-staining material used along eaves and rakes to allow water run-off to drip clear of underlying building.
6. Flame Spread Classification: Categories as per ASTM E84/UL 723 or CAN/ULC-S102-10:
 - a. Class A: Highest fire-resistance rating for roofing as per ASTM E108. Indicated roofing is able to withstand severe exposure to fire exposure to fire originating from sources outside building.
 - b. Class B: Fire-resistance rating indicating roofing materials are able to withstand moderate exposure to fire originating from sources outside of building.
 - c. Class C: Fire-resistance rating indicating roofing materials are able to withstand light exposure to fire originating from sources outside of building.
7. Flange: Metal pan extending up and down roof slope around flashing pieces. Usually at plumbing vents.

8. Flashing: Components used to prevent seepage of water into a building around any intersection or projection in a roof such as vent pipes, chimneys, adjoining walls, dormers and valleys.
9. Four Wind Zones (Florida Building Code):
 - a. Special Protection Zone.
 - b. High Velocity Hurricane Zone (HVHZ): Miami-Adde and Broward counties.
 - c. Wind-Borne Debris Region.
 - d. Panhandle Protection Provision Zone.
10. Galvalume: Trade name for protective coating composed of aluminum zinc.
11. Ice Dam: Condition formed at lower roof edge by thawing and re-freezing of melted snow on roof overhang. Ice dams force water to 'back up' under shingles, causing leakage.
12. Interlocking shingles: Individual shingles that mechanically fasten to each other to provide wind resistance.
13. Lap: Part of roofing material that overlaps section of adjacent material.
14. Life Safety Code Classes (NFPA 101):
 - a. Class A: rating 0-25.
 - b. Class B: rating 26-75.
 - c. Class C: rating 76-200.
 - d. Class D: rating 201-500.
 - e. Class E: rating over 500.
15. Metal Flashing: Roof components made from sheet metal that is used to terminate roofing membrane or other material alongside roof perimeters as well as at roof penetrations.
16. Penetration: Any object that pierces surface of roof.
17. Pipe Boot: Prefabricated flashing piece used to flash around circular pipe penetrations. Also known as Roof Jack.
18. Roof Assembly: System of interacting roof components (including roof deck) designed to weatherproof, and normally, to insulate building's top surface.
19. Underlayment:
 - a. Secondary Underlayment (Ice and Water Shield): Rubberized asphalt membrane with peel off backing that adheres to roof deck creating waterproof seal installed under roofing material meeting requirements of ASTM D1970/D1970M. Degrades with exposure to UV light. Due to its consistency, seals around roofing nails.
20. Valley: Internal angle formed by intersection of two sloping roof planes to provide water runoff.
21. Vent: Any outlet for air that protrudes through roof deck such as pipe or stack. Any device installed on roof, gable or soffit for purpose of ventilating underside of roof deck.
22. Vent Sleeve: See collar.
 - a. Hurricane-Prone Regions: Areas vulnerable to hurricanes defined as:
 - 1) U.S. Atlantic Ocean and Gulf of Mexico coasts and Hawaii where basic wind speed is greater than 90 mph (40m/s).
 - b. Wind-Borne Debris Region: Portions of hurricane-prone regions that are within 1 mile (1.61 km) of coastal mean high water line where basic wind speed is 110 mph (48 m/s) or greater, or Hawaii.
23. Wind Uplift: Wind-induced forces on roof system or components in roof system. Wind uplift generally includes negative pressure component caused by wind being deflected around and across surfaces of building and positive pressure component from air flow beneath roof deck.

C. Reference Standards:

1. ASTM International:
 - a. ASTM A167-99(2009), 'Standard Specification for Stainless and Heat-Resisting Chromium-Nickel Steel Plate, Sheet, and Strip'.
 - b. ASTM B209-10, 'Standard Specification for Aluminum and Aluminum-Alloy Sheet and Plate'.
 - c. ASTM C719-93(2010), 'Standard Test Method for Adhesion and Cohesion of Elastomeric Joint Sealants Under Cyclic Movement (Hockman Cycle)'.
 - d. ASTM C920-11, 'Standard Specification for Elastomeric Joint Sealants'.
 - e. ASTM D1970/D1970M-11, 'Standard Specification for Self-Adhering Polymer Modified Bituminous Sheet Materials Used as Steep Roofing Underlayment for Ice Dam Protection'.
 - f. ASTM D2244-11, 'Standard Practice for Calculation of Color Tolerances and Color Differences from Instrumentally Measured Color Coordinates'.
 - g. ASTM D4214-07, 'Standard Test Methods for Evaluating the Degree of Chalking of Exterior Paint Films'.
 - h. ASTM E84-12c, 'Standard Test Method for Surface Burning Characteristics of Building Materials'.
 - i. ASTM E108-11, 'Standard Test Methods for Fire Tests of Roof Coverings'.

- j. Coverings'.
- k. ASTM F1667-11a, 'Standard Specification for Driven Fasteners: Nails, Spikes, and Staples'.
- 2. Federal Specifications:
 - a. TT-S-00230C (CON-NBS), 'Sealing compound: Elastomeric Type, Single Component (For Calking, Sealing, And Glazing In Buildings And Other Structures.' (2 Feb 1970).
- 3. Florida Building Code (FBC), Tallahassee, FL www.floridabuilding.org:
 - a. Section 1506, 'Materials':
 - 1) 1506.2, 'Compatibility of Materials'.
 - 2) 1506.5, 'Nails'.
 - 3) 1506.7, 'Clips'.
 - b. Section 1507, 'Requirements For Roof Coverings':
 - 1) 1507.4, 'Metal Roof Panels'.
 - a) 1507.4.1, 'Deck Requirements'.
 - b) 1507.4.2, 'Deck Slope'.
 - c) 1507.4.3, 'Material Standards'.
 - d) 1507.4.4, 'Attachment'.
 - e) 1507.4.5, 'Underlayment'.
 - c. Section 1626.1, HVHZ – Impact Test for Wind-Bourn Debris' (2007 Code).
 - d. Testing Application Standard:
 - 1) TAS No. 100-95, 'Test Procedure For Wind And Wind Driven Rain Resistance Of Discontinuous Roof Systems'.
- 4. International Building Code (IBC):
 - a. Chapter 15, 'Roof Assemblies And Rooftop Structures':
 - 1) Section 1506, 'Materials'.
 - a) 1506.2, 'Compatibility of Materials'.
 - 2) Section 1507, 'Requirements for Roof Coverings'.
 - a) 1507.5, 'Metal Roof Shingles'.
 - (1)1507.5.1, 'Deck Requirements'.
 - (2)1507.5.3, 'Underlayment'.
 - (3)1507.5.4, 'Ice Barrier'.
 - (4)1507.5.5, 'Material Standard'.
 - (5)1507.5.6, 'Attachment'.
 - (6)1507.5.7, 'Flashing'.
 - b. Chapter 16, 'Structural Design'.
 - 1) Section 1609 'Wind Loads'.
 - a) 1609.3, 'Basic Wind Speed'.
- 5. International Code Council Evaluation Services (ICC-ES):
 - a. AC48, 'Acceptance Criteria For Roof Underlayment for Use in Severe Climate Areas' (Approved February 2012).
 - b. AC166, 'Acceptance Criteria For Metal Roof Coverings' (February 2011).
 - c. AC188, 'Acceptance Criteria For Roof Underlayments' (Approved February 2012).
 - d. ICC/ESR- 2206, 'CCW WIP 300HT, CCW WIP 400, CCW 403HR, and CCW 401 LT Roof Underlayments' (Reissued March 1, 2012).
- 6. National Fire Protection Association:
 - a. NFPA 101: 'Life Safety Code' (2012 edition).
- 7. Underwriters Laboratories (UL):
 - a. UL 580: 'Tests for Uplift Resistance of Roof Assemblies' (5th Edition).
 - b. UL 723, 'Tests for Safety Test for Surface Burning Characteristics of Building Materials' (10th Edition).
 - c. UL 790, 'Standard Test Methods for Fire Tests of Roof Coverings' (8th edition).
 - d. UL 1897-04, 'Uplift Tests for Roof Covering Systems' (6th edition).
 - e. UL 2218, 'Standard for Impact Resistance of Prepared Roof Coverings Materials' (2nd Edition).
- 8. Underwriters Laboratories of Canada:
 - a. CAN/ULC S102-10: 'Method of Test for Surface Burning Characteristics of Flooring, Floor Coverings, and Miscellaneous Materials and Assemblies' (7th Edition).
 - b. CAN/ULC S107-03 (UL 790): 'Methods of Fire Tests of Roof Coverings' (3rd Edition).

3. QUALITY ASSURANCE

A.Regulatory Agency Sustainability Approvals:

1. Building Codes:
 - a. Roof system will meet requirements of all federal, state, and local codes having jurisdiction.
 - b. Meet requirements for NFPA 101 Class A roof assembly.
2. Fire Resistance:
 - a. Provide metal shingles and related roofing materials with fire-test-response characteristics indicated, as determined by testing identical products per test method indicated below by UL / ULC or another testing and inspecting agency acceptable to authorities having jurisdiction. Identify materials with appropriate markings of applicable testing and inspecting agency:
 - 1) Exterior Fire-Test Exposure: Class A; UL 790 or ASTM E108, for application and roof slopes indicated.
 - 2) Exterior Fire-Test Exposure: Class A, ULC S102 or ASTM E108, for application and roof slopes indicated.
3. Impact Resistance:
 - a. Shingles:
 - 1) Meet UL 2218 Class 4 impact resistant rating.
4. Florida Certificate of Product:
 - a. Metal Shingles:
 - 1) Florida Certificate of Product, Approval No. FL14667.1-R1 (approval 04/08/2013).
5. Uplift Resistance:
 - a. Shingles:
 - 1) Meet UL 580 wind uplift.
6. Wind Speed:
 - a. As required to meet local codes having jurisdiction.
 - 1) Installation shall comply with IBC 1507.5.6 'Attachment'.

B. Qualifications:

1. Manufacturer:
 - a. Roof panels produced under quality control program with inspections by Underwriter Laboratories, Inc. (AA-668).
2. Installers:
 - a. Requirements of Section 01 4301 applies but not limited to the following:
 - 1) Approved and authorized by Roofing Manufacturer to install Manufacturer's product and eligible to receive Manufacturer's warranty before bid.
 - 2) Minimum three (3) satisfactorily completed installations of comparable quality, scope, similar size, and complexity in past two (2) years before bidding.
 - a) List of roofing installations performed by certified installer, and their addresses.
 - 3) Current license for the city, county, and state where project is located and license for specific type of roofing work to be performed.
 - 4) Roofing Installer's foreman shall be skilled in his trade and qualified to lay out and supervise the Work.
 - 5) Flashing installation shall be performed by personnel trained and authorized by Roofing Manufacturer.
 - 6) Provide documentation if requested by Architect:

4. DELIVERY, STORAGE, AND HANDLING

A. Delivery And Acceptance Requirements:

1. Make no deliveries to Project until installation is about to commence, or until approved storage area is provided.
2. Deliver products job site in original unopened containers or wrappings bearing all seals and approvals.
3. Deliver materials in sufficient quantities to allow continuity of work.
4. Remove any material not approved from job site.

B. Storage And Handling Requirements:

1. Storage Requirements:
 - a. General:
 - 1) Follow Manufacturer's instructions and precautions for storage of materials.
 - 2) Protect roof materials from physical damage, moisture, soiling, and other sources in a clean, dry, protected location.
 - b. Underlayment:

- 1) Store materials protected from exposure to harmful weather conditions at temperatures within tolerances allowed.
- c. Unacceptable Material:
 - 1) Remove from job site materials that are determined to be damaged by Architect or by Roofing Manufacturer and replace at no additional cost to Owner.
2. Handling Requirements:
 - a. Handle rolled goods so as to prevent damage to edge or ends.

5. FIELD CONDITIONS

A.Ambient Conditions:

1. Temperature ranges shall be within tolerances allowed for material being used.
 - a. Cold temperature:
 - 1) Follow Manufacturer's instructions for cold temperature installation.

6. WARRANTY

A.Manufacturer Special Warranty:

1. Material Warranty:
 - a. Material warranty will be covered at one hundred (100) percent by Aluminum Shingle Manufacture for duration of time homeowner owns building.
 - b. Aluminum Shingles are free from manufacturing defects in material and workmanship.
 - c. Aluminum Shingles will not burn or support combustion, split or crack due to cold weather, rust, lose impact resistance with age, or be perforated by hail.
 - d. Roofing System will withstand winds up to **165 mph (209 km/hr)** average wind speed.
2. Manufacturer's Finish Warranty:
 - a. Manufacturer's thirty (30) year warranty covering from date of installation:
 - 1) Kynar 500/Hylar 5000 finish will:
 - a) Not chip, peel, flake, or blister under conditions of ordinary wear.
 - b) Not fade or change color in excess of seven (7) Hunter E units.
 - c) Color change determination by ASTM D2244 procedure comparing an unexposed panel to exposed panel after removal of dirt and chalk.
 - d) Not chalk in excess of ASTM D4214 rating.

2.PRODUCTS

1. SYSTEMS

A.Manufacturers:

1. Metal Shingles:
 - a. Category Four Approved Manufacturers. See Section 01 6200 for definitions of Categories:
 - 1) Aluminum Shingle Company, Portland, OR www.aluminumshingle.com.
 - a) Contact Information: (office) (877) 319-7999 (cell) (801) 633-1259 (email) info@aluminumshingle.com.

B.Materials:

1. Design Criteria:
 - a. This specification sets minimum standards for materials and workmanship.
 - b. Governing building codes shall apply where they impose higher standards.
2. Shingles:
 - a. Design Criteria:
 - 1) Aluminum roofing panels.
 - a) Alloy Type: 3105-H24 (in compliance with ASTM B209).
 - b) Yield Strength: **18 ksi (124 MPa)** minimum.
 - c) Tensile Strength: **22 ksi (152 MPa)** minimum. **29 psi (200 MPa)** maximum.
 - d) Corrosion Resistance: In compliance with FBC Section 1507.4.3, 'Material Standards' (table 1507.4.3(2) minimum corrosion resistance).

- e) Treat both sides of panels with corrosion inhibiting coating.
 - f) Thickness: **0.019 inch (0.48 mm)** minimum (in compliance with ASTM B209).
 - g) Panel Dimensions: **9-1/4 inch (235 mm) x 18 inch (457 mm)**.
 - 2) Meet requirements for NFPA 101 Class A roof assembly.
 - 3) Fire resistance for exterior fire test exposure: Class A; UL 790, ULC S102, or ASTM E108.
 - 4) Meet UL 580 wind uplift.
 - 5) Meet UL 2218 Class 4 impact resistant rating.
 - 6) Ridges, rakes, and hips to be Manufacturer's standard products.
 - 7) Valley metal, back pans, roof jacks, and roof vent flashing as required by Metal Shingle Manufacturer to meet warranty requirements.
 - 8) Deck slope: Metal shingles shall not be installed on roof slopes below three units vertical in 12 units horizontal (25 percent slope).
 - b. Category Four Approved Products. See Section 01 6200 for definitions of Categories:
 - 1) Perma-Lock by Aluminum Shingle Company.
 - a) Approved colors.
 - (1) Charcoal Grey
 - (2) Dawn Gray
 - (3) Driftwood Cedar
 - (4) Regal Brown
 - (5) Matte Black
 - (6) Mill Finish
 - (7) Terra Cotta Red
 - (8) Classic Green
 - (9) Tudor Brown
 - (10) Premium Colors
 - (11) Custom Colors
3. Secondary Underlayment:
 - a. Description:
 - 1) High-tensile-strength rubberized asphalt underlayment specifically designed to withstand temperatures up to **250 deg F (121 deg C)**.
 - 2) Skid-resistant membrane provides protection from water penetration caused by wind-driven rain and ice dams.
 - 3) Self-adhering roofing underlayment.
 - b. Design Criteria:
 - 1) High temperature resistance.
 - 2) Resists cracking, drying and rotting.
 - 3) Seals around nails and fasteners.
 - 4) Slip resistant surface.
 - 5) ICC-ESR approved.
 - 6) Comply with ASTM D1970/D1970M.
 - 7) UL 790 Class A Fire Resistance.
 - 8) Thickness: **40 mil (1.016 mm)**.
 - 9) Florida Certificate of Product approval.

2. ACCESSORIES

A.Fasteners:

- 1. Design Criteria:
 - a. Ring shank aluminum nail.
 - b. Corrosion resistant nails conforming to ASTM F1667.
 - c. Comply with FBC Section 1506.5, 'Nails'.
- 2. Metal Shingles:
 - a. 9 gauge ring shank **1-1/2 inches (38 mm)** long corrosive resistant aluminum nail.

B.Panel Clips:

- 1. Provided by Metal Shingle Manufacturer:
 - a. Product Model: Two-hole, stainless steel Bermuda clip.
 - b. Part No. BC-2H-22-S.
 - c. Type: One-piece, fixed clip.
 - d. Material: Stainless Steel, Type 304.

- e. Thickness: 22 gauge.
 - f. Dimensions: 2-1/2 inch high x 1-7/8 inch wide x 1/8 inch thick (63.5 mm high x 48 mm wide x 3 mm thick).
 - g. Yield Strength: 40 ksi (276 MPa) minimum.
 - h. Corrosion resistant: conform to ASTM A167, Type 304.
 - i. Corrosion Resistance: In compliance with FBC Section 1506.7, 'Clips'.
- C. Sealant:
- 1. Description:
 - a. Premium-grade, high-performance, moisture-cured, 1-component, polyurethane-based, non-sag elastomeric sealant.
 - b. Design Criteria:
 - 1) Meet following standards for Sealant:
 - a) ASTM C920: Type S Grade NS, Class 35 Use T, NT, O, M, G, I.
 - b) Federal specification TT-S-00230C, Type II, Class A.
 - 2) Maximum depth of sealant will not exceed 1/2 inch (12.7 mm).
 - 3) Suitable for vertical and horizontal joints.
 - 4) Application temperature: 40 deg F (4.4 deg C) to 100 deg F (37.8 deg C).
 - c. Category Four Approved Products. See Section 01 6200 for definitions of Categories:
 - 1) Sikaflex-1a by Sika Sarnafil, Canton, MA www.sikacorp.com.
- D. Snow Guards:
- 1. Description: Brackets attached to metal shingles to control snow and ice sliding off roof.
 - 2. Category Four Approved Manufacture And Products. See Section 01 6200 for definitions of Categories:
 - a. Sieger Snow Guards, Inc. Leesport, PA www.siegersnowguards.com.
 - 1) Model C: aluminum with guard strap concealed fastener.
 - 2) Model MC2: Adhesive mounted aluminum with exposed screws.

3. EXAMINATION

- A. Verification Of Conditions:
- 1. Examine deck to determine if it is satisfactory for installation of roofing system. Conditions include, but are not limited to, moisture on deck, protruding deck fasteners, specified gaps between sheathing, and other items affecting issuance of roofing warranty.
 - 2. Notify Architect of unsuitable conditions in writing.
 - 3. Commencement of Work by installer is considered acceptance of substrate.

4. PREPARATION

A.Surface Preparation:

- 1. Sealant:
 - a. Clean all surfaces. Surfaces must be sound, clean, dry, frost-free, and free of oil and grease. Foreign matter must be thoroughly removed.
 - b. roof sheathing, including removal of dirt and debris, before installation of underlayment.
- 2. Underlayment:
 - a. Clean roof sheathing, including removal of dirt and debris, before installation of underlayment.

5. INSTALLATION

A. General:

- 1. All panels must be installed in accordance with applicable codes and Manufacture's published installation instructions.

B.Interface With Other Work:

- 1. Coordinate with pipe installers for proper size of roof jacks and pipe flashing.
- 2. Coordinate with ridge vent installer for sequencing of

- C. Underlayment:
1. General:
 - a. Do not use permanent underlayment installation as temporary roof. If temporary roof is used, remove completely before installation of permanent underlayment.
 - b. Follow Manufacturer's recommendations for installation of secondary underlayment, particularly at eaves, rakes, and penetrations, unless specified installation procedures and Contract Drawing details are more stringent.
 - c. Install valley secondary underlayment and valley metal after installation of secondary underlayment.
 - d. Severe Climate Areas:
 - 1) In areas where there has been history of ice forming along eaves and causing backup of water, install secondary underlayment in accordance with IBC Section 1507.5.4.
 - e. Valleys:
 - 1) Sweep surface to remove dirt and debris so secondary underlayment will seal to surface.
 - 2) Apply one (1) continuous **36 inch (300 mm)** wide strip of secondary underlayment and centered over valley.
 - 3) Install formed valley metal over strip of secondary underlayment:
 - a) Nail top of each section and lap **8 inches (200 mm)** in direction of flow.
 - b) Seal laps with continuous bead of elastomeric roofing sealant.
 - c) Secure edges of valley metal with fasteners spaced at **6 inches (300 mm)** maximum on center and approximately **1/2 inch (13 mm)** in from edge of metal.
 - 4) Install **12 inches (300 mm)** wide strips of secondary underlayment lapping nailed edge of formed valley metal **3 inches (75 mm)**.
- D. Valleys:
1. Install valley metal lapped **8 inches (203 mm)** from centerline each way and shall have splash diverter rib not less than **3/4 inch (19 mm)** high at flow line formed as part of flashing.
 - a. Sections of flashing shall have end lap of not less than **4 inch (100 mm)**.
 - b. Metal valley flashing shall have **36 inches (900 mm)** wide underlayment directly under it consisting of one (1) layer of underlayment running full length of valley, in addition to underlayment required for metal roof shingles.
 2. Install in accordance with IBC Section 1507.5.7 'Flashing'.
- E. Flashing And Counter Flashings:
1. Install as recommended by Metal Shingle Manufacturer.
- F. Roof Jacks:
1. Install as recommended by Metal Shingle Manufacturer.
 2. Install in accordance with IBC Section 1503.2 'Flashing'.
- G. Roofing:
1. Install metal shingles in accordance with installation manual provided by Metal Shingle Manufacturer.
- H. Ridge, Rake, And Ridge Caps:
1. Install as recommended by Metal Shingle Manufacturer.
- I. Roof Vents:
1. Install as recommended by Metal Shingle Manufacturer
- J. Snow Guards:
1. Install as recommended by Snow Guard Manufacturer.
- K. Sealant:
1. Install and at temperatures recommended by Sealant Manufacturer at locations recommended by Metal Shingle Manufacturer.

6. CLEANING

A. General:

1. All tools and unused materials must be collected at end of each workday and stored properly off finished roof surface and protected from exposure to elements.
2. Leave metals clean and free of defects, stains, and damaged finish.
 - a. Replace fascia metal that is scratched through finish to base metal.
3. Properly clean finished roof surface after completion.
4. Verify drains and gutters are not clogged.
5. Clean shingles and building of soiling caused by this installation.
6. Clean and restore all damaged surfaces to their original condition.

B. Waste Management:

1. Disposal:
 - a. All work areas are to be kept clean, clear and free of debris at all times.
 - b. Do not allow trash, waste, or debris to collect on roof. These items shall be removed from roof on a daily basis.
 - c. Remove debris resulting from work of this Section from roof and site. Dispose of or recycle all trash and excess material in manner conforming to current EPA regulations and local laws.

END OF SECTION