

*Commonwealth of Massachusetts  
Alcoholic Beverages Control Commission  
95 Fourth Street, Suite 3  
Chelsea, Massachusetts 02150*

**Jean M. Lorizio, Esq.**  
Chair

NOTICE OF SUSPENSION

March 28, 2024

**TRIPLE F PUB INC. D/B/A THE PUB  
682-686 BROADWAY  
SOMERVILLE, MA 02155  
LICENSE#: 00015-RS-1130  
VIOLATION DATE: 4/11/2023  
HEARD: 9/26/2023**

After a hearing on September 26, 2023, the Commission finds Triple F Pub Inc. d/b/a The Pub violated 204 CMR 2.05 (2) Permitting an illegality on the licensed premises, to wit: Ch. 138, § 34C – Possession of an alcoholic beverage by a person under 21 years of age (11 Counts). The Commission **suspends the license for a period of five (5) days to be served.**

**The suspension shall commence on Monday, May 13, 2024, and terminate on Friday, May 17, 2024.** The license will be delivered to the Local Licensing Board or its designee on Monday, May 13, 2024, at 9:00 A.M. It will be returned to the licensee on May 18, 2024.

You are advised that pursuant to the provisions of M.G.L. c.138 § 23, you may petition the Commission to accept an offer in compromise in lieu of suspension within twenty (20) calendar days following such notice of such suspension. If accepted, you may pay a fine using the enclosed form which must be signed by the Licensee and a Massachusetts Licensed Accountant.

You are advised that you have the right to appeal this decision under M.G.L. c. 30A to Superior Court within thirty (30) days upon receipt of this notice.

**ALCOHOLIC BEVERAGES CONTROL COMMISSION**

Jean M. Lorizio  
Chairman

This document is important and should be translated immediately.  
Este documento es importante y debe ser traducido inmediatamente.  
Este documento é importante e deve ser traduzido imediatamente.  
Ce document est important et devrait être traduit immédiatement.  
Questo documento è importante e dovrebbe essere tradotto immediatamente.  
Το έγγραφο αυτό είναι σημαντικό και θα πρέπει να μεταφραστούν αμέσως.  
这份文件是重要的，应立即进行翻译。  
यह दस्तावेज़ महत्वपूर्ण है और इसका तुरंत अनुवाद किया जाना चाहिए  
Dokiman sa a enpòtan epi li ta dwe tradwi touswit  
'Đây là tài liệu quan trọng và cần được dịch ngay'  
ឯកសារនេះសំខាន់ណាស់ ហើយត្រូវបកប្រែជាបន្ទាន់។

cc: Local Licensing Board  
Frederick G. Mahony, Chief Investigator  
John David, Investigator  
Christopher Temple, Investigator  
Administration, File

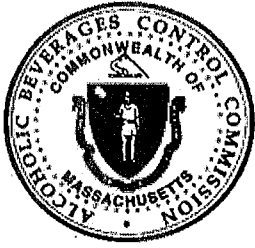

*Commonwealth of Massachusetts  
Alcoholic Beverages Control Commission  
95 Fourth Street, Suite 3  
Chelsea, Massachusetts 02150*

**Jean M. Lorizio, Esq.**  
Chair

**DECISION**

**TRIPLE F PUB INC. D/B/A THE PUB  
682-686 BROADWAY  
SOMERVILLE, MA 02155  
LICENSE#: 00015-RS-1130  
VIOLATION DATE: 4/11/2023  
HEARD: 9/26/2023**

Triple F Pub Inc. d/b/a The Pub (“Licensee”) holds an alcohol license issued pursuant to M.G.L. c. 138, § 12. The Alcoholic Beverages Control Commission (“ABCC” or “Commission”) held a remote hearing via Microsoft Teams on Tuesday, September 26, 2023, regarding alleged violations of 204 CMR 2.05 (2) Permitting an illegality on the licensed premises, to wit: Ch. 138, § 34C – Possession of an alcoholic beverage by a person under 21 years of age (11 Counts). Prior to the commencement of the hearing, the Licensee stipulated to the facts alleged in Investigator David’s report.

The following documents are in evidence:

1. Investigator David’s Report;
2. ABCC Form 43 License, Transfer of License Approval, 9/22/2008;
3. Photographs of Fraudulent Driver’s Licenses Confiscated;
4. Licensee’s Stipulation of Facts.

There is one (1) audio recording of this hearing.

**FINDINGS OF FACT**

1. On Tuesday April 11, 2023, at approximately 10:15 p.m., Investigators Temple and David (“Investigators”), inspected Triple F Pub Inc. d/b/a The Pub (“Licensee”) to determine the way its business was being conducted.
2. Investigators entered the licensed premises and observed a table, in the back left area of the establishment, with four youthful appearing individuals in possession of what appeared to be alcoholic beverages. Investigators approached, identified themselves and requested proof of legal age to possess alcoholic beverages.

3. Underage #1, actual date of birth [REDACTED], was in possession of a cranberry vodka mixed drink. She presented to Investigators a fraudulent Maine driver's license bearing her name but a different birth date.
4. Underage #2, actual date of birth [REDACTED], was in possession of a cranberry vodka mixed drink. She presented to Investigators a fraudulent Tennessee driver's license bearing her name but a different birth date.
5. Underage #3, actual date of birth [REDACTED], was in possession of a Fiddlehead beer. He informed Investigators that he was not asked for any identification when he entered the premises.
6. Underage #4, actual date of birth [REDACTED], was in possession of a Fiddlehead beer. He informed Investigators that he was not asked for any identification when he entered the premises.
7. Investigators observed a table with five youthful appearing individuals in possession of what appeared to be alcoholic beverages. Investigators approached, identified themselves and requested proof of legal age to possess alcoholic beverages.
8. Underage #5, actual date of birth [REDACTED], was in possession of a Bud Light draft beer. He presented to Investigators a fraudulent New Jersey driver's license bearing his name but a different birth date.
9. Underage #6, actual date of birth [REDACTED] was in possession of a Bud Light draft beer. He presented to Investigators a fraudulent Delaware driver's license bearing his name but a different birth date.
10. Underage #7, actual date of birth [REDACTED], was in possession of a Bud Light draft beer. He presented to Investigators a fraudulent Pennsylvania driver's license bearing his name but a different birth date.
11. Underage #8, actual date of birth [REDACTED], was in possession of a Bud Light draft beer. He presented to Investigators a fraudulent New Jersey driver's license bearing his name but a different birth date.
12. Underage #9, actual date of birth [REDACTED] was in possession of a Bud Light draft beer. He presented to Investigators a fraudulent New Jersey driver's license bearing his name but a different birth date.
13. Investigators observed two individuals exiting the premises who were still in possession of alcoholic beverages. Investigators identified themselves and requested proof of legal age.
14. Underage #10, actual date of birth [REDACTED], was in possession of a Sam Adams beer. He presented to Investigators a fraudulent Connecticut driver's license bearing his name but a different birth date.
15. Underage #11, actual date of birth [REDACTED], was in possession of a Sam Adams beer. He presented to Investigators a fraudulent Georgia driver's license bearing his name but a different birth date.

16. Investigators identified the underage individuals to the staff and the bartender and showed them the fraudulent identifications which had been confiscated.
17. Investigators informed the bartender of the violations and that a report would be filed with the Chief Investigator for further action.
18. Francis Healy, Licensee, appeared at the Commission hearing and testified regarding his efforts to prevent minors from obtaining alcohol. He stated there are 3 employees posted at the door and they are instructed to request identification from all patrons. Mr. Healy stated all identifications are now scanned. He acknowledged his establishment is near a college and instituted a policy wherein any patron presenting an out-of-state identification must produce a backup identification, such as a credit card, or they will not be served. He added that a school identification is not accepted as back-up.
19. The Licensee has held a license under M.G.L. c. 138, § 12 since 2008, approximately 15 years, with no prior violations.

CONCLUSION

Based on the evidence, the Commission finds the Licensee violated 204 CMR 2.05 (2) Permitting an illegality on the licensed premises, to wit: Ch. 138, § 34C – Possession of an alcoholic beverage by a person under 21 years of age (11 Counts).

Therefore, the Commission **suspends the license for a period of 15 days of which five (5) days will be served and ten (10) days will be held in abeyance for a period of two (2) years provided no further violations of Chapter 138 or Commission regulations are found by this Commission.**

**ALCOHOLIC BEVERAGES CONTROL COMMISSION**

Jean M. Lorizio, Chairman \_\_\_\_\_

*Jean M. Lorizio*

Crystal Matthews, Commissioner \_\_\_\_\_

*Crystal Matthews*

Deborah Baglio, Commissioner \_\_\_\_\_

*Deborah A. Baglio*

Dated: March 28, 2024

You have the right to appeal this decision to the Superior Courts under the provisions of Chapter 30A of the Massachusetts General Laws within thirty (30) days of receipt of this decision.

This document is important and should be translated immediately.  
Este documento es importante y debe ser traducido inmediatamente.  
Este documento é importante e deve ser traduzido imediatamente.  
Ce document est important et devrait être traduit immédiatement.  
Questo documento è importante e dovrebbe essere tradotto immediatamente.  
Το έγγραφο αυτό είναι σημαντικό και θα πρέπει να μεταφραστούν αμέσως.  
这份文件是重要的，应立即进行翻译。  
यह दस्तावेज़ महत्वपूर्ण है और इसका तुरंत अनुवाद किया जाना चाहिए  
Dokiman sa a enpòtan epi li ta dwe tradwi touswit  
'Đây là tài liệu quan trọng và cần được dịch ngay'  
ឯកសារនេះសំខាន់ណាស់ ហើយត្រូវបកប្រែជាបន្ទាន់។

2023-000169-ad-enf

cc: Local Licensing Board  
Frederick G. Mahony, Chief Investigator  
John David, Investigator  
Christopher Temple, Investigator  
Administration, File

# PUBLIC EVENT/SPECIAL ALCOHOL LICENSE APPLICATION

City of Somerville, Commonwealth of Massachusetts

Application #: PEL24-000038

File #: 15-008961

**Application for:** Special Alcohol, All Forms

**Organization name:** St. Anthony Parish

**Description:** This is Saint John's Feast organized by the Brazilian community of our Church

**Date(s):** June 22, 2024

**Setup starts at (time):** 10am

**Cleanup after the event ends at (time):** 1am

**Entertainment:** Food, dance, music.

**Attendees:**

Max attendance at one time: 700

Maximum attendees accommodated: 700

**Attendee fees or suggested donations:** N/A

**Social or cultural benefits:**

N/A

**Event Contact:** [REDACTED] Rev Lino Garcia

**Alcohol service begins at:** 5pm

**Event name:** FESTA JUNINA 2024

**Location:** 12 Properzi Way, Somerville MA 02143  
Parking lot of the church

**Rain date(s):** N/A (at this time)

**Event starts at (time):** 5pm

**Event ends at (time):** 11:30pm

**Temporary Structures:** Inflatables for kids and tents

Total people attending: 700

Total Somerville residents attending: Open to the public

**What is your budget for this event:** \$1300

**Financial benefits:**

N/A

**Event Contact Phone:** [REDACTED]

**Alcohol service ends at:** 11:30pm

---

Event Information	Yes/No	If yes, Describe
Open to the public?	Yes	Open party for food tasting and dancing
Food served?	Yes	Brazilian traditional food
Caterer used?	No	
Alcohol served?	Yes	Alcohol to be served: All Forms, Outdoors In one of the Saint Anthony's parking lot
Grill/open-flame device used?	Yes	We will have a grill for the people in charge to cook traditional Brazilian food
Streets blocked?	No	
Sidewalks blocked?	No	
Describe any accessibility features available to attendees/participants		N/A
<b>Arrangements:</b>		
Police Detail:	Yes	2 Police Detail
Parking (for Attendees)?	Yes	Saint Anthony of Padua Parish parking lot
Restrooms?	Yes	Saint Anthony of Padua Church's restrooms
Liability Insurance?	Yes	Archdiocese of Boston Insurance
Will any public parks be used?	No	
Has the event occurred in the last two years?	Yes	FESTA JUNINA 2022 AND FESTA JUNINA 2023

---

# PUBLIC EVENT/SPECIAL ALCOHOL LICENSE APPLICATION

City of Somerville, Commonwealth of Massachusetts

Application #: PEL24-000030

File #: 23-020485

**Application for:** Special Alcohol, Wine and Malt

**Organization name:** Downeast Cider

**Description:** One 10 foot converted shipping container opens up to match VOLO league times at The Park. Earliest we will be open is noon. The latest we will be open is 10:00 PM with a hard cut off last call at 9:30 PM.

**Date(s):** 5/1/2024 - 5/30/2024

**Setup starts at (time):** 11:00 AM (earliest)

**Cleanup after the event ends at (time):** 10:30 PM (latest)

**Entertainment:** VOLO league games + VOLO pick up game days as well as performances on the Lawn.

## Attendees:

Max attendance at one time: 175

Maximum attendees accommodated: 250

**Attendee fees or suggested donations:** N/A

## Social or cultural benefits:

Helping to, along with VOLO, activate an otherwise vacant outdoor space that can be enjoyed by the Somerville community and everyone who visits. Driving traffic to the many events held on the Lawn (i.e. Salsa dancing on Fridays!)

**Event Contact:** Roisin Gilligan

**Alcohol service begins at:** 12:00 PM (earliest)

**Event name:** Downeast @ the Park by VOLO

**Location:** VOLO area @ The Park in Assembly Row

**Rain date(s):** N/A

**Event starts at (time):** 12:00 PM (earliest)

**Event ends at (time):** 10:00 PM (latest)

**Temporary Structures:** (2) 10 foot shipping containers; one of which houses our bar service area and the other for back up supplies + storage. (Both contained within 'The Park').

Total people attending: 2-3k (total over month)

Total Somerville residents attending: 50+ daily

**What is your budget for this event:** \$50k

## Financial benefits:

Driving traffic to the Assembly Row retail stores and restaurants.

**Event Contact Phone:** [REDACTED]

**Alcohol service ends at:** 9:30 PM (latest)

Event Information	Yes/No	If yes, Describe
Open to the public?	Yes	110k+ followers across social media platforms + email marketing
Food served?	No	
Caterer used?		
Alcohol served?	Yes	Alcohol to be served: Wine and Malt, Outdoors One ten foot shipping container within the fenced in VOLO area @ The Park in Assembly Row. TIPS certified staff will be selling draft and can pours of hard cider and malt base beverages.
Grill/open-flame device used?	No	
Streets blocked?	No	
Sidewalks blocked?	No	
Describe any accessibility features available to attendees/participants		N/A

## Arrangements:



Police Detail:	No	
Parking (for Attendees)?	No	
Restrooms?	Yes	Porto Potty's provided by VOLO
Liability Insurance?	Yes	provided by VOLO
Will any public parks be used?	No	
Has the event occurred in the last two years?	Yes	July 2023 - November 2023.

---

**Approval Conditions:**

**Reviewer:** Darrell Richardson, Fire Prevention, Approved with Conditions

1. A tent permit is required from Fire Prevention for the larger tent (any tent over 10'x12' requires a permit). If you are cooking with propane, a flammable permit from Fire Prevention is needed if there will be more than 42 pounds of propane on-site. Food trucks require a Food Truck permit form Fire Prevention. Any open flame must be at least 20 feet from any tent. Please see the Somerville Fire Prevention website for permitting and detail information: <https://www.somervillema.gov/fireprevention>

# LICENSING COMMISSION LICENSE APPLICATION

City of Somerville, Commonwealth of Massachusetts

Application #: SFW24-000001

File #: 23-004312

**Business Name:** Blisspoint Meadery

**Application Type:** Special Farmer Winery (agricultural events)

**Location:** 66-70 Union Square (Union Square)

---

## APPLICANT

**Company Name:** Blisspoint Meadery

**Business Address:**

1 Fox Run Rd.

Bedford, MA 01730

**Manager of Establishment:** Jeff Venuti

**Manager Email:** [REDACTED]

**Manager Phone Number:** [REDACTED]

**Approval Conditions**

---

## BUSINESS INFORMATION

**Legal Name of the Proposed Licenseholder (Name of Corporation, LLC, Partnership/LLP, Trust, Sole Proprietor, Other)**

Blisspoint LLC

**DBA Name**

Blisspoint Meadery

**In the last 3 years, have you admitted liability or been found liable under any state or federal law regulating the payment of wages to employees, or the collection of debt from employees?**

**In the last 5 years, have you been found guilty, liable, or responsible, in any judicial or administrative proceeding, for any violation of the City Wage Theft Ordinance or any State or Federal laws or regulations regulating the payment of wages?** [City Wage Theft Ordinance](..../Documents/149/WAGE%20THEFT%20ORDINANCE.pdf target=_blank)

No

**Explain**

**Manager of your establishment**

Jeff Venuti

**Manager email**

[REDACTED]

**Manager phone**

[REDACTED]

---

## OPERATING INFORMATION

**Name of agricultural event (each event must be applied for separately)**

Union Square Farmers Market

**Location of agricultural event**

66-70 Union Square (Union Square)

**Date(s) and time(s)**

Saturdays, 5/11/2024 to 10/26/2024 9:00am to 1:00pm

**What are you selling and/or sampling?**

Mead, alcohol made with honey. Regulated the same as wine.

Estimated attendance at any one time	1000
Estimated total attendance	10000
Have you ever obtained a Special Farmer Winery License before?	Yes
Describe	Davis Square Farmers Market (2022) Union Square Farmers Market (2023) Somerville Winter Farmers Market (2023)
Have you ever had a Special Farmer Winery License denied, suspended, or revoked?	No
Describe	
Have you ever received a Notice of Violation?	No
Describe	

---

**<font size=3><i class=icon-check></i> TERMS AND CONDITIONS**

**ACKNOWLEDGEMENT, RELEASE AND INDEMNIFICATION, AND WAGE THEFT ORDINANCE RECEIPT**

By clicking submit below, I certify that I am the Applicant or that I am duly authorized to act as an agent for the Applicant

I certify that all information provided on this application is true and accurate, and I acknowledge that any information found to be false or misleading will result in the forfeiture of this license and may result in a one-year wait before a new application can be submitted, as well as criminal prosecution.

I certify that the Applicant will make no changes to any component of the business plan described in this application without written notification to, and the prior approval of, the City.

I certify that the Applicant will adhere to any and all City ordinances, regulations, and conditions pertaining to this license, and I acknowledge that any violation of City ordinances, regulations, and conditions pertaining to this license could subject the Applicant and anyone operating under this license to arrest, fine, and loss of this license.

I acknowledge that the so-called Wage Theft Ordinance, part of the Municipal Ordinances, has been made available to me as part of this application process.

I certify that the applicant, to my best knowledge and belief, has filed all State tax returns and paid all State taxes required under law.

I release, discharge and hold harmless, the City of Somerville, a municipal corporation of the Commonwealth of Massachusetts, and its officers, employees, agents and servants from all actions, causes of action, claims,

**demands, damages, costs, loss of services, expenses and compensation associated with the issuance of this license, and the conduct of anyone operating under this license.**

**You must read and accept the above stated terms & conditions**

Yes

# LICENSING COMMISSION LICENSE APPLICATION

City of Somerville, Commonwealth of Massachusetts

Application #: SFW24-000002

File #: 22-017271

**Business Name:** Blisspoint Meadery

**Application Type:** Special Farmer Winery (agricultural events)

**Location:** municipal parking lot adjacent to the Davis Square Plaza

---

## APPLICANT

**Company Name:** Blisspoint Meadery

**Business Address:**

1 Fox Run Rd.

Bedford, MA 01730

**Manager of Establishment:** Jeff Venuti

**Manager Email:** [REDACTED]

**Manager Phone Number:** [REDACTED]

**Approval Conditions**

---

## BUSINESS INFORMATION

**Legal Name of the Proposed Licenseholder (Name of Corporation, LLC, Partnership/LLP, Trust, Sole Proprietor, Other)**

Blisspoint LLC

**DBA Name**

Blisspoint Meadery

**In the last 3 years, have you admitted liability or been found liable under any state or federal law regulating the payment of wages to employees, or the collection of debt from employees?**

**In the last 5 years, have you been found guilty, liable, or responsible, in any judicial or administrative proceeding, for any violation of the City Wage Theft Ordinance or any State or Federal laws or regulations regulating the payment of wages?**

No

[href=..\Documents\149\WAGE%20THEFT%20ORDINANCE.pdf](..\Documents\149\WAGE%20THEFT%20ORDINANCE.pdf)  
[target=\\_blank>City Wage Theft Ordinance</a>](#)

**Explain**

**Manager of your establishment**

Jeff Venuti

**Manager email**

[REDACTED]

**Manager phone**

[REDACTED]

---

## OPERATING INFORMATION

**Name of agricultural event (each event must be applied for separately)**

Davis Square Farmers Market

**Location of agricultural event**

municipal parking lot adjacent to the Davis Square Plaza

**Date(s) and time(s)**

Wednesdays, 5/22/2024 through 11/27/2024, 12pm to 6pm

**What are you selling and/or sampling?**

Mead, an alcohol made from honey, regulated same as wine

Estimated attendance at any one time	1000
Estimated total attendance	10000
Have you ever obtained a Special Farmer Winery License before?	Yes
Describe	Somerville Davis Square Farmers Market Somerville Union Square Farmers Market Somerville Winter Farmers Market
Have you ever had a Special Farmer Winery License denied, suspended, or revoked?	No
Describe	
Have you ever received a Notice of Violation?	No
Describe	

---

**<font size=3><i class=icon-check></i> TERMS AND CONDITIONS**

**ACKNOWLEDGEMENT, RELEASE AND INDEMNIFICATION, AND WAGE THEFT ORDINANCE RECEIPT**

By clicking submit below, I certify that I am the Applicant or that I am duly authorized to act as an agent for the Applicant

I certify that all information provided on this application is true and accurate, and I acknowledge that any information found to be false or misleading will result in the forfeiture of this license and may result in a one-year wait before a new application can be submitted, as well as criminal prosecution.

I certify that the Applicant will make no changes to any component of the business plan described in this application without written notification to, and the prior approval of, the City.

I certify that the Applicant will adhere to any and all City ordinances, regulations, and conditions pertaining to this license, and I acknowledge that any violation of City ordinances, regulations, and conditions pertaining to this license could subject the Applicant and anyone operating under this license to arrest, fine, and loss of this license.

I acknowledge that the so-called Wage Theft Ordinance, part of the Municipal Ordinances, has been made available to me as part of this application process.

I certify that the applicant, to my best knowledge and belief, has filed all State tax returns and paid all State taxes required under law.

I release, discharge and hold harmless, the City of Somerville, a municipal corporation of the Commonwealth of Massachusetts, and its officers, employees, agents and servants from all actions, causes of action, claims, demands, damages, costs, loss of services, expenses and compensation associated with the issuance of this license, and the conduct of anyone operating under this license.

You must read and accept the above stated terms & conditions Yes

# LICENSING COMMISSION LICENSE APPLICATION

City of Somerville, Commonwealth of Massachusetts

Application #: SFW24-000003

File #: 24-006423

**Business Name:** Far From the Tree LLC

**Application Type:** Special Farmer Winery (agricultural events)

**Location:** 66-70 Union Square

---

## APPLICANT

**Company Name:** Far From the Tree LLC

**Business Address:**

108 Jackson St  
Salem, MA 01970

**Manager of Establishment:** Roy Szolwinski

**Manager Email:** [REDACTED]

**Manager Phone Number:** [REDACTED]

**Approval Conditions**

---

## BUSINESS INFORMATION

**Legal Name of the Proposed Licenseholder (Name of Corporation, LLC, Partnership/LLP, Trust, Sole Proprietor, Other)**

Far From the Tree LLC

**DBA Name**

Far From the Tree

**In the last 3 years, have you admitted liability or been found liable under any state or federal law regulating the payment of wages to employees, or the collection of debt from employees?**

**In the last 5 years, have you been found guilty, liable, or responsible, in any judicial or administrative proceeding, for any violation of the City Wage Theft Ordinance or any State or Federal laws or regulations regulating the payment of wages?**  
<http://www.cityofsomerville.com/Documents/149/WAGE%20THEFT%20ORDINANCE.pdf>  
**target=\_blank>City Wage Theft Ordinance</a>**

No

**Explain**

**Manager of your establishment**

Roy Szolwinski

**Manager email**

[REDACTED]

**Manager phone**

[REDACTED]

---

## OPERATING INFORMATION

**Name of agricultural event (each event must be applied for separately)**

Union Square Farmers Market

**Location of agricultural event**

66-70 Union Square, Somerville, MA 02143

**Date(s) and time(s)**

Saturdays 5/11/2024-10/26/2024, 9am-1pm

**What are you selling and/or sampling?**

Selling and sampling

**Estimated attendance at any one time**

125

**Estimated total attendance**

2000

Have you ever obtained a Special Farmer Winery License before? Yes

Describe We are licensed in Salem, MA since 2013, and have obtained permits / licenses for various farmers markets during the summers.

Have you ever had a Special Farmer Winery License denied, suspended, or revoked? No

Describe

Have you ever received a Notice of Violation? No

Describe

**TERMS AND CONDITIONS**

**ACKNOWLEDGEMENT, RELEASE AND INDEMNIFICATION, AND WAGE THEFT ORDINANCE RECEIPT**

By clicking submit below, I certify that I am the Applicant or that I am duly authorized to act as an agent for the Applicant

I certify that all information provided on this application is true and accurate, and I acknowledge that any information found to be false or misleading will result in the forfeiture of this license and may result in a one-year wait before a new application can be submitted, as well as criminal prosecution.

I certify that the Applicant will make no changes to any component of the business plan described in this application without written notification to, and the prior approval of, the City.

I certify that the Applicant will adhere to any and all City ordinances, regulations, and conditions pertaining to this license, and I acknowledge that any violation of City ordinances, regulations, and conditions pertaining to this license could subject the Applicant and anyone operating under this license to arrest, fine, and loss of this license.

I acknowledge that the so-called Wage Theft Ordinance, part of the Municipal Ordinances, has been made available to me as part of this application process.

I certify that the applicant, to my best knowledge and belief, has filed all State tax returns and paid all State taxes required under law.

I release, discharge and hold harmless, the City of Somerville, a municipal corporation of the Commonwealth of Massachusetts, and its officers, employees, agents and servants from all actions, causes of action, claims, demands, damages, costs, loss of services, expenses and compensation associated with the issuance of this license, and the conduct of anyone operating under this license.

You must read and accept the above stated terms & conditions Yes



**LICENSING COMMISSION LICENSE APPLICATION**

City of Somerville, Commonwealth of Massachusetts

Application #: MEA24-000002

File #: 24-006422

**Business Name:** Union Leaf, Inc

**Application Type:** Amending a Marijuana Establishment License

**Location:** 71 UNION SQ

---

**APPLICANT**

**Company Name:** Law Office of Walter J. Sullivan, Jr.

**Business Address:**

[REDACTED]  
[REDACTED]

<b>Enter your current business license #</b>	ME19000008
<b>Are you applying to move to a new location?</b>	No
<b>Are you amending an existing license?</b>	Yes
<b>ARE YOU CHANGING OWNERSHIP?</b>	No
<b>ARE YOU CHANGING OFFICERS OR DIRECTORS?</b>	No
<b>ARE YOU CHANGING CONTROL PERCENTAGES?</b>	No
<b>ARE YOU CHANGING THE NAME OF YOUR BUSINESS?</b>	No
<b>ARE YOU CHANGING YOUR HOURS?</b>	Yes
<b>List Current Hours</b>	By appointment only for the first six months of operation
<b>List Proposed New Hours</b>	Mon-Sat:10am-8pm, Sun:10am-5pm

# LICENSING COMMISSION LICENSE APPLICATION

City of Somerville, Commonwealth of Massachusetts

Application #: ALM24-000017

File #: 17-012652

**Business Name:** Terranova Inc

**Amendment Type:** Altering Premises or Outdoor Seating

**Location:** 8 DAVIS SQ

---

## APPLICANT

**Company Name:** TERRANOVA, INC.

**Business Address:**

9 DAVIS SQUARE

SOMERVILLE, MA 02144

**Enter your current business license #** AL17-000029

**Do you currently serve alcohol?** Yes

**ARE YOU CHANGING THE NAME OF YOUR BUSINESS?** No

**ARE YOU CHANGING YOUR MANAGER?** No

**ARE YOU TRANSFERRING/ISSUING/PLEDGING STOCK, OR  
ARE YOU CHANGING DIRECTORS/OFFICERS/PARTNERS  
/TRUSTEES?** No

**ARE YOU ALTERING YOUR EXISTING PREMISES OR  
OUTDOOR SEATING? SELECT YES TO INLCUDE OUTDOOR  
SEATING FOR LICENSE** Yes

**Are you changing your indoor premises?** Yes

**Do you offer seating for the consumption of food on  
premises? (Food includes non-alcoholic beverages)** Yes

**Proposed number of floors on the premises** 2

**Proposed name of floor (Basement, balcony, Main, 2nd floor,  
etc.)1** Main

**Proposed number of rooms1** 2

**Proposed square footage1** 2000

**Number of seats (enter 0 if you do not serve food on  
premises)1** 74

**Proposed name of floor (Basement, balcony, Main, 2nd floor,  
etc.)2** basement

**Proposed number of rooms2** 2

**Proposed square footage2** 1000

**Number of seats (enter 0 if you do not serve food on  
premises)2** 0

**Current Number of Floors Indoors** 2

**Current number of rooms indoors** 2

Current number of seats indoors (enter 0 if you do not serve food on premises)	90
Current total occupancy indoors	90
Proposed number of entrances into the indoor premises	1
Current number of entrances into the indoor premises	1
Proposed number of exits from the indoor premises	2
Current number of exits from the indoor premises	2
Are you changing your outdoor premises?	Yes
Sidewalk	Yes
Proposed number of seats outdoors on sidewalk	16
Proposed number of tables on sidewalk	8
Proposed square footage on sidewalk	398
Proposed number of seats on parklet	19
Are you adding any tents larger than 10 feet by 12 feet?	No
Are you adding igloos or dome like structures?	No
Are you adding, removing, or changing the location of any barriers or perimeters around the outdoor seating?	No
Are you adding any heating elements?	No
Describe any changes in your proposed food services (i.e. table service, counter service, cafeteria, packaged foods only, etc.)	none
Will you have a designated dog area?	Yes
Do you operate an inn?	No
Describe your outreach to the Ward Alderman and neighborhood	email
ARE YOU ADDING, OR ENDING, THE SERVICE OF CORDIALS AND LIQUEURS?	No
ARE YOU CHANGING YOUR HOURS OF OPERATION?	No
ARE YOU CHANGING YOUR ENTERTAINMENT?	No
Total Devices indoors	0
Total Devices Outdoors	0.0
Have you ever received a Notice of Violation?	No
almln the last 5 years, have you been found guilty, liable, or responsible, in any judicial or administrative proceeding, for any violation of the City Wage Theft Ordinance or any State or Federal laws or regulations regulating the payment of wages?  <a href=../Documents/149/WAGE%20THEFT%20ORDINANCE.pdf target=NEW>City Wage Theft Ordinance</a>	No
You must read and accept the above stated terms & conditions	Yes
You must read and accept the above stated terms &	Yes

**conditions**

**Approved By:**

**Albert Bargoote, Approved**

**Darrell Richardson, Approved**

**Andrea Como, Approved with Conditions**

When your outdoor dining area is completely setup call ISD Health for a safety inspection. 617-625-6600 ext. 4331

**Andrea Torres, Approved**

**Niki Green, Approved with Conditions**

COMPLETE: NG240322 Please confirm this application is only for sidewalk seating using the plan uploaded 03/14/2024. Parklet seating is not currently included in this application.

RECORD COMMENT: NG240322 This application includes a liquor license and non-contiguous premises that require ABCC approval before implementation.

COMPLETE: NG240322 Provide at least one accessible table or 10% of total outdoor seating in each license area, whichever is greater. Accessible tables shall be distributed by size and location throughout the license area (521 CMR 17.2). Revise plan to show minimum clear width of 36" in path between accessible entrance and accessible table. (521 CMR 20.0)

COMPLETE: NG240322 Post a conspicuous sign to designate the outdoor dog area. Show on plan.

APPROVAL CONDITION IMM 240326: A 60" accessible clear path width between the outdoor seating railing and edge of concrete panels must be maintained at all times. This may be reduced to 48" clear path at pinch points.

Engineering Approval  
with Conditions  
Isabela Maia  
03/26/2024

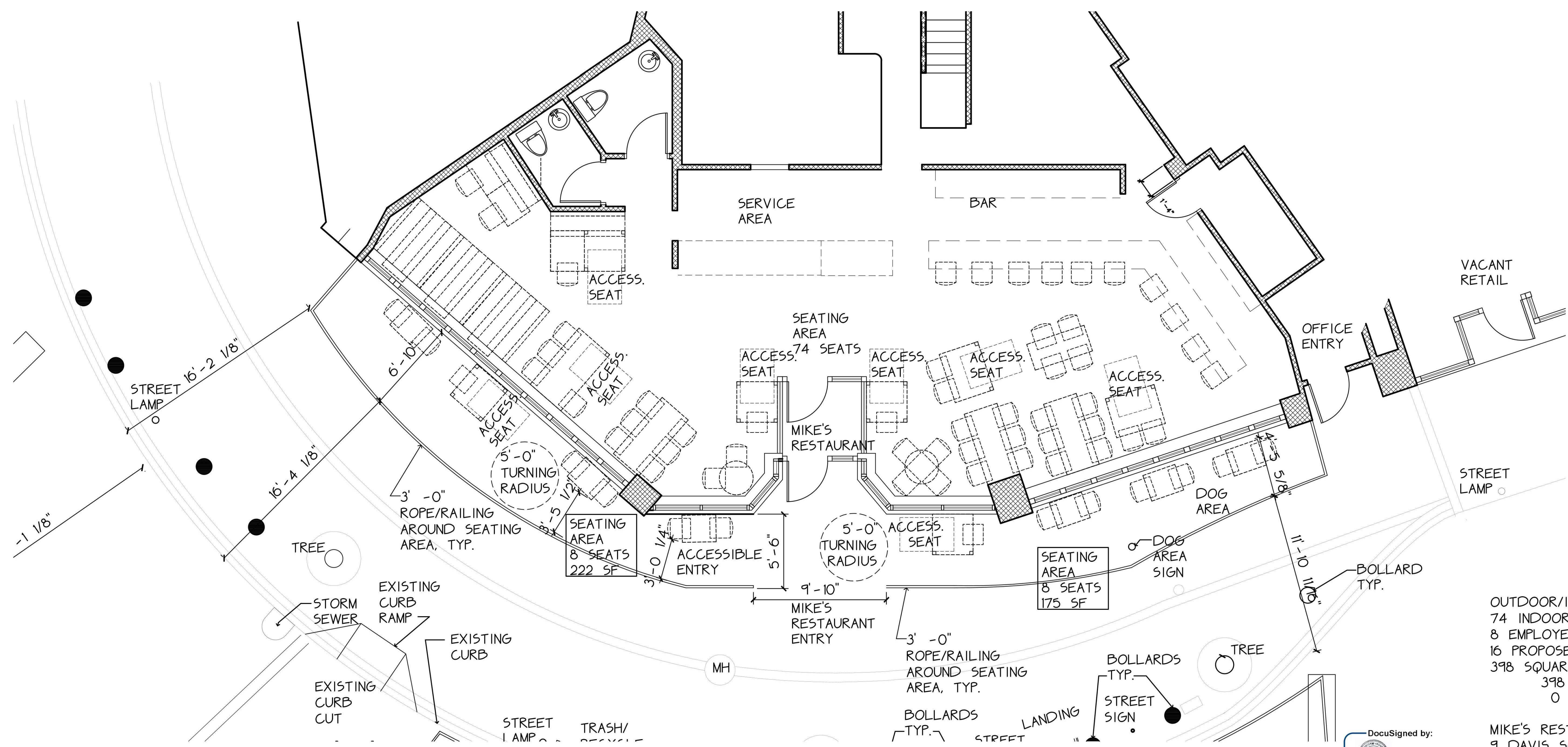

OUTDOOR/INDOOR SEATING PLAN  
 74 INDOOR SEATS  
 8 EMPLOYEES  
 16 PROPOSED OUTDOOR SEATS  
 398 SQUARE FEET  
 398 SIDEWALK  
 0 PARKLET

MIKE'S RESTAURANT  
 9 DAVIS SQUARE  
 SOMERVILLE, MA  
 SCALE: 1/8"=1'-0"  
 MARCH 22, 2024

DocuSigned by:  
  
 FE43A8AA8F814DE...  
 Cindy Larson MA Arch Lic 9899

# LICENSING COMMISSION LICENSE APPLICATION

City of Somerville, Commonwealth of Massachusetts

Application #: ALM24-000018

File #: 23-007639

**Business Name:** pinky swear inc dba june bug

**Amendment Type:** Altering Premises or Outdoor Seating

**Location:** 251-251A WASHINGTON ST

---

## APPLICANT

**Company Name:** Pinky Swear INC

**Business Address:**

5 Mountain Ave

Somerville, MA 02143

**Enter your current business license #** AL23-000018

**Do you currently serve alcohol?** Yes

**ARE YOU CHANGING THE NAME OF YOUR BUSINESS?** No

**ARE YOU CHANGING YOUR MANAGER?** No

**ARE YOU TRANSFERRING/ISSUING/PLEDGING STOCK, OR  
ARE YOU CHANGING DIRECTORS/OFFICERS/PARTNERS  
/TRUSTEES?** No

**ARE YOU ALTERING YOUR EXISTING PREMISES OR  
OUTDOOR SEATING? SELECT YES TO INLCUDE OUTDOOR  
SEATING FOR LICENSE** Yes

**Are you changing your indoor premises?** No

**Are you changing your outdoor premises?** Yes

**Parklet** Yes

**Proposed number of seats on parklet** 18

**Proposed number of tables on parklet** 9

**Proposed square footage of parklet** 272sqft

**Are you adding any tents larger than 10 feet by 12 feet?** No

**Are you adding igloos or dome like structures?** No

**Are you adding, removing, or changing the location of any  
barriers or perimeters around the outdoor seating?** On public property

**Are you adding any heating elements?** No

**Will you have a designated dog area?** No

**Do you operate an inn?** No

**Describe your outreach to the Ward Alderman and  
neighborhood** We reached out and received approval from Alderman Ben Ewen-  
Campen as well as neighboring businesses.

**ARE YOU ADDING, OR ENDING, THE SERVICE OF  
CORDIALS AND LIQUEURS?** No

**ARE YOU CHANGING YOUR HOURS OF OPERATION?** No

<b>ARE YOU CHANGING YOUR ENTERTAINMENT?</b>	No
<b>Total Devices indoors</b>	0
<b>Total Devices Outdoors</b>	0.0
<b>Have you ever received a Notice of Violation?</b>	No
<b>alIn the last 5 years, have you been found guilty, liable, or responsible, in any judicial or administrative proceeding, for any violation of the City Wage Theft Ordinance or any State or Federal laws or regulations regulating the payment of wages?</b>	No
<a href="http://www.cityofsomerville.com/Documents/149/WAGE%20THEFT%20ORDINANCE.pdf">http://www.cityofsomerville.com/Documents/149/WAGE%20THEFT%20ORDINANCE.pdf</a>	
<b>You must read and accept the above stated terms &amp; conditions</b>	Yes
<b>You must read and accept the above stated terms &amp; conditions</b>	Yes

**Approved By:**

- Albert Bargoot, Approved**
- Darrell Richardson, Approved**
- CS Traffic and Parking, Approved**
- Andrea Como, Approved with Conditions**

When your out door seating is completely set up , please contact ISD health Division to schedule a safety inspection at 617-625-6600 ext. 4331

- Andrea Torres, Approved**
- Niki Green, Approved with Conditions**

N/A IMM 240327: Applicant proposing platform. // NG 240312 Parklet Seating that remains at roadway grade (typically 6" below sidewalk grade) shall include an accessible ramp with a 1:12 (8.3%) maximum slope, 48" clear width, 60" by 60" level landings on both ends, and handrails (521 CMR 24) and/or an accessible curb cut in good repair at an existing crosswalk (521 CMR 21); and application shall include a survey prepared and certified by a design professional of the existing roadway surface confirming that it is both level (2% maximum slope in any direction) and flat (all level changes of less than 1/4"). Current proposed ramp and landings do not meet requirements, reach out to Niki Green at ngreen@somervillema.gov with questions. Requirements can be found at <https://www.somervillema.gov/departments/licensing-commission>

RECORD COMMENT: NG 240312 This application includes a liquor license and non-contiguous premises that require ABCC approval before implementation.

COMPLETED IMM 240327: Platform construction plans provided. // NG 240312 Provide construction plans for any proposed structures (e.g., ramps), including structures with roofs, plans must be prepared and certified by a design professional.

COMPLETED IMM 240327: Plans revised. // NG 240312 Provide at least one accessible table or 10% of total outdoor seating in each license area, whichever is greater. Accessible tables shall be distributed by size and location throughout the license area (521 CMR 17.2) . Revise plans to indicate accessible tables.

COMPLETED IMM 240327: Plans revised. //NG 240312 Parklet Seating shall include reflective tape or reflective markers to the traffic facing sides of the Parklet structure or railings. Revise plans.

COMPLETED IMM 240328: Applicant no longer proposing dog area. // IMM 240327: Dog area not shown on revised plans, please clarify if you are proposing a dog area on outdoor seating, you license application shows this was being proposed. // NG 240312 Post a conspicuous sign to designate the outdoor dog area. Indicate on plan.

COMPLETED IMM 240327: Plans revised. //NG 240312 Parklet Seating shall include a railing separating the seating from the roadway. The railing shall meet the requirements of a Guard as defined by State Building Code (780 CMR, currently 9th Edition, 2015 IBC Sec. 1015).

COMPLETED IMM 240327: Plans revised. // NG 240312 Provide toilet capacity calculations, including both existing indoor seating and proposed outdoor seating counts, prepared and certified by a design professional or plumbing engineer currently licensed in Massachusetts (248 CMR 10.10 & 521 CMR 30.00). Toilet capacity calculations are reviewed by the Inspectional Services Department (ISD).

COMPLETED IMM 240328: Authorization received. // IMM 240327: Letter has not been received. // NG 240312 Revise plan to show location of neighboring tenants. If parklet occupies space in front of neighboring storefront, provide written permission by the adjacent

storefront and/or property tenant, and the neighboring property owner.

COMPLETED IMM 240328: Applicant confirmed via email that planters are removable. // IMM 240327: Sidewalk in front establishment used to have planters. Can you clarify if these planters are removable? We are trying to determine if the entrance proposed is clear of any obstacles. // NG 240312 Confirm whether existing planters are removable. Show all permanent furniture and fixtures on plan.

COMPLETED IMM 240328: Plans revised. // IMM 240327: Parklet Seating located on a constructed platforms shall be level (2% maximum slope in any direction), stable, firm and slip resistant, and connects to the sidewalk with a bridge plate that spans over the curb and provides a level change of less than ¼" (521 CMR 20). Revise plans to include bridge plate and provide manufacture's spec sheet for the bridge plate that will be installed on the entrance of the parklet. Minimum requirements are 4'x2' with a level change of less than ¼ inches (521 CMR 20). Please find spec detail attached.

APPROVAL CONDITION IMM 240327: After receiving approval, the Applicant shall fill out the Parking Department form to request Temporary No Parking Signs. To pick up the signs, print a copy of the submitted form and deliver to the Parking Department at 133 Holland St, Somerville MA 02144. Signs need to be posted at least 48h in advance. <https://bit.ly/ParkletParkingSigns>



Engineering Approval  
with Conditions  
Isabela Maia  
03/28/2024

251  
WASHINGTON  
STREET

SOMERVILLE, MA 02143

**MILITANA STUDIO**  
22 BIGELOW ST. #2B  
CAMBRIDGE, MA 02139  
T: 857.274.7493

NOTE:

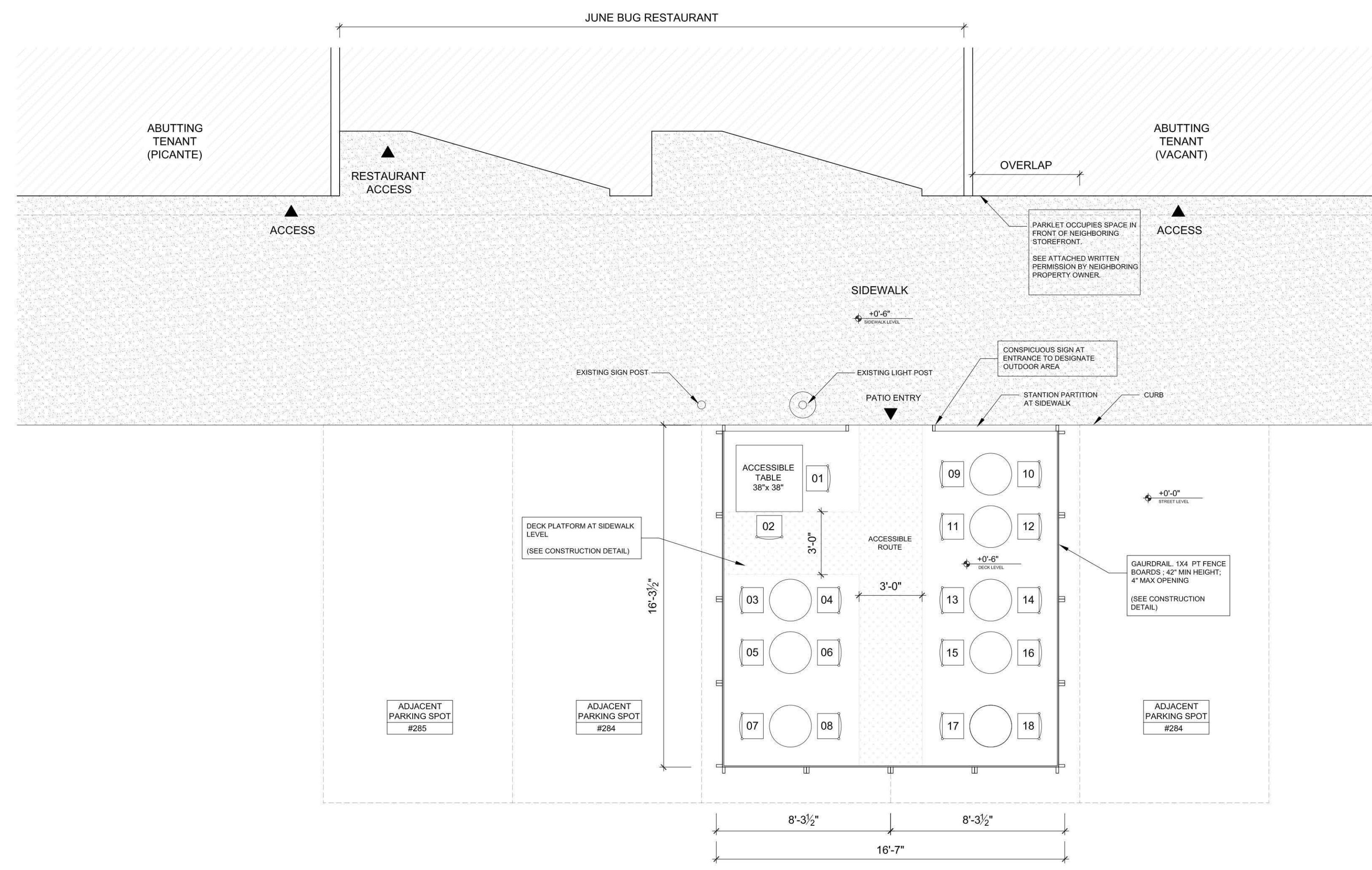

NOTES:

1. ALL FURNITURE, PLANTERS AND STRUCTURES WILL BE REMOVED AT END OF SEASONS.
2. ALL PARKLET SEATING WILL INCLUDE REFLECTIVE TAPE OR REFLECTIVE MARKERS TO THE TRAFFIC FACING SIDES OF THE PARKLET STRUCTURE AS PER REQUIREMENT NG 240312

OCCUPANT LOAD:

54 INDOOR  
18 OUTDOOR  
72 TOTAL

LAVATORY REQUIREMENTS:

1 UNISEX WATER CLOSET IS REQUIRED PER 45 OCCUPANTS  
JUNEBUG PROVIDES 2 UNISEX WATER CLOSETS FOR 72 OCCUPANTS

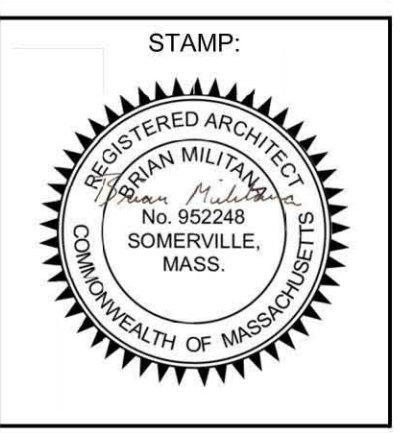

REVISION		
REV	DATE	DESCRIPTION

**SEASONAL PATIO  
PLAN PROPOSAL**

ISSUED BY  
MILITANA STUDIO

PROJECT NUMBER: 029 SHEET: A1.00

DRAWING DATE: 03/26/24

SCALE: 1/4" = 1'-0"



REV	DATE	DESCRIPTION

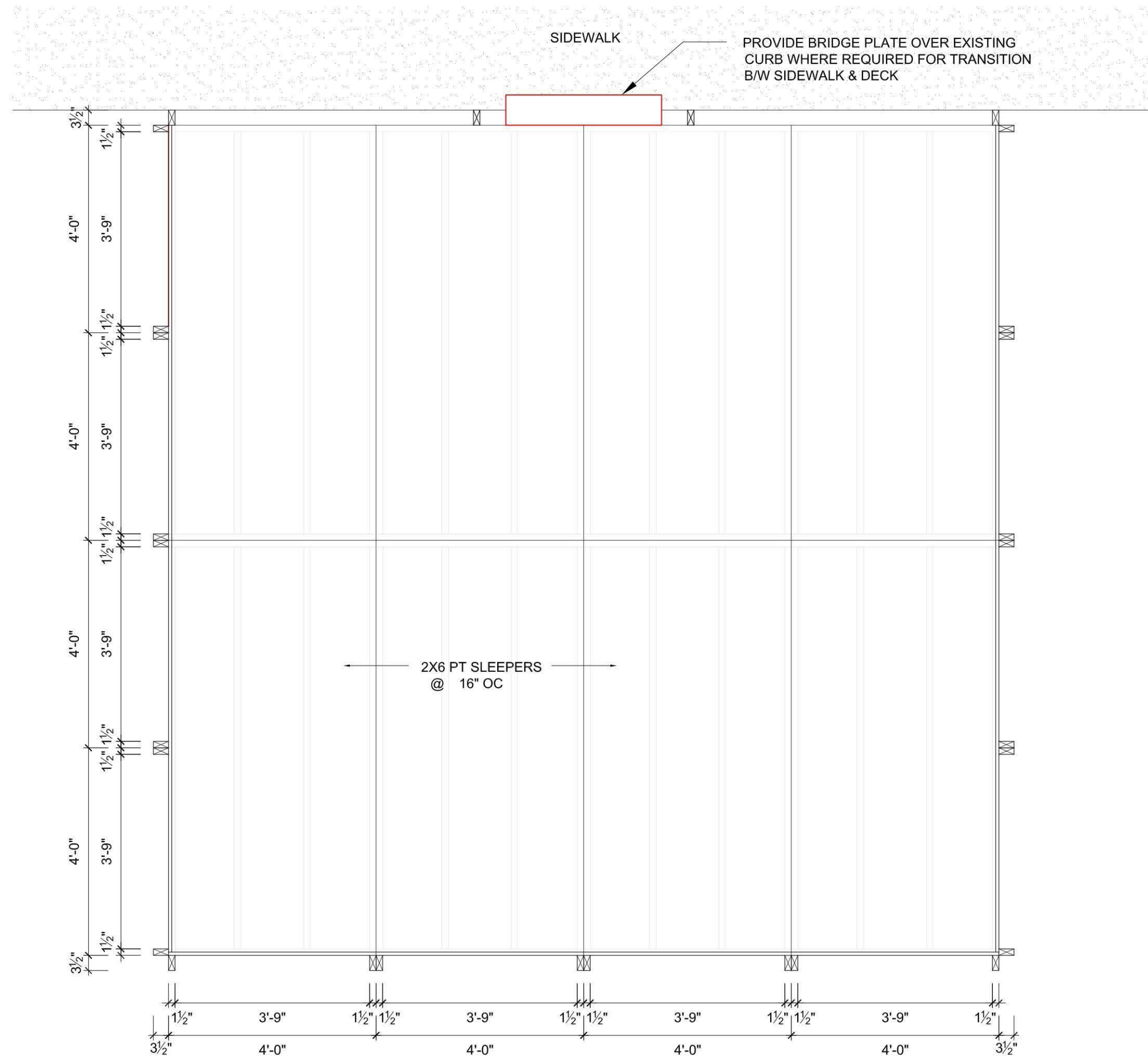

1 FRAMING LAYOUT  
A6.10 SCALE: 1/2" = 1'-0"

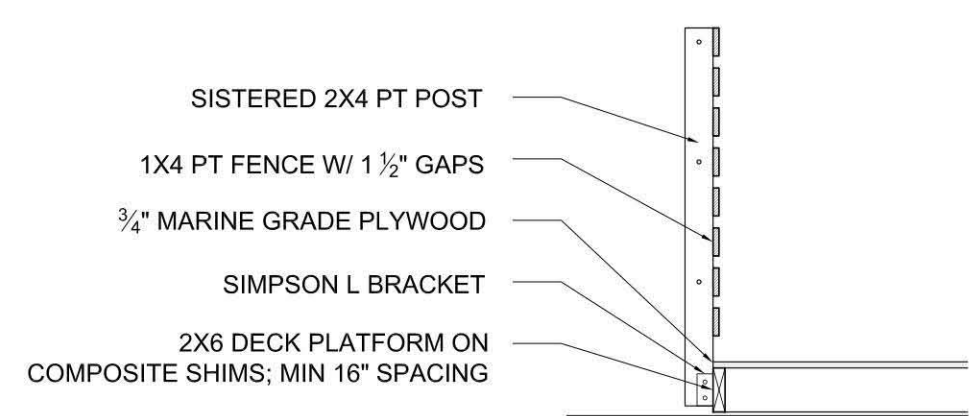

3 DECK SECTION  
A6.10 SCALE: 1/2" = 1'-0"

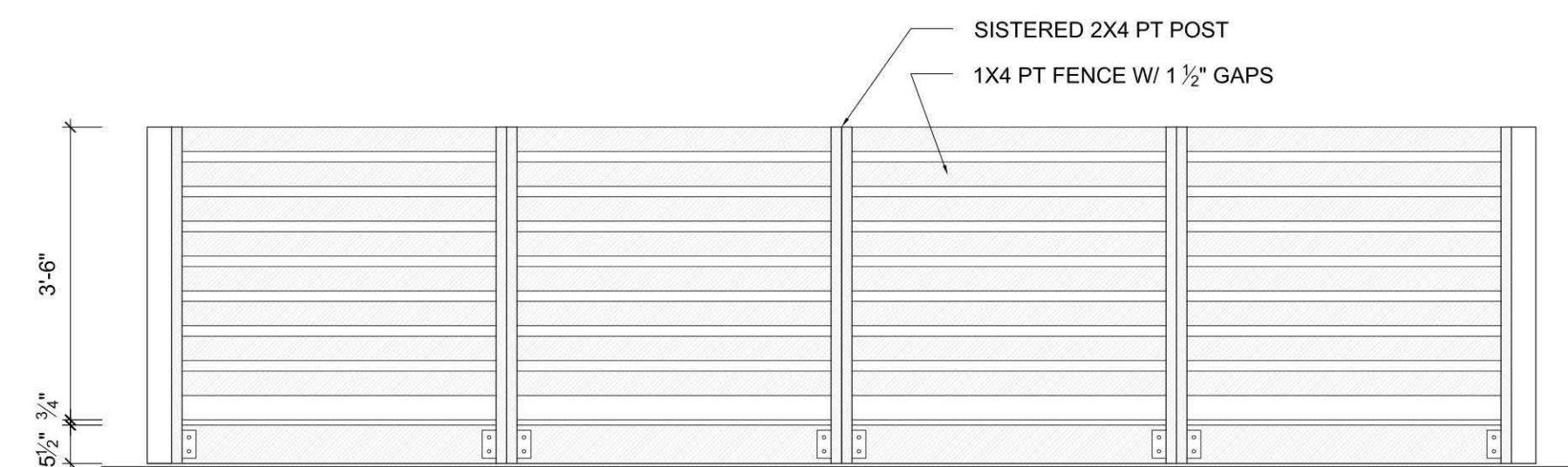

2 GAURDRAIL ELEVATION  
A6.10 SCALE: 1/2" = 1'-0"

# LICENSING COMMISSION LICENSE APPLICATION

City of Somerville, Commonwealth of Massachusetts

Application #: ALM24-000024

File #: 19-012853

**Business Name:** Rockwell Restaurant Group LLC dba  
Foundry on Elm

**Amendment Type:** Altering Premises or Outdoor Seating

**Location:** 255 ELM ST

---

## APPLICANT

**Company Name:** Rockwell Rest Group LLC dba Foundry on Elm,  
Saloon, The Rockwell

**Business Address:**  
73 Union Square  
Somerville, MA 02144

<b>Enter your current business license #</b>	AL17-000083
<b>Do you currently serve alcohol?</b>	Yes
<b>ARE YOU CHANGING THE NAME OF YOUR BUSINESS?</b>	No
<b>ARE YOU CHANGING YOUR MANAGER?</b>	No
<b>ARE YOU TRANSFERRING/ISSUING/PLEDGING STOCK, OR ARE YOU CHANGING DIRECTORS/OFFICERS/PARTNERS /TRUSTEES?</b>	No
<b>ARE YOU ALTERING YOUR EXISTING PREMISES OR OUTDOOR SEATING? SELECT YES TO INLCUDE OUTDOOR SEATING FOR LICENSE</b>	Yes
<b>Are you changing your indoor premises?</b>	No
<b>Are you changing your outdoor premises?</b>	Yes
<b>Parklet</b>	Yes
<b>Proposed number of seats on parklet</b>	24
<b>Proposed number of tables on parklet</b>	11
<b>Proposed square footage of parklet</b>	338
<b>Are you adding any tents larger than 10 feet by 12 feet?</b>	No
<b>Are you adding igloos or dome like structures?</b>	No
<b>Are you adding, removing, or changing the location of any barriers or perimeters around the outdoor seating?</b>	On public property
<b>Are you adding any heating elements?</b>	No
<b>Will you have a designated dog area?</b>	No
<b>Do you operate an inn?</b>	No
<b>Describe your outreach to the Ward Alderman and neighborhood</b>	N/A
<b>ARE YOU ADDING, OR ENDING, THE SERVICE OF</b>	No

**CORDIALS AND LIQUEURS?**

**ARE YOU CHANGING YOUR HOURS OF OPERATION?** No

**ARE YOU CHANGING YOUR ENTERTAINMENT?** No

**Total Devices indoors** 0

**Total Devices Outdoors** 0.0

**Have you ever received a Notice of Violation?** No

**almln the last 5 years, have you been found guilty, liable, or responsible, in any judicial or administrative proceeding, for any violation of the City Wage Theft Ordinance or any State or Federal laws or regulations regulating the payment of wages?**

**You must read and accept the above stated terms & conditions** Yes

**You must read and accept the above stated terms & conditions** Yes

**Approved By:**

Engineering Approval  
Niki Green  
04/02/2024

CLIENT  
**FOUNDRY ON ELM**

CONSULTANT

SEAL



PROJECT INFORMATION  
**FOUNDRY ON ELM PARKLET**

255 ELM ST.  
SOMERVILLE, MA. 02144

**FOR PERMIT**

3/19/2024 11:41:49 AM

WARNING: Joe The Architect, Inc., all drawings and written material herein constitute the original and unpublished work of the architect, and the same may not be duplicated, used, or disclosed without the written consent of the architect. Contractors to use Architectural Drawings for set out. Contractors to check and verify all Dimensions on Site prior to Construction/Fabrication. Figure Dimensions take precedence over Scaled Dimensions. Any discrepancies should be immediately referred to the Architect. The project manager shall be notified in writing of any discrepancies prior to proceeding with the work. The scale of drawings may change when copied or faxed. All work to comply with I.B.C. Regulations and relevant American Standards. © 2024 - all rights reserved.

ISSUE CHART

ISSUE	DATE
PROJECT NUMBER	621
CHECKER	Checked
APPROVED	Approver
SCALE	1/2" = 1'-0"
SHEET NAME	

**PATIO PLAN**

SHEET NUMBER

**A001**

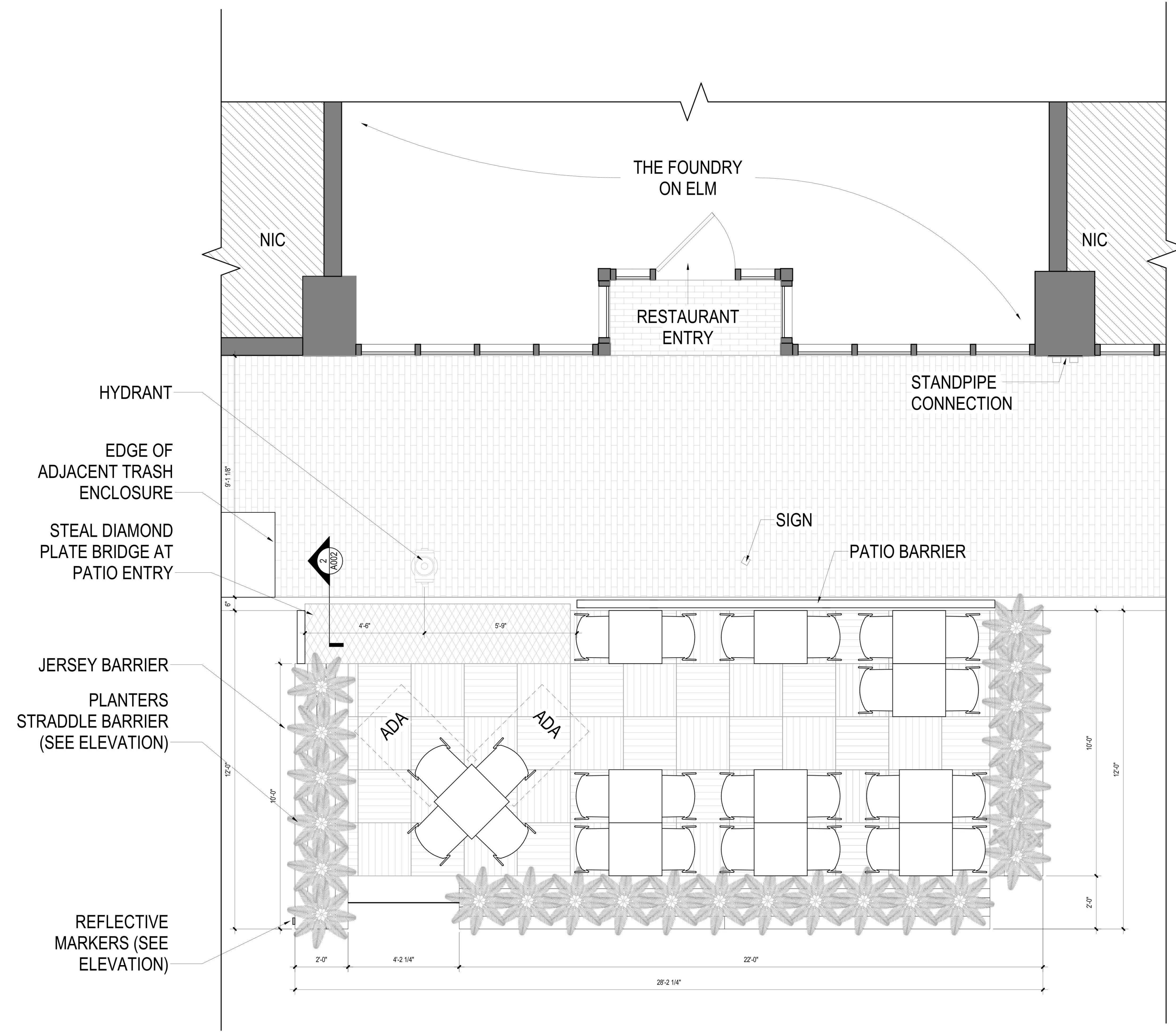

CLIENT

**FOUNDRY ON ELM**

CONSULTANT

SEAL



PROJECT INFORMATION

**FOUNDRY ON ELM PARKLET**

255 ELM ST.  
 SOMERVILLE, MA. 02144

**FOR PERMIT**

3/19/2024 11:41:49 AM

WARNING:  
 Joe The Architect, Inc. all drawings and written material herein constitute the original and unpublished work of the architect and the same may not be duplicated, used, or disclosed without the written consent of the architect. Contractors to use Architectural Drawings for set out. Contractors to check and verify all Dimensions on Site prior to Construction/Fabrication. Figure Dimensions take precedence over Scaled Dimensions. Any discrepancies should be immediately referred to the Architect. The project manager shall be notified in writing of any discrepancies prior to proceeding with the work. The scale of drawings may change when copied or faxed. All work to comply with I.B.C. Regulations and relevant American Standards. © 2024- all rights reserved

ISSUE CHART

ISSUE	DATE
PROJECT NUMBER	621
CHECKER	
APPROVER	
SCALE	As indicated
SHEET NAME	

**PATIO ELEVATION & DTL. SECTION**

SHEET NUMBER

**A002**

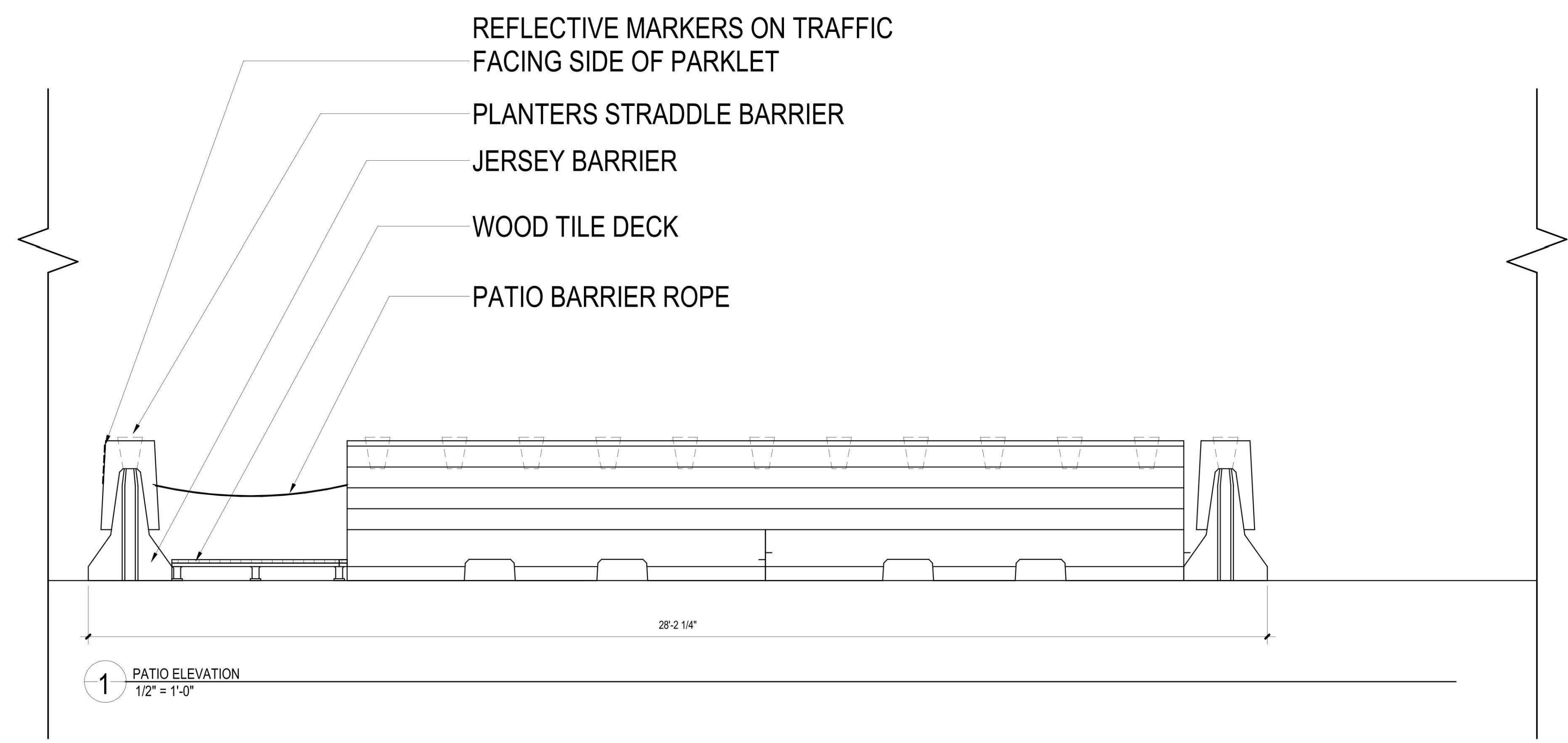

**1** PATIO ELEVATION  
 1/2" = 1'-0"

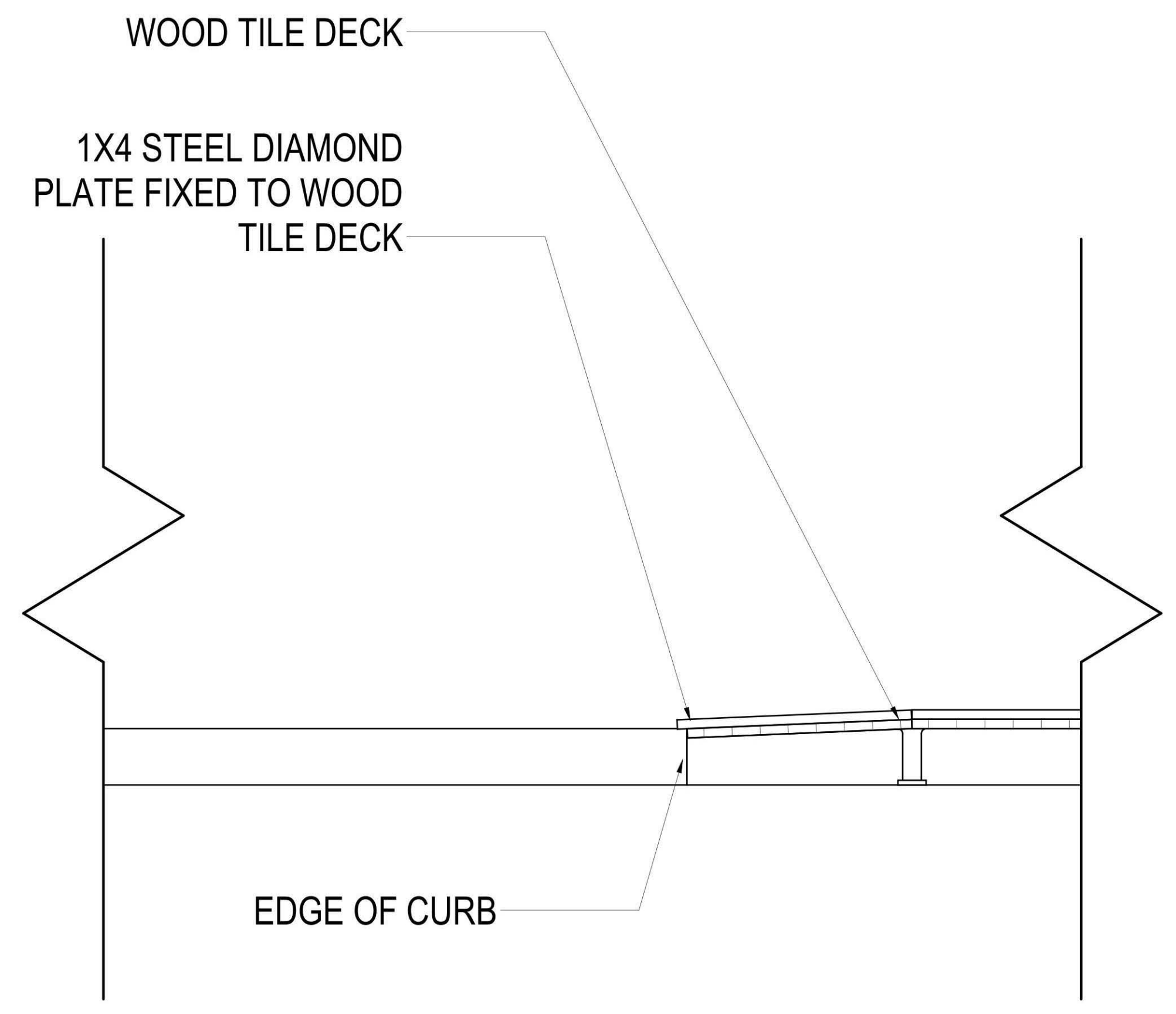

**2** DTL. SECTION  
 1" = 1'-0"

CLIENT

**FOUNDRY ON ELM**

CONSULTANT

SEAL

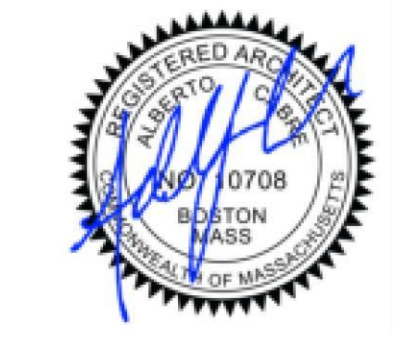

PROJECT INFORMATION

**FOUNDRY ON ELM PARKLET**

255 ELM ST.  
 SOMERVILLE, MA. 02144

**FOR PERMIT**

3/19/2024 11:41:50 AM

WARNING:  
 Joe The Architect, Inc. all drawings and written material herein constitute the original and unpublished work of the architect, and the same may not be duplicated, used, or disclosed without the written consent of the architect. Contractors to use Architectural Drawings for set out. Contractors to check and verify all Dimensions on Site prior to Construction/Fabrication. Figure Dimensions take precedence over Scaled Dimensions. Any discrepancies should be immediately referred to the Architect. The project manager shall be notified in writing of any discrepancies prior to proceeding with the work. The scale of drawings may change when copied or saved. All work to comply with I.B.C. Regulations and relevant American Standards. © 2021- all rights reserved

ISSUE CHART

ISSUE	DATE
PROJECT NUMBER	621
CHECKER	Checker
APPROVED	Approver
SCALE	
SHEET NAME	

**PATIO IMAGES**

SHEET NUMBER

**A003**



# LICENSING COMMISSION LICENSE APPLICATION

City of Somerville, Commonwealth of Massachusetts

Application #: ALM24-000019

File #: 17-013296

**Business Name:** LDDJ inc. Dave's Fresh Pasta

**Amendment Type:** Pledging Stock or License, Changing Owners, Officers or Directors, Changing Manager

**Location:** 79-83 HOLLAND ST

---

## APPLICANT

**Company Name:** Dave's Fresh Pasta

**Business Address:**

79-83 Holland St.  
Somerville, MA 02144

**Enter your current business license #** AL17-000155

**Do you currently serve alcohol?** No

**ARE YOU CHANGING THE NAME OF YOUR BUSINESS?** No

**ARE YOU CHANGING YOUR MANAGER?** Yes

**Name of old manager** David Jick

**Name of new manager** Joshua Sarvis

**ARE YOU TRANSFERRING/ISSUING/PLEDGING STOCK, OR ARE YOU CHANGING DIRECTORS/OFFICERS/PARTNERS/TRUSTEES?** Yes

**Are you transferring/issuing/pledging stock?** Yes

**Describe the transaction, including the names of all parties** Two stockholders (David Jick and Lori Deliso, husband and wife) will sell 35.88 shares collectively (17.94 each) of there total 88.26 shares to Joshua Sarvis at closing for cash with the remainder sold by installment terms of a stock purchase agreement. Joshua is president, David Jick is secretary, both are directors. The license manager will be Joshua Sarvis.

**Are you changing directors/officers/partners/trustees?** Yes

**List the current directors/officers/partners/trustees with their titles** David Jick, President Lori Deliso, Treasurer

**List the proposed directors/officers/partners/trustees with their titles** Joshua Sarvis, President David Jick, Secretary

**ARE YOU ALTERING YOUR EXISTING PREMISES OR OUTDOOR SEATING? SELECT YES TO INLCUDE OUTDOOR SEATING FOR LICENSE** No

**ARE YOU ADDING, OR ENDING, THE SERVICE OF CORDIALS AND LIQUEURS?** No

**ARE YOU CHANGING YOUR HOURS OF OPERATION?** No

**ARE YOU CHANGING YOUR ENTERTAINMENT?** No

**Total Devices indoors** 0

**Total Devices Outdoors** 0.0

**Have you ever received a Notice of Violation?** No



alIn the last 5 years, have you been found guilty, liable, or responsible, in any judicial or administrative proceeding, for any violation of the City Wage Theft Ordinance or any State or Federal laws or regulations regulating the payment of wages?  
[City Wage Theft Ordinance](..\Documents\149\WAGE%20THEFT%20ORDINANCE.pdf)

No

You must read and accept the above stated terms & conditions

Yes

You must read and accept the above stated terms & conditions

Yes

**Approved By:**

# LICENSING COMMISSION LICENSE APPLICATION

City of Somerville, Commonwealth of Massachusetts

Application #: ALM24-000014

File #: 23-015262

**Business Name:** Carlos & Mike, Inc. d/b/a The Cornerstone

**Amendment Type:** Pledging Stock or License, Changing Owners, Officers or Directors

**Location:** 282 BEACON ST

---

## APPLICANT

**Company Name:** Carlos & Mike Inc dba Fang's Restaurant

**Business Address:**

66 Hillsdale Road  
Medford, MA 02155

**Enter your current business license #** AL22-000040

**Do you currently serve alcohol?** Yes

**ARE YOU CHANGING THE NAME OF YOUR BUSINESS?** No

**ARE YOU CHANGING YOUR MANAGER?** No

**ARE YOU TRANSFERRING/ISSUING/PLEDGING STOCK, OR ARE YOU CHANGING DIRECTORS/OFFICERS/PARTNERS/TRUSTEES?** Yes

**Are you transferring/issuing/pledging stock?** Yes

**Describe the transaction, including the names of all parties** The corporation's stock previously was owned by Hsuanwei Fang and Juan Carlos Vidal, both of whom have been and are remaining directors. Hsuanwei Fang recently sold his shares to Juan Carlos Vidal, who now owns 100% of the stock. Mr. Fang remains a director with Mr. Vidal. Mr. Vidal also now holds the positions of President, Treasurer, and Secretary.

**Are you changing directors/officers/partners/trustees?** Yes

**List the current directors/officers/partners/trustees with their titles** Hsuanwei Fang: Treasurer, Secretary, Director Juan Carlos Vidal: President, Director

**List the proposed directors/officers/partners/trustees with their titles** Hsuanwei Fang: Director Juan Carlos Vidal: President, Treasurer, Secretary, Director

**ARE YOU ALTERING YOUR EXISTING PREMISES OR OUTDOOR SEATING? SELECT YES TO INCLUDE OUTDOOR SEATING FOR LICENSE** No

**ARE YOU ADDING, OR ENDING, THE SERVICE OF CORDIALS AND LIQUEURS?** No

**ARE YOU CHANGING YOUR HOURS OF OPERATION?** No

**ARE YOU CHANGING YOUR ENTERTAINMENT?** No

**Total Devices indoors** 0

**Total Devices Outdoors** 0.0

**Have you ever received a Notice of Violation?** No

**alIn the last 5 years, have you been found guilty, liable, or responsible, in any judicial or administrative proceeding, for any violation of the City Wage Theft Ordinance or any State or Federal laws or regulations regulating the payment of wages?** No

[City Wage Theft Ordinance](http://Documents/149/WAGE%20THEFT%20ORDINANCE.pdf)

You must read and accept the above stated terms & conditions Yes

You must read and accept the above stated terms & conditions Yes

**Approved By:**

# LICENSING COMMISSION LICENSE APPLICATION

City of Somerville, Commonwealth of Massachusetts

Application #: AL24-000005

File #: 24-004657

**Business Name:** Eat Greek, LLC

**Application Type:** Restaurant (with alcohol)

**Location:** 215 ELM ST

---

## APPLICANT

**Company Name:** EAT GREEK LLC

**Business Address:**

215 ELM ST

SOMERVILLE , MA 02144

**Legal Name of the Proposed Licenseholder (Name of Corporation, LLC, Partnership/LLP, Trust, Sole Proprietor, Other)**

Eat Greek, LLC

**DBA Name**

Eat Greek Gyros

**In the last 5 years, have you been found guilty, liable, or responsible, in any judicial or administrative proceeding, for any violation of the City Wage Theft Ordinance or any State or Federal laws or regulations regulating the payment of wages?**

No

**Manager of your establishment**

Roland Leci

**Will you offer seating for the consumption of food on premises? (Food includes non-alcoholic beverages)**

Yes

**Number of floors on the premises**

1

**Name of floor (Basement, balcony, Main, 2nd floor, etc.)<sup>1</sup>**

Main

**Number of rooms<sup>1</sup>**

1

**Square footage<sup>1</sup>**

1599

**Number of seats (enter 0 if you are not serving food on premises)<sup>1</sup>**

42

**Square footage<sup>2</sup>**

0

**Use of Public Space Square Footage 150sqft or less**

150

**Use of Public Space Square Footage over 150sqft**

133

**Number of entrances into the indoor premises**

1

**Number of exits from the indoor premises**

2

**Will you offer seating outdoors in season?**

On public property

**Number of seats outdoors on public property**

16

**Square footage outdoors on public property**

283

**Are you installing any large tents (larger than 10' X 12')**

No

**Are you installing any domes or dome-like structures**

No

<b>Are you installing any barriers or perimeters around the outdoor seating</b>	On public property
<b>Describe each barrier or perimeter on public property, including its length and width</b>	13 6 foot long Planters
<b>Number of seating areas bounded by barriers or perimeters on public property</b>	1
<b>Are you installing any heating elements</b>	No
<b>Number of rooms indoors</b>	1
<b>Total square footage indoors</b>	1599
<b>Total seating capacity indoors</b>	42
<b>Total square footage outdoors</b>	283
<b>Total seating capacity outdoors</b>	16
<b>Total seating capacity</b>	58
<b>Are you an Educational Institution?</b>	No
<b>Are you a Farmer Pourer?</b>	No
<b>Are you a Package Store?</b>	No
<b>Are you a Private Club?</b>	No
<b>Are you a Restaurant/Common Victualer?</b>	Yes
<b>Are you an Inn?</b>	No
<b>Days and hours of operation to serve, sell or distribute alcohol indoors</b>	Sunday-Saturday:12:00 p.m. until 12:30 a.m.
<b>1. Sunday (From - Time)</b>	12:00
<b>1. Sunday (From - AM/PM)</b>	PM
<b>1. Sunday (To - Time)</b>	12:30
<b>1. Sunday (To - AM/PM)</b>	AM
<b>1. Monday (From - Time)</b>	12:00
<b>1. Monday (From - AM/PM)</b>	PM
<b>1. Monday (To - Time)</b>	12:30
<b>1. Monday (To - AM/PM)</b>	AM
<b>1. Tuesday (From - Time)</b>	12:00
<b>1. Tuesday (From - AM/PM)</b>	PM
<b>1. Tuesday (To - Time)</b>	12:30
<b>1. Tuesday (To - AM/PM)</b>	AM
<b>1. Wednesday (From - Time)</b>	12:00
<b>1. Wednesday (From - AM/PM)</b>	PM
<b>1. Wednesday (To - Time)</b>	12:30
<b>1. Wednesday (To - AM/PM)</b>	AM
<b>1. Thursday (From - Time)</b>	12:00

<b>1. Thursday (From - AM/PM)</b>	PM
<b>1. Thursday (To - Time)</b>	12:30
<b>1. Thursday (To - AM/PM)</b>	AM
<b>1. Friday (From - Time)</b>	12:00
<b>1. Friday (From - AM/PM)</b>	PM
<b>1. Friday (To - Time)</b>	12:30
<b>1. Friday (To - AM/PM)</b>	AM
<b>1. Saturday (From - Time)</b>	12:00
<b>1. Saturday (From - AM/PM)</b>	PM
<b>1. Saturday (To - Time)</b>	12:30
<b>1. Saturday (To - AM/PM)</b>	AM
<b>Days and hours of operation to serve food indoors</b>	Sunday - Saturday:11:00 a.m. until 12:30 a.m.
<b>2. Sunday (From - Time)</b>	11:00
<b>2. Sunday (From - AM/PM)</b>	AM
<b>2. Sunday (To - Time)</b>	12:30
<b>2. Sunday (To - AM/PM)</b>	AM
<b>2. Monday (From - Time)</b>	11:00
<b>2. Monday (From - AM/PM)</b>	AM
<b>2. Monday (To - Time)</b>	12:30
<b>2. Monday (To - AM/PM)</b>	AM
<b>2. Tuesday (From - Time)</b>	11:00
<b>2. Tuesday (From - AM/PM)</b>	AM
<b>2. Tuesday (To - Time)</b>	12:30
<b>2. Tuesday (To - AM/PM)</b>	AM
<b>2. Wednesday (From - Time)</b>	11:00
<b>2. Wednesday (From - AM/PM)</b>	AM
<b>2. Wednesday (To - Time)</b>	12:30
<b>2. Wednesday (To - AM/PM)</b>	AM
<b>2. Thursday (From - Time)</b>	11:00
<b>2. Thursday (From - AM/PM)</b>	AM
<b>2. Thursday (To - Time)</b>	12:30
<b>2. Thursday (To - AM/PM)</b>	AM
<b>2. Friday (From - Time)</b>	11:00
<b>2. Friday (From - AM/PM)</b>	AM
<b>2. Friday (To - Time)</b>	12:30
<b>2. Friday (To - AM/PM)</b>	AM
<b>2. Saturday (From - Time)</b>	11:00

<b>2. Saturday (From - AM/PM)</b>	AM
<b>2. Saturday (To - Time)</b>	12:30
<b>2. Saturday (To - AM/PM)</b>	AM
<b>Days and hours of operation to serve food outdoors on public property</b>	Sunday -Saturday:11:00 a.m. until 12:30 a.m.
<b>4. Sunday (From - Time)</b>	11:00
<b>4. Sunday (From - AM/PM)</b>	AM
<b>4. Sunday (To - Time)</b>	12:30
<b>4. Sunday (To - AM/PM)</b>	AM
<b>4. Monday (From - Time)</b>	11:00
<b>4. Monday (From - AM/PM)</b>	AM
<b>4. Monday (To - Time)</b>	12:30
<b>4. Monday (To - AM/PM)</b>	AM
<b>4. Tuesday (From - Time)</b>	11:00
<b>4. Tuesday (From - AM/PM)</b>	AM
<b>4. Tuesday (To - Time)</b>	12:30
<b>4. Tuesday (To - AM/PM)</b>	AM
<b>4. Wednesday (From - Time)</b>	11:00
<b>4. Wednesday (From - AM/PM)</b>	AM
<b>4. Wednesday (To - Time)</b>	12:30
<b>4. Wednesday (To - AM/PM)</b>	AM
<b>4. Thursday (From - Time)</b>	11:00
<b>4. Thursday (From - AM/PM)</b>	AM
<b>4. Thursday (To - Time)</b>	12:30
<b>4. Thursday (To - AM/PM)</b>	AM
<b>4. Friday (From - Time)</b>	11:00
<b>4. Friday (From - AM/PM)</b>	AM
<b>4. Friday (To - Time)</b>	12:30
<b>4. Friday (To - AM/PM)</b>	AM
<b>4. Saturday (From - Time)</b>	11:00
<b>4. Saturday (From - AM/PM)</b>	AM
<b>4. Saturday (To - Time)</b>	12:30
<b>4. Saturday (To - AM/PM)</b>	AM
<b>Describe your food services (table service, counter service, cafeteria, packaged food only, etc)</b>	Table Service and Counter Service
<b>Will you serve alcohol?</b>	All Forms
<b>Do you want to open Sundays to serve, sell or distribute alcohol between 10:00 AM and 11:59 AM?</b>	No

<b>Do you want to open on New Years Eve until 2 AM? (contingent on Licensing Commission approval)</b>	No
<b>Will you serve alcohol outdoors in season?</b>	On Public Property
<b>Days and hours of operation to serve alcohol outdoors on public property</b>	Sunday- Saturday:12:00 p.m. until 12:30 a.m.
<b>6. Sunday (From - Time)</b>	12:00
<b>6. Sunday (From - AM/PM)</b>	PM
<b>6. Sunday (To - Time)</b>	12:30
<b>6. Sunday (To - AM/PM)</b>	AM
<b>6. Monday (From - Time)</b>	12:00
<b>6. Monday (From - AM/PM)</b>	PM
<b>6. Monday (To - Time)</b>	12:30
<b>6. Monday (To - AM/PM)</b>	AM
<b>6. Tuesday (From - Time)</b>	12:00
<b>6. Tuesday (From - AM/PM)</b>	PM
<b>6. Tuesday (To - Time)</b>	12:30
<b>6. Tuesday (To - AM/PM)</b>	AM
<b>6. Wednesday (From - Time)</b>	12:00
<b>6. Wednesday (From - AM/PM)</b>	PM
<b>6. Wednesday (To - Time)</b>	12:30
<b>6. Wednesday (To - AM/PM)</b>	AM
<b>6. Thursday (From - Time)</b>	12:00
<b>6. Thursday (From - AM/PM)</b>	PM
<b>6. Thursday (To - Time)</b>	12:30
<b>6. Thursday (To - AM/PM)</b>	AM
<b>6. Friday (From - Time)</b>	12:00
<b>6. Friday (From - AM/PM)</b>	PM
<b>6. Friday (To - Time)</b>	12:30
<b>6. Friday (To - AM/PM)</b>	AM
<b>6. Saturday (From - Time)</b>	12:00
<b>6. Saturday (From - AM/PM)</b>	PM
<b>6. Saturday (To - Time)</b>	12:30
<b>6. Saturday (To - AM/PM)</b>	AM
<b>Will you offer Entertainment indoors(recorded music, tvs, performers, djs, dancing, etc.)?</b>	Yes
<b>Describe the types of entertainment you will offer indoors</b>	Recorded Music
<b>Will the entertainment indoors be accessible to all ages and all classes of the public?</b>	No



<b>Explain</b>	Recorded Music not by music machine controlled through the public.
<b>Will you have entertainment devices indoors? (Stereos, TVs, movie screens, video games, etc.)</b>	No
<b>Total Devices indoors</b>	0
<b>Will you have live performers indoors? (Musicians, comedians, actors, athletes, contests, DJs, etc.)</b>	No
<b>Will the patrons perform indoors? (dancing, darts, karaoke, etc.)</b>	No
<b>Will you offer Entertainment outdoors(recorded music, tvs, performers, djs, dancing, etc.)?</b>	No
<b>Describe any other businesses serving alcohol on the premises</b>	None.
<b>Have you obtained an alcohol license before?</b>	Yes
<b>List each license with the city, state, and year first licensed</b>	License in Tewksbury, MA for a pizza restaurant (malt beer and wine only) in 2018.
<b>Have you ever had a license denied, revoked, or suspended?</b>	No
<b>Have you ever received a Notice of Violation?</b>	No
<b>Describe your outreach to the Ward of Alderman and the neighborhood</b>	To be determined.
<b>You must read and accept the above stated terms &amp; conditions</b>	Yes

Engineering Approval  
with Conditions  
Isabela Maia  
04/02/2024

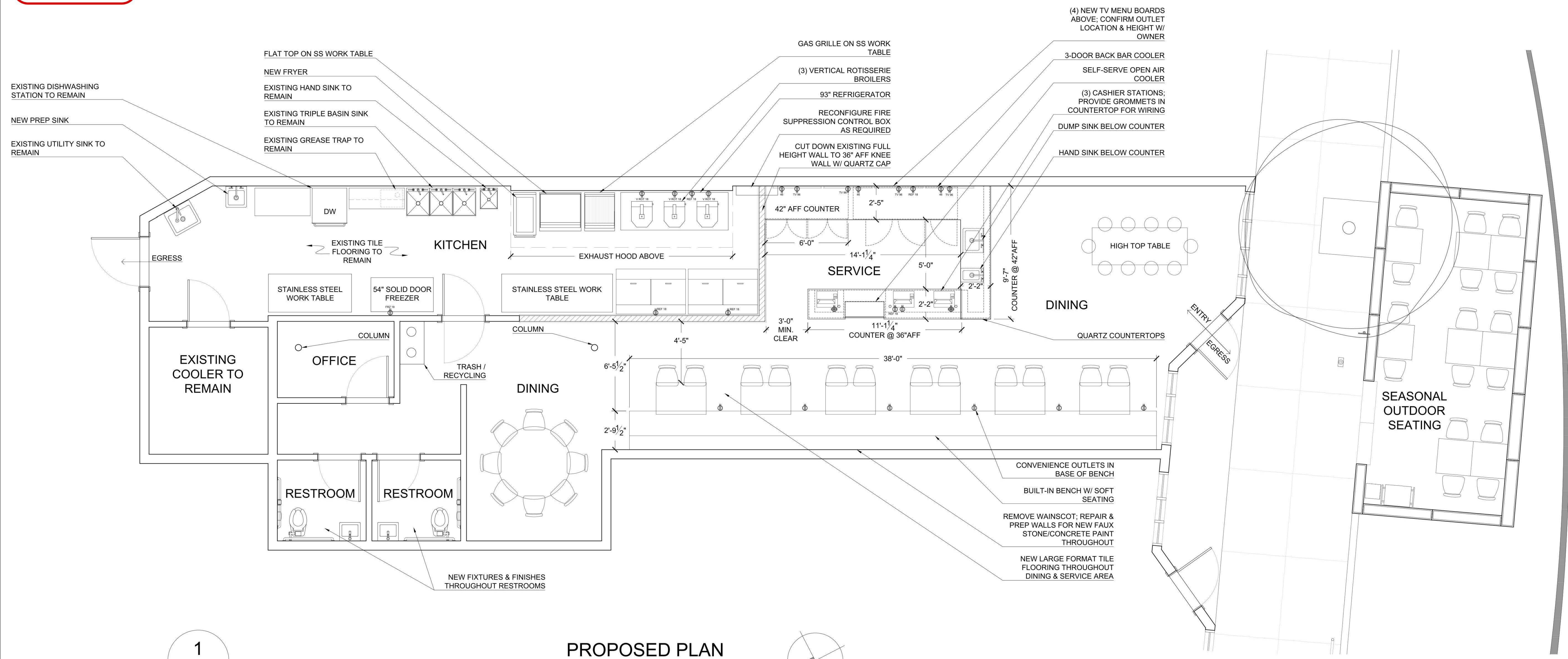

1  
A-100

**PROPOSED PLAN**  
1/4" = 1'-0"

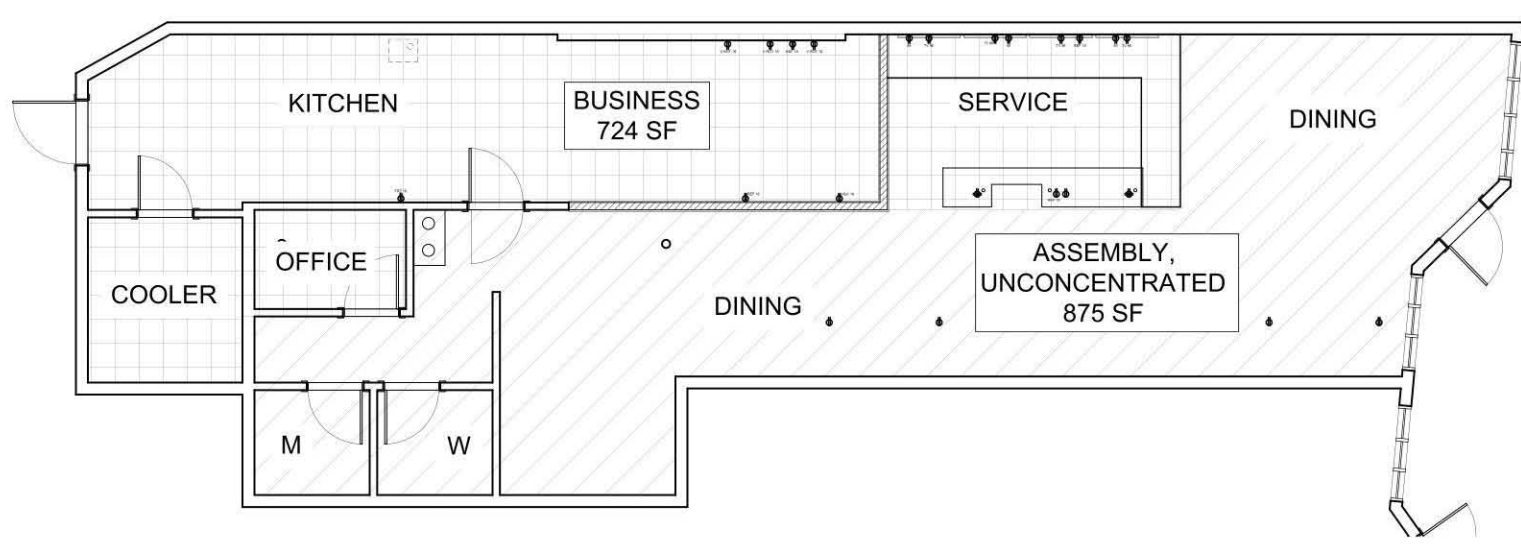
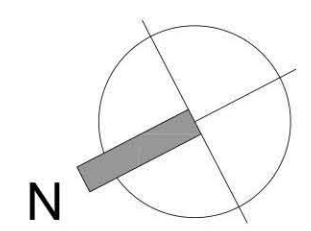

2  
A-100

**OCCUPANT LOAD**  
3/32" = 1'-0"

**DESIGN OCCUPANT LOAD (IBC TABLE 1004.2.1)**

FUNCTION	AREA	FACTOR	OCCUPANTS
ASSEMBLY, UNCONCENTRATED	875 SF	15 NET	59
BUSINESS	724 SF	100 GROSS	8
<b>TOTAL</b>	<b>1599 SF</b>		<b>67</b>

**REQUIRED TOILET CALCULATION**

TOILETS	OCCUPANTS	REQUIRED	EXISTING
FEMALES	67/2 = 34	1 PER 30 = 2	1
MALES	67/2 = 34	1 PER 60 = 1	1
<b>TOTAL</b>	<b>67</b>	<b>3</b>	<b>2 (NON CONFORMING)</b>



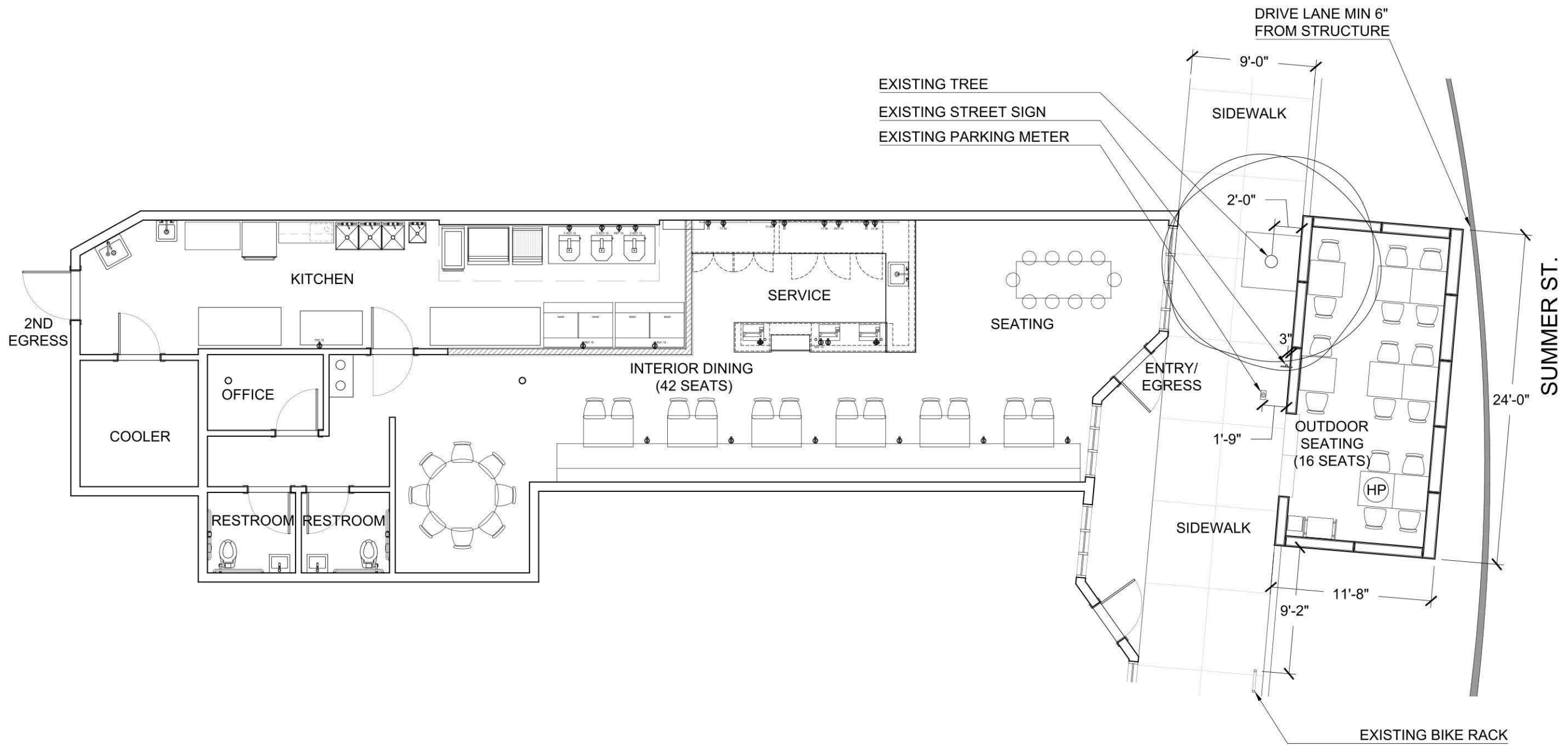

1  
A-102

GENERAL FLOOR PLAN  
1/8" = 1'-0"

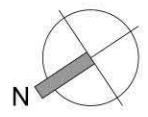

**MAXWELL ARCHITECTS, LLC**  
PLANNING / PROGRAMMING / DESIGN

Architecture  
Space Planning  
Project Management  
Facility Programming

20 Windom Street  
Somerville, Massachusetts 02144  
(617) 666-9222  
(617) 666-4557 FAX

Copyright © 2024 by Maxwell Architects, LLC All rights reserved.

GENERAL FLOOR PLAN  
EAT GREEK  
215 ELM STREET  
SOMERVILLE, MA 02144



PROJECT NUMBER: 2408  
DRAWING NUMBER:  
**A-102**  
SCALE: 1/8" = 1'-0"  
DATE: 03.15.2024

**OUTDOOR SEATING FLOOR PLAN**  
**EAT GREEK**  
 215 ELM STREET  
 SOMERVILLE, MA 02144



PROJECT NUMBER: 2408  
 DRAWING NUMBER:  
**A-103**  
 SCALE: 1/8" = 1'-0"  
 DATE: 03.15.2024

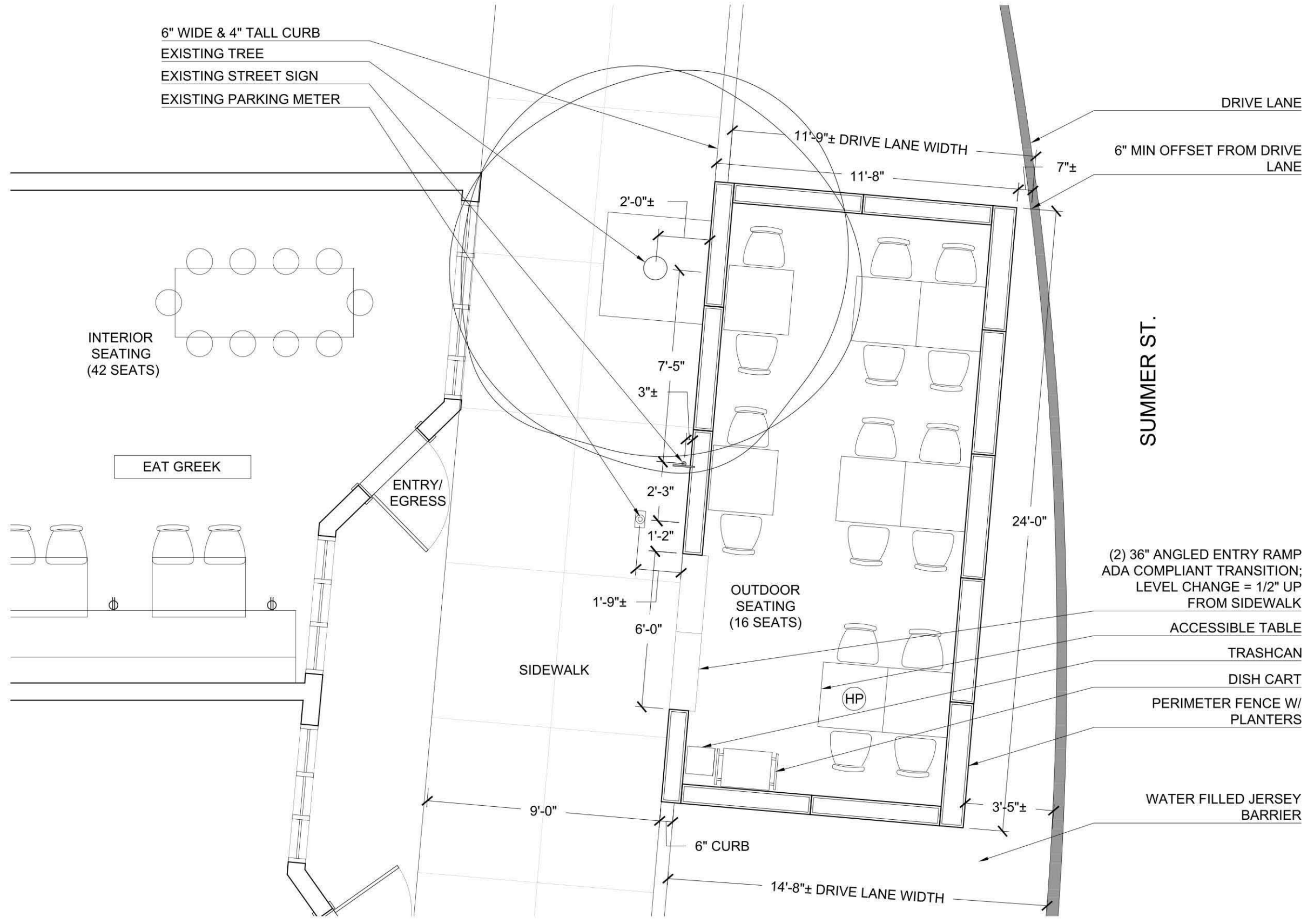

**1**  
**A-103**

**OUTDOOR SEATING FLOOR PLAN**  
 1/8" = 1'-0"

N

**OUTDOOR PLATFORM STRUCTURE**  
**EAT GREEK**  
**215 ELM STREET**  
**SOMERVILLE, MA 02144**



PROJECT NUMBER: 2408  
 DRAWING NUMBER:  
**A-104**  
 SCALE: 1/8" = 1'-0"  
 DATE: 03.15.2024

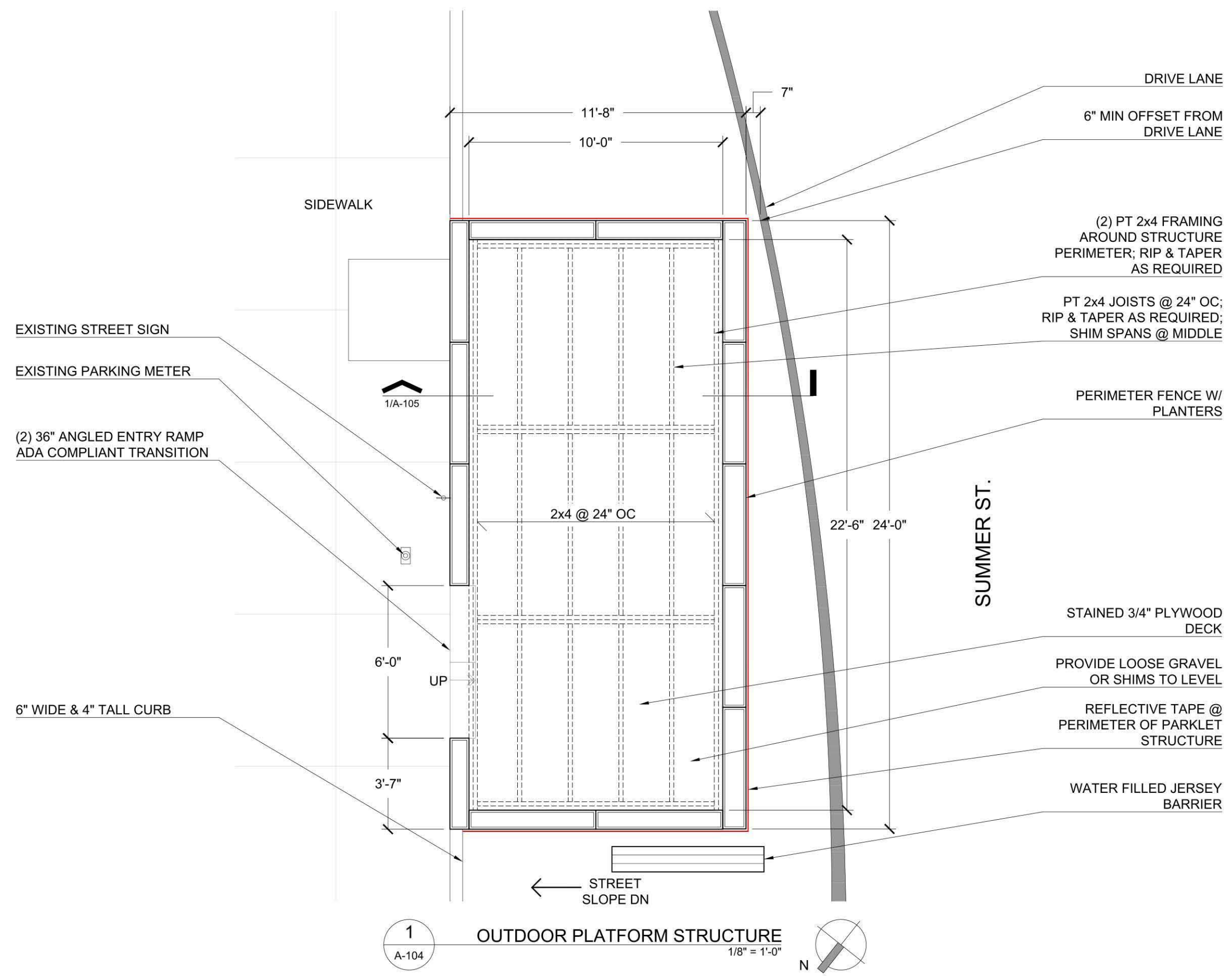

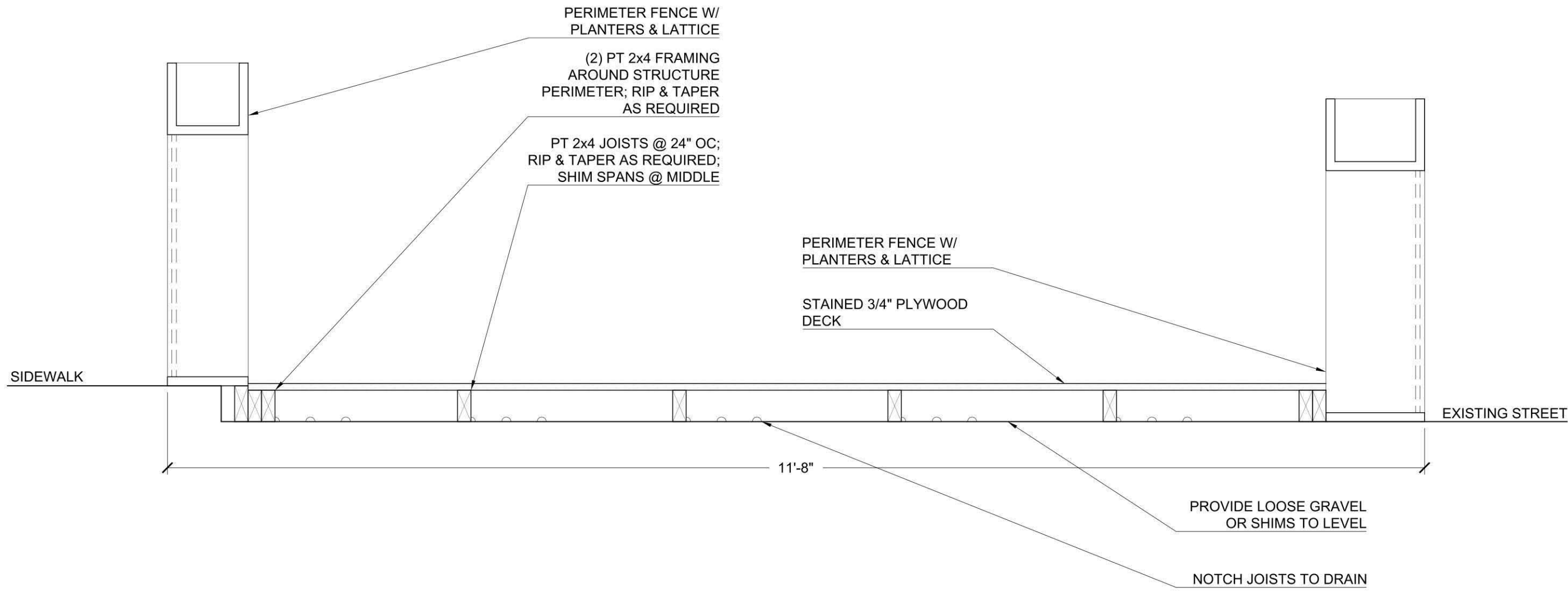

PERIMETER FENCE W/  
PLANTERS & LATTICE

(2) PT 2x4 FRAMING  
AROUND STRUCTURE  
PERIMETER; RIP & TAPER  
AS REQUIRED

PT 2x4 JOISTS @ 24" OC;  
RIP & TAPER AS REQUIRED;  
SHIM SPANS @ MIDDLE

PERIMETER FENCE W/  
PLANTERS & LATTICE

STAINED 3/4" PLYWOOD  
DECK

PROVIDE LOOSE GRAVEL  
OR SHIMS TO LEVEL

NOTCH JOISTS TO DRAIN

1  
A-105

SECTION  
1" = 1'-0"

**MAXWELL ARCHITECTS, LLC**  
PLANNING / PROGRAMMING / DESIGN

Architecture  
Space Planning  
Project Management  
Facility Programming

20 Windom Street  
Somerville, Massachusetts 02144  
(617) 666-9222  
(617) 666-4557 FAX

Copyright © 2024 by Maxwell Architects, LLC All rights reserved.

SECTION  
EAT GREEK  
215 ELM STREET  
SOMERVILLE, MA 02144



PROJECT NUMBER: 2408  
DRAWING NUMBER:  
**A-105**  
SCALE: 1" = 1'-0"  
DATE: 03.15.2024

# Eat Greek Gyros

215 Elm Street Somerville, MA

## Gyros



### Pita Gyros

Warm pitas served with your choice of filling, tzatziki sauce, tomatoes, onions and french fries.

Pork	\$14.75
Chicken	\$14.75
Souvlaki/Skewer Pork	\$14.75
Souvlaki Chicken	\$14.75
Halloumi	\$14.75
Loukaniko	\$14.75
Chicken Bacon	\$14.75
Mix Chicken and Pork	\$14.75

## Dinner Plates

Served with tomatoes, onions, French Fries or Rice Pilaf, warm pita bread and choice of Tzatziki, Tirokafteri or Eat Greek Sauce.

Pork Gyro	\$23.99
Chicken Gyro	\$23.99
Souvlaki Pork	\$23.99
Souvlaki Chicken	\$23.99
Halloumi	\$23.99
Chicken Bacon Souvlaki	\$23.99
Octopus	\$26.99
Mic Chicken and Pork	\$28.99

**Before placing order please inform your server if a person in your party has a food allergy.**

## Salads

Horiatiki	\$17.99
Tomatoes, Cucumbers, onions, Olives, Green Peppers, Capers, Feta Cheese, Oregano, Topped with Evoo	
Garden	\$12.99
Lettuce, Tomatoes, Cucumbers, Olives, Carrots, Red Cabbage, pepperoncini	
Caesar	\$14.99
Crispy Romaine Lettuce, homemade Croutons and Asiago Cheese.	
Spinach	\$17.99
Fresh Spinach, Tomatoes, Bacon, Egg, Cucumbe	
Pomegranate Explosion	\$17.99
Mix Greens, Caramelized Pecans, Goat Cheese, Apples, Pomegranate, Topped with Balsamic Glaze	
Fall Harvest	\$17.99
Spinach, Quinoa, Roasted Squash, Goat Cheese, Cranberries and Walnuts, Topped with Evoo and Balsamic Glaze	
Add to all salads	
Mix Chicken and Pork Gyro	\$5.99
Chicken Gyro	\$5.99
Pork Gyro	\$5.99

## Rice Bowls

Chicken	\$19.99
Rice Pilaf, Chicken Gyro, Tirokafteri Sauce, Tomatoes, Cucumbers, Olives.	
Pork	\$19.99
Rice Pilaf, Pork Gyro, Tzatziki Sauce, Tomatoes, Cucumbers, Feta Cheese	
Mix Chicken & Pork	\$19.99
Rice Pilaf, Mix Chicken/Pork Gyro, Eat Greek Sauce, Tomatoes, Cucumbers, Olives, Feta Cheese	

# Eat Greek Gyros

215 Elm Street Somerville, MA

## Sides

Tuccini Chips	\$9.90
Classic French Fries	\$8.50
Mediterranean Fries	\$12.25
French Fries topped with Virgin Herb Olive Oil, Mixed with Feta and Graviera Cheese.	
Tirokafteri Sauce	\$7.90
Spicy Cheese. Served with warm pita	
Tzatziki Sauce	\$7.90
Served with warm pita	
Eat Greek Sauce	\$7.90
Served with warm pita	

## Power Bowls

Mediterranean	\$18.99
Tri-Color Quinoa, Olives, Onions, Tomatoes, Cucumbers, Feta Cheese, Tzatziki Sauce Topped with mix Chicken and Pork Gyro	
Mykonos	\$18.99
Tri-Color quinoa, Avocado, Grilled Shrimp, Yogurt, Cranberries, Topped with Evoo	
Paros	\$19.99
Tri-Color quinoa, Grilled Octopus, Tomatoes, Cucumbers, Tirokafteri Sauce	
Santorini	\$20.99
Halloumi Cheese, Cucumbers, Tomatoes, Grilled Zucchini and Tzatziki Sauce Over Tri-Color quinoa.	



## Desserts

Loukoumades Traditional	\$11.90
(with Greek honey and cinnamon)	

Follow us on social media:  
Instagram: @eatgreekboston





## Eat Greek Gyros

215 Elm Street Somerville, MA

### Beer

<b>Pacifico</b> 12 oz 4.5% ABV	\$8.00
<b>Corona</b> 12 oz 4.6% ABV	\$9.00
<b>Blue Moon</b> 12 oz 5.4% ABV	\$7.00
<b>Bud Light</b> 12 oz 4.2% ABV	\$7.00
<b>White Claw</b> 12 oz 5% ABV	\$8.00

### Wine

<b>Red</b> Sutter Home Cab 187 ml 12.9%	\$10.00
<b>White</b> Sutter Home Pinot 187 ml 10%	\$10.00
<b>Prosecco</b> LaMarca 187 ml 11%	\$12.00
<b>Rose</b> Capriccio Rose 187 ml 13.9%	\$10.00

### Cocktails

<b>Zeus's Thunderbolt</b> Ouzu, lemon juice and ginger beer. Garnished with a lemon twist.	\$14.00
<b>Athena's Martini</b> A classic martini with vermouth, and a splash of Greek olive juice.	\$14.00
<b>Poseidon's Blue Wave</b> Blue curacao, coconut rum, pineapple juice and a splash of lime juice.	\$14.00
<b>Apollo's Sunrise</b> Mastiha, grapefruit juice, elderflower tonic and grenadine.	\$14.00
<b>Mediterranean Margarita</b> Tequila, fresh lime juice and mastiha.	\$14.00



# LICENSING COMMISSION LICENSE APPLICATION

City of Somerville, Commonwealth of Massachusetts

Application #: ALM24-000023

File #: 19-012855

**Business Name:** The Independent

**Amendment Type:** Altering Premises or Outdoor Seating

**Location:** 75 UNION SQ

---

## APPLICANT

**Company Name:** The Independent

**Business Address:**

75 Union Square

Somerville, MA 02143

**Enter your current business license #** AL17-000050

**Do you currently serve alcohol?** Yes

**ARE YOU CHANGING THE NAME OF YOUR BUSINESS?** No

**ARE YOU CHANGING YOUR MANAGER?** No

**ARE YOU TRANSFERRING/ISSUING/PLEDGING STOCK, OR  
ARE YOU CHANGING DIRECTORS/OFFICERS/PARTNERS  
/TRUSTEES?** No

**ARE YOU ALTERING YOUR EXISTING PREMISES OR  
OUTDOOR SEATING? SELECT YES TO INLCUDE OUTDOOR  
SEATING FOR LICENSE** Yes

**Are you changing your indoor premises?** No

**Are you changing your outdoor premises?** Yes

**Parklet** Yes

**Proposed number of seats on parklet** 44

**Proposed number of tables on parklet** 13

**Are you adding any tents larger than 10 feet by 12 feet?** No

**Are you adding igloos or dome like structures?** No

**Are you adding, removing, or changing the location of any  
barriers or perimeters around the outdoor seating?** On public property

**Are you adding any heating elements?** No

**Will you have a designated dog area?** No

**Do you operate an inn?** No

**Describe your outreach to the Ward Alderman and  
neighborhood** n/a

**ARE YOU ADDING, OR ENDING, THE SERVICE OF  
CORDIALS AND LIQUEURS?** No

**ARE YOU CHANGING YOUR HOURS OF OPERATION?** No

**ARE YOU CHANGING YOUR ENTERTAINMENT?** No

<b>Total Devices indoors</b>	0
<b>Total Devices Outdoors</b>	0.0
<b>Have you ever received a Notice of Violation?</b>	No
<b>almln the last 5 years, have you been found guilty, liable, or responsible, in any judicial or administrative proceeding, for any violation of the City Wage Theft Ordinance or any State or Federal laws or regulations regulating the payment of wages?</b>	No
<b><a href="http://www.somervillema.gov/Documents/149/WAGE%20THEFT%20ORDINANCE.pdf">http://www.somervillema.gov/Documents/149/WAGE%20THEFT%20ORDINANCE.pdf</a></b>	
<b>You must read and accept the above stated terms &amp; conditions</b>	Yes
<b>You must read and accept the above stated terms &amp; conditions</b>	Yes

**Approved By:**

**Albert Bargoot, Approved**  
**CS Traffic and Parking, Approved**  
**Niki Green, Approved with Conditions**

RECORD COMMENT: NG240404 This application includes a liquor license and non-contiguous premises that require ABCC approval before implementation.

N/A: NG240404 submit scaled site plan prepared and certified by a design professional. See Outdoor Seating License Process & Appendices for additional requirements at [www.somervillema.gov/departments/licensing-commission](http://www.somervillema.gov/departments/licensing-commission). Site plan needs to be certified /stamped by the design professional.

N/A: NG240404 Provide photo, rendering, dimensions and/or manufacturer's documentation of all proposed furniture, barriers, fencing, tables, chairs, etc. If providing only photos, overall dimensions of each item must be provided.

N/A: NG240404 Provide toilet capacity calculations, including both existing indoor seating and proposed outdoor seating counts, prepared and certified by a design professional or plumbing engineer currently licensed in Massachusetts (248 CMR 10.10 & 521 CMR 30.00). Toilet capacity calculations are reviewed by the Inspectional Services Department (ISD).

N/A: NG240404 Provide at least one accessible table or 10% of total outdoor seating in each license area, whichever is greater. Accessible tables shall be distributed by size and location throughout the license area (521 CMR 17.2). Revise plan to show.

N/A: NG240404 Parklet Seating located on a constructed platforms shall be level (2% maximum slope in any direction), stable, firm and slip resistant, and connects to the sidewalk with a bridge plate that spans over the curb and provides a level change of less than ¼" (521 CMR 20). Provide manufacture's spec sheet for the bridge plate that will be installed on the entrance of the parklet. Minimum requirements are ENTRANCE'x2' with a level change of less than ¼ inches (521 CMR 20). Revise plan to show location of bridge plate.

N/A: NG240404 Parklet Seating shall include a traffic control facing oncoming traffic. Traffic barriers may include Jersey Barriers, water-filled barriers, etc. The design of the barrier is part of the license approval. Revise plans.

N/A: NG240404 Parklet Seating shall include reflective tape or reflective markers to the traffic facing sides of the Parklet structure or railings. Revise plans.

APPROVAL CONDITION: Engineering approval is conditional on the designed size, shape, and occupancy of parklet structure remaining the same as shown in plans, minus area shown in markup. If parklet design, occupancy, or ownership changes, applicant will need to submit revised documentation satisfying all permit requirements at time of submittal.

**Timothy Mitsakis, Approved**

Engineering Approval  
with Conditions  
NIKI Green  
04/04/2024

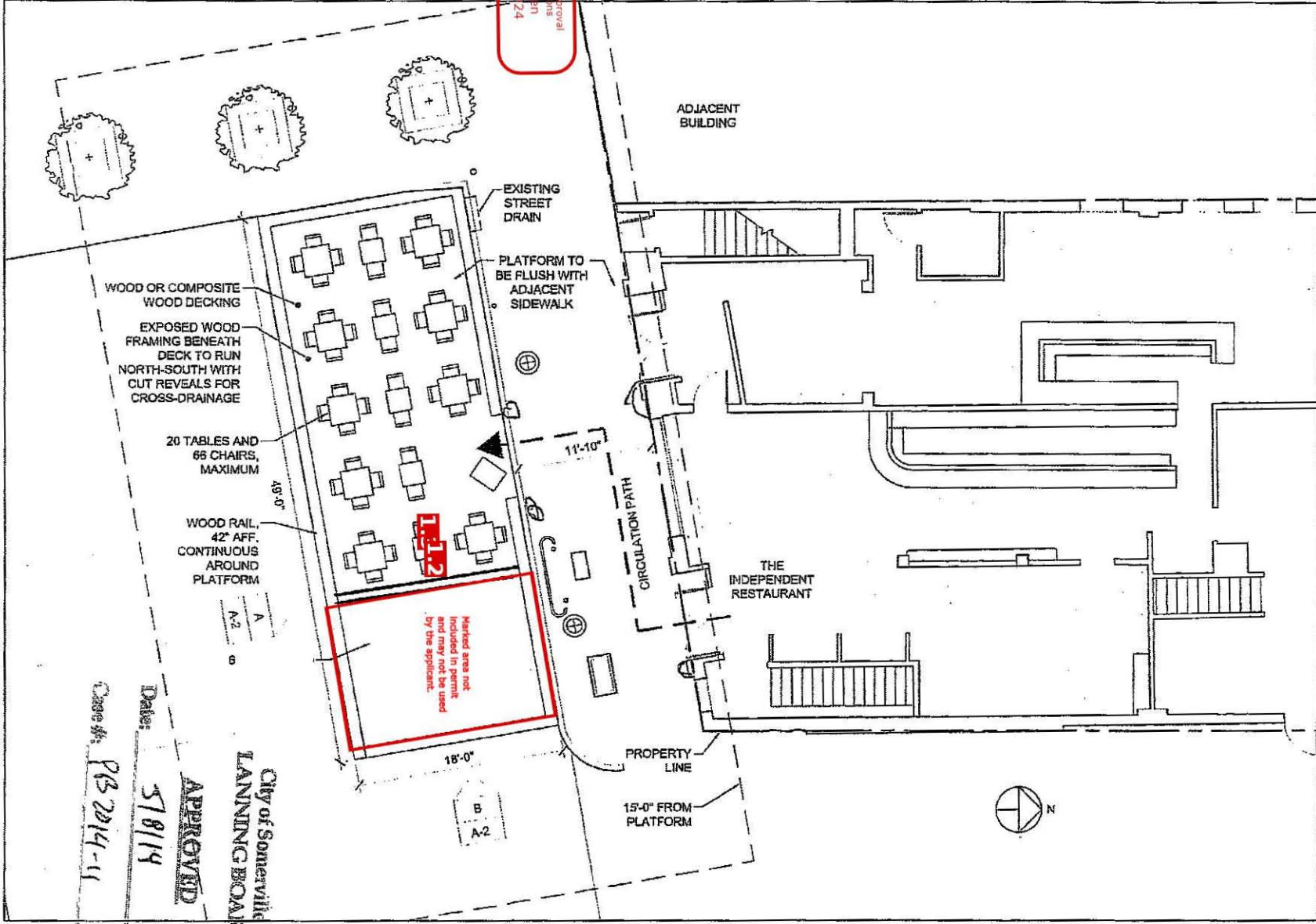

Project  
**RENOVATIONS TO INDEPENDENT PARKLET**  
75 UNION SQUARE

Title  
**PROPOSED SITE PLAN**

**DAVIS** 2104 Elm St., Somerville, MA 02142  
SQUARE 617.628.5700  
ARCHITECTS www.davisarchitects.com

City of Somerville  
LANDING BOARD

Designed  
Checked  
Project No. 10009.00  
Scale 1/8" = 1'-0"  
Date 3/26/12

Drawing No.  
**A-1**

Case #: P13 2014-11  
Date: 5/18/14

**APPROVED**  
City of Somerville  
LANDING BOARD

A-2

Drawing No.

Designed

Checked

Project No.

Date

3/26/12

Scale

1/4" = 1'-0"

031818009 - 225 Elm Restaurant-Independent Parklet



DAVIS  
SQUARE  
ARCHITECTS

2104 Elm St, Somerville, MA 02142

617.628.5700

www.davisquarearchitects.com

PROPOSED ELEVATIONS

T1B

Project  
RENOVATIONS TO  
INDEPENDENT PARKLET  
76 UNION SQUARE

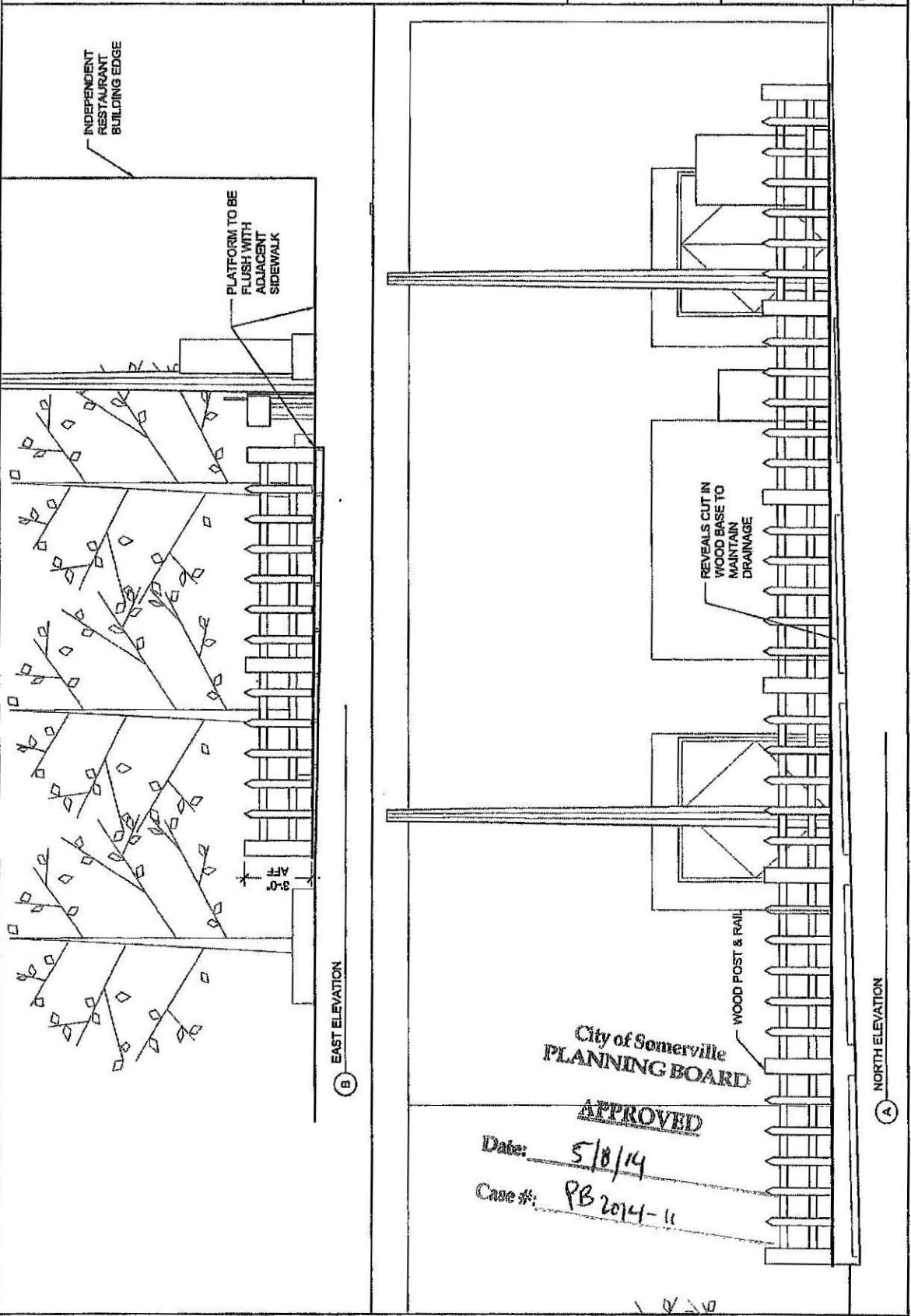

City of Somerville  
PLANNING BOARD

APPROVED

Date: 5/8/14

Case #: PB 2014-11

Picture of the Patio at The Independent Summer 2013

