

DO NOT SCALE FROM THIS PRINT

-XX	-S, -D, -T, -P	-S-RA, -P-RA	-D-RA	-T-RA
-01	C-08-1-XXX	N/A	N/A	N/A
-02	C-08-2-XXX	C-08-2-XXX	C-08-2-XXX C-08-3-XXX	C-08-2-XXX C-08-3-XXX C-08-5-XXX
-03	C-08-3-XXX	C-08-3-XXX	C-08-3-XXX C-08-5-XXX	N/A
-04	C-08-5-XXX	C-08-5-XXX	N/A	N/A
-06	C-08-6-XXX	N/A	N/A	N/A
-21	C-17-1-XXX	N/A	N/A	N/A
-22	C-17-2-XXX	C-17-2-XXX	C-17-2-XXX C-17-3-XXX	C-17-2-XXX C-17-3-XXX C-17-5-XXX
-23	C-17-3-XXX	C-17-3-XXX	C-17-3-XXX C-17-5-XXX	N/A
-24	C-17-5-XXX	C-17-5-XXX	N/A	N/A

ROW OPTION	BODY
-S	SSW-XX-S
-D	SSW-XX-D
-D-N	NSW-XX-D-N-XX
-T	SSW-XX-T
-P	SSW-XX-P
-Q	SSW-XX-T

SSW-1XX-XX-XXX-X-XX-XXX-XX

**No. OF POSITIONS**  
-01 THRU -50  
(-P OPTION: 36 POS MAX)

**LEAD STYLE**  
(SEE TABLE 1)  
-01 THRU -06 (STD. INS. FORCE)  
-21 THRU -24 (LOW INS. FORCE)

**OPTION**  
-LL: LOCKING LEAD  
(SEE FIG 4, SHT 2)  
(N/A IN SINGLE ROW,  
1 & 2 POSITION)

**POLARIZING OPTION**  
INDICATE POS, SEE FIG 3, SHT 3

**OPTION**  
-RA: RIGHT ANGLE (SEE FIG 2, SHT 2)  
(STYLE -01 & -21 N/A)  
-N: NOTCH (SEE FIG 6, SHT 3)  
(ONLY AVAILABLE IN -D ROW)  
(ONLY AVAILABLE IN 5, 7, 8, 10, 12,  
13, 15, 17, 20, 25, 32, 36 POSITIONS)  
(USE NSW-XX-D-N-XX BODY,  
SEE TABLE 6)

**PLATING SPECIFICATION**

-G: 20µ" GOLD IN CONTACT AREA,  
3µ" GOLD ON TAIL  
-T: MATTE TIN CONTACT AND TAIL  
(CONTACT -21 THRU -24 N/A)  
-S: 30µ" SELECTIVE GOLD IN CONTACT AREA,  
MATTE TIN ON TAIL  
-H: 30µ" HEAVY GOLD IN CONTACT AREA,  
3µ" GOLD ON TAIL  
-E: 50µ" EXTRA HEAVY GOLD IN CONTACT AREA,  
3µ" GOLD ON TAIL  
(CONTACT -01 & -02 STRAIGHT ONLY)  
-F: 3µ" FLASH SELECTIVE GOLD IN CONTACT AREA,  
MATTE TIN ON TAIL  
-STL: 30µ" SELECTIVE GOLD IN CONTACT AREA,  
TIN/LEAD (90/10 ± 5%) TAIL  
-TL: TIN/LEAD (90/10 ± 5%) CONTACT AND TAIL  
(AVAILABLE ONLY ON LEAD STYLES -01)  
-TM: MATTE TIN CONTACT AND TAIL (CONTACT -21 THRU -24 N/A)  
-SM: 30µ" SELECTIVE GOLD IN CONTACT AREA,  
MATTE TIN ON TAIL  
-FM: 3µ" FLASH GOLD SELECTIVE IN CONTACT AREA,  
MATTE TIN ON TAIL  
-L: 10µ" LIGHT SELECTIVE GOLD IN CONTACT AREA,  
MATTE TIN ON TAIL

**ROW SPECIFICATION**

-S: SINGLE  
-D: DOUBLE  
-T: TRIPLE  
-P: SINGLE  
-Q: TRIPLE WITH ONLY OUTER 2 ROWS  
FILLED

LEAD STYLE	"B"	"G"	"C" REF		
	-S(-RA), -D, -T	-D, -T	-S-RA	-D-RA	-T-RA
-01, -21	.104 [2.64]	.005 [.13]	N/A	N/A	N/A
-02, -22	.194 [4.93]	.005 [.13]	.100 [2.54]	.100 [2.54]	.100 [2.54]
-03, -23	.394 [10.01]	+ .010 / - .012 [+ .25 / - .31]	.300 [7.62]	.300 [7.62]	N/A
-04, -24	.584 [14.83]	+ .010 / - .012 [+ .25 / - .31]	.490 [12.45]	N/A	N/A
-06	.124 [3.15]	.005 [.13]	N/A	N/A	N/A

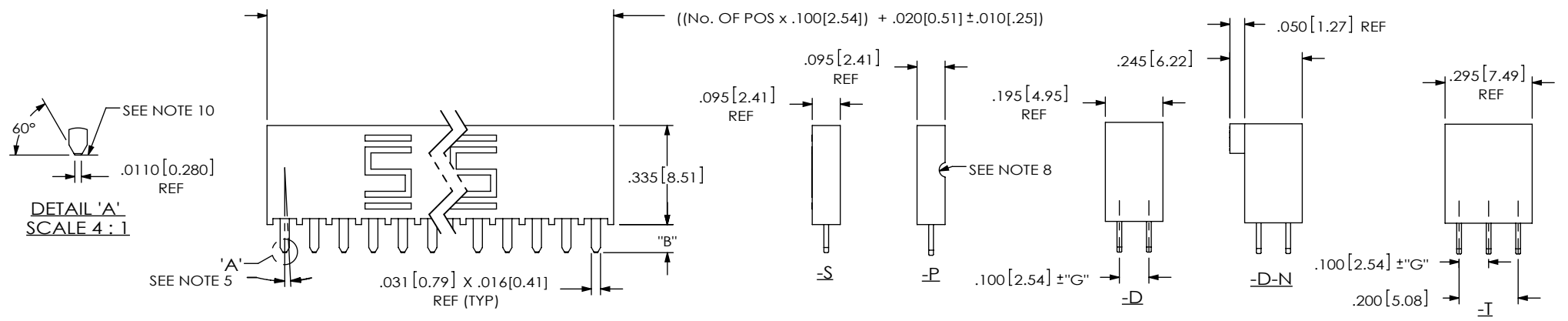

- NOTES:
1. Ⓞ REPRESENTS A CRITICAL DIMENSION.
  2. MAXIMUM CUT FLASH: .015[.38] WITH NO FLASH BELOW STANDOFFS OR IN CONTACT HOLES.
  3. MINIMUM CONTACT PUSHOUT FORCE: 1.5 LBS.
  4. MAXIMUM ALLOWABLE BOW: .003[.08] INCH/INCH.
  5. MAXIMUM ALLOWABLE SWAY: 2° (TYP) FOR HAND FILL & 1° (TYP) FOR MACHINE FILL.
  6. MAXIMUM ALLOWABLE VARIATION BETWEEN ROWS: .010[.25].
  7. "END WALLS" AFTER CUTTING SHOULD BE .020±.003 [.51±.08].
  8. NOTCH ON -P-RA & -D-RA-N OPTIONS TO BE ORIENTED AS SHOWN.
  9. SHEAR LOCATION TO BE WITHIN .001[.03] OF THE BREAK OFF CENTER LOCATION.
  10. SHEAR LOCATION TO BE WITHIN .001[.03] OF THE BREAK OFF CENTER LOCATION FOR MACHINE FILL.
  11. LEAD STYLE X2 (SINGLE AND DOUBLE) -RA's TO BE LAYER PACKAGED. ALL OTHER -RA LEAD STYLES: UNDER 5 POSITION TO BE LAYER PACKAGED, 5 AND UP TO BE PACKAGED IN TUBES.

UNLESS OTHERWISE SPECIFIED, DIMENSIONS ARE IN INCHES.

TOLERANCES ARE:

DECIMALS	ANGLES
.XX: ±.01 [.3]	2°
.XXX: ±.005 [.13]	

**PROPRIETARY NOTE**  
THIS DOCUMENT CONTAINS CONFIDENTIAL AND PROPRIETARY INFORMATION AND ALL DESIGN, MANUFACTURING, REPRODUCTION, USE, PATENT RIGHTS AND SALES RIGHTS ARE EXPRESSLY RESERVED BY SAMTEC, INC. THIS DOCUMENT SHALL NOT BE DISCLOSED, IN WHOLE OR PART, TO ANY UNAUTHORIZED PERSON OR ENTITY NOR REPRODUCED, TRANSFERRED OR INCORPORATED IN ANY OTHER PROJECT IN ANY MANNER WITHOUT THE EXPRESS WRITTEN CONSENT OF SAMTEC, INC.

**MATERIAL:**  
INSULATOR: DO NOT SCALE DRAWING  
-S, -D, -D-N: VECTRA E130I, COLOR: BLACK UL94 VO  
-P, -T: PCTI, COLOR: BLACK UL94 VO  
CONTACT: PHOSPHOR BRONZE, SPRING TEMPER ALLOY 511 OR 510  
(TENSILE STRENGTH 90-100 KSI)  
(YIELD STRENGTH @ 2% OFFSET 88-98 KSI)  
PER MIL-8-13501  
THICKNESS: .0160±.001 [0.635±0.03]

SHEET SCALE: 2:1

**samtec**

520 PARK EAST BLVD, NEW ALBANY, IN 47150  
PHONE: 812-944-6733 FAX: 812-948-5047  
e-Mail: info@SAMTEC.com code 55322

DESCRIPTION:  
ASSEMBLY, SOCKET STRIP .016 X .031 TAIL

DWG. NO.  
SSW-1XX-XX-XXX-X-XX-XXX-XX

BY: PURVIS 06/12/1987 SHEET 1 OF 3

TABLE 3			
IN-PROCESS	"D"	"E"	"F"
SSW-1XX-X2-X-D-RA	.194 [4.93]	.394 [10.01]	-----
SSW-1XX-03-X-D-RA	.394 [10.01]	.594 [15.09]	-----
SSW-1XX-02-X-T-RA	.194 [4.93]	.394 [10.01]	.594 [15.09]

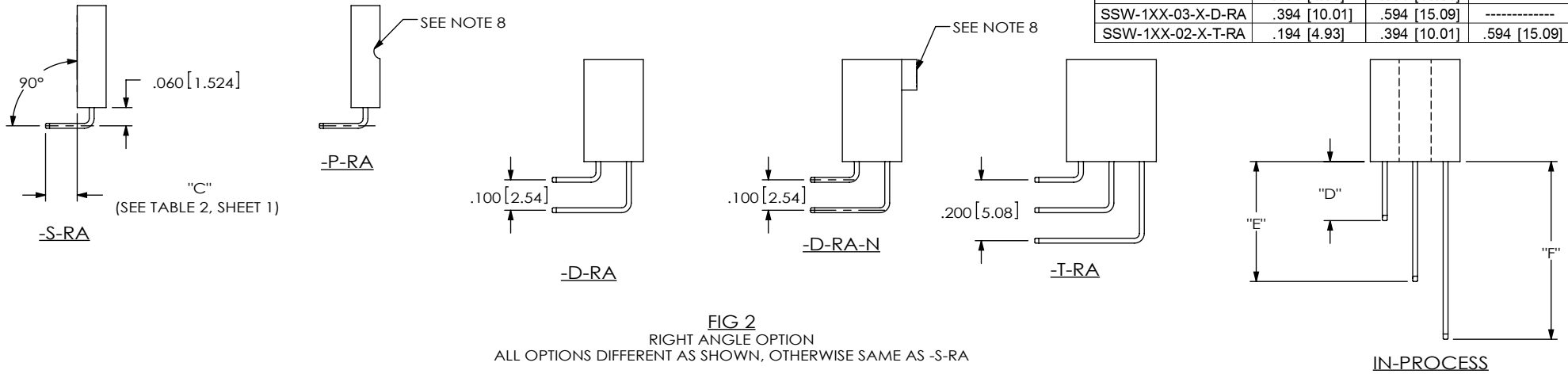

FIG 2  
RIGHT ANGLE OPTION  
ALL OPTIONS DIFFERENT AS SHOWN, OTHERWISE SAME AS -S-RA

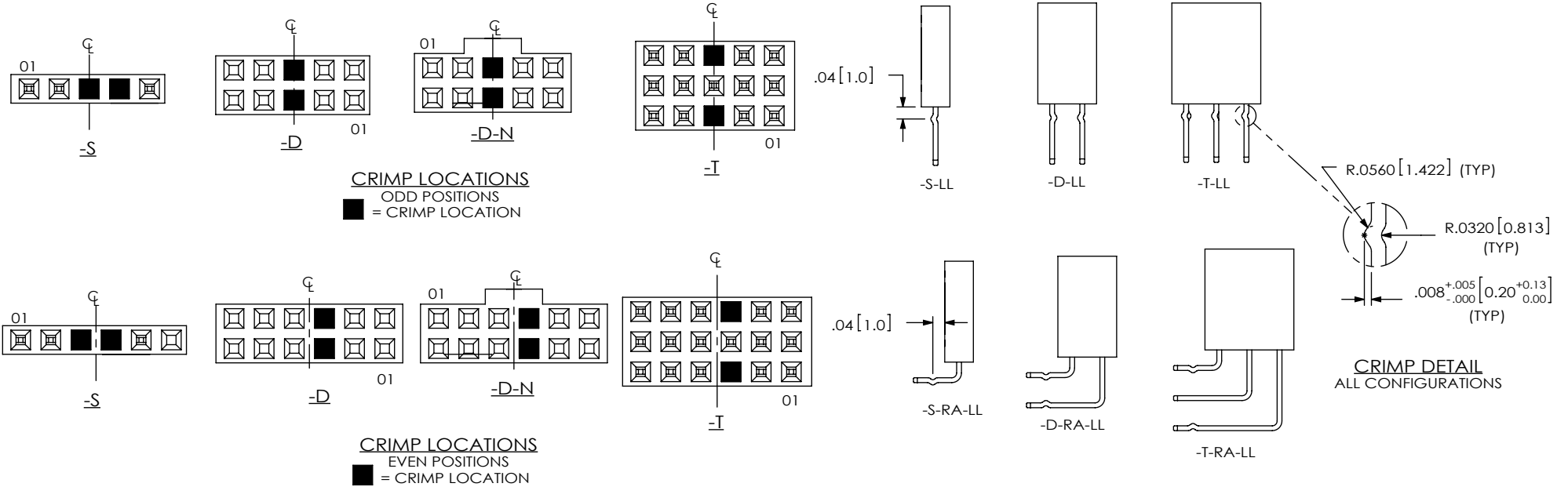

FIG 4  
LOCKING LEAD OPTION  
ALL OPTIONS SAME AS -S-XX-LL  
UNLESS OTHERWISE SHOWN

**PROPRIETARY NOTE**  
THIS DOCUMENT CONTAINS CONFIDENTIAL AND PROPRIETARY INFORMATION AND ALL DESIGN, MANUFACTURING, REPRODUCTION, USE, PATENT RIGHTS AND SALES RIGHTS ARE EXPRESSLY RESERVED BY SAMTEC, INC. THIS DOCUMENT SHALL NOT BE DISCLOSED, IN WHOLE OR PART, TO ANY UNAUTHORIZED PERSON OR ENTITY NOR REPRODUCED, TRANSFERRED OR INCORPORATED IN ANY OTHER PROJECT IN ANY MANNER WITHOUT THE EXPRESS WRITTEN CONSENT OF SAMTEC, INC.

**samtec**  
520 PARK EAST BLVD, NEW ALBANY, IN 47150  
PHONE: 812-944-6733 FAX: 812-948-5047  
e-Mail info@SAMTEC.com code 55322

DO NOT SCALE DRAWING  
SHEET SCALE: 2:1

DESCRIPTION:  
ASSEMBLY, SOCKET STRIP .016 X .031 TAIL  
DWG. NO.  
SSW-1XX-XX-XXX-X-XX-XXX-XX  
BY: PURVIS 06/12/1987 SHEET 2 OF 3

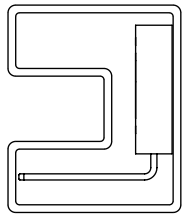

SSW-1XX-03-XXX-S-RA  
SSW-1XX-23-XXX-S-RA

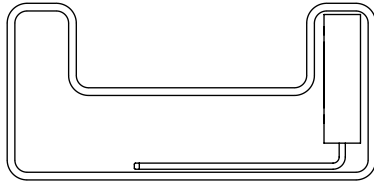

SSW-1XX-04-XXX-S-RA  
SSW-1XX-24-XXX-S-RA

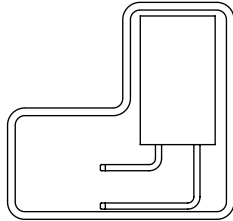

SSW-1XX-03-XXX-D-RA  
SSW-1XX-23-XXX-D-RA

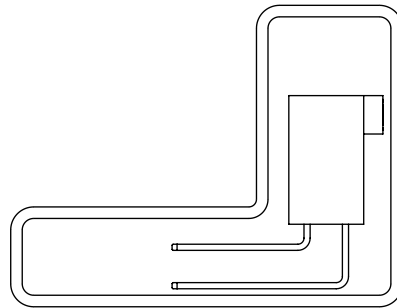

SSW-1XX-03-XXX-D-RA-N  
SSW-1XX-23-XXX-D-RA-N

TABLE 5 TUBE SPECIFICATION		
PART NUMBER	TUBE	PLUG
SSW-1XX-03-XXX-S-RA SSW-1XX-23-XXX-S-RA	PT-3-24-01-01	TP-03
SSW-1XX-04-XXX-S-RA SSW-1XX-24-XXX-S-RA	PT-1-24-01-34	TP-03
SSW-1XX-03-XXX-D-RA SSW-1XX-23-XXX-D-RA	PT-1-24-06-40	TP-07
SSW-1XX-03-XXX-D-RA-N SSW-1XX-23-XXX-D-RA-N	ASP-90341-01-S	TP-07
SSW-1XX-02-XXX-T-RA SSW-1XX-02-XXX-Q-RA	PT-1-24-04-40	TP-07

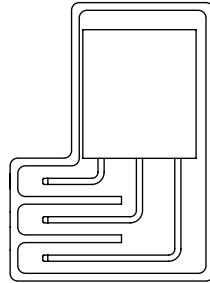

SSW-1XX-02-XXX-T-RA  
SSW-1XX-02-XXX-Q-RA

FIG 5  
PACKAGING VIEWS  
(SEE NOTE 11)

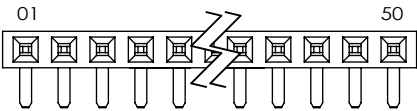

-S, -P, -S-RA & -P-RA

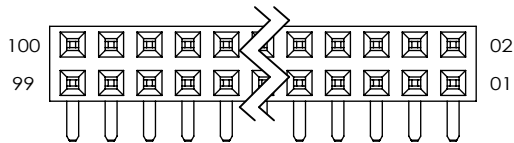

-D, -D-RA

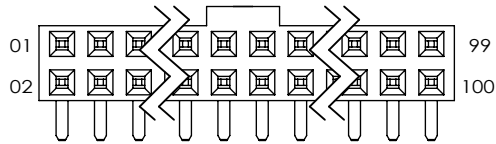

-D-N, -D-RA-N

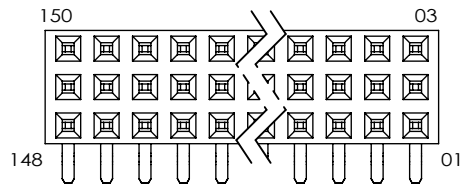

-T, -Q, -T-RA & -Q-RA

FIG 3

POLARIZATION LOCATION

(INSERT PK-06-N INTO SPECIFIED POSITION & BREAK OFF TAB)  
(-RA OPTION SHOWN FOR ORIENTATION PURPOSE ONLY)

TABLE 6	
POS PER ROW	NSW-XX-D-N-XX
5	NSW-47-D-N-05
7	NSW-47-D-N-07
8	NSW-44-D-N-08
10	NSW-43-D-N-10
12	NSW-38-D-N-12
13	NSW-41-D-N-13
15	NSW-47-D-N-15
17	NSW-35-D-N-17
20	NSW-20-D-N
25	NSW-25-D-N
32	NSW-32-D-N
36	NSW-36-D-N

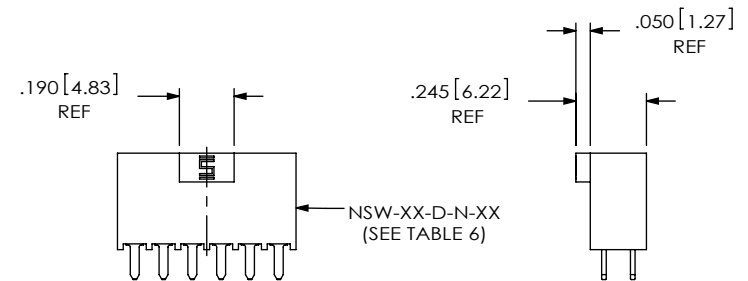

FIG 6  
NOTCH OPTION  
DIFFERENT AS SHOWN, OTHERWISE SAME AS FIG 1

**PROPRIETARY NOTE**  
THIS DOCUMENT CONTAINS CONFIDENTIAL AND PROPRIETARY INFORMATION AND ALL DESIGN, MANUFACTURING, REPRODUCTION, USE, PATENT RIGHTS AND SALES RIGHTS ARE EXPRESSLY RESERVED BY SAMTEC, INC. THIS DOCUMENT SHALL NOT BE DISCLOSED, IN WHOLE OR PART, TO ANY UNAUTHORIZED PERSON OR ENTITY NOR REPRODUCED, TRANSFERRED OR INCORPORATED IN ANY OTHER PROJECT IN ANY MANNER WITHOUT THE EXPRESS WRITTEN CONSENT OF SAMTEC, INC.

DO NOT SCALE DRAWING

SHEET SCALE: 2:1



520 PARK EAST BLVD, NEW ALBANY, IN 47150  
PHONE: 812-944-6733 FAX: 812-948-5047  
e-Mail info@SAMTEC.com code 55322

DESCRIPTION:  
ASSEMBLY, SOCKET STRIP .016 X .031 TAIL

DWG. NO.  
SSW-1XX-XX-XXX-X-XX-XXX-XX

BY: PURVIS 06/12/1987 SHEET 3 OF 3

# Mouser Electronics

Authorized Distributor

Click to View Pricing, Inventory, Delivery & Lifecycle Information:

[Samtec:](#)

[SSW-102-04-G-S-RA](#)