

GENERAL DESCRIPTION

The MC3630 is an ultra-low power, low-noise, integrated digital output 3-axis accelerometer with a feature set optimized for wearables and consumer product motion sensing. Applications include wearable consumer products, IoT devices, user interface control, gaming motion input, electronic compass tilt compensation for cell phones, game controllers, remote controls and portable media products.

Low noise and low power are inherent in the monolithic fabrication approach, where the MEMS accelerometer is integrated in a single-chip with the electronics integrated circuit.

In the MC3630 the internal sample rate can be set from 14 to 1300 samples / second. Specific tap or sample acquisition conditions can trigger an interrupt to a remote MCU. Alternatively, the device supports the reading of sample and event status via polling.

FEATURES

Range, Sampling & Power

- $\pm 2, 4, 8, 12$ or $16g$ ranges
- 8, 10 or 12-bit resolution with FIFO
 - 14-bit single samples
- Sample rate 14 - 1300 samples/sec
 - Sample trigger via internal oscillator, clock pin or software command
- Sniff and Wake modes
 - $0.4 \mu A$ Sniff current @ 6Hz
 - Separate or combined sniff/wake
- Ultra-Low Power with 32 sample FIFO
 - $0.9 \mu A$ typical current @ 25Hz
 - $1.6 \mu A$ typical current @ 50Hz
 - $2.8 \mu A$ typical current @ 100Hz
 - $36 \mu A$ typical current @ 1300Hz

Simple System Integration

- I2C interface, up to 1 MHz
- SPI Interface, up to 8 MHz
- $2.0 \times 2.0 \times 0.94$ mm 12-pin package
- Single-chip 3D silicon MEMS
- Low noise to $2.3mgRMS$
- ROHS Compliant

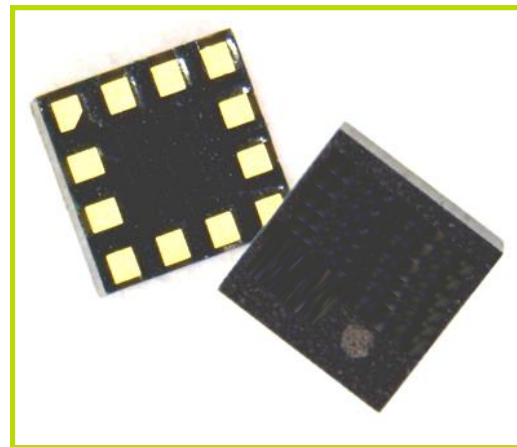

TABLE OF CONTENTS

- 1 Order Information..... 5
- 2 Functional Block Diagram 6
- 3 Packaging and Pin Description 7
 - 3.1 Package Outline..... 7
 - 3.2 Package Orientation..... 8
 - 3.3 Pin Description 9
 - 3.4 Typical Application Circuits 10
 - 3.5 Tape and Reel 13
 - 3.6 Soldering Profile..... 15
 - 3.7 Shipping and Handling Guidelines 15
 - 3.8 Moisture Sensitivity Level Control 15
- 4 Specifications..... 16
 - 4.1 Absolute Maximum Ratings..... 16
 - 4.2 Sensor Characteristics 17
 - 4.3 Electrical and Timing Characteristics..... 18
 - 4.3.1 Electrical Power and Internal Characteristics 18
 - 4.3.2 Electrical Characteristics 19
 - 4.3.3 I2C Timing Characteristics..... 20
 - 4.3.4 SPI Timing Characteristics..... 21
- 5 General Operation 22
 - 5.1 Sensor Sampling..... 22
 - 5.2 Offset and Gain Calibration 22
 - 5.3 Reset 22
 - 5.4 Reload 23
 - 5.5 Operational Modes..... 24
 - 5.6 Mode State Machine Flow 25
- 6 Interfaces 26
 - 6.1 SPI vs I2C Operation Modes 26
 - 6.2 I2C Physical Interface 26
 - 6.3 I2C Message Format..... 27
 - 6.4 SPI Physical Interface 27



- 6.5 SPI 3-Wire Mode..... 28
- 6.6 SPI Protocol..... 28
- 6.7 SPI Register Write Cycle - Single..... 29
- 6.8 SPI Register Write Cycle - Burst 29
- 6.9 SPI Register Read Cycle - Single..... 29
- 6.10 SPI Register Read Cycle - Burst 30
- 6.11 SPI Status Option..... 30
- 6.12 SPI High-Speed Mode..... 31
- 7 Register Interface 32
 - 7.1 Register Summary 33
 - 7.2 (0x00) Extended Status Register 1..... 35
 - 7.3 (0x01) Extended Status Register 2..... 36
 - 7.4 (0x02 – 0x07) XOUT, YOUT & ZOUT Data Output Registers..... 37
 - 7.5 (0x08) Status Register 1..... 38
 - 7.6 (0x09) Status Register 2..... 40
 - 7.7 (0x0D) Feature Register 1 42
 - 7.8 (0x0E) Feature Register 2 44
 - 7.9 (0x0F) Initialization Register 1 47
 - 7.10 (0x10) Mode Control Register 48
 - 7.11 (0x11) Rate Register 1 50
 - 7.12 (0x12) Sniff Control Register 52
 - 7.13 (0x13) Sniff Threshold Control Register 54
 - 7.14 (0x14) Sniff Configuration Register 57
 - 7.15 (0x15) Range and Resolution Control Register 59
 - 7.16 (0x16) FIFO Control Register 61
 - 7.17 (0x17) Interrupt Control Register 62
 - 7.18 (0x18) Chip ID Register..... 64
 - 7.19 (0x1A) Initialization Register 3..... 65
 - 7.20 (0x1B) Scratchpad Register 66
 - 7.21 (0x1C) Power Mode Control Register..... 67
 - 7.22 (0x20) Drive Motion X Register 69
 - 7.23 (0x21) Drive Motion Y Register 70
 - 7.24 (0x22) Drive Motion Z Register..... 71



7.25	(0x24) Reset Register	72
7.26	(0x28) Initialization Register 2	73
7.27	(0x29) Trigger Count Register/SDR configuration	74
7.28	(0x2A – 0x2B) X-Axis Offset Registers	75
7.29	(0x2C – 0x2D) Y-Axis Offset Registers	76
7.30	(0x2E – 0x2F) Z-Axis Offset Registers	77
7.31	(0x2B & 0x30) X-Axis Gain Registers.....	78
7.32	(0x2D & 0x31) Y-Axis Gain Registers.....	79
7.33	(0x2F & 0x32) Z-Axis Gain Registers	80
8	Index of Tables	81
9	Revision History	83
10	Legal.....	84



1 Order Information

Table 1. Order Information

Part Number	Resolution	Order Number	Package	Shipping
MC3630	8 to 14-bit	MC3630	VLGA-12	Tape & Reel, 5Ku

Table 2. Package Information



Row	Marking
XXYM	Device identifier and date code
CCC	Factory lot code
●	Pin 1 identifier



2 Functional Block Diagram

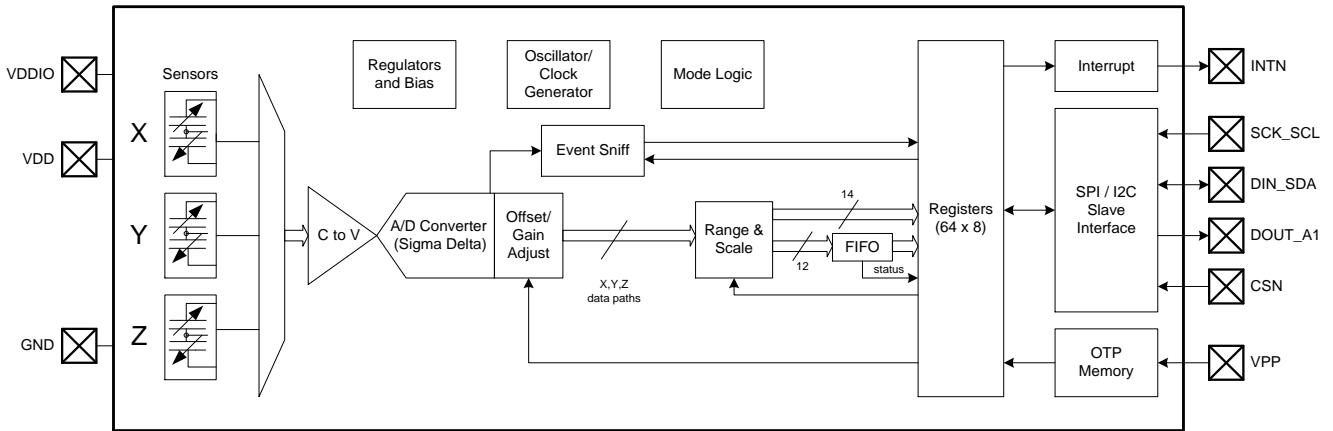

Figure 1. Block Diagram



3 Packaging and Pin Description

3.1 Package Outline

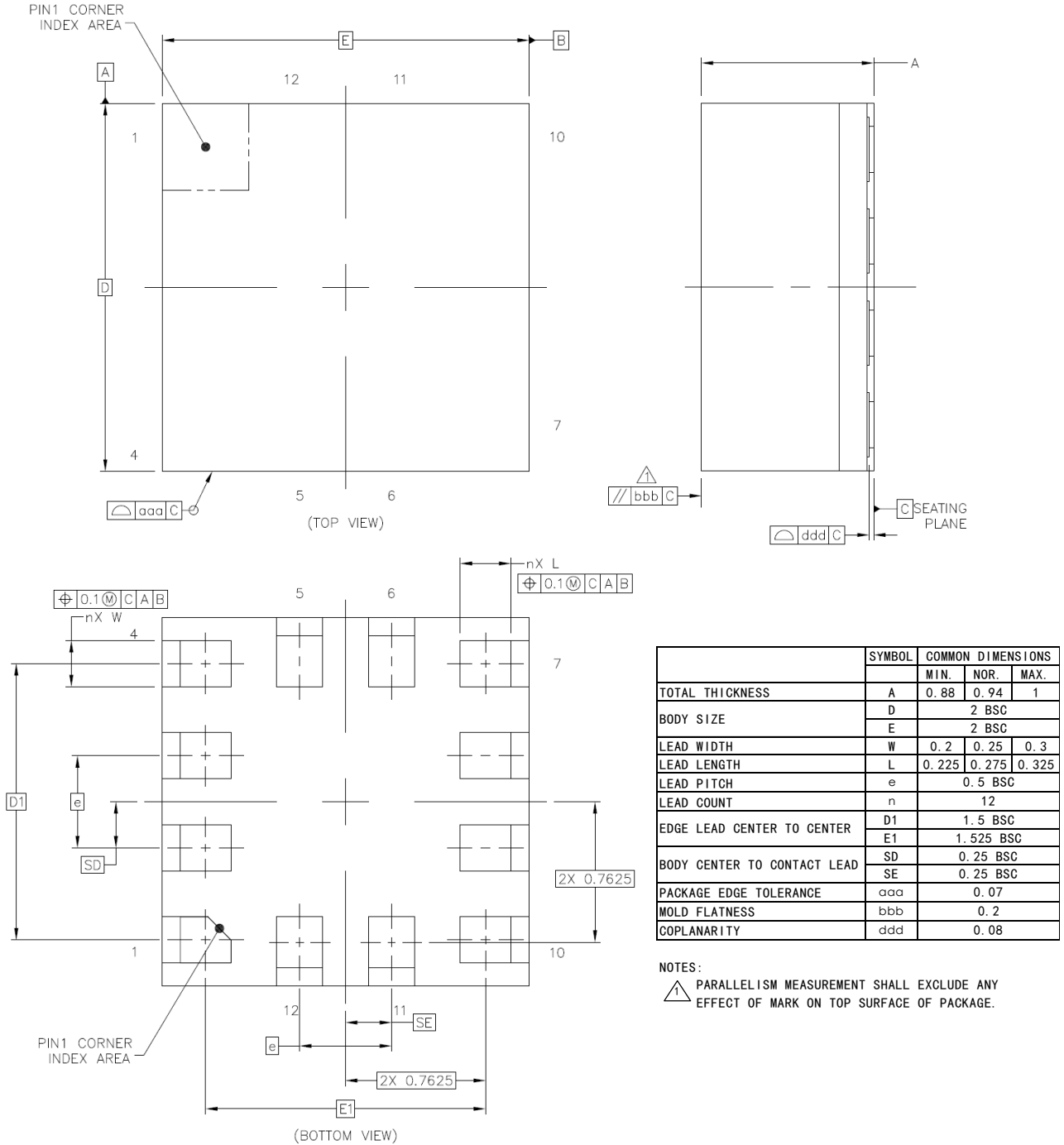

Figure 2. Package Outline and Mechanical Dimensions



3.2 Package Orientation

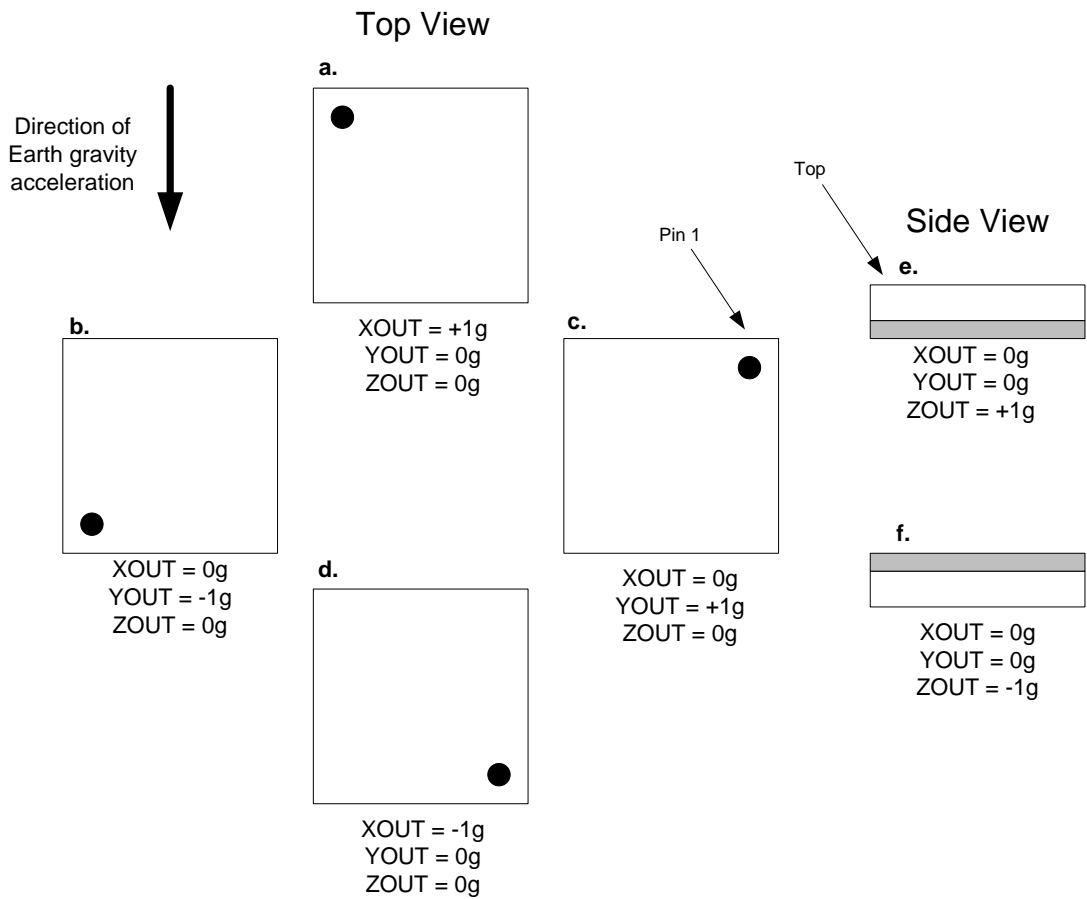

Figure 3. Package Orientation

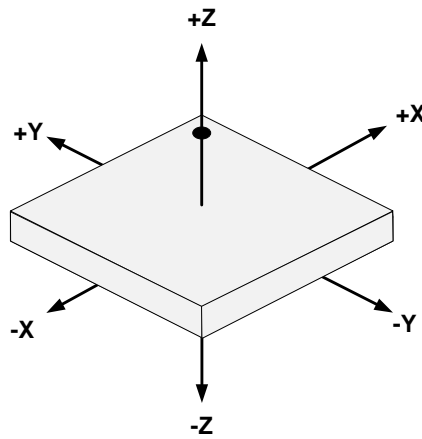

Figure 4. Package Axis Reference



3.3 Pin Description

Pin	Name	Function
1	DOUT_A1	SPI data output I2C address bit 1
2	DIN_SDA ¹	SPI data In I2C serial data input/output
3	VDDIO	Power supply for interface
4	VPP	Connect to GND
5	INTN ²	Interrupt active LOW ³
6	NC	No connect
7	VDD	Power supply for internal
8	NC	No connect
9	GND	Ground
10	CSN	SPI chip select
11	NC	No connect
12	SCK_SCL ¹	SPI Clock I2C serial clock input

Table 2. Pin Description

Notes:

- 1) When using the I2C interface, this pin requires a pull-up resistor, typically 4.7kΩ to pin VDDIO. Refer to I2C Specification for Fast-Mode devices. Higher resistance values can be used (typically done to reduce current leakage) but such applications are outside the scope of this datasheet.
- 2) This pin can be configured by software to operate either as an open-drain output or push-pull output. If set to open-drain, then it requires a pull-up resistor, typically 4.7kΩ to pin VDDIO.
- 3) INTN pin polarity is programmable.



3.4 Typical Application Circuits

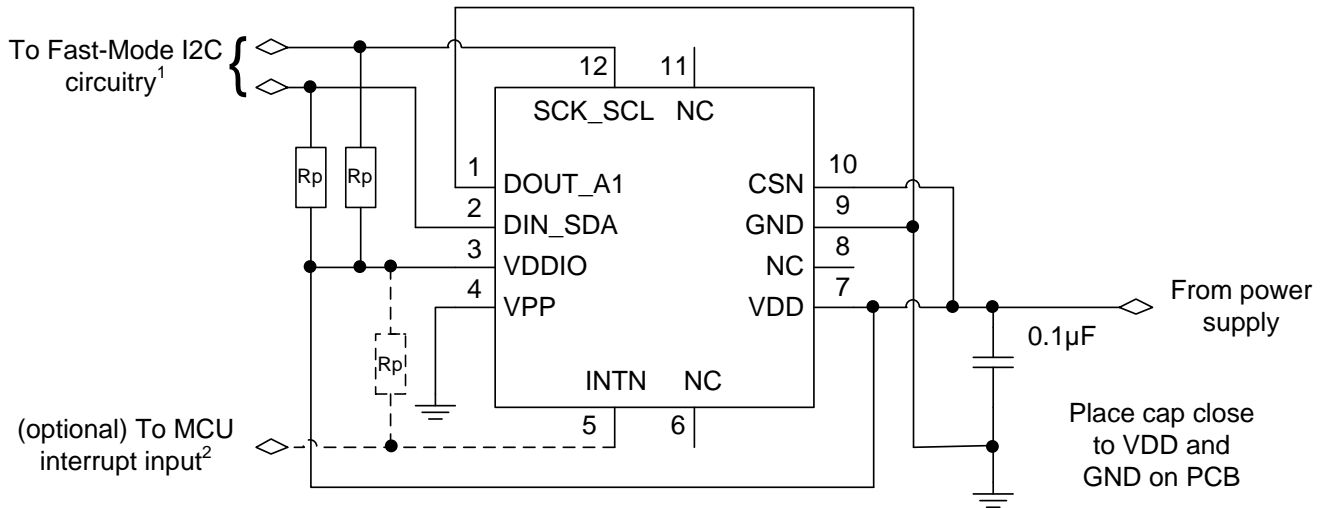

NOTE¹: Rp are typically 4.7kΩ pullup resistors to VDDIO, per I2C specification. When VDDIO is powered down, DIN_SDA and SCK_SCL will be driven low by internal ESD diodes.

NOTE²: Attach typical 4.7kΩ pullup resistor if INTN is defined as open-drain.

Figure 5. Typical I2C Application Circuit

In typical applications, the interface power supply may contain significant noise from external sources and other circuits which should be kept away from the device. Therefore, for some applications a lower-noise power supply might be desirable to power the device.



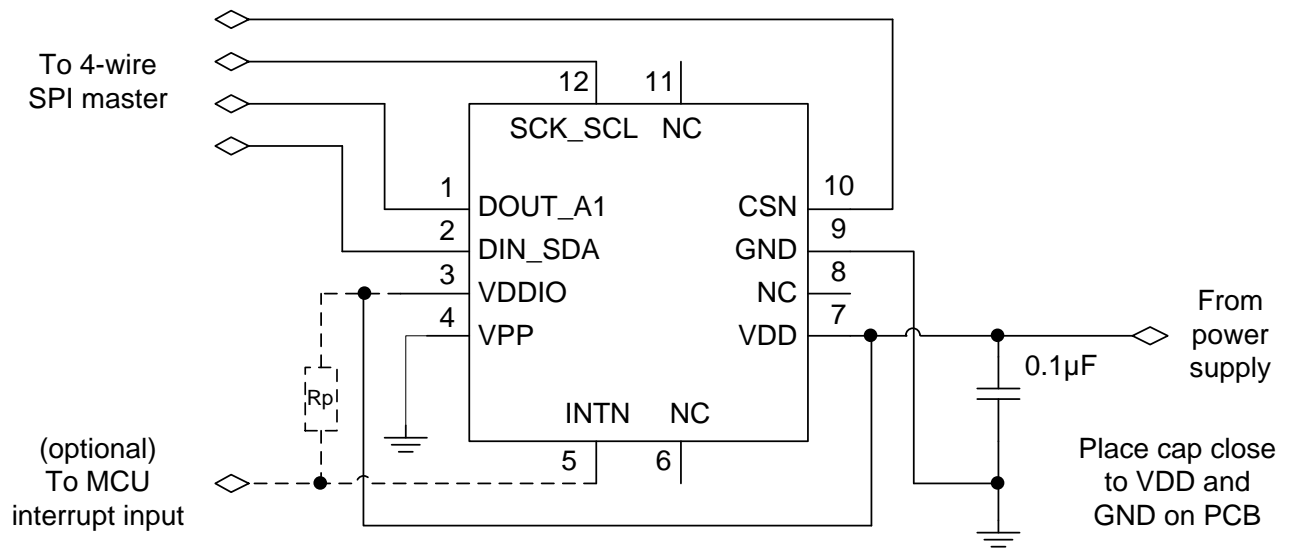

NOTE Rp: Attach typical 4.7kΩ pullup resistor if INTN is defined as open-drain.

Figure 6. Typical 4-wire SPI Application Circuit



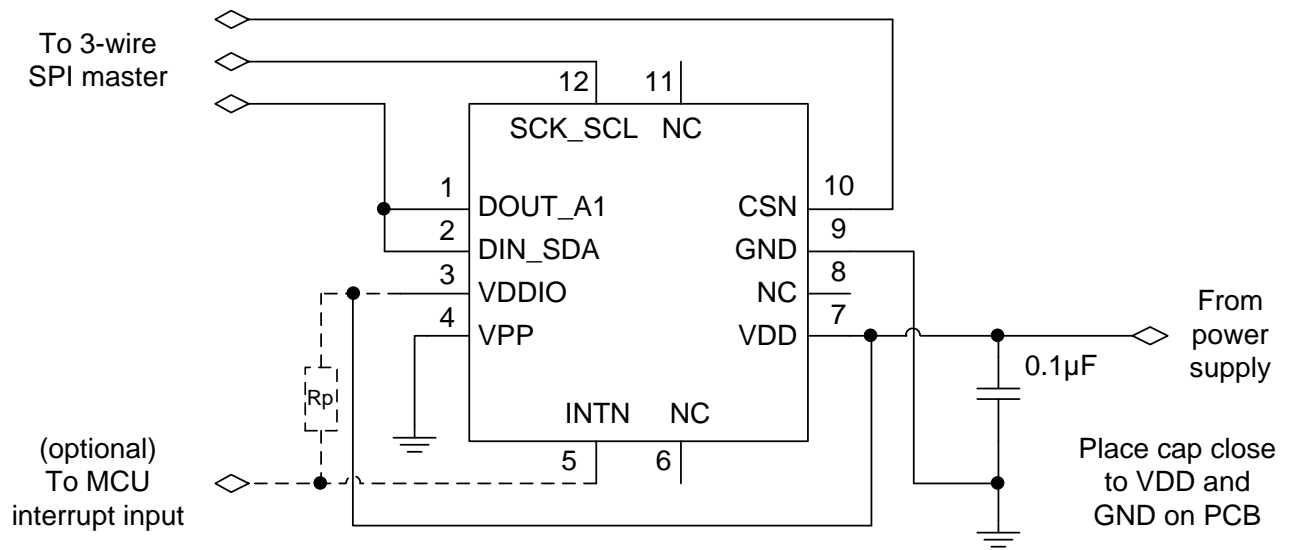

NOTE Rp: Attach typical 4.7kΩ pullup resistor if INTN is defined as open-drain.

Figure 7. Typical 3-wire SPI Application Circuit



3.5 Tape and Reel

Devices are shipped in reels, in standard cardboard box packaging. See [Figure 8. MC3630 Tape Dimensions](#) and [Figure 9. MC3630 Reel Dimensions](#).

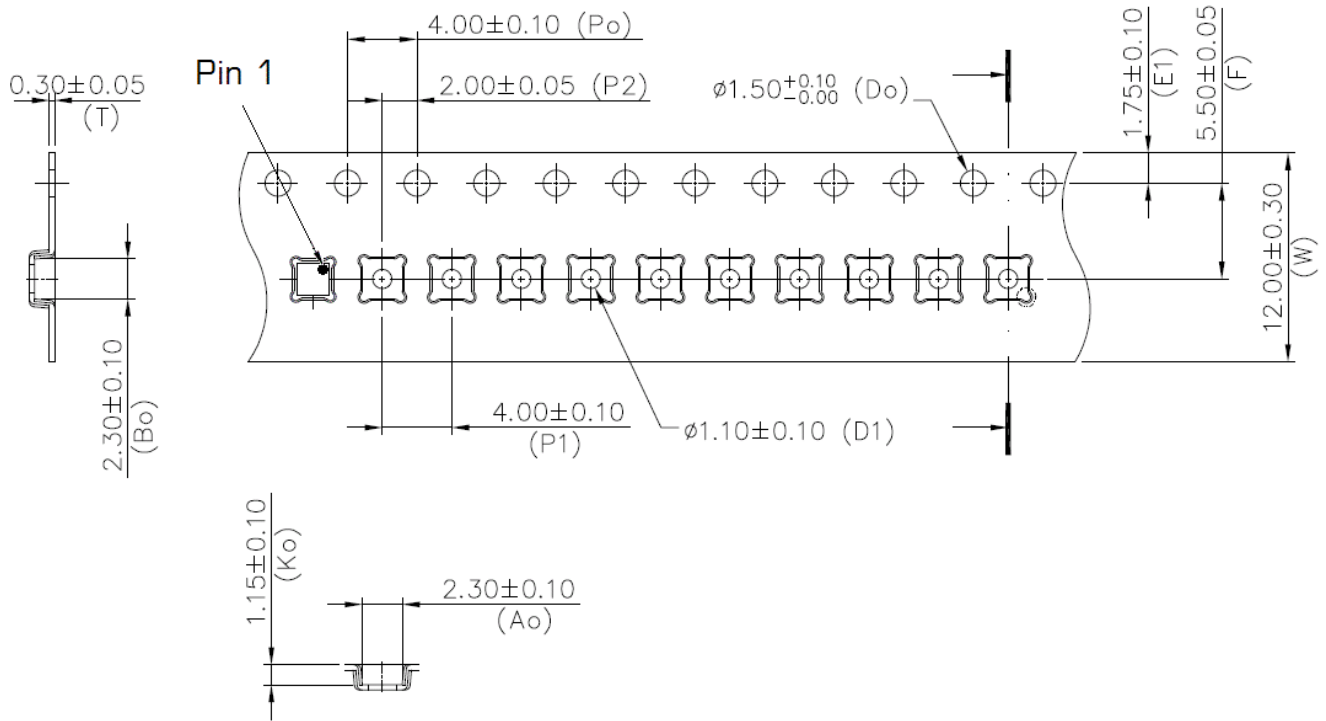

- Dimensions in mm.

Figure 8. MC3630 Tape Dimensions



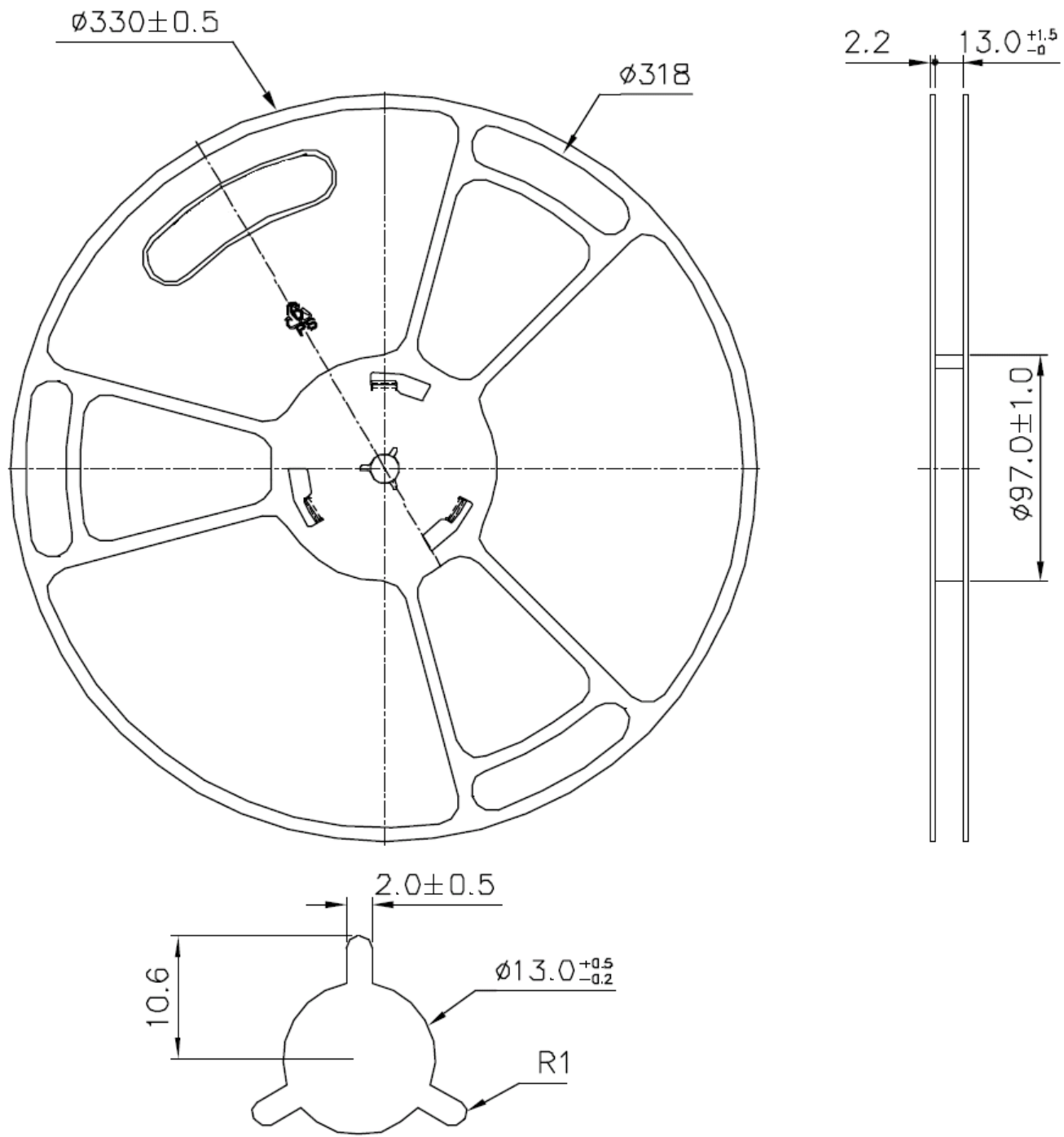

- Dimensions in mm.

Figure 9. MC3630 Reel Dimensions



3.6 Soldering Profile

The LGA package follows the reflow soldering classification profiles described in *Joint Industry Standard, Moisture/Reflow Sensitivity Classification for Nonhermetic Surface Mount Devices*, document number J-STD-020E. Reflow soldering has a peak temperature (T_p) of 260°C

3.7 Shipping and Handling Guidelines

Shipping and handling follow the standards described in *Joint Industry Standard, Handling, Packing, Shipping and Use of Moisture/Reflow Sensitive Surface Mount Devices*, document number J-STD-033C.

The following are additional handling guidelines (refer to the mCube document, PCB Design, Device Handling and Assembly Guidelines, document number AN-001, for more information):

- While the mechanical sensor is designed to handle high-g shock events, direct mechanical shock to the package should be avoided.
- SMT assembly houses should use automated assembly equipment with either plastic nozzles or nozzles with compliant tips (for example, soft rubber or silicone).
- Avoid g-forces beyond the specified limits during transportation.
- Handling and mounting of sensors should be done in a defined and qualified installation.

3.8 Moisture Sensitivity Level Control

The following are storage recommendations (refer to the mCube document, PCB Design, Device Handling and Assembly Guidelines, document number AN-001, for more information):

- Store the tape and reel in the *unopened* dry pack, until required on the assembly floor.
- If the dry pack has been opened or the reel has been removed from the dry pack, reseal the reel inside of the dry pack with a black protective belt. Avoid crushing the tape and reel.
- Store the cardboard box in a vertical position.



4 Specifications

4.1 Absolute Maximum Ratings

Parameters exceeding the Absolute Maximum Ratings may permanently damage the device.

Rating	Symbol	Minimum / Maximum Value	Unit
Supply Voltages	Pins VDD, VDDIO	-0.3 / +3.6	V
Acceleration, any axis, 100 μ s	g_{MAX}	10000	g
Ambient operating temperature	T_{OP}	-40 / +85	$^{\circ}C$
Storage temperature	T_{STG}	-40 / +125	$^{\circ}C$
ESD human body model	HBM	± 2000	V
Input voltage to non-power pin	Pins CSN, DIN_SDA, DOUT_A1, INTN, and SCK_SCL	-0.3 / (VDDIO + 0.3) or 3.6 whichever is lower	V

Table 3. Absolute Maximum Ratings



4.2 Sensor Characteristics

VDD = VDDIO = 1.8V, T_{op} = 25 °C unless otherwise noted

Parameter	Conditions	Min	Typ	Max	Unit
Acceleration range			±2		g
			±4		
			±8		
			±12		
			±16		
Sensitivity		8		4096	LSB/g
Sensitivity Temperature Coefficient ¹			0.015		%/°C
Zero-g Offset	Post-board mount, ODR ≤ 400Hz		± 40		mg
Zero-g Offset Temperature Coefficient ¹			± 1		mg/°C
Noise ¹ @ 100Hz			WAKE MODES:		mg RMS
			Ultra-Low Power, Avg X&Y&Z:	6.5	
			Low Power, Avg X&Y&Z:	4.4	
			Precision, Avg X&Y&Z:	1.7	
			SNIFF MODES:		
			Ultra-Low Power, Avg X&Y&Z:	40	
Low Power, Avg X&Y&Z:	25				
Precision, Avg X&Y&Z:	5				
Nonlinearity ¹			1		% FS
Cross-axis Sensitivity ¹	Between any two axes		1		%

Table 4. Sensor Characteristics

¹ Values are based on device characterization, not tested in production.



4.3 Electrical and Timing Characteristics

4.3.1 ELECTRICAL POWER AND INTERNAL CHARACTERISTICS

Parameter	Conditions	Symbol	Min	Typ	Max	Unit
Internal voltage ²	Pin VDD Rise-time < 40mSec	VDD	1.7	1.8	3.6	V
I/O voltage	Pin VDDIO Rise-time < 40mSec	VDDIO	1.7	1.8	3.6	V
PSRR	Decoupling capacitor 0.1uF @ <100ohms, 100mV sine wave, 10Hz – 10KHz on VDD or VDDIO	PSRR		-40		dB

Test condition: VDD = VDDIO = 1.8V, T_{op} = 25 °C unless otherwise noted

Parameter	Conditions	Symbol	Min	Typ	Max	Unit
Sleep current	SPI interface	I _{ddslp}		0.1		μA
Sniff current	6Hz un	I _{ddsfnf}		0.4		μA
Selected wake supply current (see also 7.11)	Precision, 14Hz	I _{dd14p}		5		μA
	Ultra-Low Power, 25Hz	I _{dd25ulp}		0.9		
	Ultra-Low Power, 50Hz	I _{dd50ulp}		1.6		
	Low Power, 54Hz	I _{dd54lp}		2.7		
	Precision, 55Hz	I _{dd55p}		18		
	Ultra-Low Power, 100Hz	I _{dd100ulp}		2.8		
	Precision, 100Hz	I _{dd100p}		36		
	Low Power, 210Hz	I _{dd210lp}		11		
Ultra-Low Power, 1300Hz	I _{dd1300ulp}		36			
Pad Leakage	Per I/O pad	I _{pad}		0.01		μA

Table 5. Electrical Characteristics – Voltage and Current

² Min and Max limits are hard limits without additional tolerance.



4.3.2 ELECTRICAL CHARACTERISTICS

Parameter	Symbol	Min	Max	Unit
LOW level input voltage	VIL	-0.5	0.3*VDDIO	V
HIGH level input voltage	VIH	0.7*VDDIO	-	V
Hysteresis of Schmitt trigger inputs	V _{hys}	0.05*VDDIO	-	V
Output voltage, pin INTN, I _{ol} ≤ 2 mA	V _{ol}	0	0.4	V
	V _{oh}	0	0.9*VDDIO	V
Output voltage, pin DIN_SDA (open drain), I _{ol} ≤ 1 mA	V _{ols}	-	0.1*VDDIO	V
Input current, pins DIN_SDA and SCK_SCL (input voltage between 0.1*VDDIO and 0.9*VDDIO max)	I _i	-10	10	μA
Capacitance, pins DIN_SDA and SCK_SCL ³	C _i	-	10	pF

Table 6. Electrical Characteristics – Interface

NOTES:

- If multiple slaves are connected to the I2C signals in addition to this device, only 1 pull-up resistor on each of SDA and SCL should exist. Also, care must be taken to not violate the I2C specification for capacitive loading.
- When pin VDDIO is not powered and set to 0V, INTN, DIN_SDA and SCK_SCL will be held to VDDIO plus the forward voltage of the internal static protection diodes, typically about 0.6V.
- When pin VDDIO is disconnected from power or ground (e.g. Hi-Z), the device may become inadvertently powered up through the ESD diodes present on other powered signals.

³ Values are based on device characterization, not tested in production.



4.3.3 I2C TIMING CHARACTERISTICS

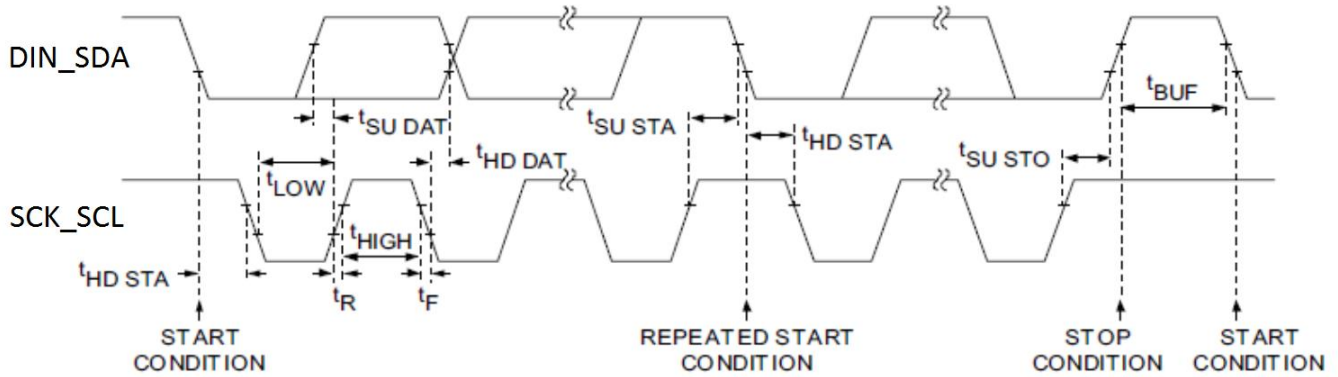

Figure 10. I2C Interface Timing

Parameter	Description	Standard Mode		Fast Mode		Fast Mode Plus		Units
		Min	Max	Min	Max			
f_{SCL}	SCL clock frequency	0	100	0	400	0	1000	kHz
$t_{HD;STA}$	Hold time (repeated) START condition	4.0	-	0.6	-	0.26	-	μs
t_{LOW}	LOW period of the SCL clock	4.7	-	1.3	-	0.5	-	μs
t_{HIGH}	HIGH period of the SCL clock	4.0	-	0.6	-	0.26	-	μs
$t_{SU;STA}$	Set-up time for a repeated START condition	4.7	-	0.6	-	0.26	-	μs
$t_{HD;DAT}$	Data hold time	5.0	-	-	-	-	-	μs
$t_{SU;DAT}$	Data set-up time	250	-	100	-	50	-	ns
$t_{SU;STO}$	Set-up time for STOP condition	4.0	-	0.6	-	0.26	-	μs
t_{BUF}	Bus free time between a STOP and START	4.7	-	1.3	-	0.5	-	μs

Table 7. I2C Timing Characteristics

NOTE: Values are based on I2C Specification requirements, not tested in production.



4.3.4 SPI TIMING CHARACTERISTICS

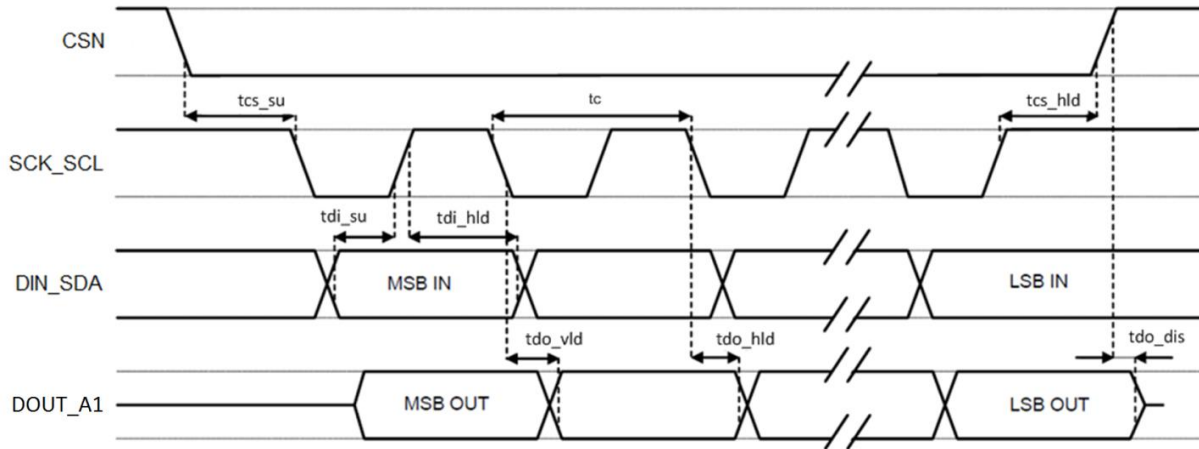

Figure 11. SPI Interface Timing Waveform

Symbol	Parameter	Value			Units
		Min	Typ	Max	
tc	SPI SCK_SCL Clock Cycle	500			ns
fc	SPI SCK_SCL Clock Frequency		8 ⁴		MHz
tcs_su	SPI CSN Setup Time	6			ns
tcs_hld	SPI CSN Hold Time	8			ns
tdi_su	SPI DIN_SDA Input Setup Time	5			ns
tdi_hld	SPI DIN_SDA Input Hold Time	15			ns
tdo_vld	SPI DOUT_A1 Valid Output Time			50	ns
tdo_hld	SPI DOUT_A1 Output Hold Time	9			ns
tdo_dis	SPI DOUT_A1 Output Disable Time			50	ns

Table 8. SPI Interface Timing Parameters

⁴ Values are based on device characterization.



5 General Operation

The device supports the reading of samples and device status upon interrupt or via polling. It contains a 12-bit 32 sample FIFO with programmable watermark. The device is internally clocked but also includes a manual trigger mode. It can be put into several low power modes, depending upon the desired sensing application. The device can run in full-featured mode from its fast internal clock or from a slower heartbeat clock, with limited functionality and at lower power. The device can connect as a slave to either a SPI or I2C master.

5.1 Sensor Sampling

X, Y and Z accelerometer data is stored in registers XOUT, YOUT, and ZOUT registers. The data is represented as 2's complement format.

The desired resolution and full scale acceleration range are set in the RANGE_C register.

5.2 Offset and Gain Calibration

The default digital offset and gain calibration data can be read from the device, if necessary, in order to reduce the effects of post-assembly influences and stresses which may cause the sensor readings to be offset from their factory values.

5.3 Reset

Immediate after a power up event, the first transaction can be either I2C or SPI instruction. If chip select is pull low, the device assumes it is in SPI mode.

The device can be completely reset via an I2C or SPI instruction. Writing 0x1 into register 0x24[6] causes a power-on reset operation to execute. No attempt should be made to access registers within 1mSec after issuing this operation. The device must be placed in STANDBY mode before executing the reset. The pin DOUT_A1 is sampled for the purposes of setting the I2C device address after this reset operation.

NOTE: Immediately after a RESET or power-up event, several registers must be written with initialization values as shown below. The recommended sequence is:

Step	Address	Value which must be written	Comment
1	0x10	0x01	Go to standby
2	0x24	0x40	Reset (or Power-On)
3	Wait at least 1mSec		Wait for reset to complete
4	0x0D	For SPI: 0x80 For I2C: 0x40	Specify interface
5	0x0F	0x42	Initialization
6	0x20	0x01	Initialization
7	0x21	0x80	Initialization
8	0x28	0x00	Initialization
9	0x1A	0x00	Initialization
10	Configure remaining registers and use sensor as normal		



Table 9. Recommended Initialization Sequence

5.4 Reload

The device registers can be reloaded from OTP via an I2C or SPI instruction. Writing 0x1 into register 0x24[7] causes a reload operation to execute. The contents of OTP are reloaded into the register set. However any non-loaded register locations will not be affected. No attempt should be made to access registers within 1mSec after issuing this operation. The device must be placed in STANDBY mode before executing the reset.

The pin DOUT_A1 is sampled for the purposes of setting the I2C device address after this reload operation.



5.5 Operational Modes

The device has various modes of operation as described below:

Mode	Description and Comments
SLEEP	SLEEP is the lowest power mode. The internal regulators are enabled and much of the chip is disabled. The SLEEP mode is the default POR mode. This command is available at any time, although up to three periods of the internal heartbeat clock may be required to complete the transition.
STANDBY	STANDBY is a low power mode. All internal regulators are enabled with internal main and heartbeat clocks enabled. The default STANDBY frequency for the heartbeat clock is ~500 Hz. TRIG mode operation can be executed only from this mode. Software must change the mode to SLEEP or STANDBY by writing 0x1 into register 0x10[2:0] before writing to any other register.
SNIFF	SNIFF is a lower power, limited activity detection mode; Sniff circuitry is enabled and sniff-only sampling is enabled. There are no FIFO operations, and hardware will automatically transition to CWAKE mode upon activity detection.
CWAKE	CWAKE or continuous wake is the typical XYZ sampling mode. Sample data is written to the output registers, or the FIFO when enabled. Hardware will automatically transition to CWAKE mode upon SNIFF activity detection.
SWAKE	SNIFF and CWAKE circuitry are both active simultaneously. Sniff circuitry is enabled and XYZ samples are written to the output registers, or the FIFO when enabled.
TRIG	The device produces a fixed number of samples, between 1 and 254, or continuously. This mode ignores the setting in the ODR, but uses the STB_RATE[2:0] clock setting in register 0x12[7:5] as the sampling rate. The trigger can be set to come from the external pin INTN or a write to register bit 0x10[7].

Table 10. Operational Modes



5.6 Mode State Machine Flow

Figure 12. Mode Operational Flow shows the operational mode flow for the device. The device defaults to SLEEP mode following power-on. Mode transitions occur at an approximate rate of ~500Hz. Depending on the operation, the MODE State Machine may trigger events that auto-clear or set the MCTRL[2:0] bits in register 0x10[2:0] after a particular command is chosen.

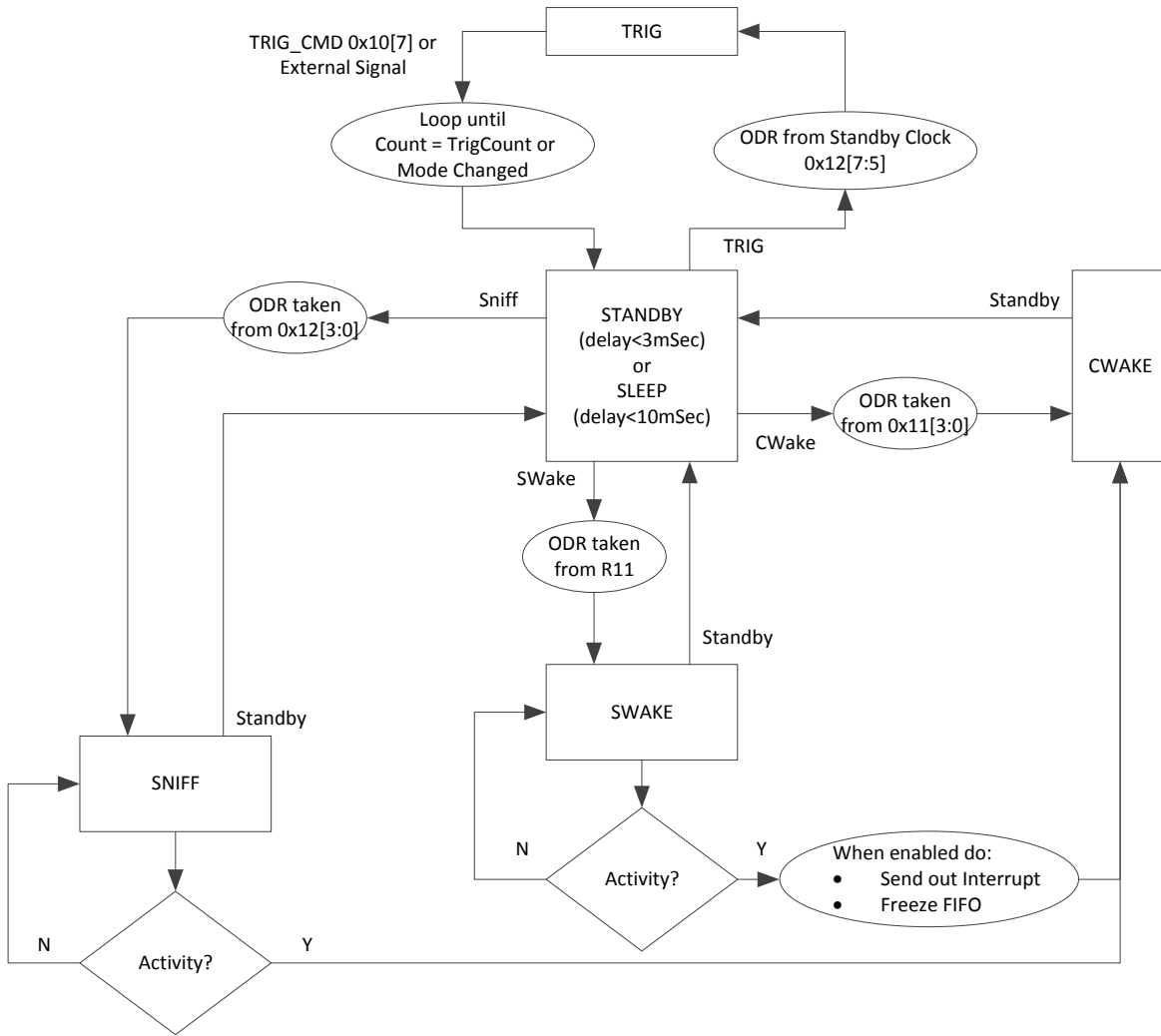

Figure 12. Mode Operational Flow



6 Interfaces

6.1 SPI vs I2C Operation Modes

The device contains both I2C and SPI slave interfaces which share common pins. However, only one interface can be active for correct device operation. Once the device completes POR or a hard reset, both interfaces are active.

After power-up and any reset of the device (0x24[6] = 0x1), the first transaction to the device must be to select I2C or SPI interface by writing to 0x1 into register 0x0D[6] for I2C or 0x1 into register 0x0D[7] for SPI 4 wire or 0x1 into register 0x0D[5] for SPI 3 wire. The situation where bits are set at the same time must be avoided or unstable device operation could occur.

6.2 I2C Physical Interface

The I2C slave interface operates at a maximum speed of 1 MHz in I2C “Fast Mode Plus”. The SDA (data) is an open-drain, bi-directional pin and the SCL (clock) is an input pin.

The device always operates as an I2C slave.

An I2C master initiates all communication and data transfers and generates the SCK_SCL clock that synchronizes the data transfer. The I2C device address depends upon the state of pin DOUT_A1 during power-up as shown in the table below.

<u>7-bit Device ID</u>	<u>8-bit Address (Write)</u>	<u>8-bit Address (Read)</u>	<u>DOUT_A1 level upon power-up</u>
0x4C (0b1001100)	0x98	0x99	GND
0x6C (0b1101100)	0xD8	0xD9	VDD

Table 11. I2C Address Selection

The I2C interface remains active as long as power is applied to the VDDIO pin. In STANDBY mode the device responds to I2C read and write cycles, but interrupts cannot be cleared. All registers can be written in the SLEEP or STANDBY modes but in CWAKE mode, only the (0x10) Mode Control Register can be modified.

Internally, the registers which are used to store samples are clocked by the sample clock and gated by I2C activity. Therefore, in order to allow the device to collect and present samples in the sample registers at least one I2C STOP condition must be present between samples.

Refer to the I2C specification for a detailed discussion of the protocol. Per I2C requirements, when the I2C interface is enabled, DIN_SDA is an open drain, bi-directional pin. Pins SCK_SCL and DIN_SDA each require an external pull-up resistor, typically 4.7kΩ.



6.3 I2C Message Format

NOTE: At least one I2C STOP condition must be present between samples in order for the device to update the sample data registers.

The device uses the following general format for writing to the internal registers. The I2C master generates a START condition, and then supplies the 7-bit device ID. The 8th bit is the R/W# flag (write cycle = 0). The device pulls DIN_SDA low during the 9th clock cycle indicating a positive ACK.

The second byte is the 8-bit register address of the device to access, and the last byte is the data to write.

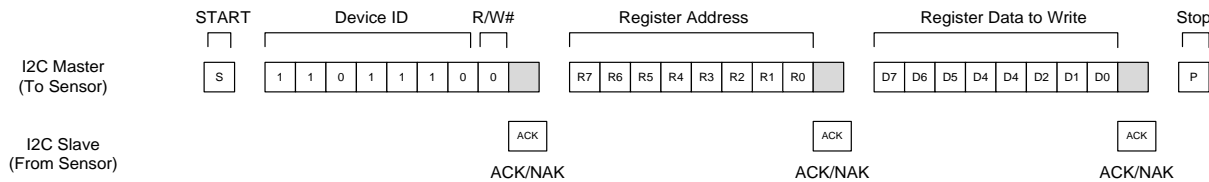

Figure 13. I2C Message Format, Write Cycle, Single Register Write

In a read cycle, the I2C master writes the device ID (R/W#=0) and register address to be read. The master issues a RESTART condition and then writes the device ID with the R/W# flag set to '1'. The device shifts out the contents of the register address.

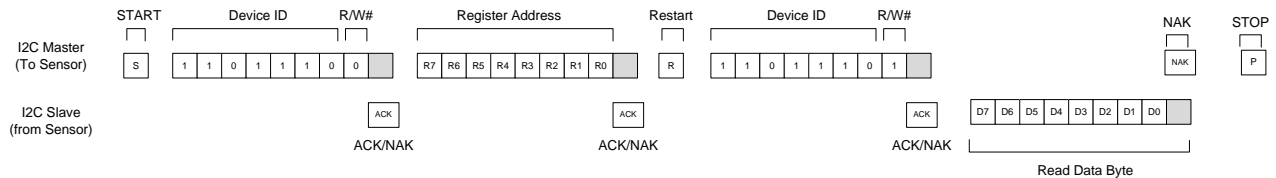

Figure 14. I2C Message Format, Read Cycle, Single Register Read

The I2C master may write or read consecutive register addresses by writing or reading additional bytes after the first access. The device will internally increment the register address.

NOTE: See (0x0E) Feature Register 2 for address wrap details.

6.4 SPI Physical Interface

The device always operates as an SPI slave. An SPI master must initiate all communication and data transfers and generate the SCK_SCL clock that synchronizes the data transfer. The CSN pin must be pulled up to VDDIO when the SPI interface is not in use. The SPI interface can operate in 3-wire or 4-wire mode.



6.5 SPI 3-Wire Mode

SPI 3-wire mode is disabled by default. To enable 3-wire mode, the first write to the device should immediately enable this feature in register (0x0D) Feature Register 1. In 3-wire mode the pins DOUT_A1 and DIN_SDA must be connected on the PCB. Anytime there is a reset to the device, a POR event, or a power cycle the SPI 3-wire configuration will reset to 4-wire mode.

6.6 SPI Protocol

The general protocol for the SPI interface is shown in the figures below. The falling edge of CSN initiates the start of the SPI bus cycle. The maximum SPI clock speed is 4Mhz and the timing scheme follows clock polarity (CPOL) = 1 and clock phase (CPHA) = 1. The first byte of the transaction is the command/address byte. Because the register address space is 64 locations, a total of 6 address bits are required for each SPI bus cycle. During clock '1', the R/W# bit is set to '0' for a write cycle or '1' for a read cycle.

The interface supports 2 types of addressing: 1-byte (typically used) and 2-byte (to support legacy hardware). In the case of 2-byte addressing, the bits occurring during clocks 2 and 9-16 must be driven to '0' for the address to be correctly decoded. Each read or write transaction always requires a minimum of 16 or 24 cycles of the SCK_SCL pin.

When the SPI master is writing data, data may change when the clock is low, and must be stable on the clock rising edge. Similarly, output data written to the SPI master is shifted out on the falling edge of clock and can be latched by the master on the rising edge of the clock. Serial data in or out of the device is always MSB first.

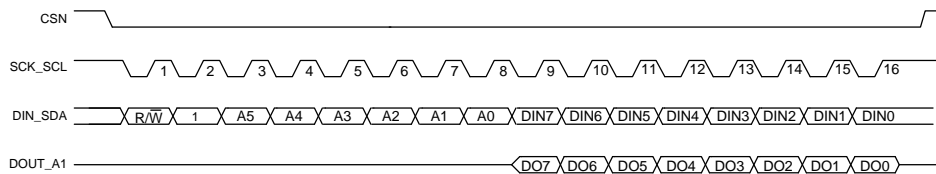

Figure 15. General SPI Protocol, 1-Byte Address

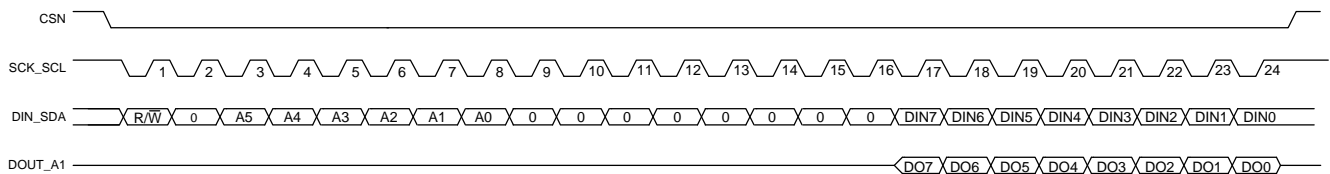

Figure 16. General SPI Protocol, 2-Byte Address (legacy)

NOTE: Either 1-byte or 2-byte addressing may be used for any SPI transaction, although for simplicity, the remaining timing diagrams show only 1-byte addressing.



6.7 SPI Register Write Cycle - Single

A single register write consists of a 16-clock transaction. As described above, the first bit is set to '0' indicating a register write followed by the register address.

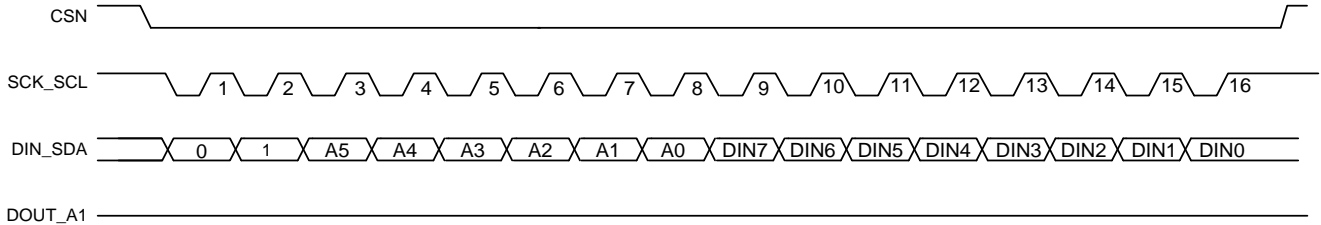

Figure 17. SPI Register Write Cycle - Single

6.8 SPI Register Write Cycle - Burst

A burst (multi-byte) register write cycle uses the address specified at the beginning of the transaction as the starting register address. Internally the address will auto-increment to the next consecutive address for each additional byte (8-clocks) of data written beyond clock 8.

NOTE: See (0x0E) Feature Register 2 for address wrap details.

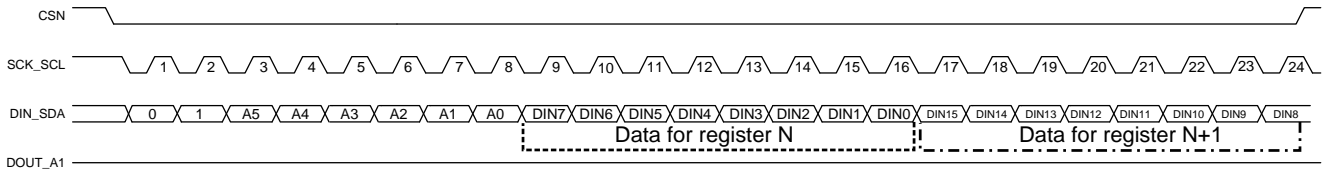

Figure 18. SPI Register Write Cycle - Burst (2-register burst example)

6.9 SPI Register Read Cycle - Single

A single register read consists of a 16-clock transaction. As described above, the first bit is set to '1' indicating a register read followed by the register address.

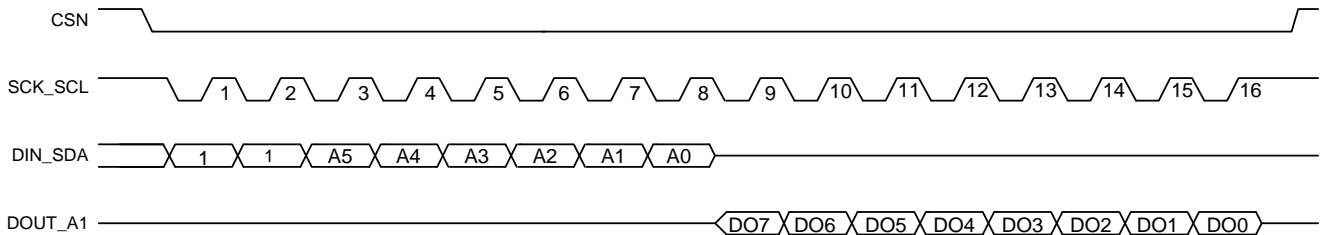

Figure 19. SPI Register Read Cycle - Single



6.10 SPI Register Read Cycle - Burst

A burst (multi-byte) register read cycle uses the address specified at the beginning of the transaction as the starting register address. Internally the address will auto-increment to the next consecutive address for each additional byte (8-clocks) of data read beyond clock 8.

NOTE: See (0x0E) Feature Register 2 for address wrap details.

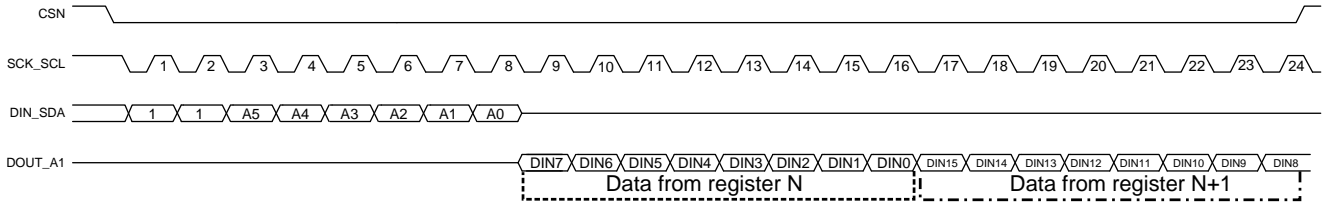

Figure 20. SPI Register Read Cycle - Burst (2 register burst example)

6.11 SPI Status Option

The device supports an optional SPI status feature, only in SPI 4-wire mode. This feature is enabled in register (0x0E) Feature Register 2. During the first 6-bits of any SPI transaction (immediately after the falling edge of CSN), the DOUT_A1 pin will output six status bits related to the device. Following the 6th clock cycle, the device will float the DOUT_A1 pin before a possible read cycle begins. The status bits sent are shown below:

Bit 7 (First Out)	Bit6	Bit5	Bit 4	Bit 3	Bit 2	Bit 1	Bit 0 (Last Out)
INT_PEND	FIFO_THRESH	FIFO_FULL	FIFO_EMPTY	NEW_DATA	WAKE	0	0

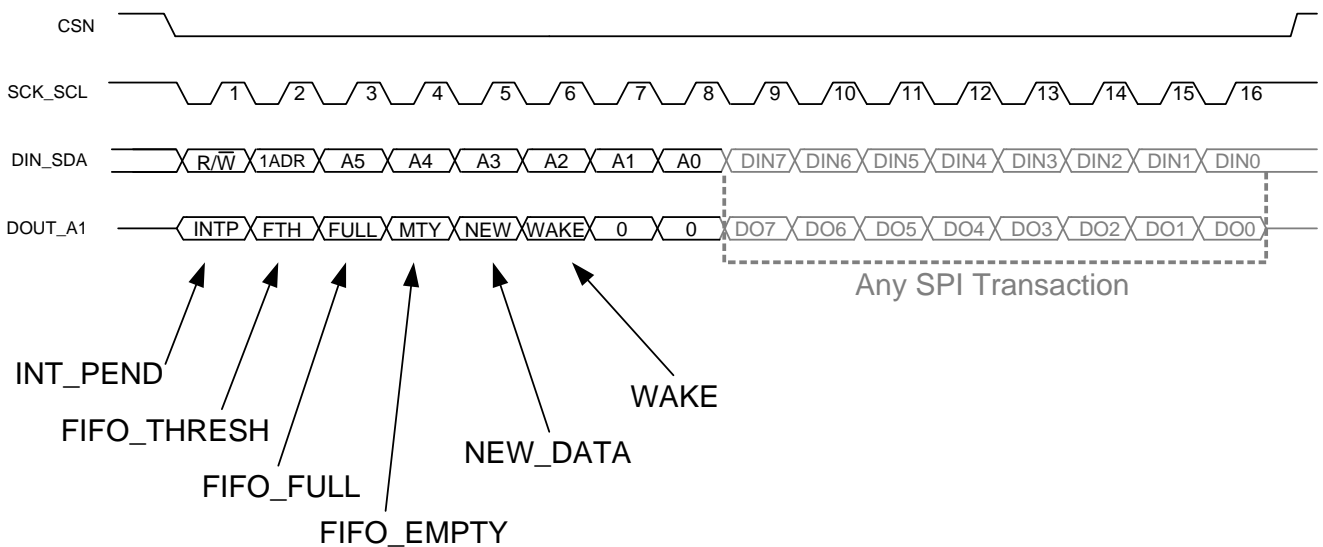

Figure 21. SPI Status bits



6.12 SPI High-Speed Mode

To achieve SPI speed greater than 2MHz, use the following sequence:

- Start SPI at low speed (less than 2MHz)
- Enable SPI mode –
 - o “SPI_EN” in section 7.7 (0x0D) Feature Register 1
- Enable high speed SPI mode –
 - o “SPI_HS_EN” in section 7.20 (0x1C) Power Mode Control Register
- Increase SPI speed up to 8MHz



7 Register Interface

The device has a simple register interface which allows an SPI or I2C master to configure and monitor all aspects of the device. This section lists an overview of user programmable registers. By convention, bit 0 is the least significant bit (LSB) of a byte register.



7.1 Register Summary

Addr	Name	Description	Bit 7	Bit 6	Bit 5	Bit 4	Bit 3	Bit 2	Bit 1	Bit 0	POR Value	R/W [†]
0x00	EXT_STAT_1	Extended Status 1	RESV	RESV	RESV	RESV	I2C_AD0	RESV	RESV	RESV	0x00	R
0x01	EXT_STAT_2	Extended Status 2	SNIFF_DETECT	SNIFF_EN	OTP_BUSY	RESV	RESV	RESV	PD_CLK_STAT	OVR_DATA	0x04	R
0x02	XOUT_LSB	XOUT_LSB	XOUT[7]	XOUT[6]	XOUT[5]	XOUT[4]	XOUT[3]	XOUT[2]	XOUT[1]	XOUT[0]	0x00	R
0x03	XOUT_MSB	XOUT_MSB	XOUT[15]	XOUT[14]	XOUT[13]	XOUT[12]	XOUT[11]	XOUT[10]	XOUT[9]	XOUT[8]	0x00	R
0x04	YOUT_LSB	YOUT_LSB	YOUT[7]	YOUT[6]	YOUT[5]	YOUT[4]	YOUT[3]	YOUT[2]	YOUT[1]	YOUT[0]	0x00	R
0x05	YOUT_MSB	YOUT_MSB	YOUT[15]	YOUT[14]	YOUT[13]	YOUT[12]	YOUT[11]	YOUT[10]	YOUT[9]	YOUT[8]	0x00	R
0x06	ZOUT_LSB	ZOUT_LSB	ZOUT[7]	ZOUT[6]	ZOUT[5]	ZOUT[4]	ZOUT[3]	ZOUT[2]	ZOUT[1]	ZOUT[0]	0x00	R
0x07	ZOUT_MSB	ZOUT_MSB	ZOUT[15]	ZOUT[14]	ZOUT[13]	ZOUT[12]	ZOUT[11]	ZOUT[10]	ZOUT[9]	ZOUT[8]	0x00	R
0x08	STATUS_1	Status 1	INT_PEND	FIFO_THRESH	FIFO_FULL	FIFO_EMPTY	NEW_DATA	MODE[2]	MODE[1]	MODE[0]	0x00	R
0x09	STATUS_2	Status 2	INT_SWAKE	INT_FIFO_THRESH	INT_FIFO_FULL	INT_FIFO_EMPTY	INT_ACQ	INT_WAKE	RESV	RESV	0x00	R
0x0A – 0x0C			RESERVED									
0x0D	FREG_1	Feature 1	SPI_EN	I2C_EN	SPB_EN	INTSC_EN	FREEZE	0	0	0	0x00	W
0x0E	FREG_2	Feature 2	EXT_TRIG_EN	EXT_TRIG_POL	FIFO_STREAM	I2CINT_WRCLE	FIFO_STAT_EN	SPI_STAT_EN	FIFO_BURST	WRAPA	0x00	W
0x0F	INIT_1	Initialization 1	0	1	0	0	0	0	1	0	(See note)	WO
0x10	MODE_C	Mode Control	TRIG_CMD	Z_AXIS_PD	Y_AXIS_PD	X_AXIS_PD	RESV	MCTRL[2]	MCTRL[1]	MCTRL[0]	0x00	W
0x11	RATE_1	Rate 1	RESV	MAN_SEL[2]	MAN_SEL[1]	MAN_SEL[0]	WR[3]	WR[2]	WR[1]	WR[0]	0x00	W
0x12	SNIFF_C	Sniff Control	STB_RATE[2]	STB_RATE[1]	STB_RATE[0]	0	SNIFF_SR[3]	SNIFF_SR[2]	SNIFF_SR[1]	SNIFF_SR[0]	0x00	W
0x13	SNIFFTH_C	Sniff Threshold Control	SNIFF_MODE	SNIFF_AND_OR	SNIFF_TH[5]	SNIFF_TH[4]	SNIFF_TH[3]	SNIFF_TH[2]	SNIFF_TH[1]	SNIFF_TH[0]	0x00	WS
0x14	SNIFFCF_C	Sniff Configuration	SNIFF_RESET	SNIFF_MUX[2]	SNIFF_MUX[1]	SNIFF_MUX[0]	SNIFF_CNTEN	SNIFF_THADR[2]	SNIFF_THADR[1]	SNIFF_THADR[0]	0x00	W
0x15	RANGE_C	Range Resolution Control	RESV	RANGE[2]	RANGE[1]	RANGE[0]	RESV	RES[2]	RES[1]	RES[0]	0x00	W
0x16	FIFO_C	FIFO Control	FIFO_RESET	FIFO_EN	FIFO_MODE	FIFO_TH[4]	FIFO_TH[3]	FIFO_TH[2]	FIFO_TH[1]	FIFO_TH[0]	0x00	W
0x17	INTR_C	Interrupt Control	INT_SWAKE	INT_FIFO_THRESH	INT_FIFO_FULL	INT_FIFO_EMPTY	INT_ACQ	INT_WAKE	IAH	IPP	0x00	R
0x18	CHIP_ID	Chip ID Register	0	1	1	1	0	0	0	1	0x71	R
0x19			RESERVED									
0x1A	INIT_3	Initialization 3	0	0	0	0	0	0	0	0	0x00	RW



MC3630 3-Axis Accelerometer

Addr	Name	Description	Bit 7	Bit 6	Bit 5	Bit 4	Bit 3	Bit 2	Bit 1	Bit 0	POR Value	R/W ⁴
0x1C	PMCR	Power Mode Control	SPL_HS_EN	SPM[2]	SPM[1]	SPM[0]	RESV	CSPM[2]	CSPM[1]	CSPM[0]	0x00	W
0x1D – 0x1F		RESERVED										
0x20	DMX	Drive Motion X	0	0	0	0	DNX	DPX	0	1	0x00	W
0x21	DMY	Drive Motion Y	1	0	0	0	DNY	DPY	0	0	(See table)	W
0x22	DMZ	Drive Motion Z	0	0	0	0	DNZ	DPZ	0	0	0x00	W
0x23		RESERVED										
0x24	RESET	Reset	RELOAD	RESET	RESV	RESV	RESV	RESV	RESV	RESV	0x00	W
0x25 – 0x27		RESERVED										
0x28	INIT_2	Initialization Register 2	0	0	0	0	0	0	0	0	0x00	W
0x29	TRIGC	Trigger Count	TRIGC[7]	TRIGC[6]	TRIGC[5]	TRIGC[4]	TRIGC[3]	TRIGC[2]	TRIGC[1]	TRIGC[0]	0x00	W
0x2A	XOFFL	X-Offset LSB	XOFF[7]	XOFF[6]	XOFF[5]	XOFF[4]	XOFF[3]	XOFF[2]	XOFF[1]	XOFF[0]	Per chip	W
0x2B	XOFFH	X-Offset MSB	XGAIN[8]	XOFF[14]	XOFF[13]	XOFF[12]	XOFF[11]	XOFF[10]	XOFF[9]	XOFF[8]	Per chip	W
0x2C	YOFFL	Y-Offset LSB	YOFF[7]	YOFF[6]	YOFF[5]	YOFF[4]	YOFF[3]	YOFF[2]	YOFF[1]	YOFF[0]	Per chip	W
0x2D	YOFFH	Y-Offset MSB	YGAIN[8]	YOFF[14]	YOFF[13]	YOFF[12]	YOFF[11]	YOFF[10]	YOFF[9]	YOFF[8]	Per chip	W
0x2E	ZOFFL	Z-Offset LSB	ZOFF[7]	ZOFF[6]	ZOFF[5]	ZOFF[4]	ZOFF[3]	ZOFF[2]	ZOFF[1]	ZOFF[0]	Per chip	W
0x2F	ZOFFH	Z-Offset MSB	ZGAIN[8]	ZOFF[14]	ZOFF[13]	ZOFF[12]	ZOFF[11]	ZOFF[10]	ZOFF[9]	ZOFF[8]	Per chip	W
0x30	XGAIN	X Gain	XGAIN[7]	XGAIN[6]	XGAIN[5]	XGAIN[4]	XGAIN[3]	XGAIN[2]	XGAIN[1]	XGAIN[0]	Per chip	W
0x31	YGAIN	Y Gain	YGAIN[7]	YGAIN[6]	YGAIN[5]	YGAIN[4]	YGAIN[3]	YGAIN[2]	YGAIN[1]	YGAIN[0]	Per chip	W
0x32	ZGAIN	Z Gain	ZGAIN[7]	ZGAIN[6]	ZGAIN[5]	ZGAIN[4]	ZGAIN[3]	ZGAIN[2]	ZGAIN[1]	ZGAIN[0]	Per chip	W
0x33 – 0x3F		RESERVED										

Table 12. Register Summary

⁴ 'R' registers are read-only. 'W' registers are read-write. 'WO' registers are write only. 'WS' registers are shadow registers that is accessible via a single register portal.



7.2 (0x00) Extended Status Register 1

This register contains status for the I2C address of the device.

Addr	Name	Bit								POR Value	R/W
		7	6	5	4	3	2	1	0		
0x00	EXT_STAT_1	RESV	RESV	RESV	RESV	I2C_AD0	RESV	RESV	RESV	00000000	R

Bit	Name	Description
[2:0]	RESV	Reserved
3	I2C_AD0_BIT	Value of I2C slave address obtained from reading the DOUT_A1 pin at POR. If this bit is '1', the 7-bit base address of the I2C slave changes from 0x4C to 0x6C.
[7:4]	RESV	Reserved

Table 13. Extended Status Register 1 Settings



7.3 **(0x01) Extended Status Register 2**

The device status register reports various conditions of the device data, clock and sniff circuitry.

Addr	Name	Bit								POR Value	R/W
		7	6	5	4	3	2	1	0		
0x01	EXT_STAT_2	SNIFF_DETECT	SNIFF_EN	OTP_BUSY	RESV	RESV	RESV	PD_CLK_STAT	OVR_DATA	0x04	RO

Bit	Name	Description
0	OVR_DATA	0: Previous acceleration sample has not been overwritten before read by host 1: Previous acceleration sample was not read by host and has been overwritten.
1	PD_CLK_STAT	Returns the power-down status of the clocks. 0: Clocks are enabled. 1: Clocks are disabled.
[4:2]	RESV	Reserved
5	OTP_BUSY	OTP VDD status bit: 0: OTP_VDD supply is not enabled, OTP is powered down. 1: OTP_VDD supply is enabled, OTP is powered.
6	SNIFF_EN	SNIFF mode enable flag: 0: SNIFF mode is not active. 1: SNIFF mode is active.
7	SNIFF_DETECT	SNIFF wakeup or detect flag: 0: No sniff event detected. 1: Sniff event detected, move to CWAKE mode.

Table 14. Extended Status Register 2 Settings



7.4 **(0x02 – 0x07) XOUT, YOUT & ZOUT Data Output Registers**

The measurements from sensors for the 3-axes are available in these 3 registers. The most-significant bit of the value is the sign bit, and is sign extended to the higher bits.

Software must set only one of the bits SPI_EN or I2C_EN or SPI3_EN in register 0x0D to ‘1’, depending upon if the I2C or SPI 4 wire or SPI 3 wire interface will be used for external communications. No data will appear in XOUT, YOUT and ZOUT registers if both the I2C_EN bit and SPI_EN bit and SPI3_EN bit are set to 0 (default).

When the FIFO is enabled, the output of the FIFO is mapped to registers 0x02 to 0x07, and the data has a maximum resolution of 12-bits.

During FIFO reads, software must start a read at address 0x02 and complete a read to address 0x07 for the FIFO pointers to increment correctly.

Once an I2C start bit has been recognized by the device, registers will not be updated until an I2C stop bit has occurred. Therefore, if software desires to read the low and high byte registers ‘atomically’, knowing that the values have not been changed, it should do so by issuing a start bit, reading one register, then reading the other register then issuing a stop bit. Note that all 6 registers may be read in one burst with the same effect.

Addr	Name	Description	Bit 7	Bit 6	Bit 5	Bit 4	Bit 3	Bit 2	Bit 1	Bit 0	POR Value	R/W
0x02	XOUT_LSB	XOUT LSB Register	XOUT [7]	XOUT [6]	XOUT [5]	XOUT [4]	XOUT [3]	XOUT [2]	XOUT [1]	XOUT [0]	0x00	R
0x03	XOUT_MSB	XOUT MSB Register	XOUT [15]	XOUT [14]	XOUT [13]	XOUT [12]	XOUT [11]	XOUT [10]	XOUT [9]	XOUT [8]	0x00	R
0x04	YOUT_LSB	YOUT LSB Register	YOUT [7]	YOUT [6]	YOUT [5]	YOUT [4]	YOUT [3]	YOUT [2]	YOUT [1]	YOUT [0]	0x00	R
0x05	YOUT_MSB	YOUT MSB Register	YOUT [15]	YOUT [14]	YOUT [13]	YOUT [12]	YOUT [11]	YOUT [10]	YOUT [9]	YOUT [8]	0x00	R
0x06	ZOUT_LSB	ZOUT LSB Register	ZOUT [7]	ZOUT [6]	ZOUT [5]	ZOUT [4]	ZOUT [3]	ZOUT [2]	ZOUT [1]	ZOUT [0]	0x00	R
0x07	ZOUT_MSB	ZOUT MSB Register	ZOUT [15]	ZOUT [14]	ZOUT [13]	ZOUT [12]	ZOUT [11]	ZOUT [10]	ZOUT [9]	ZOUT [8]	0x00	R

Table 15. XOUT, YOUT, ZOUT Data Output Registers



7.5 (0x08) Status Register 1

This register reports the operational mode of the device. Note that the lower 3-bits, the MODE[2:0] field, do not immediately change once a command is written to the MODE register, but may take up to 3 transitions of the heartbeat clock.

Addr	Name	Bit								POR Value	R/W
		7	6	5	4	3	2	1	0		
0x08	STATUS_1	INT_PEND	FIFO_THRESH	FIFO_FULL	FIFO_EMPTY	NEW_DATA	MODE[2]	MODE[1]	MODE[0]	00000000	RO

Bit	Name	Description		
[2:0]	MODE[2:0]	Bit Field	Mode	Comments
		000	SLEEP	Lowest power mode, regulators on, no clock activity, partial chip power-down
		001	STANDBY	Low power mode, no sampling, clocks active.
		010	SNIFF	Sniff activity detection mode, sniff enabled, sniff sampling, no FIFO operations, automatically transition to CWAKE mode upon activity detection
		011	RESV	Reserved
		100	RESV	Reserved
		101	CWAKE	Continuous wake. Active XYZ sampling. Sniff circuitry not active.
		110	SWAKE	Use Sniff logic, main XYZ pipeline and optional FIFO at the same time; highest power consumption



		111	TRIG	Trigger mode, 1 to 254 samples or continuous, return to sleep upon completion
3	NEW_DATA	0: No new sample data has arrived since last read. 1: New sample data has arrived and has been written to FIFO/registers. This bit is always enabled and valid, regardless of the settings of any interrupt enable bits.		
4	FIFO_EMPTY	0: FIFO has one or more samples in storage (level) 1: FIFO is empty (level) (default). This bit is set to 1 immediately after device power-up or device reset.		
5	FIFO_FULL	0: FIFO has space or 1 or more samples (up to 32) (level). 1: FIFO is full, all 32 samples are used (level).		
6	FIFO_THRESH	0: Amount of data in FIFO is less than the threshold (level) 1: Amount of data in FIFO is equal to or greater than the threshold (level)		
7	INT_PEND	0: No interrupt flags are pending in register 0x09 (level) 1: One or more interrupt flags are pending in register 0x09 (logical OR) (level).		

Table 16. Status Register 1 Settings



7.6 (0x09) Status Register 2

This register reports the state of the interrupts ('0' means not pending; '1' means pending). A bit in this register will only be set if the corresponding interrupt enable is set to '1' in (0x17) Interrupt Control Register. Interrupts can be cleared in the following ways using (0x0E) Feature Register 2 bit 4:

<u>Interface</u>	<u>Method</u>
I2C clearing method (default)	Read Register 0x09
I2C clearing method (optional)	Write Register 0x09
SPI clearing method	Write Register 0x09

Addr	Name	Bit								POR Value	R/W
		7	6	5	4	3	2	1	0		
0x09	STATUS_2	INT_SWAKE	INT_FIFO_THRESH	INT_FIFO_FULL	INT_FIFO_EMPTY	INT_ACQ	INT_WAKE	RESV	RESV	00000000	RO

Bit	Name	Description
[1:0]	Reserved	Reserved.
2	INT_WAKE	This interrupt will transition when the accelerometer automatically moves from SNIFF to CWAKE. Once cleared, another SNIFF to CWAKE event must take place to retrigger it.
3	INT_ACQ	This interrupt will transition when a new sample is acquired. This flag stays high upon the first sample acquired and will not rearm unless cleared. Only active in CWAKE and TRIG modes.
4	INT_FIFO_EMPTY	This interrupt will transition when the FIFO is empty. This flag stays high upon the first empty condition and will not rearm unless cleared. The FIFO empty condition must be negated (e.g. the FIFO must become 'not' empty), and then empty again for the INT_FIFO_EMPTY flag to retrigger.



5	INT_FIFO_FULL	This interrupt will transition when the FIFO is full (32 XYZ samples). This flag stays high upon the first full condition and will not rearm unless cleared. The FIFO full condition must be negated (e.g. the FIFO must become 'not' full), and then full again for the INT_FIFO_FULL flag to retrigger.
6	INT_FIFO_THRESH	This interrupt will transition when the FIFO sample count is equal to or greater than the threshold count 0x16[4:0]. This flag stays high upon the first threshold condition and will not rearm unless cleared.
7	INT_SWAKE	This interrupt will transition when the SNIFF block has detected an event only when the device is in SWAKE mode. Once an SWAKE interrupt is generated, the SNIFF block stops processing new events until the interrupt is cleared and the SNIFF block is reset. Optionally, the SNIFF block can be reset at the same time INT_SWAKE is cleared – see (0x0D) Feature Register 1 bit 4.

Table 17. Status Register 2 Settings



7.7 (0x0D) Feature Register 1

This register is used to select the interface mode as well as the operation style of the FIFO and interrupt in SWAKE mode.

NOTE: Software must set only one of the bits SPI_EN or I2C_EN or SPI3_EN in register 0x0D to '1', depending upon if the I2C or SPI 4 wire or SPI 3 wire interface will be used for external communications. No data will appear in XOUT, YOUT and ZOUT registers if both the I2C_EN bit and SPI_EN bit and SPI3_EN bit are set to 0 (default).

Addr	Name	Bit								POR Value	R/W
		7	6	5	4	3	2	1	0		
0x0D	FREG_1	SPI_EN	I2C_EN	SPI3_EN	INTSC_EN	FREEZE	0	0	0	00000000	RO

Bit	Name	Description
[2:0]	<Must write '000'>	Software must always write '000' to these 3 bits
3	FREEZE	<p>This bit is designed to be used with “FIFO stream mode” (register 0x0E bit 5) where the FIFO is configured to continuously capture new samples and flush the oldest after reaching a FIFO full state.</p> <p>0: FIFO operates in standard mode, does not stop capturing data in SWAKE interrupt (default).</p> <p>1: FIFO stops capturing on SWAKE interrupt, software can examine the conditions which generated the SWAKE event.</p>
4	INTSC_EN	<p>Once an SWAKE interrupt is generated, the SNIFF block stops processing new events until cleared. Enabling this bit allows the SNIFF block to be reset at the same time the INT_SWAKE interrupt is cleared.</p> <p>0: Do not re-arm SNIFF block following a SWAKE event (requires the SNIFF block to be reset by exiting SWAKE mode). (default)</p> <p>1: Clearing the SWAKE interrupt clears and rearms the SNIFF block for subsequent detections (device may stay in SWAKE mode and continuing</p>



		processing subsequent SWAKE events once interrupt is cleared).
5	SPI3_EN	0: SPI interface is 4-wire 1: SPI interface is 3-wire (DOUT_A1 is the bidirectional pin)
6	I2C_EN	0: Device interface is still defined as it was at power-up but no data will appear in XOUT, YOUT and ZOUT registers if both this bit and SPI_EN are set to 0 (default). 1: Disables any SPI communications.
7	SPI_EN	0: Device interface is still defined as it was at power-up but no data will appear in XOUT, YOUT and ZOUT registers if both this bit and I2C_EN are set to 0 (default). 1: Disables any I2C communications.

Table 18. Feature Register 1 Settings



7.8 **(0x0E) Feature Register 2**

This register allows selection of various features for the FIFO, external trigger input, method of interrupt clearing and burst address wrapping.

Addr	Name	Bit								POR Value	R/W
		7	6	5	4	3	2	1	0		
0x0E	FREG_2	EXT_TRIG_EN	EXT_TRIG_POL	FIFO_STREAM	I2CINT_WRCLE	FIFO_STAT_EN	SPI_STAT_EN	FIFO_BURST	WRAPA	00000000	RO

Bit	Name	Description
0	WRAPA	<p>Burst read address wrap control. This bit determines the “roll-back” or wrap address during burst reads. This bit works in I2C mode and both SPI modes.</p> <p>0: Burst read cycle address wrap address is 0x07, counter automatically returns to 0x02. (default)</p> <p>1: Burst read cycle address wrap address is 0x09, counter automatically returns to 0x02. This setting allows for status registers 0x08 and 0x09 to be included in the burst read.</p>
1	FIFO_BURST	<p>FIFO burst feature. This bit enables address increment logic which allows extended atomic burst reads of the FIFO greater than the standard 6-byte (3x16 bits) atomic burst read of XYZ data. This bit works in I2C mode and both SPI modes.</p> <p>0: FIFO burst read cycles are 6-bytes in length, 0x02 to 0x07 per read cycle transaction (default).</p> <p>1: FIFO burst read cycle can be any number of 6-byte reads, up to 32 x 6 bytes (i.e. the entire FIFO contents can be read).</p>



<p>2</p>	<p>SPI_STAT_EN</p>	<p>SPI 4-wire mode SPI status token.</p> <p>During the first SPI write cycle from the host, enabling this bit will cause the interface to send out system status information on the DOUT_A1 pin without requiring a separate read cycle. See 6.11 SPI Status Option.</p> <p>0: No SPI status flags are shifted out (default)</p> <p>1: SPI status flags are shifted out on the first byte of all 4-wire SPI transactions (SPI 3-wire and I2C modes are not supported, so no effect will be seen in those modes).</p>
<p>3</p>	<p>FIFO_STAT_EN</p>	<p>FIFO status token enable. This bit enables a 4-bit FIFO status token to be appended to the top 4 bits of the Z-channel data in every FIFO read cycle. This feature works in I2C mode and both SPI modes. When enabled, the format of the FIFO status token is:</p> <p>0: FIFO status feature is disabled, Z channel FIFO data is not overwritten with FIFO status information. (default)</p> <p>1: FIFO status feature is enabled. When the resolution is less than 14-bits, the top 4-bits of 16-bit Z channel FIFO data are replaced with FIFO status information:</p> <p>{[INT_PEND, FIFO_TH, FIFO_FULL, FIFO_EMPTY], Z[11:0]}</p> <p>When the resolution is 14-bits or above, the bottom 4-bits are replaced:</p> <p>{[Z[15:4], INT_PEND, FIFO_TH, FIFO_FULL, FIFO_EMPTY]}</p>



<p>4</p>	<p>I2CINT_WRCLRE</p>	<p>Clear interrupts on register 0x09 write in I2C mode. The default method of interrupt clearing is reading register 0x09, the INT_STATUS or STATUS_2 register. When this bit is enabled, reads to register 0x09 do not clear pending interrupts. SW must write to register 0x09 (contents do not matter) to clear any pending interrupts.</p> <p>NOTE: In SPI mode this bit has no effect; SPI interrupt clearing requires a write to register 0x09; reads are not supported.</p> <p>0: In I2C mode, interrupts are cleared when reading register 0x09 (default)</p> <p>1: if I2C_EN is '1', then interrupts are cleared when writing to register 0x09. Otherwise I2C reads to register 0x09 will still clear pending interrupts.</p>
<p>5</p>	<p>FIFO_STREAM</p>	<p>FIFO stream or “continuous” write mode. This bit enables the FIFO to be used as a moving sample buffer, discarding the oldest sample data when the FIFO is full and new sample data arrives. This is intended to work primarily with SWAKE mode, but CWAKE mode is also supported. Note that the FIFO_EN bit must be set to '1' for this bit to function. FIFO stream mode works in I2C mode and both SPI modes.</p> <p>0: FIFO steam mode is disabled, FIFO stops accepting new data when FULL (default)</p> <p>1: FIFO stream mode is enabled, FIFO discards oldest samples once new data arrives</p>
<p>6</p>	<p>EXT_TRIG_POL</p>	<p>External trigger polarity.</p> <p>0: Trigger polarity is negative edge triggered (default)</p> <p>1: Trigger polarity is positive edge triggered</p>
<p>7</p>	<p>EXT_TRIG_EN</p>	<p>External trigger mode enabled.</p> <p>0: External trigger mode is not enabled (default)</p> <p>1: External trigger mode is enabled, use INTN pin as the external trigger input.</p> <p>This mode is not used with the TRIG_CMD bit in Register 0x10 bit 7. To use this mode, set the TRIG mode in Register 0x10 bits [2:0].</p>

Table 19. Feature Register 2 Settings



7.9 **(0x0F) Initialization Register 1**

Software must write a fixed value to this register immediately after power-up or reset. This register will not typically read-back the value which was written (see below).

Addr	Name	Bit								POR Value	R/W
		7	6	5	4	3	2	1	0		
0x0F	INIT_1	0	1	0	0	0	0	1	0	(See note)	W

Note: During the internal chip start-up sequence, the read-back value will be 0x45. The read-back value will become 0x40 after the start-up sequence completes. After the initialization value of 0x42 is written, the read-back value will be 0x43.

Bit	Name	Description
[7:0]	INIT_1	Software must write a value of 0x42.

Table 20. Initialization Register 1 Settings



7.10 **(0x10) Mode Control Register**

This register is the primary control register for the accelerometer. The operational mode of the device, X/Y/Z axis enables, and the TRIG one-shot mode can be written through this register. The mode transitions controlled by this register may take up to 3 transitions of the heartbeat clock. Depending on the operation, the lower 3-bits (MCTRL[2:0]) may be automatically set or cleared by hardware if auto-triggered events are executed.

In general, when software sets an operational mode using the MCTRL [2:0] bits, there might be a delay time of 2 to 10 mSec before the operational mode is reflected by the MODE[2:0] bits in 0x08 Status Register 1.

Addr	Name	Description	Bit 7	Bit 6	Bit 5	Bit 4	Bit 3	Bit 2	Bit 1	Bit 0	POR Value	R/W
0x10	MODE_C	Mode Control	TRIG_CMD	Z_AXIS_PD	Y_AXIS_PD	X_AXIS_PD	RESV	MCTRL[2]	MCTRL[1]	MCTRL[0]	0x00	W

Bit	Name	Description		
[2:0]	MCTRL[2:0]	Bit Field	Mode	Comments
		000	SLEEP	Lowest power mode, regulators on, no clock activity, partial chip power-down.
		001	STANDBY	Low power mode, no sampling, clocks active.
		010	SNIFF	Sniff activity detection mode, sniff enabled, no sampling, no FIFO operations, automatically transition to CWAKE mode upon activity detection.
		011	Reserved	Reserved
		100	Reserved	Reserved
		101	CWAKE	Continuous wake. Active XYZ sampling. Sniff circuitry not active.



		110	SWAKE	Use Sniff logic, main XYZ pipeline and optional FIFO at the same time; highest power consumption
		111	TRIG	Trigger mode, 1 to 254 samples or continuous, return to sleep upon completion.
3	RESV	Reserved		
4	X_AXIS_PD	0: X-axis is enabled. 1: X-axis is disabled.		
5	Y_AXIS_PD	0: Y-axis is enabled. 1: Y-axis is disabled.		
6	Z_AXIS_PD	0: Z-axis is enabled. 1: Z-axis is disabled.		
7	TRIG_CMD	Setting this bit will execute a one-shot trigger mode where 1 to 254 samples are acquired (or the device will continuously sample if the value is 255). The number of samples is specified by the TRIG_COUNT in register 0x29. TRIG mode can only be started from STANDBY. Unless the value is 255, after the number of samples is completed, the device will return to STANDBY mode.		

Table 21. Mode Control Register Settings



7.11 (0x11) Rate Register 1

This register configures the sample rates for wake modes. The rates also depend upon the value in register 0x1C. The device has several power modes which can be adjusted to achieve a desired power consumption at a certain ODR. The tradeoff for lower power is either higher noise or lower ODR. See the table below.

NOTE: The power mode bits referenced in 0x1C are different than for the SNIFF rates.

Addr	Name	Bit								POR Value	R/W
		7	6	5	4	3	2	1	0		
0x11	RATE_1	RESV	MAN_SEL[2]	MAN_SEL[1]	MAN_SEL[0]	WR[3]	WR[2]	WR[1]	WR[0]	00000000	RW

Register 0x11 Value	Ultra-Low Power (0x1C[2:0]=>0x03)		Low Power (0x1C[2:0]=>0x00)		Precision (0x1C[2:0]=>0x04)	
	CWAKE ODR (Hz)	Current (µA)	CWAKE ODR (Hz)	Current (µA)	CWAKE ODR (Hz)	Current (µA)
0x05	n/a		14	1	14	5
0x06	25	0.9	28	1.6	28	10
0x07	50	1.6	54	2.7	55	18
0x08	100	2.8	105	5	80	25
0x09	190	5.5	210	11	n/a	
0x0A	380	10	400	19	n/a	
0x0B	750	18	600	26	n/a	
0x0C	1100	26	n/a		n/a	
0x0F*NOTE	1300	36	750	36	100	36

Table 22. Rate Register 1 Configuration

NOTE: Specific setup steps are required in order to set up Software Defined rate 0x11 = 0x0F (“Rate 15”).



Bit	Name	Description	
[3:0]	WR[3:0]	Bit Field	Comments
		XXXX	Sample rate discussed in Table 22 above.
[6:4]	MAN_SEL[2:0]	The manual select bits (MAN_SEL[2:0]) allow software to access shadow register 0x29. This addressing of 3 bits enables configuration of seven registers which are accessed to create a software defined rate for SNIFF and WAKE modes.	
		Address	Feature (accessed via 0x29)
		000	Manual rate mode disabled. Normal operation
		001	{SNIFF_RATE_IBTHC[3:0], WAKE_RATE_IBTHC[3:0]}
		010	{0,0,0, WAKE_RATE_FPICK[4:0]}
		011	{0,0,0, SNIFF_RATE_FPICK[4:0]}
		100	{WAKE_RATE_CLK_COUNT_LSB[7:0]}
		101	{WAKE_RATE_CLK_COUNT_MSB[15:8]}
		110	{SNIFF_RATE_CLK_COUNT_LSB[7:0]}
		111	{SNIFF_RATE_CLK_COUNT_MSB[15:8]}
7	RESV	Reserved	

Table 23. Rate Register 1 Settings



7.12 (0x12) Sniff Control Register

This register selects the sample rate for SNIFF mode and the clock rate for STANDBY mode.

NOTE: The power mode bits referenced in 0x1C are different than for the WAKE rates.

NOTE: Software must always write 0 to bit 4.

Addr	Name	Bit								POR Value	R/W
		7	6	5	4	3	2	1	0		
0x12	SNIFF_C	STB_RATE[2]	STB_RATE[1]	STB_RATE[0]	0	SNIFF_SR [3]	SNIFF_SR [2]	SNIFF_SR [1]	SNIFF_SR [0]	00000000	RW

Bit	Name	Description			
[3:0]	SNIFF_SR[3:0]	Approximate typical maximum clock rate when trigger count > 1 (Hz)			
		Bit Field	Ultra-Low Power (0x1C[6:4]=>0x03)	Low Power (0x1C[6:4]=>0x00)	Precision (0x1C[6:4]=>0x04)
		0000 (default)	6	7	7
		0001	0.4	0.4	0.2
		0010	0.8	0.8	0.4
		0011	1.5	1.5	0.9
		0100	6	7	7
		0101	13	14	14
		0110	25	28	28
		0111	50	54	55
		1000	100	105	80
		1001	190	210	n/a
		1010	380	400	n/a
		1011	750	600	n/a



		1100	1100	n/a	n/a
		1101	n/a	n/a	n/a
		1110	n/a	n/a	n/a
		1111 *NOTE	1300	750	100
4	0	Software must always write 0 to this bit.			
[7:5]	STB_RATE [2:0]	Approximate typical maximum clock rate when trigger count > 1 (Hz)			
		Bit Field	Ultra-Low Power (0x1C[6:4]=>0x03)	Low Power (0x1C[6:4]=>0x00)	Precision (0x1C[6:4]=>0x04)
		000 (default)	1	0.5	0.1
		001	3	1	0.2
		010	5	3	0.4
		011	10	6	0.8
		100	23	12	1.5
		101	45	24	3
		110	90	48	5
		111	180	100	10

Table 24. Sniff Control Register Settings



7.13 **(0x13) Sniff Threshold Control Register**

This register sets the threshold values used by the SNIFF logic for activity detection. For each axis, a delta count is generated and compared to the threshold. When the delta count is greater than the threshold, a SNIFF wakeup event occurs. There is a unique sniff threshold for each axis, and an optional “false detection count” which requires multiple sniff detection events to occur before a wakeup condition is declared. These features are set by six shadow registers accessed by register 0x13[5:0] and register 0x14 bits [2:0].

The SNIFF block supports the logical AND or OR of the X/Y/Z SNIFF wakeup flags when generating a SNIFF wakeup interrupt.

The SNIFF block supports two methods of calculating SNIFF delta counts:

- Current Sample to Previous Sample (C2P)
 - The current sample and the immediate previous sample are subtracted to generate a delta
- Current Sample to Baseline (C2B)
 - The current sample and the first sample captured when entering SNIFF mode are subtracted to generate a delta.

Addr	Name	Bit								POR Value	R/W
		7	6	5	4	3	2	1	0		
0x13	SNIFFTH_C	SNIFF_MODE	SNIFF_AND_OR	SNIFF_TH [5]	SNIFF_TH [4]	SNIFF_TH [3]	SNIFF_TH [2]	SNIFF_TH [1]	SNIFF_TH [0]	00000000	WS

Bit	Name	Description				
[5:0]	SNIFF_TH[5:0]	This 6-bit field accesses six shadow registers behind address 0x13. Register 0x14 bits [2:0] control which register is accessed.				
		<table border="1" style="width: 100%; text-align: center;"> <tr> <th>Reg 0x14</th> <th>Reg 0x13</th> </tr> <tr> <td>SNIFF_T_ADDR[2:0]</td> <td>SNIFF_TH[5:0]</td> </tr> </table>	Reg 0x14	Reg 0x13	SNIFF_T_ADDR[2:0]	SNIFF_TH[5:0]
		Reg 0x14	Reg 0x13			
		SNIFF_T_ADDR[2:0]	SNIFF_TH[5:0]			
000	None					
001	SNIFF Threshold, X-axis SNIFF_TH_X[5:0], unsigned threshold value 0 to 63 (independent from Y and Z thresholds).					



		010	<p>SNIFF Threshold, Y-axis</p> <p>SNIFF_TH_Y[5:0], unsigned threshold value 0 to 63 (independent from X and Z thresholds).</p>
		011	<p>SNIFF Threshold, Z-axis</p> <p>SNIFF_TH_Z[5:0], unsigned threshold value 0 to 63 (independent from X and Y thresholds).</p>
		100	None
		101	<p>SNIFF Detection Count, X-axis</p> <p>SNIFF_X_COUNT[5:0], unsigned SNIFF event count, 1 to 62 events, independent from other channels. The detection count is COUNT-1 for the desired number of events (for 1 event = 1-1 => 0 loaded into register).</p>
		110	<p>SNIFF Detection Count, Y-axis</p> <p>SNIFF_Y_COUNT[5:0], unsigned SNIFF event count, 1 to 62 events, independent from other channels. The detection count is COUNT-1 for the desired number of events (for 1 event = 1-1 => 0 loaded into register).</p>
		111	<p>SNIFF Detection Count, Z-axis</p> <p>SNIFF_Z_COUNT[5:0], unsigned SNIFF event count, 1 to 62 events, independent from other channels. The detection count is COUNT-1 for the desired number of events (for 1 event = 1-1 => 0 loaded into register).</p>



<p>6</p>	<p>SNIFF_AND_OR</p>	<p>Sets the logical mode for combining of X/Y/Z SNIFF wakeup events before an interrupt is generated. To remove one of the channels (axis) from the equation, use the corresponding axis PD bit in register 0x10 bits [6:4].</p> <p>0: OR - SNIFF wakeup/interrupt is triggered when any of the active channels have met detection threshold and count requirements (default).</p> $\text{Sniff Wakeup} = \Delta(\text{abs}(X) - X \text{ Sniff Threshold}) \text{ or } \Delta(\text{abs}(Y) - Y \text{ Sniff Threshold}) \text{ or } \Delta(\text{abs}(Z) - Z \text{ Sniff Threshold})$ <p>1: AND - SNIFF wakeup/interrupt is triggered when all active channels have met detection threshold and count requirements.</p> $\text{Sniff Wakeup} = \Delta(\text{abs}(X) - X \text{ Sniff Threshold}) \text{ and } \Delta(\text{abs}(Y) - Y \text{ Sniff Threshold}) \text{ and } \Delta(\text{abs}(Z) - Z \text{ Sniff Threshold})$
<p>7</p>	<p>SNIFF_MODE</p>	<p>This bit determines how the SNIFF block computes its delta count.</p> <p>0: C2P Mode (Current to Previous): The delta count between current and previous samples is a moving window. The SNIFF logic uses the current sample and the immediate previous sample to compute a delta (default).</p> <p>1: C2B Mode (Current to Baseline): The delta count is generated from subtracting the current sample from the first sample stored when entering SNIFF mode.</p>

Table 25. Sniff Threshold Control Register Settings



7.14 (0x14) Sniff Configuration Register

This register selects which of the six shadow registers is being accessed in register 0x13, and controls settings of the SNIFF hardware.

Addr	Name	Bit								POR Value	R/W
		7	6	5	4	3	2	1	0		
0x14	SNIFFCF_C	SNIFF_RESET	SNIFF_MUX[2]	SNIFF_MUX[1]	SNIFF_MUX[0]	SNIFF_CNTEN	SNIFF_THADR[2]	SNIFF_THADR[1]	SNIFF_THADR[0]	00000000	RW

Bit	Name	Description
[2:0]	SNIFF_THADR[2:0]	Bit Field
		Register selected by 0x13[5:0]
		000
		None
		001
		SNIFF Threshold, X-axis
		010
		SNIFF Threshold, Y-axis
		011
SNIFF Threshold, Z-axis		
3	SNIFF_CNTEN	None
		100
		None
101	SNIFF Detection Count, X-axis	SNIFF Detection Count, X-axis
		110
		SNIFF Detection Count, Y-axis
		111
		SNIFF Detection Count, Z-axis
[6:4]	SNIFF_MUX[2:0]	This field determines which 6-bits of the 11-bit delta count will be compared against the 6-bit threshold value for each channel. Clamp logic allows any SNIFF delta exceeding the selected 6-bit range to still be detected as a valid event. See examples below.



		Bit Field	Bit range selected
		000	DELTA[5:0]
		001	DELTA[6:1]
		010	DELTA[7:2]
		011	DELTA[8:3]
		100	DELTA[9:4]
		101	DELTA[10:5]
		110	DELTA[10:5]
		111	DELTA[10:5]
7	SNIFF_RESET	<p>This is the manual reset bit for the SNIFF block. This bit is not self-clearing, and can be used to re-enable the SNIFF block after a SNIFF event has been detected in SWAKE mode.</p> <p>0: SNIFF block reset is not applied (default). 1: SNIFF block reset is applied.</p>	

Table 26. Sniff Configuration Register Settings



7.15 **(0x15) Range and Resolution Control Register**

The RANGE register sets the resolution and range options for the accelerometer. All numbers are sign-extended, 2's complement format. All results are reported in registers 0x02 to 0x07.

When the FIFO is enabled, only 6 to 12-bit resolutions are supported due to the 12-bit width of the FIFO.

Addr	Name	Bit								POR Value	R/W
		7	6	5	4	3	2	1	0		
0x15	RANGE_C	RESV	RANGE [2]	RANGE [1]	RANGE [0]	RESV	RES[2]	RES[1]	RES[0]	00000000	RW

Bit	Name	Description	
[2:0]	RES[2:0]	Bit Field	Bit Width of Accelerometer Data
		000	6 bits
		001	7 bits
		010	8 bits
		011	10 bits
		100	12 bits
		101	14 bits (only 12-bits if FIFO enabled)
		110	Reserved
		111	Reserved
3	RESV	Reserved	
[6:4]	RANGE[2:0]	Bit Field	G Range Selection
		000	±2g
		001	±4g
		010	±8g



		011	±16g
		100	±12g
		101	Reserved
		110	Reserved
		111	Reserved
7	RESV	Reserved	

Table 27. Range and Resolution Control Register Settings



7.16 (0x16) FIFO Control Register

This register selects the FIFO threshold level, operation mode, FIFO reset and enable. With the exception of FIFO_RESET, the FIFO_EN bit must be '1' for any FIFO interrupts, thresholds, or modes to be enabled. The FIFO flags in register 0x08 will continue to report FIFO defaults even if the FIFO_EN is '0'.

Addr	Name	Bit								POR Value	R/W
		7	6	5	4	3	2	1	0		
0x16	FIFO_C	FIFO_RESET	FIFO_EN	FIFO_MODE	FIFO_TH [4]	FIFO_TH [3]	FIFO_TH [2]	FIFO_TH [1]	FIFO_TH [0]	00000000	RW

Bit	Name	Description
[4:0]	FIFO_TH[4:0]	The FIFO threshold level selects the number of samples in the FIFO for different FIFO events. The threshold value may be 1 to 31 (00001 to 11111).
5	FIFO_MODE	0: Normal operation, the FIFO continues to accept new sample data as long as there is space remaining (default) 1: Watermark, once the amount of samples in the FIFO reaches or exceeds the threshold level, the FIFO stops accepting new sample data. Any additional sample data is “dropped”.
6	FIFO_EN	FIFO enable control. All FIFO operations are gated by this bit. 0: No FIFO operation, sample data written directly to output registers. 1: FIFO enabled, all sample data written to FIFO write port if there is room. The FIFO write clock is controlled by this enable, resulting in higher dynamic power.
7	FIFO_RESET	Asynchronous FIFO reset. 0: FIFO reset is disabled, normal operation (default) 1: FIFO read and write pointers are cleared, FIFO contents returned to 0

Table 28. FIFO Control Register Settings



7.17 (0x17) Interrupt Control Register

Addr	Name	Bit								POR Value	RW
		7	6	5	4	3	2	1	0		
0x17	INTR_C	INT_SWAKE	INT_FIFO_THRESH	INT_FIFO_FULL	INT_FIFO_EMPTY	INT_ACQ	INT_WAKE	IAH	IPP	00000000	RW

Bit	Name	Description
0	IPP	INTN pin interrupt pin mode control. 0: INTN pin is configured for open-drain mode (external pullup to VDDIO required) (default). 1: INTN pin is configured for active drive or “push-pull” mode. Drive level is to VDDIO.
1	IAH	Interrupt level control, sets the active drive level of the INTN pin. 0: Interrupt request is active low (default). 1: Interrupt request is active high.
2	INT_WAKE	WAKE interrupt (SNIFF to WAKE) enable 0: No interrupt is generated when SNIFF activity is detected and the device auto-transitions to CWAKE mode (default). 1: Generate an interrupt when activity is detected in SNIFF mode and the device auto-transitions to CWAKE mode.
3	INT_ACQ	Interrupt on sample or acquisition enable 0: No interrupt generated when new sample data is acquired (default). 1: Generate an interrupt when new sample data is acquired (applies to new data written to output registers or FIFO). This enable is paired with the NEW_DATA flag in register 0x08.
4	INT_FIFO_EMPTY	FIFO empty interrupt enable. 0: No interrupt is generated when the FIFO is empty or completely drained of sample data (default). 1: Generate an interrupt when the FIFO is empty. This interrupt is paired with the FIFO_EMPTY flag in register 0x08. Note that this interrupt is independent of the FIFO threshold level, and will only activate when the FIFO sample count has reached a value of 0.



5	INT_FIFO_FULL	<p>FIFO full interrupt enable.</p> <p>0: No interrupt is generated when the FIFO is empty or completely filled of sample data (default).</p> <p>1: Generate an interrupt when the FIFO is full. This interrupt is paired with the FIFO_FULL flag in register 0x08. Note that this interrupt is independent of the FIFO threshold level, and will only activate when the FIFO sample count has reached a value of 32.</p>
6	INT_FIFO_THRESH	<p>FIFO threshold interrupt enable.</p> <p>0: No interrupt is generated when the FIFO threshold level is reached (default).</p> <p>1: Generate an interrupt when the FIFO threshold level is reached.</p>
7	INT_SWAKE	<p>This interrupt is valid only in SWAKE mode.</p> <p>0: No interrupt generated when SNIFF activity is detected (default).</p> <p>1: Generate an interrupt when SNIFF activity is detected.</p>

Table 29. Interrupt Control Register Settings



7.18 **(0x18) Chip ID Register**

This read only register reports the device ID of the device.

Addr	Name	Bit								POR Value	R/W
		7	6	5	4	3	2	1	0		
0x18	CHIP_ID	0	1	1	1	0	0	0	1	0x71	R



7.19 (0x1A) Initialization Register 3

Software must write a fixed value to this register immediately after power-up or reset.

Addr	Name	Bit								POR Value	R/W
		7	6	5	4	3	2	1	0		
0x1A	INIT_3	0	0	0	0	0	0	0	0	00000000	RW

Bit	Name	Description
[7:0]	INIT_3	Software must write '0' to these bits

Table 30. Initialization Register 3 Settings



7.20 (0x1B) Scratchpad Register

This register can store any 8-bit value and has no effect on hardware.

Addr	Name	Bit								POR Value	R/W
		7	6	5	4	3	2	1	0		
0x1B	SCRATCH	0	0	0	0	0	0	0	0	00000000	RW

Bit	Name	Description
[7:0]	SCRATCH	Any value can be written and read-back.

Table 31. Scratchpad Register



7.21 (0x1C) Power Mode Control Register

This register selects the power setting for CWAKE, SWAKE and SNIFF modes.

Addr	Name	Bit								POR Value	R/W	
		7	6	5	4	3	2	1	0			
0x1C	PMCR	SPI_HS_EN	SPM[2]	SPM[1]	SPM[0]	RESV	CSS	FF	SNM	CSPM[0]	00000000	RW

Bit	Name	Description
[2:0]	CSPM	CWAKE, SWAKE Power Mode 000: Low Power Mode (nominal noise levels) (default) 001: Reserved 010: Reserved 011: Ultra-Low Power Mode (highest noise levels) 100: Precision Mode (lowest noise levels) 101: Reserved 110: Reserved 111: Reserved
3	RESV	Reserved
[6:4]	SPM	SNIFF Power Mode 000: Low Power Mode (nominal noise levels) (default) 001: Reserved 010: Reserved 011: Ultra-Low Power Mode (highest noise levels) 100: Precision Mode (lowest noise levels) 101: Reserved 110: Reserved 111: Reserved



7	SPI_HS_EN	SPI High-Speed Enable 0: This bit will always return a '0' when read. Software must keep track of the state of this bit. Follow sequence from SPI High-Speed Enable Mode to enable high-speed SPI mode.
---	-----------	--

Table 32. Power Mode Control Register Settings



7.22 **(0x20) Drive Motion X Register**

This register controls the test mode which moves the sensor in the X axis direction and initializes specific hardware bits.

NOTE: Software must always write 0 to bits [7:4] and 1.

NOTE: Software must always write 1 to bit 0.

Addr	Name	Bit								POR Value	R/W
		7	6	5	4	3	2	1	0		
0x20	DMX	0	0	0	0	DNX	DPX	0	1	00000000	W

Bit	Name	Description
0	1	Reserved. Always write 1 to this bit
1	0	Reserved. Always write 0 to this bit.
2	DPX	0: Disabled (default) 1: Move the sensor in X Positive direction
3	DNX	0: Disabled (default) 1: Move the sensor in X Negative direction
[7:4]	0000	Reserved. Always write 0 to these bits.

Table 33. Drive Motion X Register Settings



7.23 **(0x21) Drive Motion Y Register**

This register controls the test mode which moves the sensor in the Y axis direction and initializes specific hardware bits.

NOTE: Software must always write 0 to bits [6:4] and [1:0].

NOTE: Software must always write 1 to bit 7 after writing to register 0x20[0].

Addr	Name	Bit								POR Value	R/W
		7	6	5	4	3	2	1	0		
0x21	DMY	1	0	0	0	DNY	DPY	0	0	(See table)	RW

Mode (MCTLR[2:0] bits in MODE_C Register 0x10)	Read-back Value
SNIFF, CWAKE, SWAKE, TRIG	0x80
SLEEP, STANDBY	0x00

Table 34. Register 0x21 Read-Back Value

Bit	Name	Description
[1:0]	00	Reserved. Always write 0 to these bits.
2	DPY	0: Disabled (default) 1: Move the sensor in Y Positive direction
3	DNY	0: Disabled (default) 1: Move the sensor in Y Negative direction
[6:4]	000	Reserved. Always write 0 to these bits.
7	1	Reserved. Always write 1 to this bit.

Table 35. Drive Motion Y Register Settings



7.24 (0x22) Drive Motion Z Register

This register controls the test mode which moves the sensor in the Z axis direction.

NOTE: Software must always write 0 to bits [7:4] and [1:0].

Addr	Name	Bit								POR Value	R/W
		7	6	5	4	3	2	1	0		
0x22	DMZ	0	0	0	0	DNZ	DPZ	0	0	00000000	RW

Bit	Name	Description
[1:0]	00	Reserved. Always write 0 to these bits.
2	DPZ	0: Disabled (default) 1: Move the sensor in Z Positive direction
3	DNZ	0: Disabled (default) 1: Move the sensor in Z Negative direction
[7:4]	0000	Reserved. Always write 0 to these bits.

Table 36. Drive Motion Z Register Settings



7.25 **(0x24) Reset Register**

This register can be used to reset the device. Anytime there is a reset to the device, a POR event, or a power cycle the SPI 3-wire configuration will reset to 4-wire mode.

Addr	Name	Bit								POR Value	R/W
		7	6	5	4	3	2	1	0		
0x24	RESET	RELOAD	RESET	RESV	RESV	RESV	RESV	RESV	RESV	00000000	RW

Bit	Name	Description
[5:0]	Reserved	Reserved
6	RESET	0: Normal operation (default) 1: Force a power-on-reset (POR) sequence. OTP contents are reloaded into registers, AOFS contents are decompressed, and any other registers are returned to their default. This bit is self-clearing.
7	RELOAD	0: Normal operation (default) 1: Reloads the registers from OTP. A RELOAD operation enables OTP core for reading, performs a complete read of OTP into the register file, and then disables the OTP. Use register 0x01 bit 5 to monitor the OTP_BUSY bit. This bit must be cleared by software

Table 37. Reset Register Settings



7.26 (0x28) Initialization Register 2

Software must write a fixed value to this register immediately after power-up or reset.

Addr	Name	Bit								POR Value	R/W
		7	6	5	4	3	2	1	0		
0x28	INIT_2	0	0	0	0	0	0	0	0	00000000	RW

Bit	Name	Description
[7:0]	INIT_2	Software must write '0' to these bits

Table 38. Initialization Register 2 Settings



7.27 (0x29) Trigger Count Register/SDR configuration

This register selects the number of samples to be taken after the one-shot trigger is started.

Addr	Name	Bit								POR Value	R/W
		7	6	5	4	3	2	1	0		
0x29	TRIGC	TRIGC[7]	TRIGC[6]	TRIGC[5]	TRIGC[4]	TRIGC[3]	TRIGC[2]	TRIGC[1]	TRIGC[0]	00000000	WS

Bit	Name	Description
[7:0]	TRIGC[7:0]	<p>Non-Software Defined rate (default)</p> <p>Selects the number of samples to be captured after the one-shot trigger is started. Range from 1 to 254. When value 255 is chosen, the device will run continuously until the mode in register 0x10 is changed.</p> <p>Software Defined rate</p> <p>Shadow register accessible via Rate Register 1 (0x11[6:4]). Please refer to register 0x11 definition.</p>

Table 39. Trigger/Software Defined Rate Register Settings



7.28 (0x2A – 0x2B) X-Axis Offset Registers

This register contains a signed 2’s complement 15-bit value applied as an offset adjustment to the output of the acceleration values, prior to being sent to the OUT_EX registers. The Power-On-Reset value for each chip is unique and is set as part of factory calibration. If necessary, this value can be overwritten by software.

NOTE: When modifying these registers with new gain or offset values, software should perform a read-modify-write type of access to ensure that unrelated bits do not get changed inadvertently.

Addr	Name	Bit 7	Bit 6	Bit 5	Bit 4	Bit 3	Bit 2	Bit 1	Bit 0	POR Value	R/W
0x2A	XOFFL	XOFF[7]	XOFF[6]	XOFF[5]	XOFF[4]	XOFF[3]	XOFF[2]	XOFF[1]	XOFF[0]	Per chip	W
0x2B	XOFFH	XGAIN[8]	XOFF[14]	XOFF[13]	XOFF[12]	XOFF[11]	XOFF[10]	XOFF[9]	XOFF[8]	Per chip	W

Table 40. X-Axis Offset Registers



7.29 **(0x2C – 0x2D) Y-Axis Offset Registers**

This register contains a signed 2’s complement 15-bit value applied as an offset adjustment to the output of the acceleration values, prior to being sent to the OUT_EX registers. The Power-On-Reset value for each chip is unique and is set as part of factory calibration. If necessary, this value can be overwritten by software.

NOTE: When modifying these registers with new gain or offset values, software should perform a read-modify-write type of access to ensure that unrelated bits do not get changed inadvertently.

Addr	Name	Bit 7	Bit 6	Bit 5	Bit 4	Bit 3	Bit 2	Bit 1	Bit 0	POR Value	R/W
0x2C	YOFFL	YOFF[7]	YOFF[6]	YOFF[5]	YOFF[4]	YOFF[3]	YOFF[2]	YOFF[1]	YOFF[0]	Per chip	W
0x2D	YOFFH	YGAIN[8]	YOFF[14]	YOFF[13]	YOFF[12]	YOFF[11]	YOFF[10]	YOFF[9]	YOFF[8]	Per chip	W

Table 41. Y-Axis Offset Registers



7.30 (0x2E – 0x2F) Z-Axis Offset Registers

This register contains a signed 2’s complement 15-bit value applied as an offset adjustment to the output of the acceleration values, prior to being sent to the OUT_EX registers. The Power-On-Reset value for each chip is unique and is set as part of factory calibration. If necessary, this value can be overwritten by software.

NOTE: When modifying these registers with new gain or offset values, software should perform a read-modify-write type of access to ensure that unrelated bits do not get changed inadvertently.

Addr	Name	Bit 7	Bit 6	Bit 5	Bit 4	Bit 3	Bit 2	Bit 1	Bit 0	POR Value	R/W
0x2E	ZOFFL	ZOFF[7]	ZOFF[6]	ZOFF[5]	ZOFF[4]	ZOFF[3]	ZOFF[2]	ZOFF[1]	ZOFF[0]	Per chip	W
0x2F	ZOFFH	ZGAIN[8]	ZOFF[14]	ZOFF[13]	ZOFF[12]	ZOFF[11]	ZOFF[10]	ZOFF[9]	ZOFF[8]	Per chip	W

Table 42. Z-Axis Offset Registers



7.31 (0x2B & 0x30) X-Axis Gain Registers

The gain value is an unsigned 9-bit number.

NOTE: When modifying these registers with new gain or offset values, software should perform a read-modify-write type of access to ensure that unrelated bits do not get changed inadvertently.

Addr	Name	Bit 7	Bit 6	Bit 5	Bit 4	Bit 3	Bit 2	Bit 1	Bit 0	POR Value	R/W
0x2B	XOFFH	XGAIN[8]	XOFF[14]	XOFF[13]	XOFF[12]	XOFF[11]	XOFF[10]	XOFF[9]	XOFF[8]	Per chip	W
0x30	XGAIN	XGAIN[7]	XGAIN[6]	XGAIN[5]	XGAIN[4]	XGAIN[3]	XGAIN[2]	XGAIN[1]	XGAIN[0]	Per chip	W

Table 43. X-Axis Gain Registers



7.32 (0x2D & 0x31) Y-Axis Gain Registers

The gain value is an unsigned 9-bit number.

NOTE: When modifying these registers with new gain or offset values, software should perform a read-modify-write type of access to ensure that unrelated bits do not get changed inadvertently.

Addr	Name	Bit 7	Bit 6	Bit 5	Bit 4	Bit 3	Bit 2	Bit 1	Bit 0	POR Value	R/W
0x2D	YOFFH	YGAIN[8]	YOFF[14]	YOFF[13]	YOFF[12]	YOFF[11]	YOFF[10]	YOFF[9]	YOFF[8]	Per chip	W
0x31	YGAIN	YGAIN[7]	YGAIN[6]	YGAIN[5]	YGAIN[4]	YGAIN[3]	YGAIN[2]	YGAIN[1]	YGAIN[0]	Per chip	W

Table 44. Y-Axis Gain Registers



7.33 (0x2F & 0x32) Z-Axis Gain Registers

The gain value is an unsigned 9-bit number.

NOTE: When modifying these registers with new gain or offset values, software should perform a read-modify-write type of access to ensure that unrelated bits do not get changed inadvertently.

Addr	Name	Bit 7	Bit 6	Bit 5	Bit 4	Bit 3	Bit 2	Bit 1	Bit 0	POR Value	R/W
0x2F	ZOFFH	ZGAIN[8]	ZOFF[14]	ZOFF[13]	ZOFF[12]	ZOFF[11]	ZOFF[10]	ZOFF[9]	ZOFF[8]	Per chip	W
0x32	ZGAIN	ZGAIN[7]	ZGAIN[6]	ZGAIN[5]	ZGAIN[4]	ZGAIN[3]	ZGAIN[2]	ZGAIN[1]	ZGAIN[0]	Per chip	W

Table 45. Z-Axis Gain Registers



8 Index of Tables

Table 1. Order Information	5
Table 2. Pin Description	9
Table 3. Absolute Maximum Ratings.....	16
Table 4. Sensor Characteristics	17
Table 5. Electrical Characteristics – Voltage and Current	18
Table 6. Electrical Characteristics – Interface	19
Table 7. I2C Timing Characteristics	20
Table 8. SPI Interface Timing Parameters	21
Table 9. Recommended Initialization Sequence	23
Table 10. Operational Modes.....	24
Table 11. I2C Address Selection.....	26
Table 12. Register Summary	34
Table 13. Extended Status Register 1 Settings	35
Table 14. Extended Status Register 2 Settings.....	36
Table 15. XOUT, YOUT, ZOUT Data Output Registers.....	37
Table 16. Status Register 1 Settings.....	39
Table 17. Status Register 2 Settings.....	41
Table 18. Feature Register 1 Settings.....	43
Table 19. Feature Register 2 Settings.....	46
Table 20. Initialization Register 1 Settings	47
Table 21. Mode Control Register Settings.....	49
Table 22. Rate Register 1 Configuration	50
Table 23. Rate Register 1 Settings	51
Table 24. Sniff Control Register Settings	53
Table 26. Sniff Threshold Control Register Settings.....	56
Table 27. Sniff Configuration Register Settings.....	58
Table 28. Range and Resolution Control Register Settings	60
Table 29. FIFO Control Register Settings	61
Table 30. Interrupt Control Register Settings	63
Table 31. Initialization Register 3 Settings	65
Table 32. Scratchpad Register.....	66
Table 33. Power Mode Control Register Settings.....	68



Table 34. Drive Motion X Register Settings..... 69

Table 35. Register 0x21 Read-Back Value 70

Table 36. Drive Motion Y Register Settings..... 70

Table 37. Drive Motion Z Register Settings..... 71

Table 38. Reset Register Settings 72

Table 39. Initialization Register 2 Settings 73

Table 40. Trigger/Software Defined Rate Register Settings 74

Table 41. X-Axis Offset Registers 75

Table 42. Y-Axis Offset Registers 76

Table 43. Z-Axis Offset Registers 77

Table 44. X-Axis Gain Registers 78

Table 45. Y-Axis Gain Registers 79

Table 46. Z-Axis Gain Registers 80



9 Revision History

Date	Revision	Description
2016-01	APS-048-0047v1.0	First release.
2016-02	APS-048-0047v1.1	Updated 5.3 initialization sequence. Updated Rate 15 sequences for CWAKE and SNIFF.
2016-07	APS-048-0047v1.2	Updated shadow registers, SPI mode, Application Circuits, manual osc. mode varying.
2017-07	APS-048-0047v1.3	Added soldering profile, shipping and handling guidelines, moisture sensitivity level control, and SPI high-speed mode sections, updated SPI interface speed, and added high-speed bit description to register 0x1C. Updated Offset, Cx and TCS typical performance.



10 Legal

1. M-CUBE reserves the right to make corrections, modifications, enhancements, improvements and other changes to its products and to this document at any time and discontinue any product without notice. The information contained in this document has been carefully checked and is believed to be accurate. However, M-CUBE shall assume no responsibilities for inaccuracies and make no commitment to update or to keep current the information contained in this document.
2. M-CUBE products are designed only for commercial and normal industrial applications and are not suitable for other purposes, such as: medical life support equipment; nuclear facilities; critical care equipment; military / aerospace; automotive; security or any other applications, the failure of which could lead to death, personal injury or environmental or property damage. Use of the products in unsuitable applications are at the customer's own risk and expense.
3. M-CUBE shall assume no liability for incidental, consequential or special damages or injury that may result from misapplication or improper use of operation of the product.
4. No license, express or implied, by estoppel or otherwise, to any intellectual property rights of M-CUBE or any third party is granted under this document.
5. M-CUBE makes no warranty or representation of non-infringement of intellectual property rights of any third party with respect to the products. M-CUBE specifically excludes any liability to the customers or any third party regarding infringement of any intellectual property rights, including the patent, copyright, trademark or trade secret rights of any third party, relating to any combination, machine, or process in which the M-CUBE products are used.
6. Examples of use described herein are provided solely to guide use of M-CUBE products and merely indicate targeted characteristics, performance and applications of products. M-CUBE shall assume no responsibility for any intellectual property claims or other problems that may result from applications based on the examples described herein
7. Information described in this document including parameters, application circuits and its constants and calculation formulas, programs and control procedures are provided for the purpose of explaining typical operation and usage. "Typical" parameters that may be provided in M-CUBE data sheets and/or specifications can and do vary in different applications and actual performance may vary over time. All operating parameters including "Typicals," must be validated for each customer application by customer's technical experts. In no event shall the information described be regarded as a guarantee of conditions or characteristics of the products. Therefore, the customer should evaluate the design sufficiently as whole system under the consideration of various external or environmental conditions and determine their application at the customer's own risk. M-CUBE shall assume no responsibility or liability for claims, damages, costs and expenses caused by the customer or any third party, owing to the use of the above information.



M-CUBE and the M-CUBE logo are trademarks of M-CUBE, Inc.,

All other product or service names are the property of their respective owners.

© M-CUBE, Inc. 2017. All rights reserved.



Mouser Electronics

Authorized Distributor

Click to View Pricing, Inventory, Delivery & Lifecycle Information:

[mCube:](#)

[MC3630](#)