

MAX1709

4A, Low-Noise, High-Frequency, Step-Up DC-DC Converter

General Description

The MAX1709 sets a new standard of space savings for high-power, step-up DC-DC conversion. It delivers up to 20W at a fixed (3.3V or 5V) or adjustable (2.5V to 5.5V) output, using an on-chip power MOSFET from a +0.7V to +5V supply.

Fixed-frequency PWM operation ensures that the switching noise spectrum is constrained to the 600kHz fundamental and its harmonics, allowing easy postfiltering for noise reduction. External clock synchronization capability allows for even tighter noise spectrum control. Quiescent power consumption is less than 1mW to extend operating time in battery-powered systems.

Two control inputs (ON \overline{A} , \overline{ONB}) allow simple push-on, push-off control through a single momentary pushbutton switch, as well as conventional on/off logic control. The MAX1709 also features programmable soft-start and current limit for design flexibility and optimum performance with batteries.

The MAX1709 is supplied in both a high-power TSSOP package, which allows a 10ARMS switch current and a 4A output, and a narrow SO package, which supplies a 2.4A output with a switch rated at 6ARMS. Although the narrow SO device has a lower RMS switch rating, it has the same peak switch current rating as the TSSOP device, and so can supply 4A loads intermittently. If loads of 2A or less are required, refer to the MAX1708.

Applications

- Routers, Servers, Workstations, Card Racks
- Local 2.5V to 3.3V or 5V Conversion
- Local 3.3V to 5V Conversion
- 3.6V or 5V RF PAs in Communications Handsets

Typical Operating Circuit

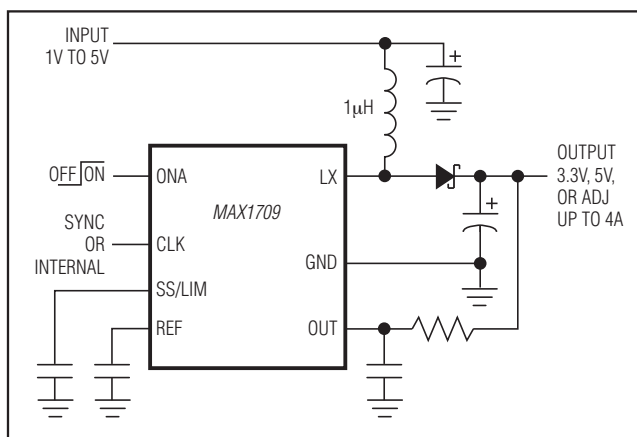

Benefits and Features

- Integration Reduces External Component Count to Save Space
 - On-Chip 10A Power MOSFET
 - 5V, 4A Output from a 3.3V Input
 - Fixed 3.3V or 5V Output Voltage or Adjustable (2.5V to 5.5V)
 - Input Voltage Range Down to 0.7V
- Constant Frequency Reduces Post-Filtering
 - Low-Noise, Constant-Frequency Operation (600kHz)
 - Synchronizable Switching Frequency (350kHz to 1000kHz)
- Lower Power Consumption Extends Battery Life
 - 1mW Quiescent Power

Ordering Information

PART	TEMP RANGE	PIN-PACKAGE
MAX1709ESE	-40°C to +85°C	16 Narrow SO
MAX1709EUI+	-40°C to +85°C	28 TSSOP-EP*

+Denotes a lead(Pb)-free/RoHS-compliant package.

*EP = Exposed pad.

Pin Configuration

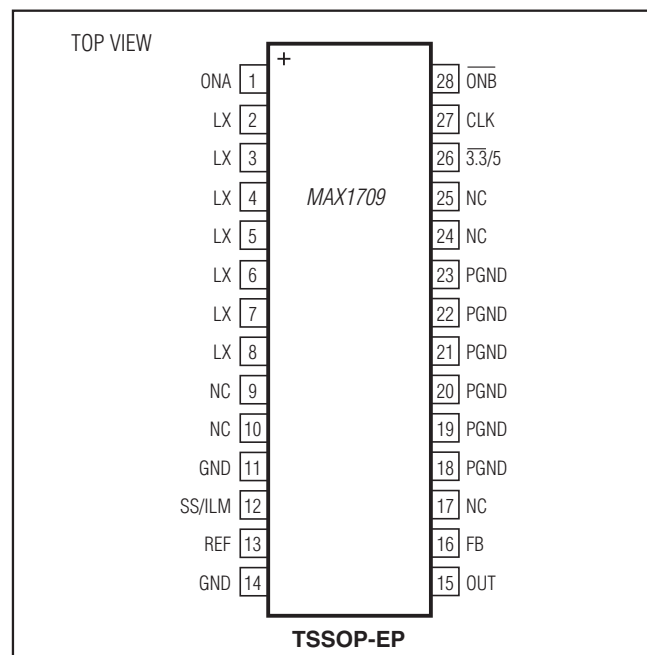

Absolute Maximum Ratings

ONA, $\overline{\text{ONB}}$, OUT, SS/LIM, 3.3/5 to GND -0.3V to +6.0V
 LX to PGND -0.3V to +6.0V
 FB, CLK, REF to GND -0.3V to (V_{OUT} + 0.3V)
 PGND to GND -0.3V to +0.3V
 Continuous Power Dissipation (T_A = +70°C)
 16-Pin Narrow SO (derate 16.5mW/°C above +70°C) 1.3W
 28-Pin TSSOP Exposed Pad
 (derate 23.8mW/°C above +70°C) 1.9W

28-Pin TSSOP Exposed Pad Junction-to-Exposed
 Pad Thermal Resistance 1.2°C/W
 Operating Temperature Range -40°C to +85°C
 Junction Temperature +150°C
 Storage Temperature Range -65°C to +150°C
 Lead Temperature (soldering, 10s) +300°C

Stresses beyond those listed under "Absolute Maximum Ratings" may cause permanent damage to the device. These are stress ratings only, and functional operation of the device at these or any other conditions beyond those indicated in the operational sections of the specifications is not implied. Exposure to absolute maximum rating conditions for extended periods may affect device reliability.

Electrical Characteristics

(V_{OUT} = V_{CLK} = +3.6V, ONA = $\overline{\text{ONB}}$ = FB = GND, T_A = 0°C to +85°C, unless otherwise noted. Typical values are at T_A = +25°C.)

PARAMETER	CONDITIONS	MIN	TYP	MAX	UNITS	
Output Voltage	V _{FB} < 0.1V (Note 1)	$\overline{3.3}/5 = \text{GND}$, I _{SW} = 1A	3.26	3.34	3.42	V
		$\overline{3.3}/5 = \text{OUT}$, I _{SW} = 1A	4.92	5.05	5.17	
Load Regulation	Measured between 1A < I _{SW} < 3A (Note 2)		-0.25	-0.45	%/A	
FB Regulation Voltage	I _{SW} = 1A	1.215	1.240	1.265	V	
FB Input Current	V _{FB} = +1.5V		1	200	nA	
Output Voltage Adjust Range		2.5		5.5	V	
Output Undervoltage Lockout	(Note 3)	2.0		2.3	V	
Frequency in Startup Mode	V _{OUT} = 1.5V	40		400	kHz	
Minimum Startup Voltage	I _{OUT} < 1mA (Note 1), T _A = +25°C (Note 4)		0.9	1.1	V	
Minimum Operating Voltage	(Note 5)		0.7		V	
Soft-Start Pin Current	V _{SS/LIM} = 1V	3.2	4	5.0	μA	
OUT Supply Current	V _{FB} = 1.5V (Note 6)		200	440	μA	
OUT Leakage Current In Shutdown	V $\overline{\text{ONB}}$ = 3.6V		0.1	5	μA	
LX Leakage Current	V _{LX} = V $\overline{\text{ONB}}$ = V _{OUT} = +5.5V		0.1	40	μA	
n-Channel Switch On-Resistance			22	40	mΩ	
n-Channel Current Limit	SS/LIM = open	7.5	9	12	A	
	SS/LIM = 150kΩ to GND	3.5	5	6.5		
RMS Switch Current	MAX1709EUI+			10	A _{RMS}	
	MAX1709ESE			6		
Reference Voltage	I _{REF} = 0	1.245	1.260	1.275	V	
Reference Load Regulation	-1μA < I _{REF} < 50μA		4	10	mV	
Reference Supply Rejection	+2.5V < V _{OUT} < +5.5V		0.2	5	mV	
Input Low Level (Note 7)	ONA, $\overline{\text{ONB}}$, $\overline{3.3}/5$, 1.2V < V _{OUT} < 5.5V			0.2 × V _{OUT}	V	
	CLK, 2.7V < V _{OUT} < 5.5V			0.2 × V _{OUT}		

Electrical Characteristics (continued)(V_{OUT} = V_{CLK} = +3.6V, ONA = $\overline{\text{ONB}}$ = FB = GND, T_A = 0°C to +85°C, unless otherwise noted. Typical values are at T_A = +25°C.)

PARAMETER	CONDITIONS	MIN	TYP	MAX	UNITS
Input High Level	ONA, $\overline{\text{ONB}}$, $\overline{3.3/5}$, 1.2V < V _{OUT} < 5.5	0.8 × V _{OUT}			V
	CLK, 2.7 V < V _{OUT} < 5.5V	0.8 × V _{OUT}			
Logic Input Current	ONA, $\overline{\text{ONB}}$, CLK, $\overline{3.3/5}$	1			μA
Internal Oscillator Frequency		520	600	680	kHz
Maximum Duty Cycle		82	90	94	%
External Clock Frequency Range		350		1000	kHz
CLK Pulse Width	(Note 8)	100			ns
CLK Rise/Fall Time	(Note 8)			50	ns

Electrical Characteristics(V_{OUT} = V_{CLK} = +3.6V, ONA = $\overline{\text{ONB}}$ = FB = GND, T_A = -40°C to +85°C, unless otherwise noted.) (Note 9)

PARAMETER	CONDITIONS		MIN	TYP	MAX	UNITS
Output Voltage	V _{FB} < 0.1V, V _{IN} = +2.4V	$\overline{3.3/5}$ = GND, I _{SW} = 1A	3.24		3.45	V
	(Note 1)	$\overline{3.3/5}$ = OUT, I _{SW} = 1A	4.9		5.2	
FB Regulation Voltage	I _{SW} = 1A		1.21		1.27	V
FB Input Current	V _{FB} = +1.5V				200	nA
Load Regulation	Measured between 1A < I _{SW} < 5A (Note 2)				-0.45	%/A
Soft-Start Pin Current	SS/LIM = 1V		3.2		5.2	μA
OUT Leakage Current in Shutdown	V $\overline{\text{ONB}}$ = 3.6V				5	μA
OUT Supply Current	V _{FB} = 1.5V (Note 6)				400	μA
n-Channel Switch On-Resistance					40	mΩ
n-Channel Current Limit	SS/LIM = unconnected		7.5		15	V
	SS/LIM = 150kΩ to GND		3.5		7	
Reference Voltage	I _{REF} = 0		1.24		1.28	V

Electrical Characteristics (continued)(V_{OUT} = V_{CLK} = +3.6V, ONA = $\overline{\text{ONB}}$ = FB = GND, T_A = -40°C to +85°C, unless otherwise noted.) (Note 9)

PARAMETER	CONDITIONS	MIN	TYP	MAX	UNITS
Input Low Level (Note 7)	ONA, $\overline{\text{ONB}}$, $\overline{3.3/5}$, 1.2V < V _{OUT} < 5.5V			0.2 × V _{OUT}	V
	CLK, 2.7V < V _{OUT} < 5.5V			0.2 × V _{OUT}	
Input High Level	ONA, $\overline{\text{ONB}}$, $\overline{3.3/5}$, 1.2V < V _{OUT} < 5.5V	0.8 × V _{OUT}			V
	CLK, V _{OUT} = 5.5V	0.8 × V _{OUT}			
Logic Input Current	ONA, $\overline{\text{ONB}}$, CLK, $\overline{3.3/5}$			1	μA
Internal Oscillator Frequency		500		700	kHz
Maximum Duty Cycle		80		95	%
External Clock Frequency Range		350		1000	kHz
CLK/SEL Pulse Width	(Note 8)	100			ns
CLK/SEL Rise/Fall Time	(Note 8)			50	ns

Note 1: Output voltage is specified at 1A switch current I_{SW}, which is equivalent to approximately 1A × (V_{IN} / V_{OUT}) of load current.**Note 2:** Load regulation is measured by forcing specified switch current and straight-line calculation of change in output voltage in external feedback mode. Note that the equivalent load current is approximately I_{SW} × (V_{IN} / V_{OUT}).**Note 3:** Until undervoltage lockout is reached, the device remains in startup mode. Do not apply full load until this voltage is reached.**Note 4:** Startup is tested with Figure 1's circuit. Output current is measured when both the input and output voltages are applied.**Note 5:** Minimum operating voltage. The MAX1709 is bootstrapped and will operate down to a 0.7V input once started.**Note 6:** Supply current is measured from the OUT pin to the output voltage (+3.3V). This correlates directly with actual input supply current but is reduced in value according to the step-up ratio and efficiency.**Note 7:** ONA and $\overline{\text{ONB}}$ inputs have approximately 0.15V hysteresis.**Note 8:** Guaranteed by design, not production tested.**Note 9:** Specifications to -40°C are guaranteed by design, not production tested.

Typical Operating Characteristics

($T_A = +25^\circ\text{C}$, unless otherwise noted.)

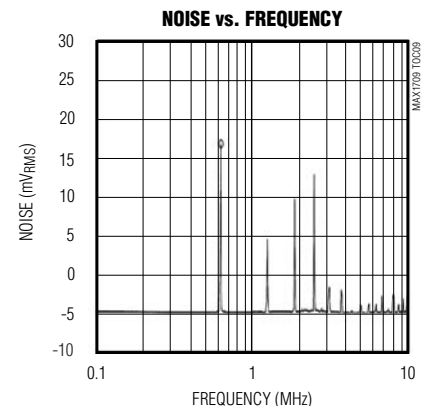
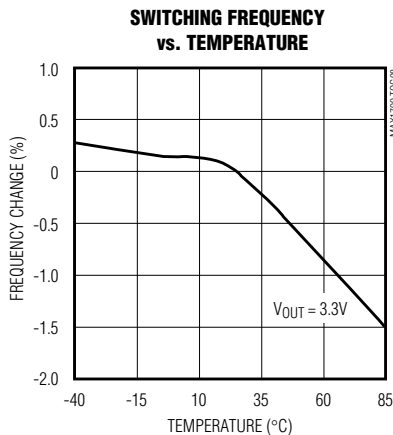
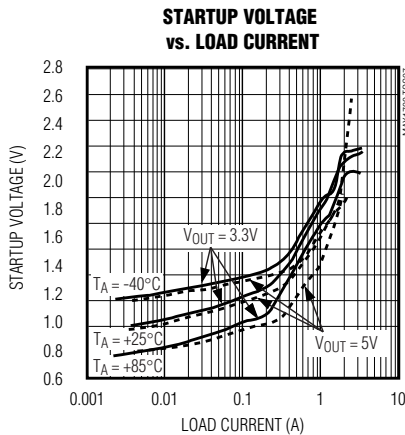
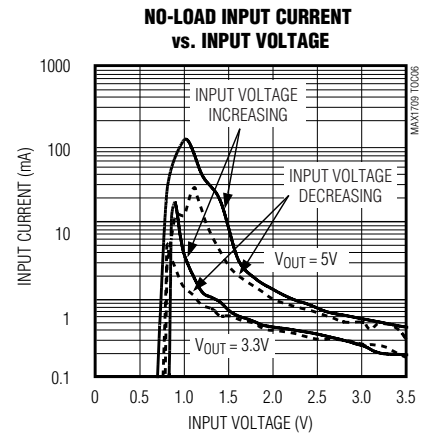
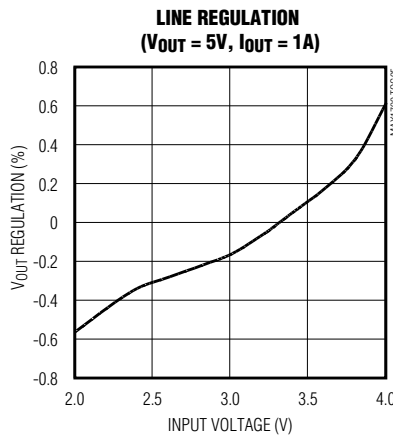
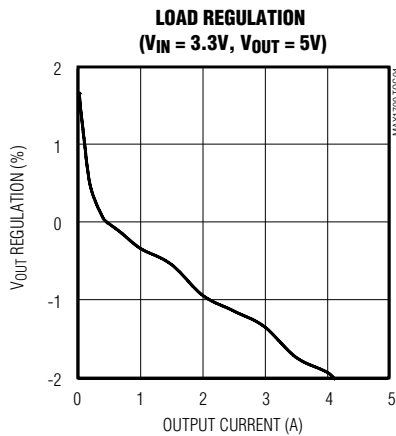
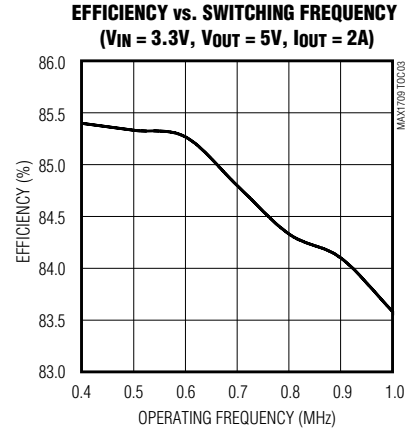
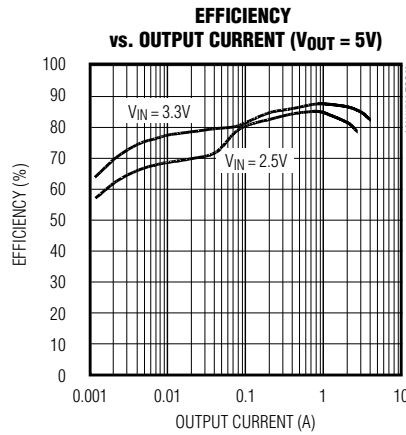
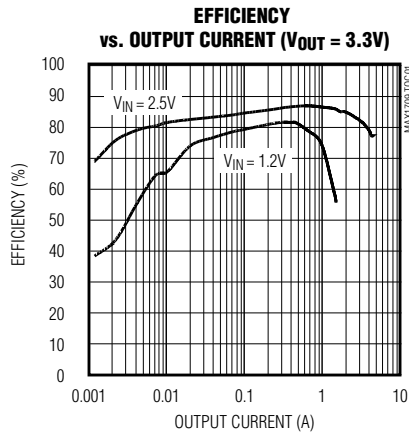

Typical Operating Characteristics (continued)

($T_A = +25^\circ\text{C}$, unless otherwise noted.)

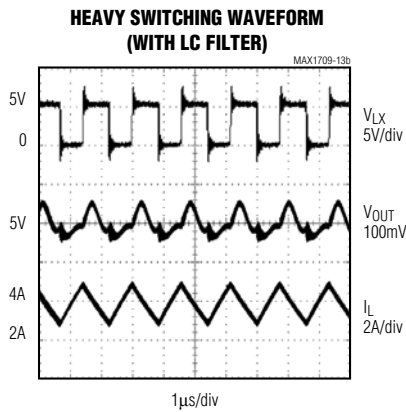
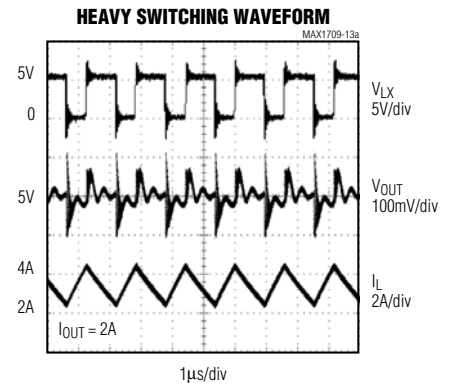
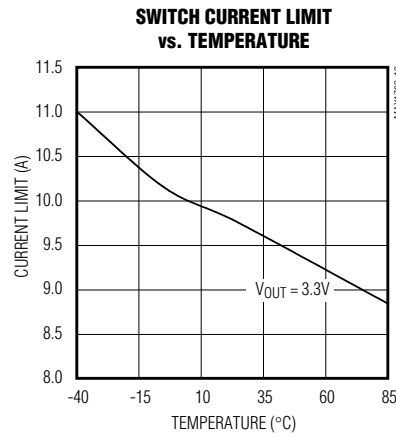
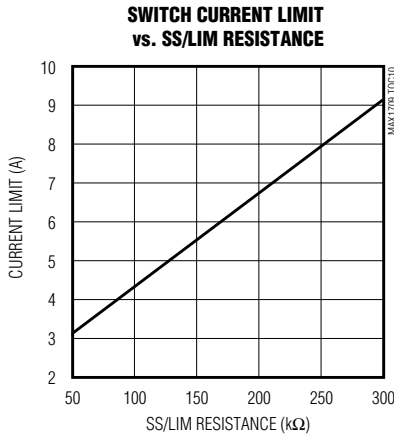

$I_{OUT} = 2A$
 $L = 12.5nH$ (COILCRAFT A04T)
 $C = 1\mu F$

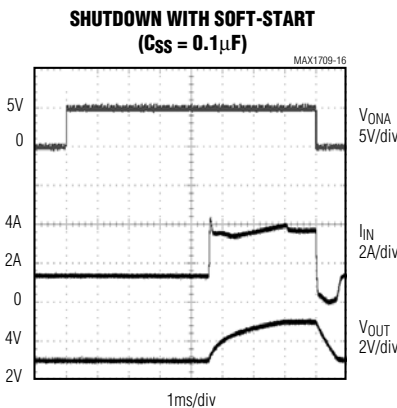
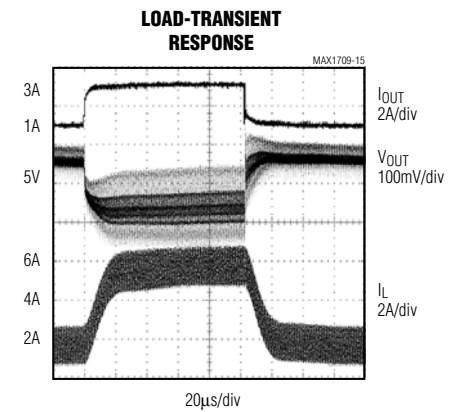
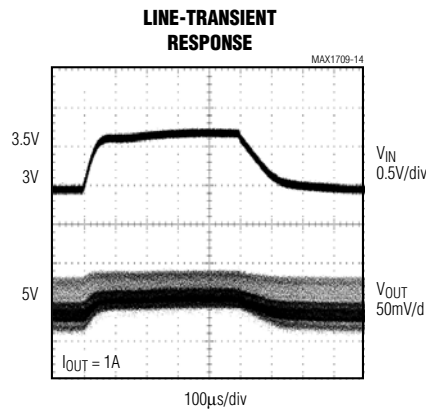

$C_{SS} = 0.1\mu F$
 $R_{OUT} = 5\Omega$
 $V_{ONB} = V_{OUT}$

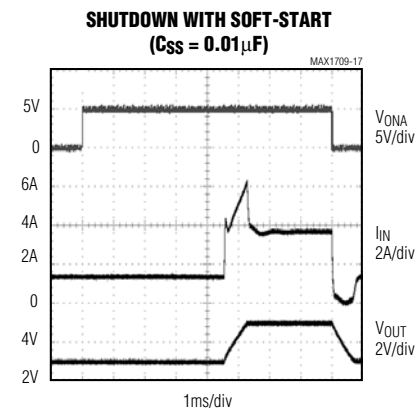

$C_{SS} = 0.01\mu F$
 $R_{OUT} = 5\Omega$
 $V_{ONB} = V_{OUT}$

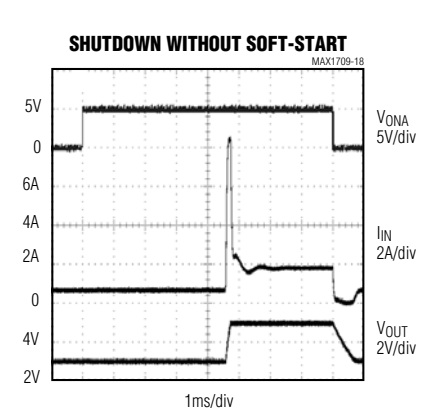

$C_{SS} = 0$
 $R_{OUT} = 5\Omega$
 $V_{ONB} = V_{OUT}$

Pin Description

PIN		NAME	FUNCTION
TSSOP	NARROW SO		
1	1	ONA	On-Control Input. When ONA = high OR $\overline{\text{ONB}}$ = low, the device turns on
2–8	2, 3, 4	LX	Drain of n-Channel Power Switch. Connect pins 2, 3, and 4 together. Connect external Schottky diode from LX to OUT.
11, 14	5, 8	GND	Ground. Connect ground inputs together, then connect to PGND.
12	6	SS/LIM	Soft-Start and/or Current-Limit Input. Connect a capacitor from SS/LIM to GND to control the rate at which the device reaches current limit (soft-start). To reduce the current limit from the preset values, connect a resistor from SS/LIM to GND (see <i>Design Procedure</i>). During shutdown, this pin is internally pulled to GND to discharge the soft-start capacitor.
13	7	REF	1.26V Voltage Reference Output. Bypass with a 0.22 μ F capacitor to GND. Maximum REF load is 50 μ A.
15	9	OUT	Output Voltage Sense Input. The device is powered from OUT. Bypass with a 0.1 μ F to PGND with less than 5mm trace length. Connect a 2 Ω series resistor from the output filter capacitor to OUT (Figure 1).
16	10	FB	DC-DC Converter Feedback Input. Connect FB to GND for internally set output voltage (see $\overline{3.3}/5$ pin description). Connect a resistor-divider from the output to set the output voltage in the +2.5V to +5.5V range. FB regulates to +1.25V (Figure 4).
18–23	11, 12, 13	PGND	Power Ground. Source of n-channel power MOSFET switch. Connect PGND inputs together, then connect to GND.
26	14	$\overline{3.3}/5$	Output Voltage Selection Pin. When FB is connected to GND, the regulator uses internal feedback to set the output voltage. $\overline{3.3}/5$ = low sets output to 3.3V; $\overline{3.3}/5$ = high sets output to 5V. If an external divider is used at FB, connect $\overline{3.3}/5$ to ground.
27	15	CLK	Clock Input for the DC-DC Converter. Connect to OUT for internal oscillator. Optionally, drive with an external clock for external synchronization.
28	16	$\overline{\text{ONB}}$	Shutdown Input. When $\overline{\text{ONB}}$ = high AND ONA = low, the device turns off (Table 1).
9, 10, 17, 24, 25	—	N.C.	No Connect. Not internally connected.
EP	—	EP	Exposed Pad. Connect to large ground plane for maximum thermal dissipation.

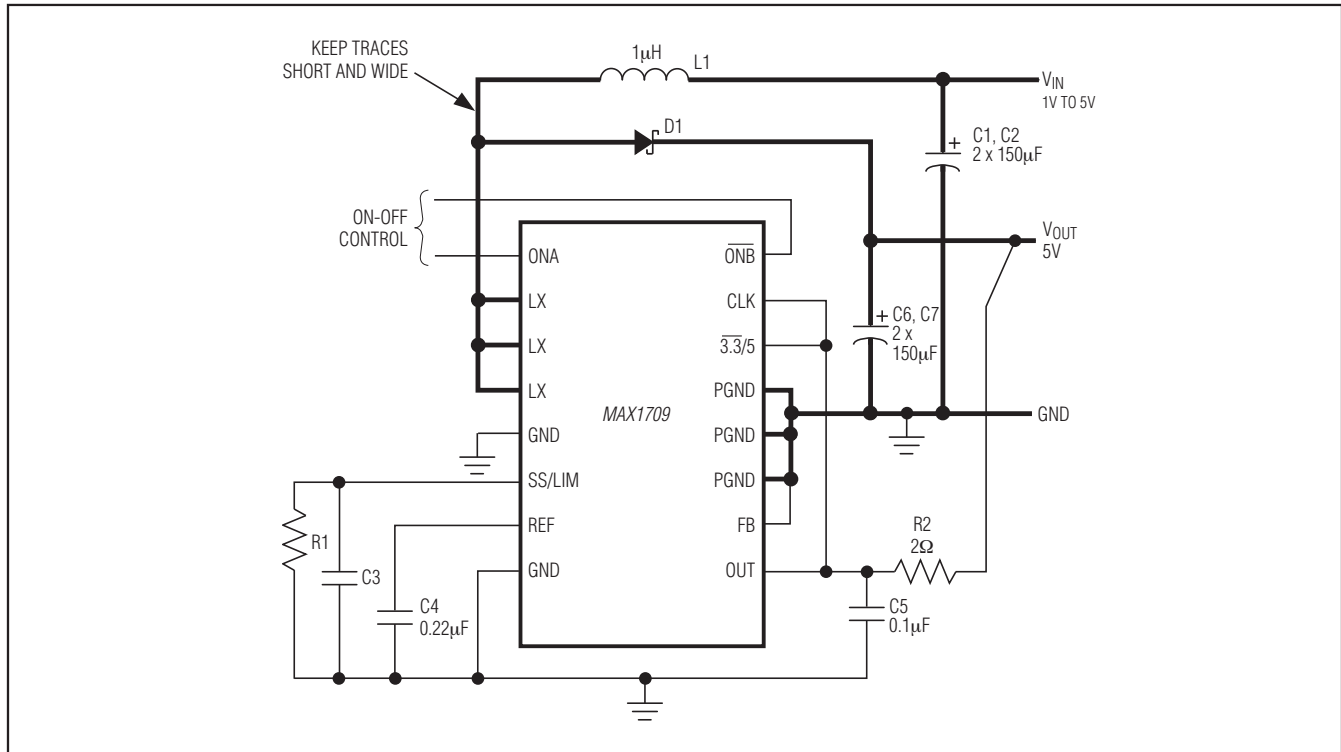

Figure 1. Standard Operating Circuit

Detailed Description

The MAX1709 step-up converter offers high efficiency and high integration for high-power applications. It operates with an input voltage as low as 0.7V and is suitable for single- to 3-cell battery inputs as well as 2.5V or 3.3V regulated supply inputs. The output voltage is preset to +3.3V or +5.0V or can be adjusted with external resistors for voltages between +2.5V to +5.5V.

The n-channel switch of the MAX1709EUI+ is rated for 10A_{RMS} and can deliver loads up to 4A, depending on input and output voltage. The n-channel switch of the MAX1709ESE has a 6A_{RMS} rating and supplies up to 2.4A output. The MAX1709ESE has a lower RMS switch rating than the MAX1709EUI+, but has the same peak switch current limit and so can supply 4A loads intermittently. For flexibility, the current limit and soft-start rate are independently programmable.

A 600kHz switching frequency allows for a small inductor to be used. The switching frequency is also synchronizable to an external clock ranging from 350kHz to 1000kHz.

ONA, $\overline{\text{ONB}}$

The logic levels at ONA and $\overline{\text{ONB}}$ turn the MAX1709 on or off. When ONA = 1 or $\overline{\text{ONB}}$ = 0, the part is on. When ONA = 0 and $\overline{\text{ONB}}$ = 1, the part is off (Table 1). Logic-high on control can be implemented by tying $\overline{\text{ONB}}$ high and using ONA for shutdown. Implement inverted single-line on/off control by grounding ONA and toggling $\overline{\text{ONB}}$. Implement momentary pushbutton On/Off as described in the *Applications Information* section. Both inputs have approximately 0.15V of hysteresis.

Switching Frequency

The MAX1709 switches at the fixed-frequency internal oscillator rate (600kHz) or can be synchronized to an external clock. Connect CLK to OUT for internal clock operation. Apply a clock signal to CLK to synchronize to an external clock. The frequency can be changed on the fly. The MAX1709 will synchronize to a new external clock rate in two cycles and will take approximately 40µs to revert to its internal clock frequency once the external clock pulses stop and CLK is driven high. Table 2 summarizes oscillator operation.

Table 1. On/Off Logic Control

ONA	ONB	MAX1709
0	0	On
0	1	Off
1	0	On
1	1	On

Table 2. Selecting Switching Frequency

CLK	MODE
0	Not allowed
1	PWM
External clock (350kHz–1000kHz)	Synchronized PWM

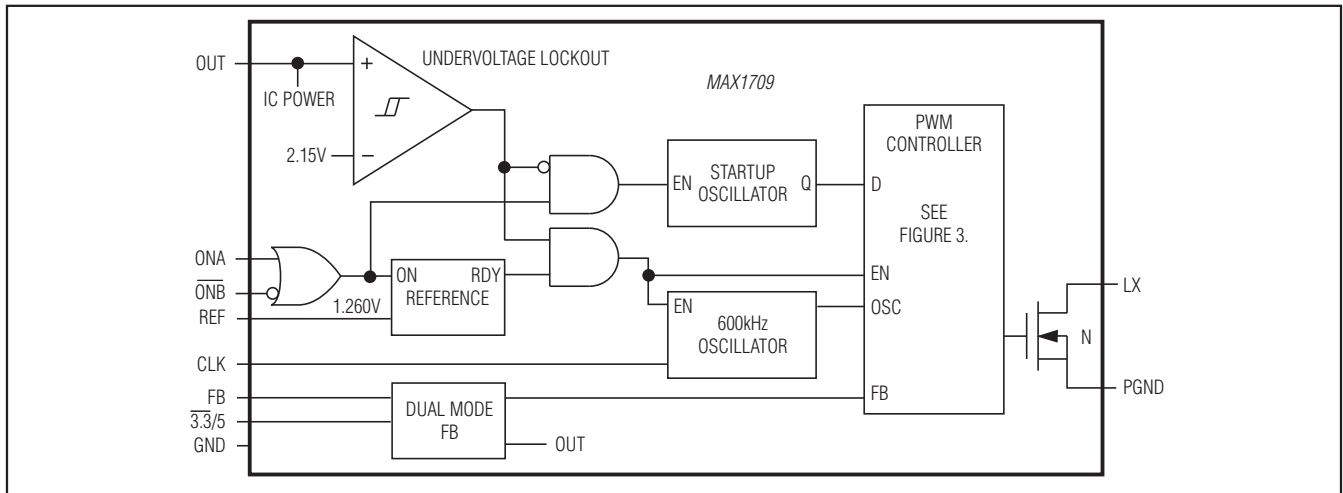

Figure 2. Simplified Functional Diagram

Operation

The MAX1709 switches at a constant frequency (600kHz) and modulates the MOSFET switch pulse width to control the power transferred per cycle and regulate the voltage across the load. In low-noise applications, the fundamental and the harmonics generated by the fixed switching frequency are easily filtered out. Figure 2 shows the simplified functional diagram for the MAX1709. Figure 3 shows the simplified PWM controller functional diagram. The MAX1709 enters synchronized current-mode PWM when a clock signal (350kHz < f_{CLK} < 1000kHz) is applied to CLK. For wireless or noise-sensitive applications, this ensures that switching harmonics are predictable and kept outside the IF frequency band(s). High-frequency operation permits low-magnitude output ripple voltage and minimum inductor and filter capacitor size. Switching losses will increase at the higher frequencies (see *Power Dissipation*).

Setting the Output Voltage

The MAX1709 features Dual-Mode™ operation. When FB is connected to ground, the MAX1709 generates a fixed output voltage of either +3.3V or +5V, depending

Dual Mode is a trademark of Maxim Integrated Products, Inc.

on the logic applied to the 3.3/5 input (Figure 1). The output can be configured for other voltages, using two external resistors as shown in Figure 4. To set the output voltage externally, choose an R3 value that is large enough to minimize load at the output but small enough to minimize errors due to leakage and the time constant to FB. A value of R3 ≤ 50kΩ is required.

$$R4 = R3 \left(\frac{V_{OUT}}{V_{FB}} - 1 \right)$$

where V_{FB} = 1.24V.

Soft-Start/Current-Limit Adjustment (SS/LIM)

The soft-start pin allows the soft-start time to be adjusted by connecting a capacitor from SS/LIM to ground. Select capacitor C3 (connected to SS/LIM pin) as:

$$C3 \text{ (in } \mu\text{F)} = 3.2 \times t_{SS}$$

where t_{SS} is the time (in seconds) it takes the switch current limit to reach full value.

To improve efficiency or reduce inductor size at reduced load currents, the current limit can be reduced

Table 3. Component Selection Guide

PRODUCTION	INDUCTORS	CAPACITORS	DIODES
Surface mount	Coilcraft DO3316P-102HC	Panasonic EEFUE0J151R	Motorola MBRD1035CTL
	Coiltronics UP2B-1R0	Sanyo 6TPC100M	STM-Microelectronics STPS8L30B

Table 4. Component Suppliers

SUPPLIER	PHONE	FAX
Coilcraft	847-639-6400	847-639-1489
Coiltronics	561-241-7876	561-241-9339
Motorola	602-303-5454	602-994-6430
Panasonic	714-373-7939	714-373-7183
STM-Microelectronics	617-259-0300	617-259-9442

from its nominal value (see *Electrical Characteristics*). A resistor (R1 in Figure 1) between SS/LIM and ground reduces the current limit as follows:

$$R1 = 312.5k\Omega \times \frac{I_1}{I_{LIM}} \quad (R1 \leq 312.5k\Omega)$$

where I_1 is the desired current limit in amperes, and I_{LIM} is the current limit value from the *Electrical Characteristics*.

Design Procedure

Inductor Selection (L1)

The MAX1709's high switching frequency allows the use of a small-size inductor. Use a 1.0μH inductor for 600kHz operation. If the MAX1709 will be synchronized

at a different frequency, scale the inductor value with the inverse of frequency ($L_1 = 1\mu H \times 600kHz / f_{SYNC}$). The PWM design tolerates inductor values within ±25% of this calculated value, so choose the closest standard inductor value. For example, use 1.5μH for 350kHz and 0.68μH for 1MHz.

Inductors with a ferrite core or equivalent are recommended; powder iron cores are not recommended for use at high switching frequencies. Ensure the inductor's saturation rating (the current at which the core begins to saturate and inductance falls) exceeds the internal current limit. Note that this current may be reduced through SS/LIM if less than the MAX1709's full load current is needed (see *Electrical Characteristics* for ratings). For highest efficiency, use a coil with low DC resistance, preferably under 10mΩ. To minimize radiated noise, use a toroid, pot core, or shielded inductor. See Tables 3 and 4 for a list of recommended components and component suppliers. To calculate the maximum output current (in amperes), use the following equation:

$$I_{OUT(MAX)} = D' \left(I_{LIM} - D' \left(\frac{V_{OUT} + V_D - V_{IN}}{2 \times f \times L1} \right) \right)$$

where:
 V_{IN} = input voltage

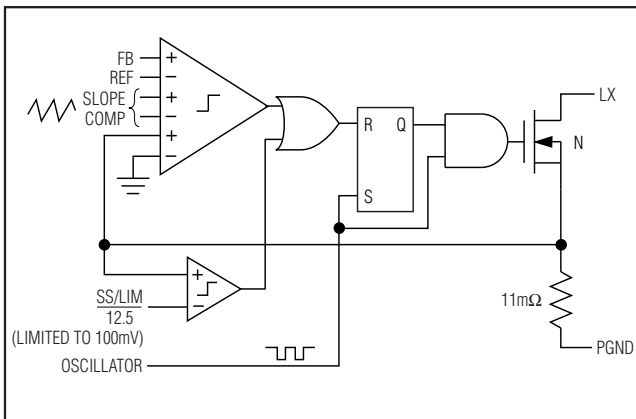

Figure 3. Simplified PWM Controller Functional Diagram

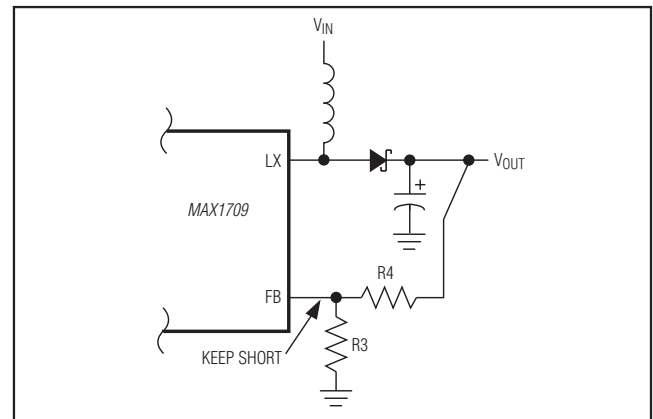

Figure 4. Adjustable Output Voltage

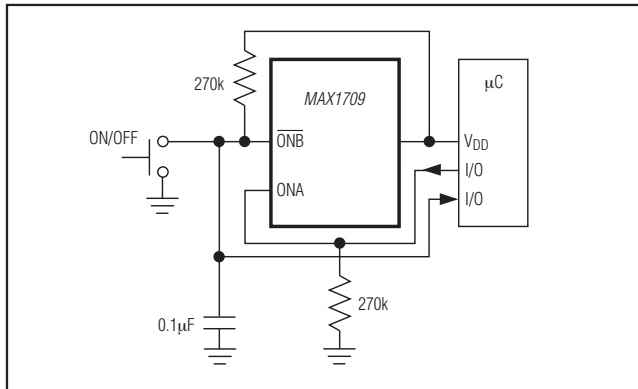

Figure 5. Momentary Pushbutton On-Off Switch

V_D = forward voltage drop of the Schottky diode at I_{LIM} current

V_{OUT} = output voltage

$D' = (V_{IN}) / (V_{OUT} + V_D)$, assuming switch voltage drop is negligible

f = switching frequency

$L1$ = inductor value

I_{LIM} = minimum value of switch current limit from *Electrical Characteristics* or set by $R_{SET/LIM}$.

Diode Selection (D1)

The MAX1709's high switching frequency demands a high-speed rectifier. Schottky diodes, such as the MBRD1035CTL or STPS8L30B (Table 3), are recommended. The diode's current rating must exceed the maximum load current, and its breakdown voltage must exceed V_{OUT} . The diode must be placed within 10mm of the LX switching node and the output filter capacitor. The diode also must be able to dissipate the power calculated by the following equation:

$$P_{DIODE} = I_{OUT} \times V_D$$

where I_{OUT} is the average load current and V_D is the diode forward voltage at the peak switch current.

Capacitor Selection

Input Bypass Capacitors (C1, C2)

Two 150µF, low-ESR tantalum input capacitors will reduce peak currents and reflected noise due to inductor current ripple. Lower ESR allows for lower input ripple current, but combined ESR values up to 50mΩ are acceptable. Smaller ceramic capacitors may also be used for light loads or in applications that can tolerate higher input current ripple.

Output Filter Capacitors (C6, C7)

The output filter capacitor ESR must be kept under 15mΩ for stable operation. Two parallel 150µF polymer capacitors (Panasonic EEFUE0J151R) typically exhibit 5mΩ of ESR. This translates to approximately 35mV of output ripple at 7A switch current. Bypass the MAX1709 IC supply input (OUT) with a 0.1µF ceramic capacitor to GND and connect a 2Ω series resistor to OUT (R2, as shown in Figure 1).

Power Dissipation

The MAX1709 output current may be more limited by package power dissipation than by the current rating of the on-chip switch. For pulsed loads, output currents of 4 Amps or more can be supplied with either the MAX1709EUI+ or MAX1709ESE, but the RMS (or thermal) limit of the MAX1709ESE is lower (6ARMS) than that of the MAX1709EUI+ (10ARMS). Continuous output current depends on the input and output voltage, operating temperature, and external components.

The major components of the MAX1709 dissipated power (P_D , i.e., power dissipated as heat in the IC and NOT delivered to the load) are:

- 1) Internal switch conduction losses - P_{SW}
- 2) Internal switch transition losses - P_{TRAN}
- 3) Internal capacitive losses - P_{CAP}

These are losses that directly dissipate heat in the MAX1709, but keep in mind that other losses, such as those in the external diode and inductor, increase input power by reducing overall efficiency, and so indirectly contribute to MAX1709 heating.

Approximate equations for the loss terms are as follows. Values in {} are example values for a 3.3V input, 4V output, 4A design.

A conservative efficiency estimate for the MAX1709 boosting from 3.3V to 5V at 4A is 81%. Total estimated power loss is then:

$$P_{LOSS} = (P_{OUT} / 0.81) - P_{OUT} \quad \{4.7W\}$$

The total loss consists of:

$$\text{Diode Loss} = D' \times I_{SW} \times V_D \quad \{2.5W\}$$

$$\text{Inductor Loss (resistive loss + dynamic loss estimate)} \quad \{0.58W\}$$

$$\text{External Capacitive Loss} = (1 - D') \times I_{SW}^2 \times R_{CAP-ESR} \quad \{0.27W\}$$

$$\text{MAX1709 Internal Loss, } P_{D(\text{MAX1709})} \quad \{1.35W\}$$

MAX1709

4A, Low-Noise, High-Frequency, Step-Up DC-DC Converter

Approximate equations for the MAX1709 internal loss terms are as follows. Values in {} are example values for a 3.3V input, 4V output, 4A design:

$$P_{D(\text{MAX1709})} = P_{\text{SW}} + P_{\text{TRAN}} + P_{\text{CAP}} \quad \{1.35\text{W}\}$$

where:

$$P_{\text{SW}} = (1 - D') \times I_{\text{SW}}^2 \times R_{\text{SW}} \quad \{1.08\text{W}\}$$

$$P_{\text{TRAN}} = (V_{\text{OUT}} + V_{\text{D}}) \times I_{\text{SW}} \times \frac{t_{\text{SW}} \times f}{3} \quad \{0.18\text{W}\}$$

$$P_{\text{CAP}} = (C_{\text{DIO}} + C_{\text{DSW}} + C_{\text{GSW}}) \times (V_{\text{OUT}} + V_{\text{D}})^2 \times f \quad \{0.09\text{W}\}$$

where:

$$D' = \text{duty factor of the n-channel switch} = \frac{V_{\text{IN}}}{(V_{\text{OUT}} + V_{\text{D}})} \quad \{0.6\}$$

(Note: $D' = 1$ means the switch is always off)

$$I_{\text{SW}}, \text{ the approximate peak switch current} = \frac{I_{\text{OUT}}}{(D' \times \text{eff})}, \quad \{8.23\text{A}\}$$

(with eff. estimated at 81%)

$$R_{\text{SW}} = \text{Internal n-channel switch resistance} \quad \{0.04\text{W}\}$$

(estimate for elevated die temperature)

$$V_{\text{D}} = \text{forward voltage of the external rectifier} \quad \{0.5\text{V}\}$$

$$t_{\text{SW}} = \text{the transition time of the n-channel switch} \quad \{20\text{ns}\}$$

$$f = \text{the switching rate of the MAX1709} \quad \{600\text{kHz}\}$$

$$C_{\text{DIO}} = \text{rectifier capacitance} \quad \{1\text{nF}\}$$

$$C_{\text{DSW}} = \text{internal n-channel drain capacitance} \quad \{2.5\text{nF}\}$$

$$C_{\text{GSW}} = \text{internal n-channel gate capacitance} \quad \{1.5\text{nF}\}$$

Applications Information

Using a Momentary On/Off Switch

A momentary pushbutton switch can be used to turn the MAX1709 on and off. As shown in Figure 5, when ONA is pulled low and $\overline{\text{ONB}}$ is pulled high, the part is off. When the momentary switch is pressed, $\overline{\text{ONB}}$ is pulled low and the regulator turns on. The switch should be on long enough for the microcontroller to exit reset. The controller issues a logic high to ONA, which guarantees that the part will stay on regardless of the subsequent switch state. To turn the regulator off, press the switch long enough for the controller to read the switch status and pull ONA low. When the switch is released, $\overline{\text{ONB}}$ pulls high and the regulator turns off.

Layout Considerations

The MAX1709ESE and MAX1709EUI+ both utilize PC board area for heatsinking. Package dissipation ratings in the *Absolute Maximum Ratings* section assume 1in² of 1oz copper.

The MAX1709EUI+ has superior power-dissipating ability due to an exposed metal pad on the underside of the package. The thermal resistance from the die to the exposed pad is a very low 1.2°C/W. The MAX1709ESE's ability to dissipate power will especially depend on the PC board design. Typical thermal resistance for 1in² of copper is 34°C/W. For tighter layouts, 0.5in² typically exhibits 40°C/W. Adding multiple vias under the MAX1709EUI+ to conduct heat to the bottom of the board will also help dissipate power.

Due to high inductor current levels and fast switching waveforms, proper PC board layout is essential. Protect sensitive analog grounds by using a star ground configuration. Connect PGND, the input bypass capacitor ground lead, and the output filter capacitor ground lead to a single point (star ground configuration). In addition, minimize trace lengths to reduce stray capacitance and trace resistance, especially from the LX pins to the catch diode (D1) and output capacitors (C6 and C7) to PGND pins. If an external resistor-divider is used to set the output voltage (Figure 4), the trace from FB to the resistors must be extremely short and must be shielded from switching signals, such as CLK or LX. Refer to a layout example in the MAX1709EVKIT data sheet.

Chip Information

TRANSISTOR COUNT: 1112

Package Information

For the latest package outline information and land patterns (footprints), go to www.maximintegrated.com/packages. Note that a "+", "#", or "-" in the package code indicates RoHS status only. Package drawings may show a different suffix character, but the drawing pertains to the package regardless of RoHS status.

PACKAGE TYPE	PACKAGE CODE	OUTLINE NO.	LAND PATTERN NO.
16 SOIC (N)	S16+8	21-0041	90-0097
28 TSSOP-EP	U28E+4	21-0108	90-0146

Revision History

REVISION NUMBER	REVISION DATE	DESCRIPTION	PAGES CHANGED
3	2/15	Updated the <i>Benefits and Features</i> section	1

For pricing, delivery, and ordering information, please contact Maxim Direct at 1-888-629-4642, or visit Maxim Integrated's website at www.maximintegrated.com.

Maxim Integrated cannot assume responsibility for use of any circuitry other than circuitry entirely embodied in a Maxim Integrated product. No circuit patent licenses are implied. Maxim Integrated reserves the right to change the circuitry and specifications without notice at any time. The parametric values (min and max limits) shown in the Electrical Characteristics table are guaranteed. Other parametric values quoted in this data sheet are provided for guidance.

Mouser Electronics

Authorized Distributor

Click to View Pricing, Inventory, Delivery & Lifecycle Information:

[Analog Devices Inc.:](#)

[MAX1709ESE+](#) [MAX1709ESE+T](#) [MAX1709EUI+](#) [MAX1709EUI+T](#)