

# Spezifikation für Freigabe / specification for release

Kunde / customer :  
 Artikelnummer / part number : **7498111120R**  
 Bezeichnung : **LAN-Übertrager WE-RJ45LAN 1000Base-T**  
 description : **LAN-Transformer WE-RJ45LAN 1000Base-T**



DATUM / DATE : 2020-08-11

## A Mechanische Abmessungen / dimensions :

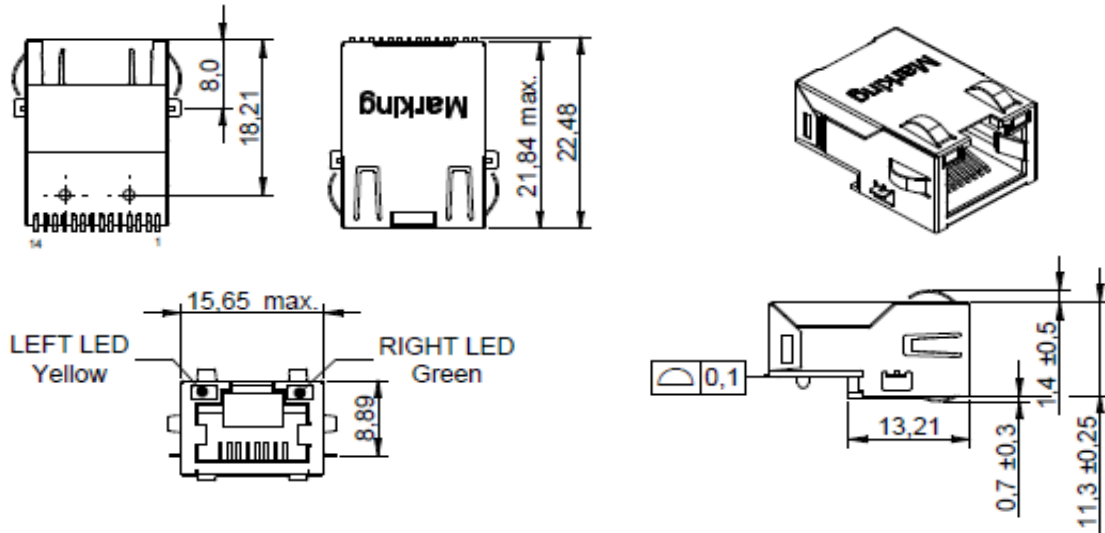

## B Lötpad / soldering spec. :

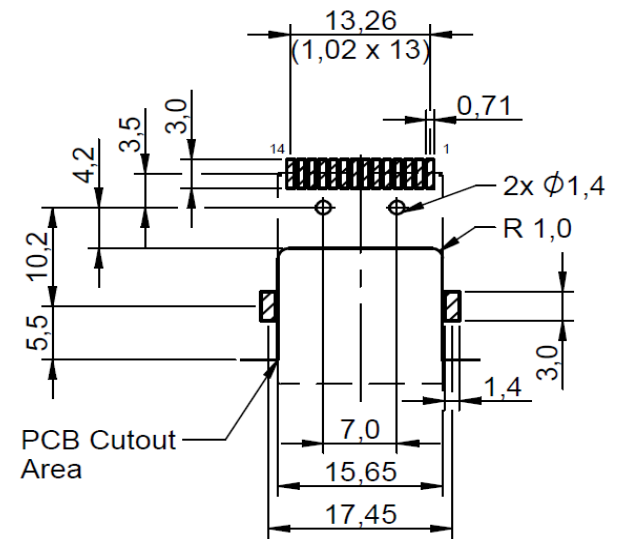

## C Elektrische Eigenschaften / electrical properties :

Eigenschaften / properties	Testbedingungen / test conditions		Wert / value	Einheit / unit	tol.
Induktivität / Inductance	100kHz / 100mV @ 8mA DC-Bias	OCL	350	µH	min.
Übersetzungsverhältnis / Turns ratio	100kHz / 100mV	TR	1 : 1	Tx	2%
			1 : 1	Rx	
Insertion Loss	1-100MHz	IL	-1.0	dB	max.
Return Loss	1-30MHz	RL	-18	dB	min.
	30-60 MHz		-15		
	60-80MHz		-12		
	80-100MHz		-10		
Common Mode Rejection	1-50MHz	CMR	-30	dB	min.
	50-130MHz		-20		
Crosstalk	1-30MHz	CT	-37	dB	min.
	30-60MHz		-32		
	60-100MHz		-27		

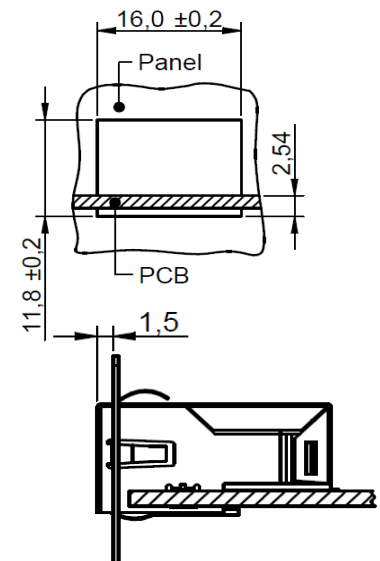

## D Prüfgeräte / test equipment :

Agilent 4395A Network Analyzer

## E Testbedingungen / test conditions :

Luftfeuchtigkeit / humidity: 33%  
 Umgebungstemperatur / temperature: +25°C

## F Werkstoffe & Zulassungen / material & approvals :

Basismaterial / base material: Ferrit/ ferrite  
 Draht / wire: QPN 180  
 Kontaktmaterial/ contact plating: 100% tin w. nickel underplating  
 30µ"gold plating on contact area  
 Gehäuse / housing: Thermoplastic UL 94V-0  
 LED: 1,8-2,5V / 20mA  
 Shield: 50µ" nickel  
 over 0.008" cooper alloy

## G Eigenschaften / general specifications :

Betriebstemp. / operating temperature: 0°C - + 70°C  
 Hochspannungsprüfung / Hipot test: 2250Vdc 1min.  
 Geeignet für 1000Base-TX gemäß IEEE 802.3ab /  
 Compliant with IEEE 802.3ab for 1000Base-TX-Applications  
 Auto MDIX fähig / Auto MDIX capable  
 UL File: E472316

Freigabe erteilt / general release:

**Kunde / customer**

Datum / date

Unterschrift / signature

**Würth Elektronik**

Geprüft / checked

Kontrolliert / approved

JuHa	Revision 04	2020-08-11
Mle	Revision 03	2020-03-20
Mle	Revision 02	2018-08-07
Mle	Revision 01	2017-09-22
MMai	Revision 00	2016-02-24
Name	Änderung / modification	Datum / date

**Würth Elektronik eiSos GmbH & Co.KG**

D-74638 Waldenburg · Max-Eyth-Straße 1 - 3 · Germany · Telefon (+49) (0) 7942 - 945 - 0 · Telefax (+49) (0) 7942 - 945 - 400  
 http://www.we-online.com

# Spezifikation für Freigabe / specification for release

Kunde / customer :  
 Artikelnummer / part number : **7498111120R**  
 Bezeichnung : **LAN-Übertrager WE-RJ45LAN 1000Base-T**  
 description : **LAN-Transformer WE-RJ45LAN 1000Base-T**



DATUM / DATE : 2020-08-11

## H Schaltbild / Schematics :

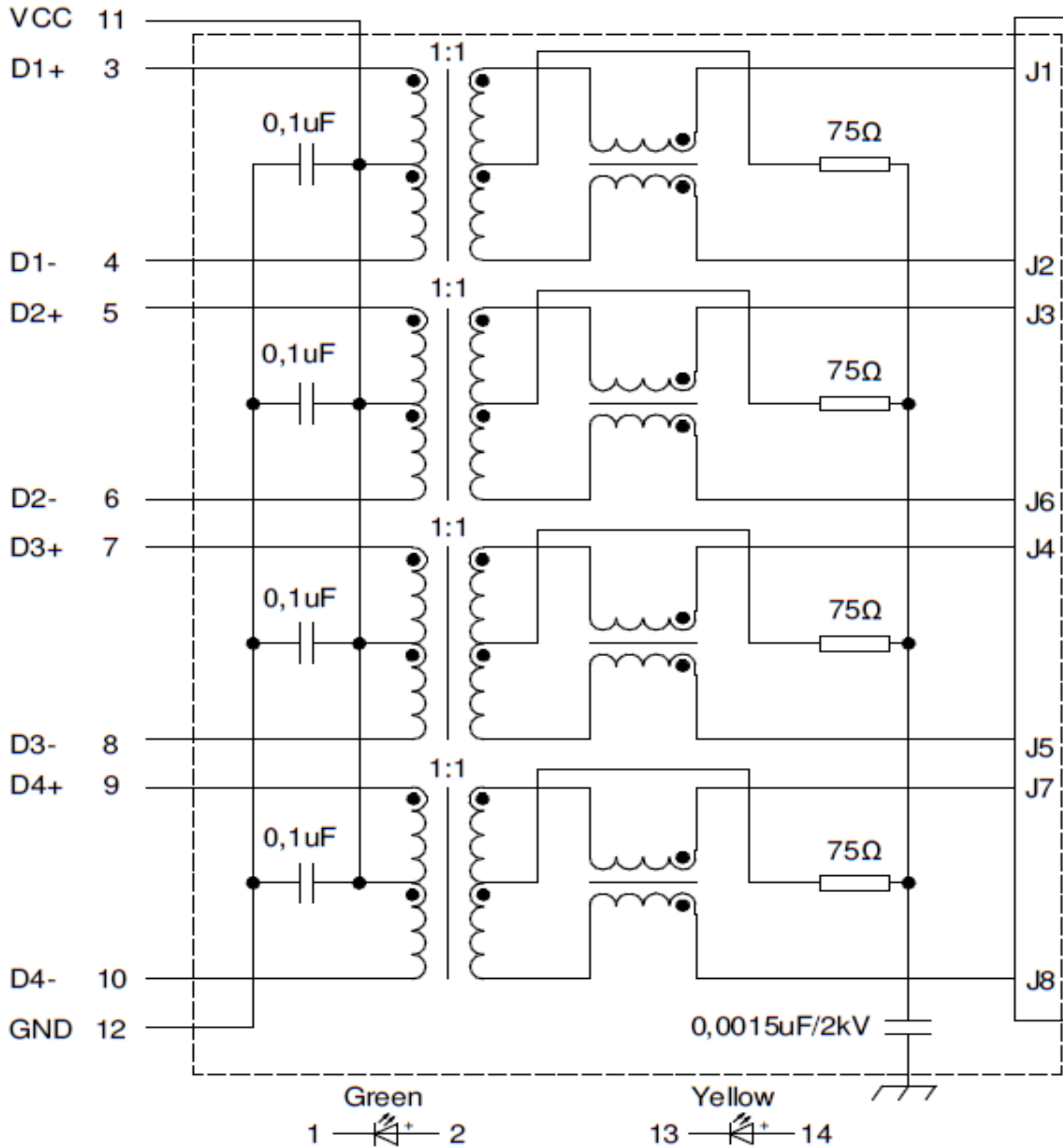

Freigabe erteilt / general release:	<b>Kunde / customer</b>			
.....	.....	JuHa	Revision 04	2020-08-11
Datum / date	Unterschrift / signature	Mle	Revision 03	2020-03-20
.....	<b>Würth Elektronik</b>	Mle	Revision 02	2018-08-07
.....	.....	Mle	Revision 01	2017-09-22
Geprüft / checked	Kontrolliert / approved	MMai	Revision 00	2016-02-24
		Name	Änderung / modification	Datum / date

### Würth Elektronik eiSos GmbH & Co.KG

D-74638 Waldenburg · Max-Eyth-Straße 1 - 3 · Germany · Telefon (+49) (0) 7942 - 945 - 0 · Telefax (+49) (0) 7942 - 945 - 400  
<http://www.we-online.com>

# Spezifikation für Freigabe / specification for release

Kunde / customer :  
 Artikelnummer / part number : **749811120R**  
 Bezeichnung : **LAN-Übertrager WE-RJ45LAN 1000Base-T**  
 description : **LAN-Transformer WE-RJ45LAN 1000Base-T**



DATUM / DATE : 2020-08-11

## I Verpackungsspezifikation / package specification :

### Reel:

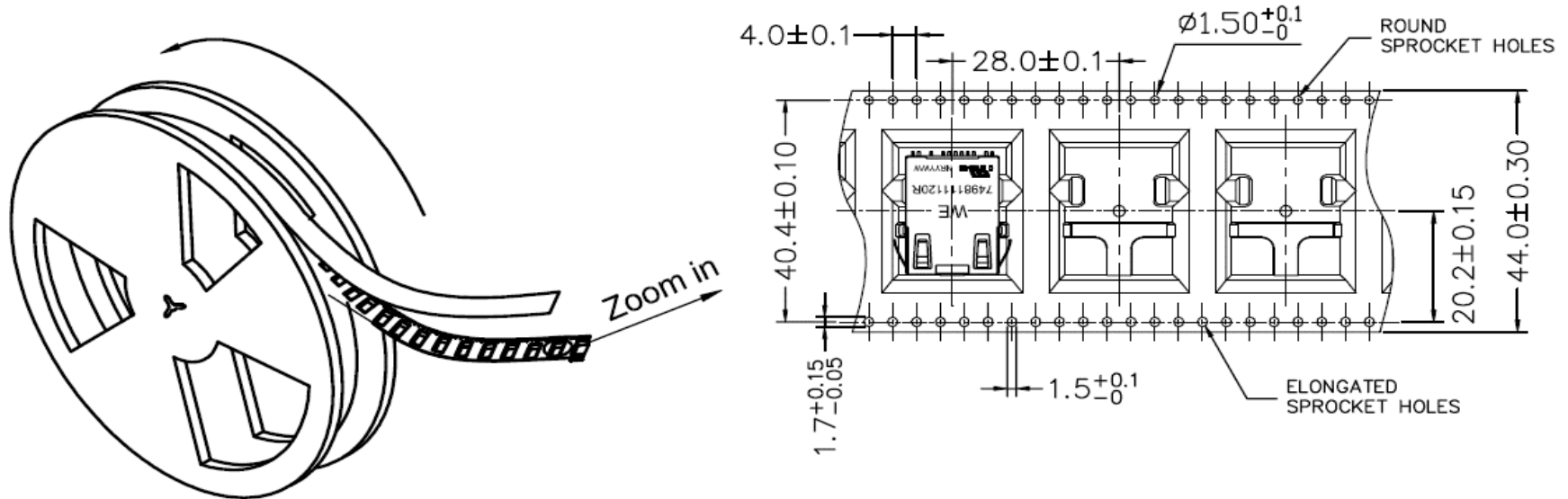

### Carton:

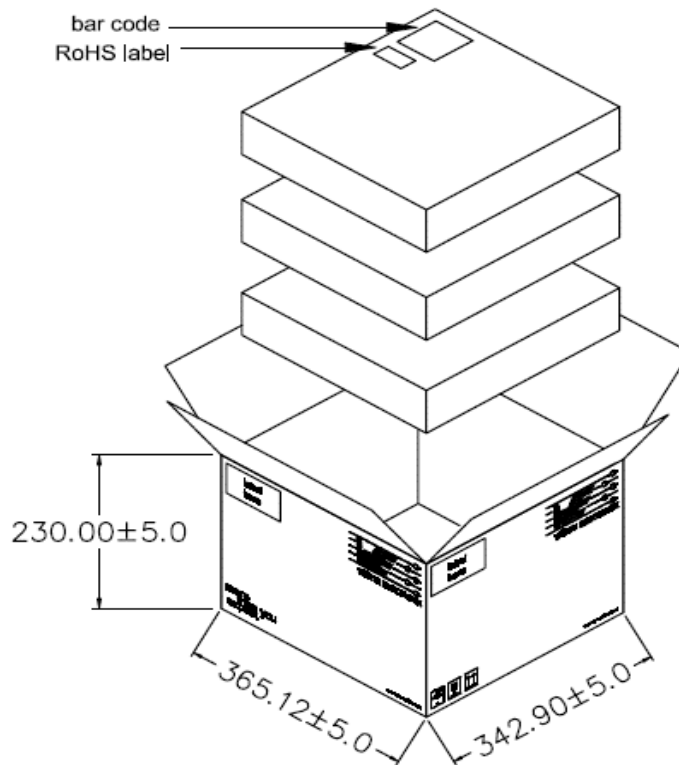

### Packing Quantity:

reel = 100 pcs  
 carton = 300 pcs

dimensions in mm

Freigabe erteilt / general release:	<b>Kunde / customer</b>		
.....	.....	JuHa	Revision 04
Datum / date	Unterschrift / signature	Mle	Revision 03
	<b>Würth Elektronik</b>	Mle	Revision 02
.....	.....	Mle	Revision 01
Geprüft / checked	Kontrolliert / approved	MMai	Revision 00
		Name	Änderung / modification
			Datum / date

This electronic component has been designed and developed for usage in general electronic equipment. Before incorporating this component into any equipment where higher safety and reliability is especially required or if there is the possibility of direct damage or injury to human body, for example in the range of aerospace, aviation, nuclear control, submarine, transportation, (automotive control, train control, ship control), transportation signal, disaster prevention, medical, public information network etc, Würth Elektronik eiSos GmbH must be informed before the design-in stage. In addition, sufficient reliability evaluation checks for safety must be performed on every electronic component which is used in electrical circuits that require high safety and reliability functions or performance.

## Würth Elektronik eiSos GmbH & Co.KG

D-74638 Waldenburg · Max-Eyth-Straße 1 - 3 · Germany · Telefon (+49) (0) 7942 - 945 - 0 · Telefax (+49) (0) 7942 - 945 - 400  
<http://www.we-online.com>

# Mouser Electronics

Authorized Distributor

Click to View Pricing, Inventory, Delivery & Lifecycle Information:

[Wurth Elektronik:](#)

[7498111120R](#)