

LOC		DIST		REVISIONS			
P	LTN	DESCRIPTION	DATE	DWN	APVD		
A		INITIAL RELEASE	21MAY2014	CW	SH		
A1		ECR-14-015540	10OCT2014	CW	SH		
A2		ECR-14-018430		CW	SH		
A3		REVISED PER ECO-17-014881	11OCT2017	IT	SH		

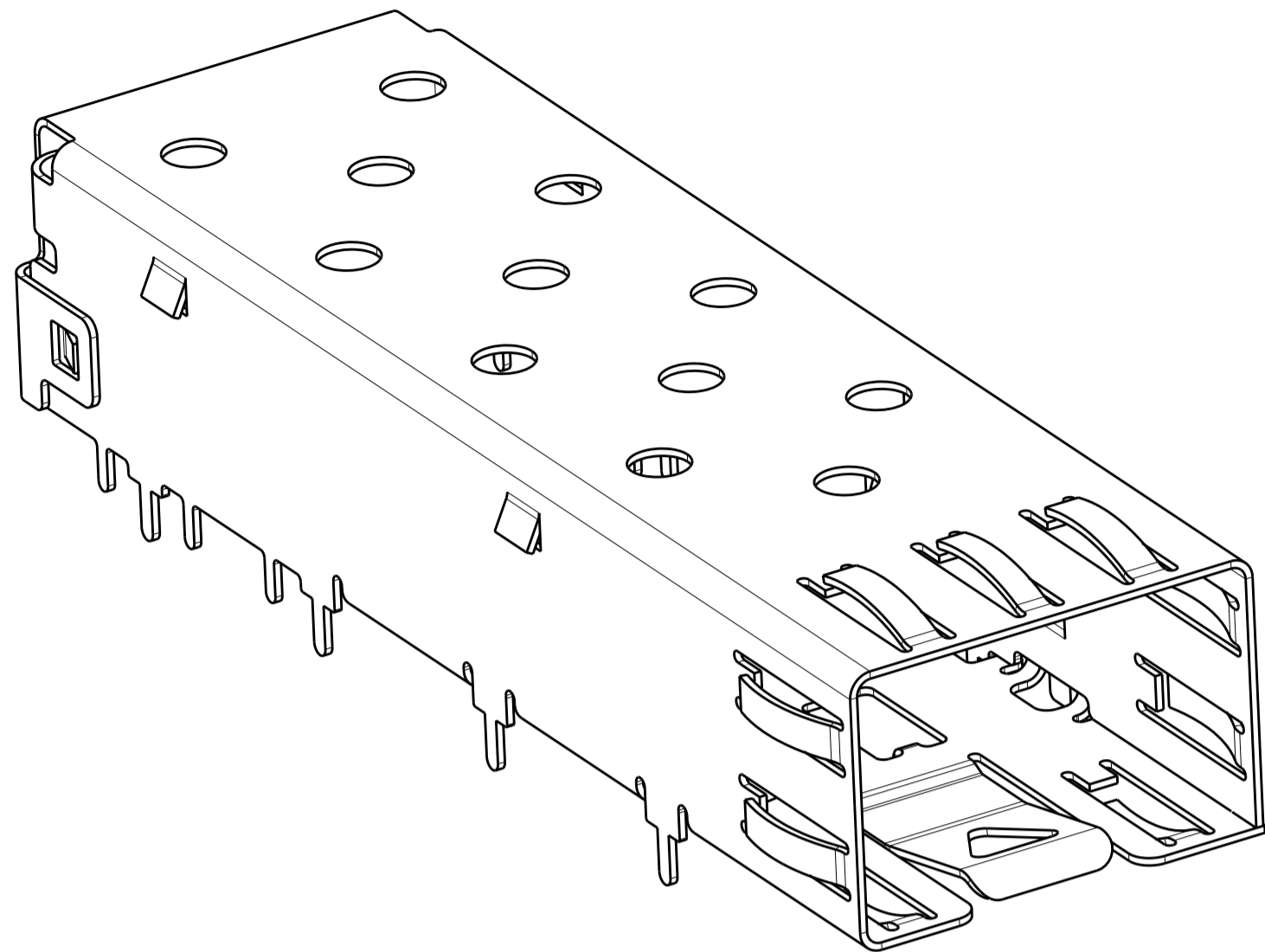

2227303-1, -2, -3, -7
 1-2227303-2

- △ MATERIAL: 0.25mm THICK STAINLESS STEEL.
- △ FINISH: 0.00125mm Min. NICKEL OVER ALL , 0.002mm Min. TIN DIPPED ON SOLDER TABS, NON PLATED EDGES PERMISSIBLE.
- 3. MATES WITH SFP MSA COMPLIANT TRANSCEIVERS.
- △ PADS AND VIAS CHASSIS GROUND.
- △ DATUM AND BASIC DIMENSION ESTABLISHED BY CUSTOMER.
- 6. MINIMUM PC BOARD THICKNESS:
 SINGLE SIDED = 1.50 mm
- △ REFERENCE APPLICATION SPEC. 114-13120, HOLE A, FOR RECOMMENDED DRILL HOLE DIAMETER AND PLATING THICKNESS.
- △ REFERENCE APPLICATION SPEC. 114-13120, HOLE C, FOR RECOMMENDED DRILL HOLE DIAMETER AND PLATING THICKNESS.
- △ ESD PROTECTION PACKAGE.
- △ PRELIMINARY PART- NOT RELEASED FOR PRODUCTION
- △ WITHOUT EMI SPRING

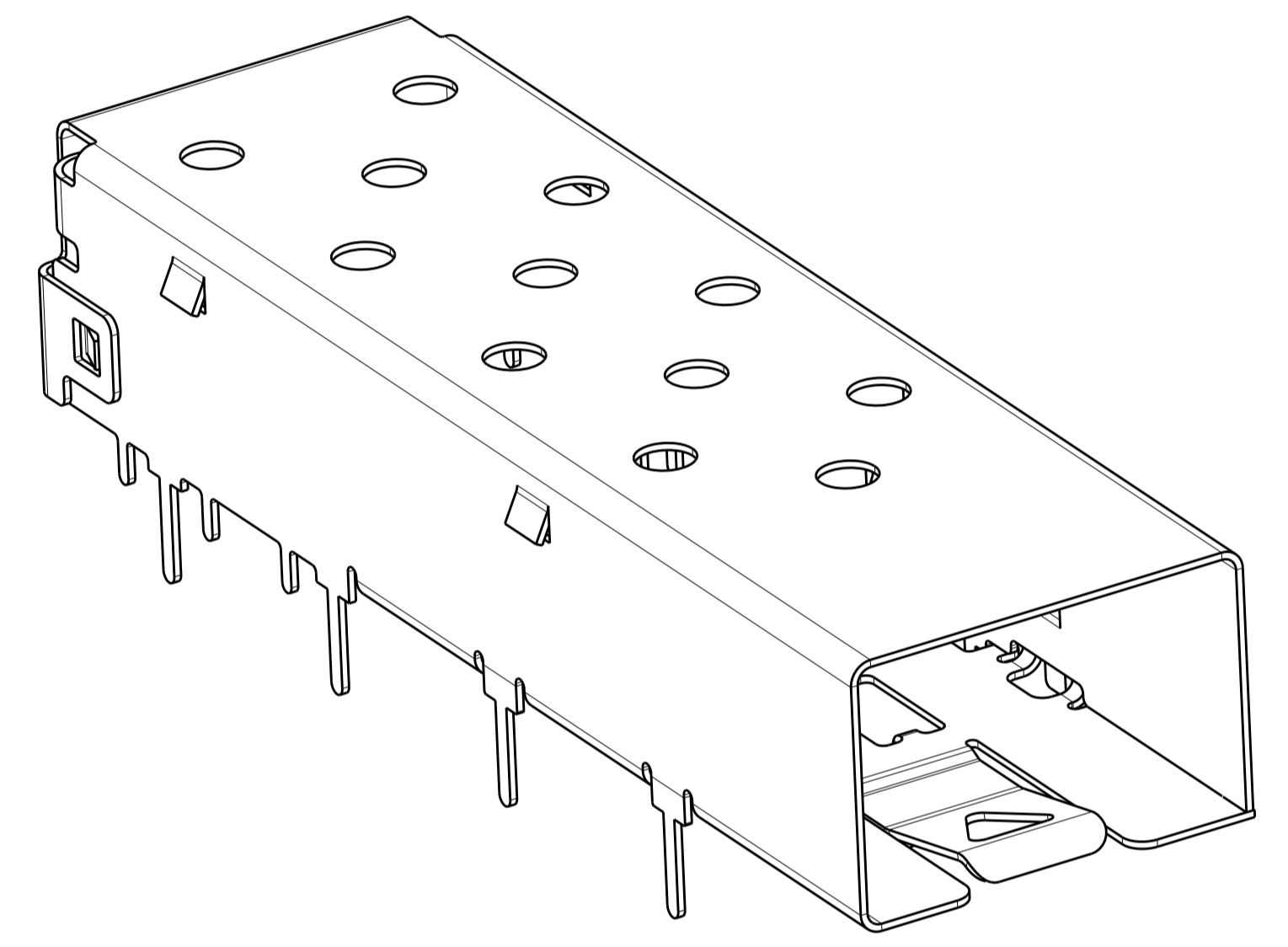
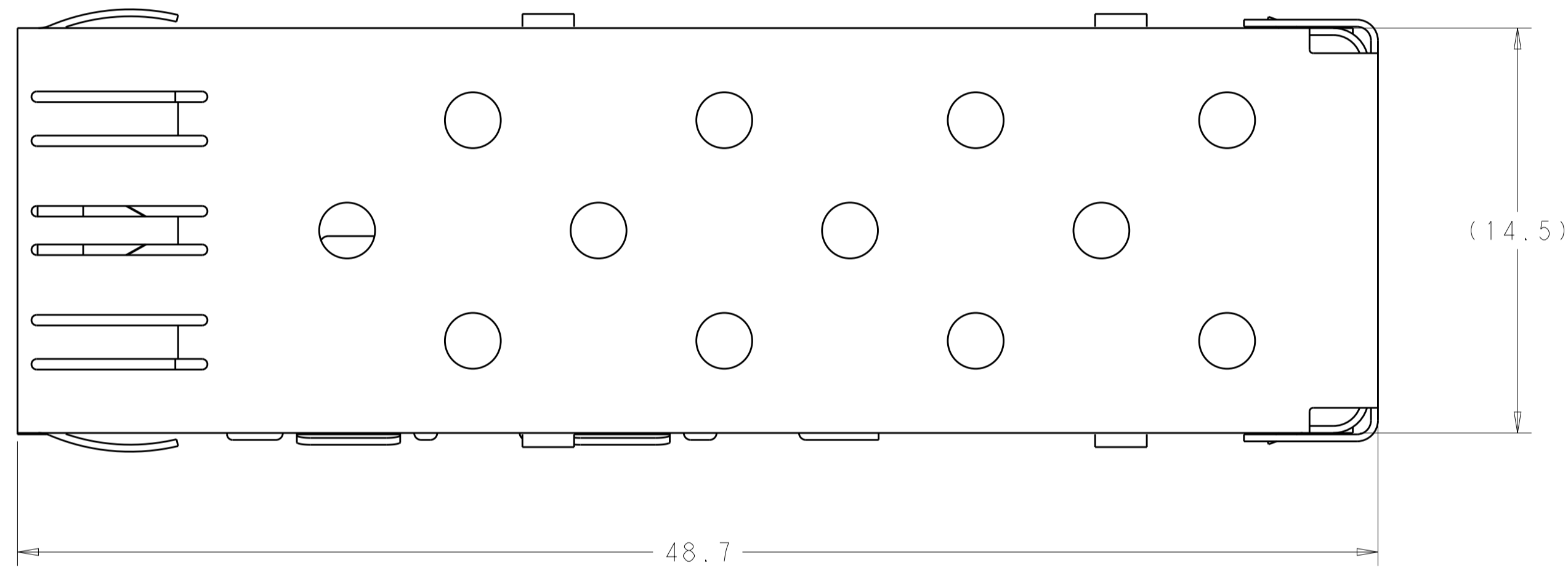

△ 1-2227303-1

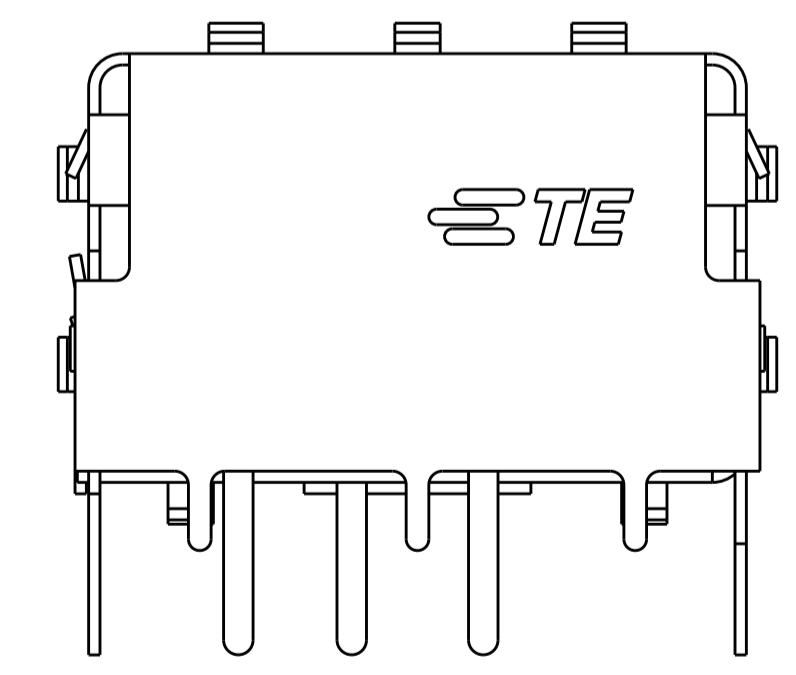
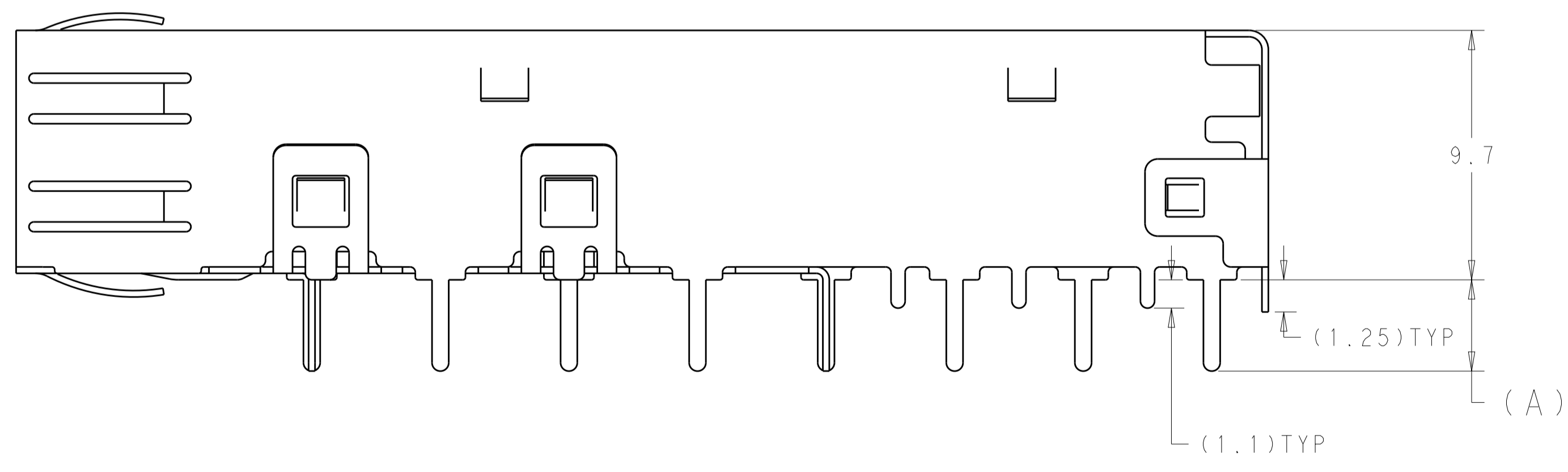
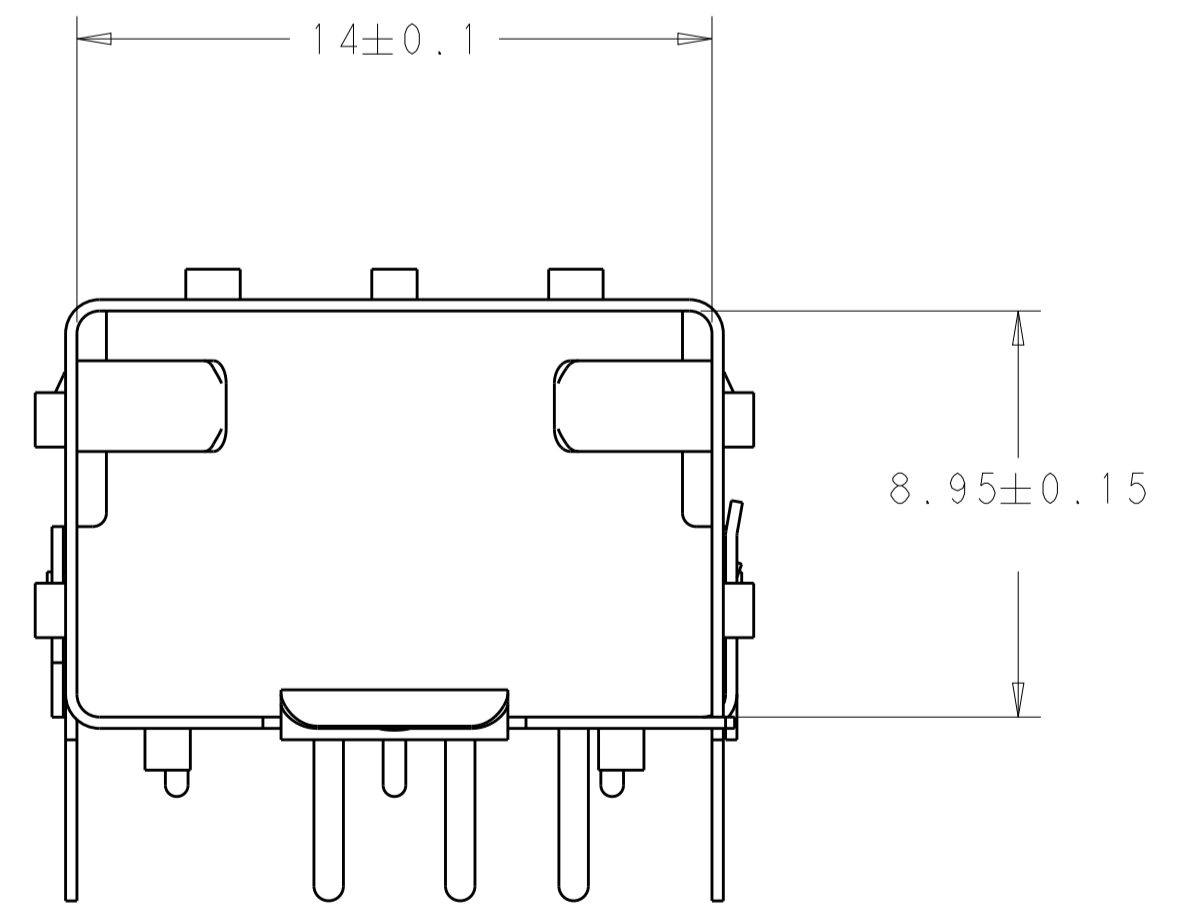

△ TRAY	3.55	1-2227303-1
△ TRAY	3.55	2227303-7
△ REEL	1.80	1-2227303-2
TRAY	1.80	2227303-3
REEL	1.80	2227303-2
TRAY	3.55	2227303-1
PACKAGING	A	PART NUMBER

THIS DRAWING IS A CONTROLLED DOCUMENT. DIMENSIONING AND TOLERANCING PER ASME Y14.5M-2009.		DWN C. VALENTINE 19OCT2012	TE Connectivity NAME SFP, 1X1 SINGLE PIECE CAGE, SOLDER PIN	
DIMENSIONS: mm		CHK M. SCHMITT 19OCT2012		
TOLERANCES UNLESS OTHERWISE SPECIFIED:		APVD M. SCHMITT 19OCT2012	SIZE CAGE CODE DRAWING NO RESTRICTED TO	
0 PLC	±0.1	PRODUCT SPEC	A100779C=2227303	
1 PLC	±0.1	108-1950	SCALE 6:1 SHEET 1 OF 3 REV A3	
2 PLC	±0.1	APPLICATION SPEC	Customer Drawing	
3 PLC	±0.1	114-13120		
4 PLC	±0.1	WEIGHT		
ANGLES	±°			
MATERIAL				
FINISH				

LOC	DIST	REV	DATE	BY	APPV
GP	00				

REVISIONS			
NO.	DESCRIPTION	DATE	BY
1	SEE SHEET 1		

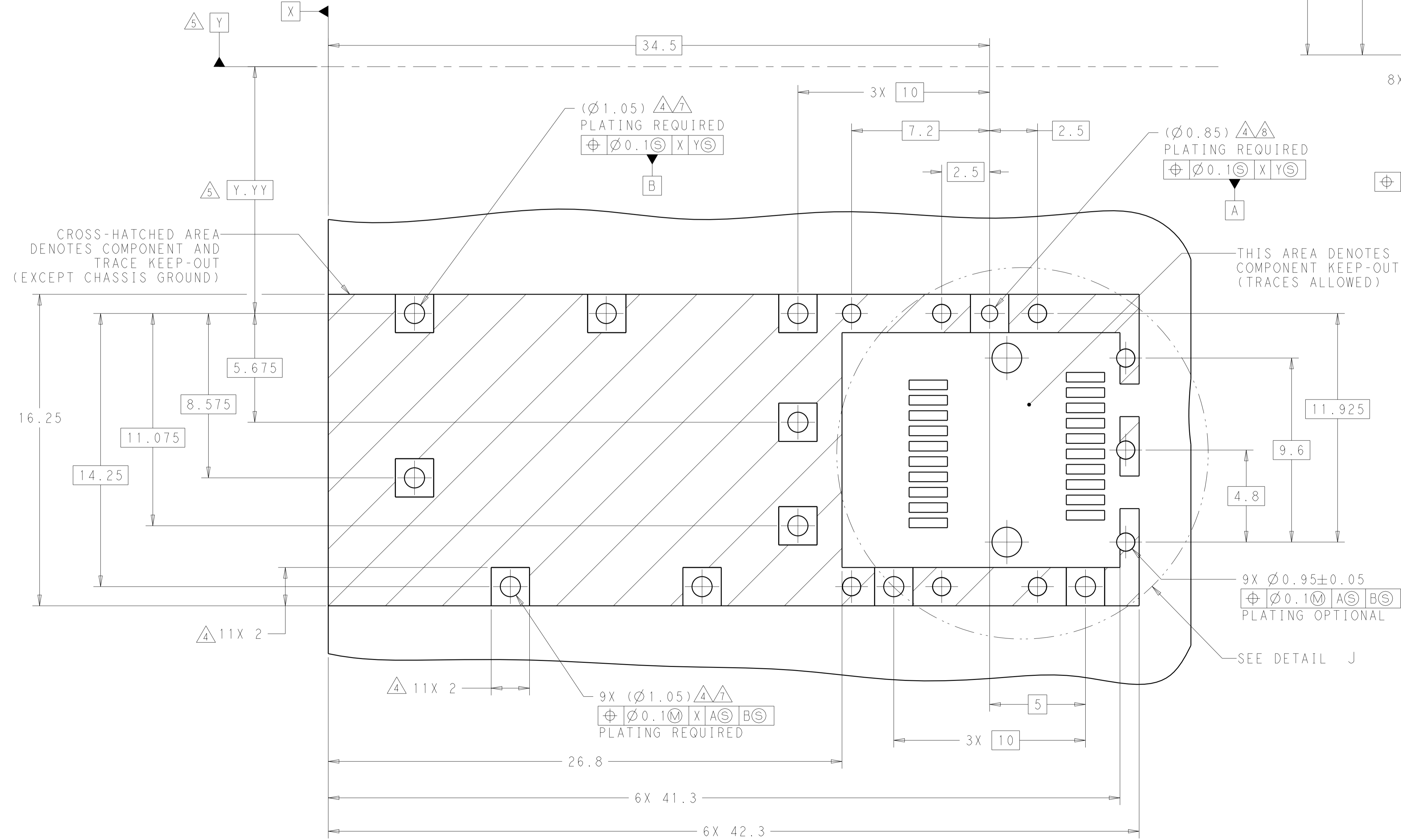
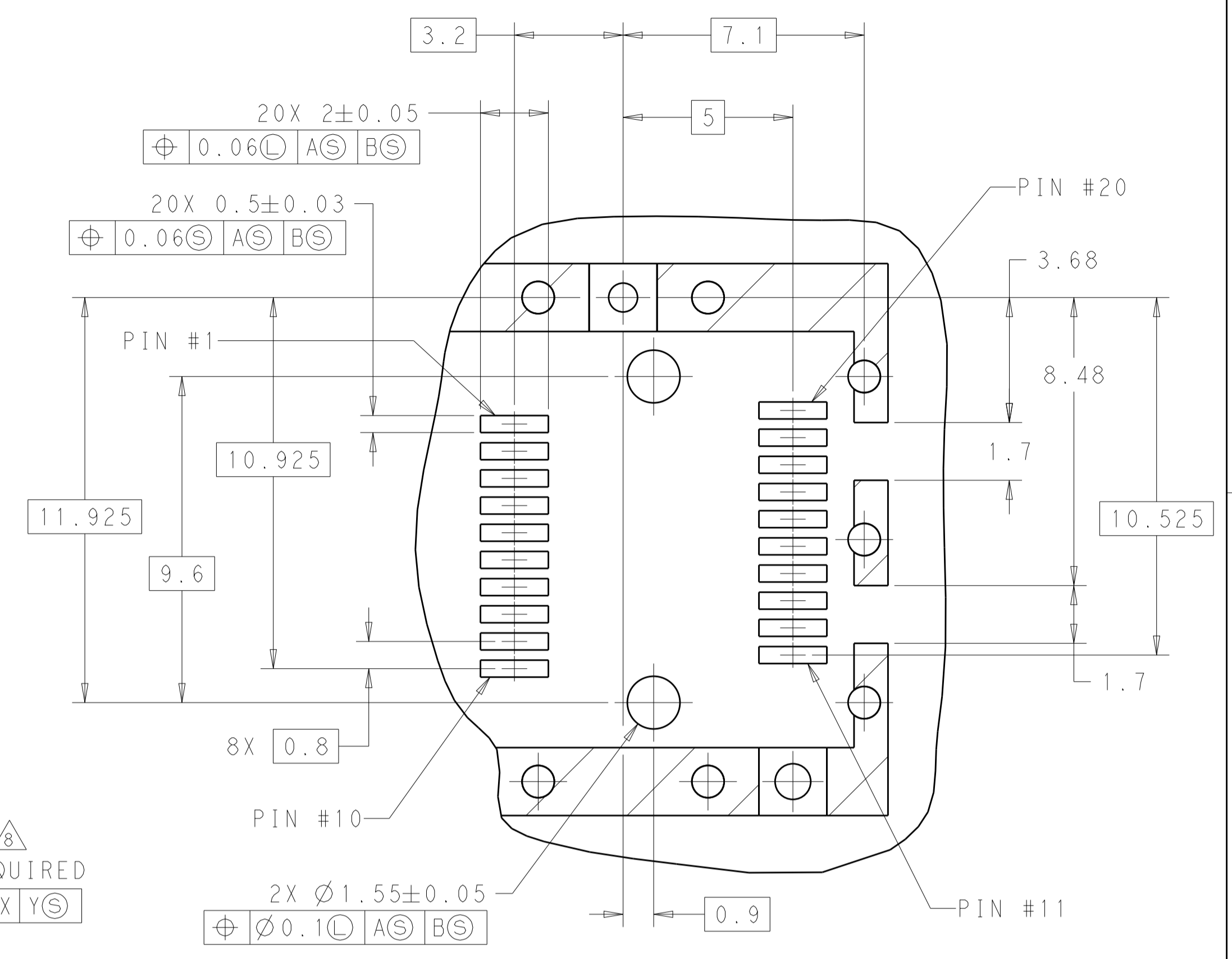
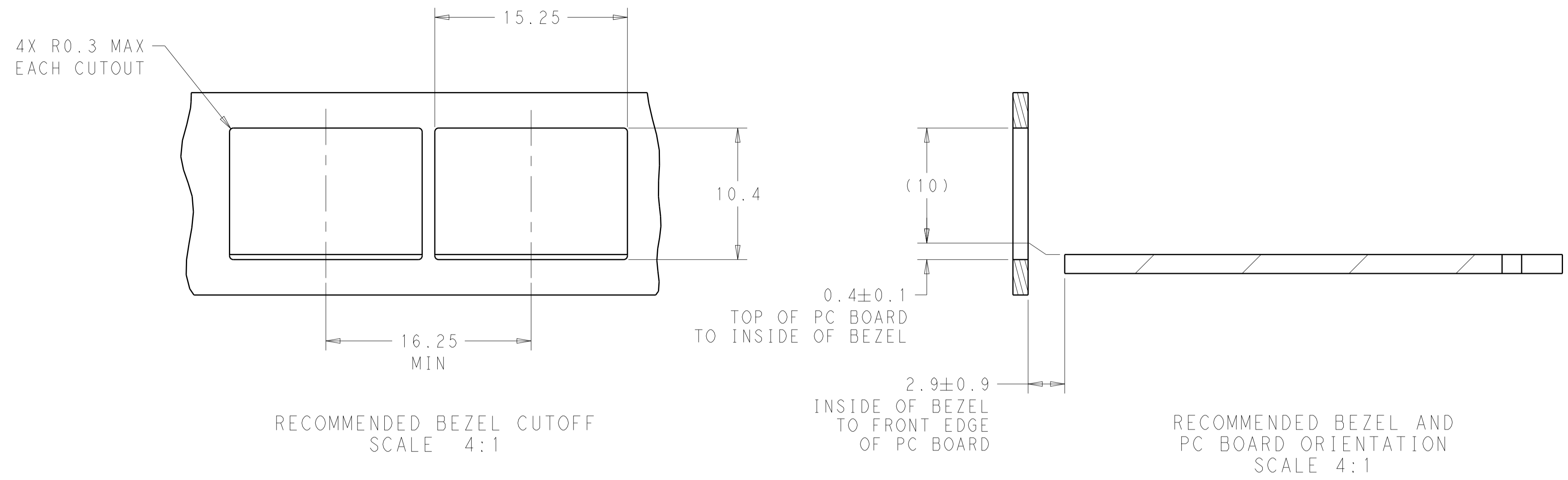

RECOMMENDED PCB LAYOUT SCALE 8:1

THIS DRAWING IS A CONTROLLED DOCUMENT. DIMENSIONING AND TOLERANCING PER ASME Y14.5M-2009.		DWN: C. VALENTINE 19OCT2012 CHK: M. SCHMITT 19OCT2012 APVD: M. SCHMITT 19OCT2012	TE Connectivity
DIMENSIONS: mm TOLERANCES UNLESS OTHERWISE SPECIFIED: 0 PLC ±0.1 1 PLC ±0.1 2 PLC ±0.1 3 PLC ±0.1 4 PLC ±0.1 ANGLES °		NAME: SFP, 1X1 SINGLE PIECE CAGE, SOLDER PIN PRODUCT SPEC: 108-1950 APPLICATION SPEC: 114-13120 WEIGHT: - Customer Drawing	
MATERIAL: -		SIZE: A1 CAGE CODE: 00779 DRAWING NO: C=2227303	RESTRICTED TO: - SCALE: 6:1 SHEET: 2 OF 3 REV: A3

LOC		DIST		REVISIONS			
GP	00	P	LTN	DESCRIPTION	DATE	DWN	APVD
		-		SEE SHEET 1			

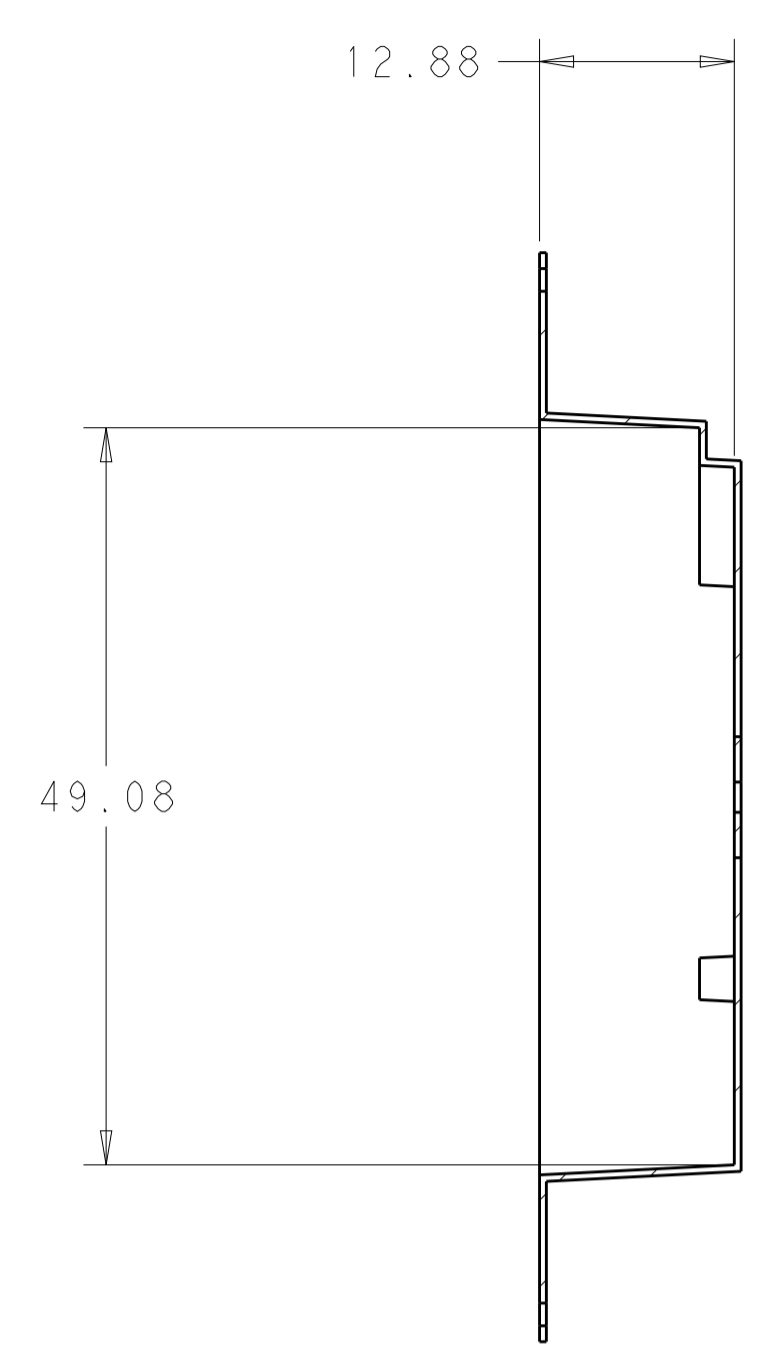
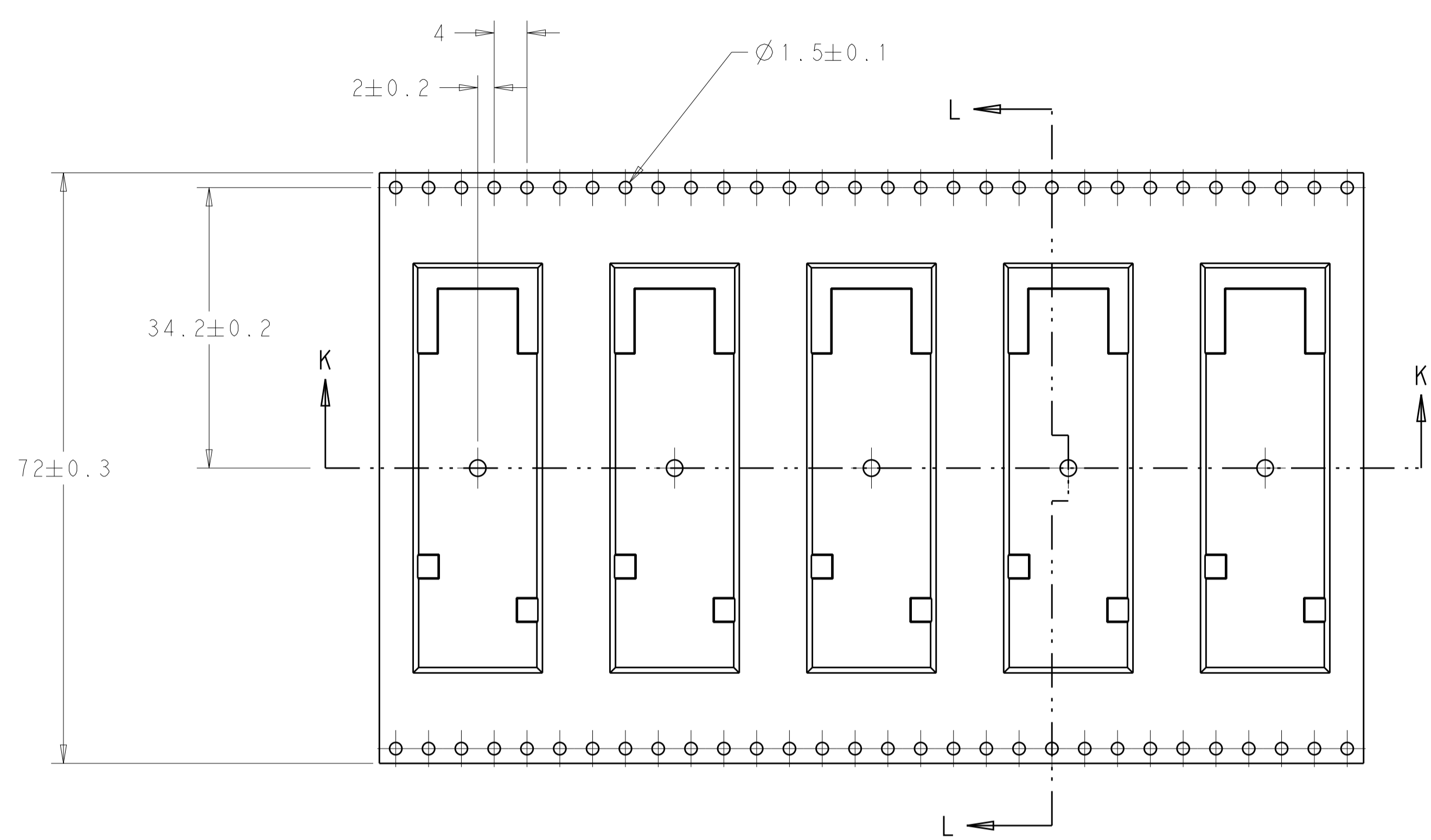

SECTION L-L

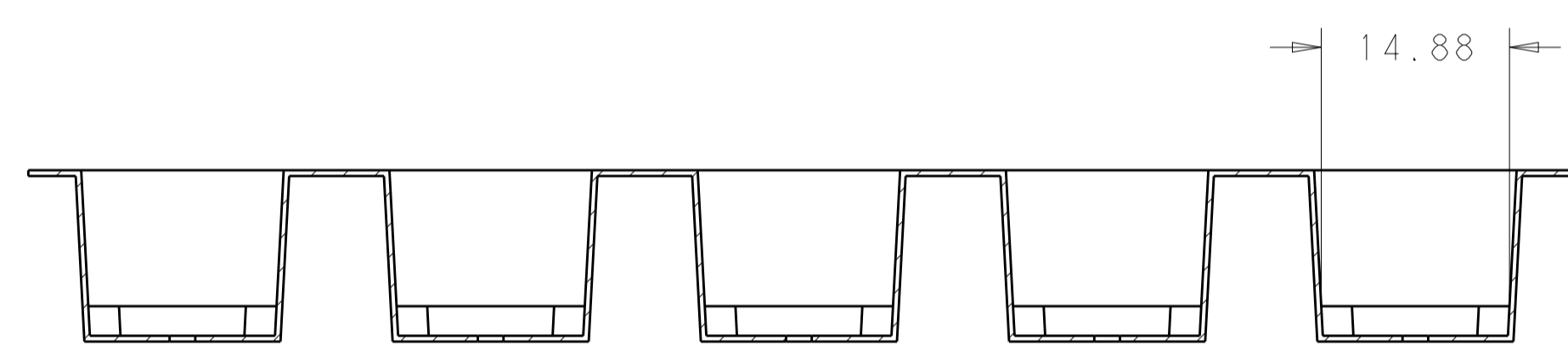

SECTION K-K
SCALE 2:1

2227303-2 / 1-222303-2 REEL PACKAGING

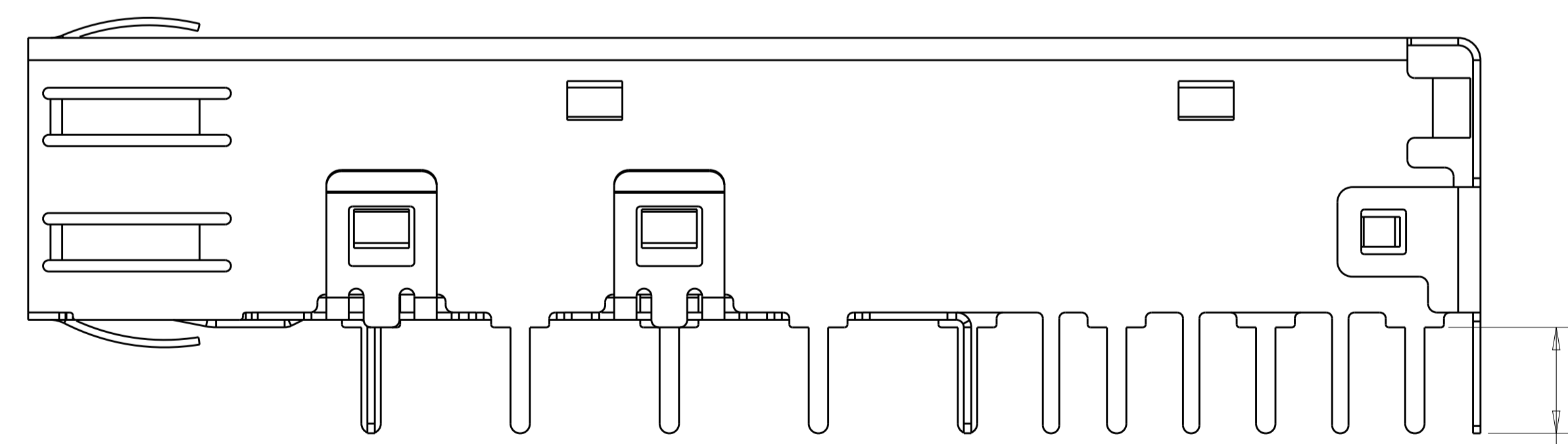
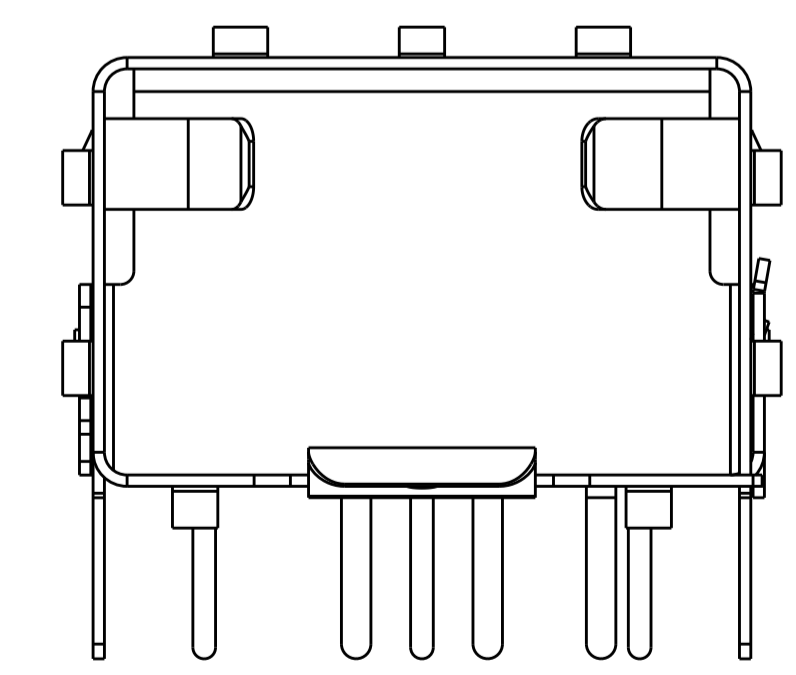

(A)
APPLIED ALL PINS

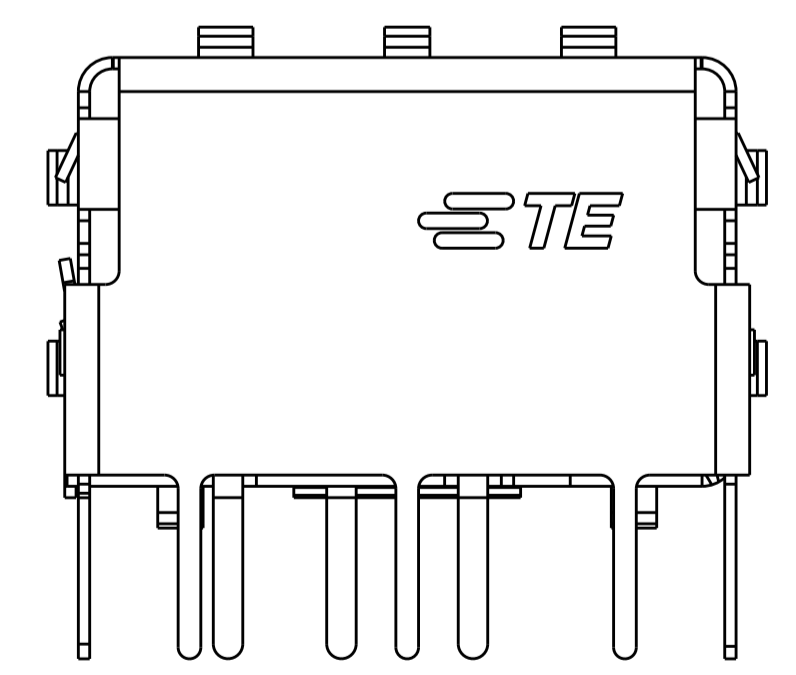

2227303-7
UNMARKED DIMENSIONS SAME AS 2227303-1
SCALE 6:1

THIS DRAWING IS A CONTROLLED DOCUMENT. DIMENSIONING AND TOLERANCING PER ASME Y14.5M-2009		DWN C. VALENTINE 19OCT2012	TE Connectivity	
DIMENSIONS: mm		CHK M. SCHMITT 19OCT2012		
TOLERANCES UNLESS OTHERWISE SPECIFIED:		APVD M. SCHMITT 19OCT2012	NAME SFP, 1X1 SINGLE PIECE CAGE, SOLDER PIN	
0 PLC ±0.1	1 PLC ±0.1	PRODUCT SPEC 108-1950	SIZE CAGE CODE DRAWING NO RESTRICTED TO	
2 PLC ±0.1	3 PLC ±0.1	APPLICATION SPEC 114-13120	A100779C=2227303	
4 PLC ±0.1	ANGLES ±°	WEIGHT	SCALE 6:1 SHEET 3 OF 3 REV A3	
MATERIAL	FINISH	Customer Drawing		